

(No Model.)

2 Sheets—Sheet 1.

C. F. HANINGTON.  
DOOR CHECK.

No. 601,830.

Patented Apr. 5, 1898.

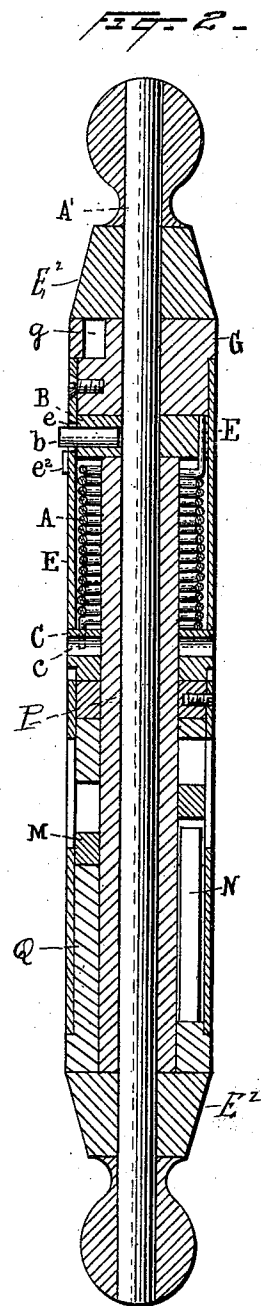
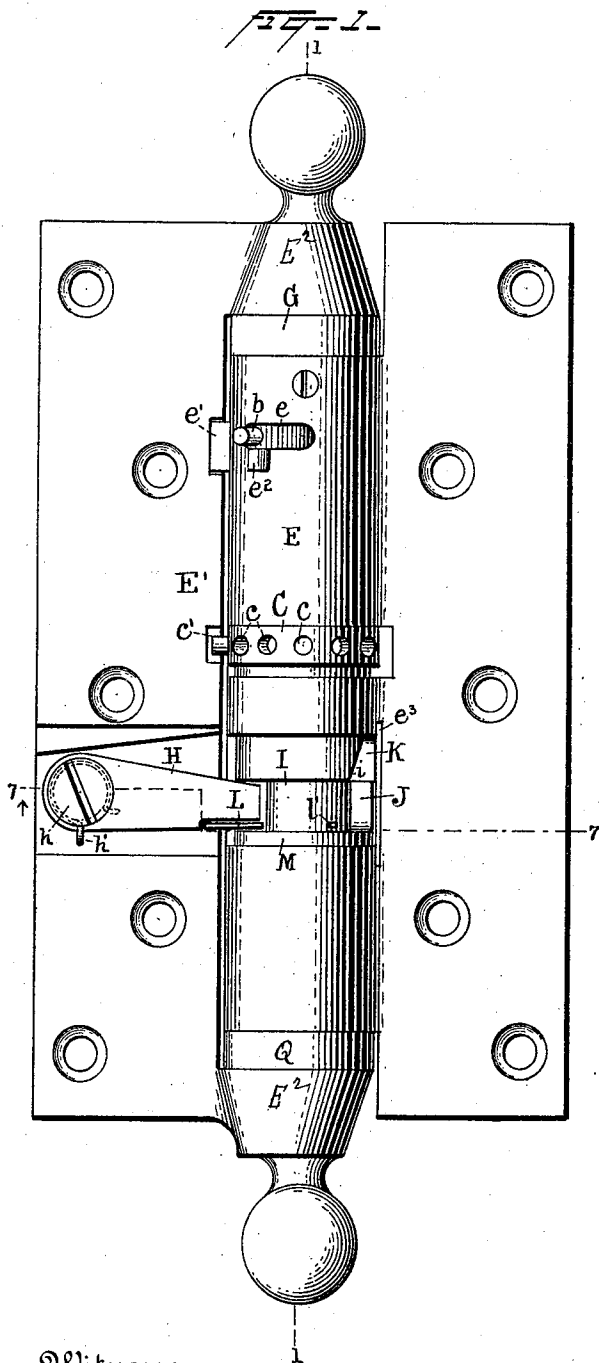

Witnesses  
*Norris A. Clark.*  
*Jno. R. Taylor.*

Inventor  
*Charles F. Hanington*  
 By his Attorneys *Allyn & Dwyer*

C. F. HANINGTON.  
DOOR CHECK.

No. 601,830.

Patented Apr. 5, 1898.

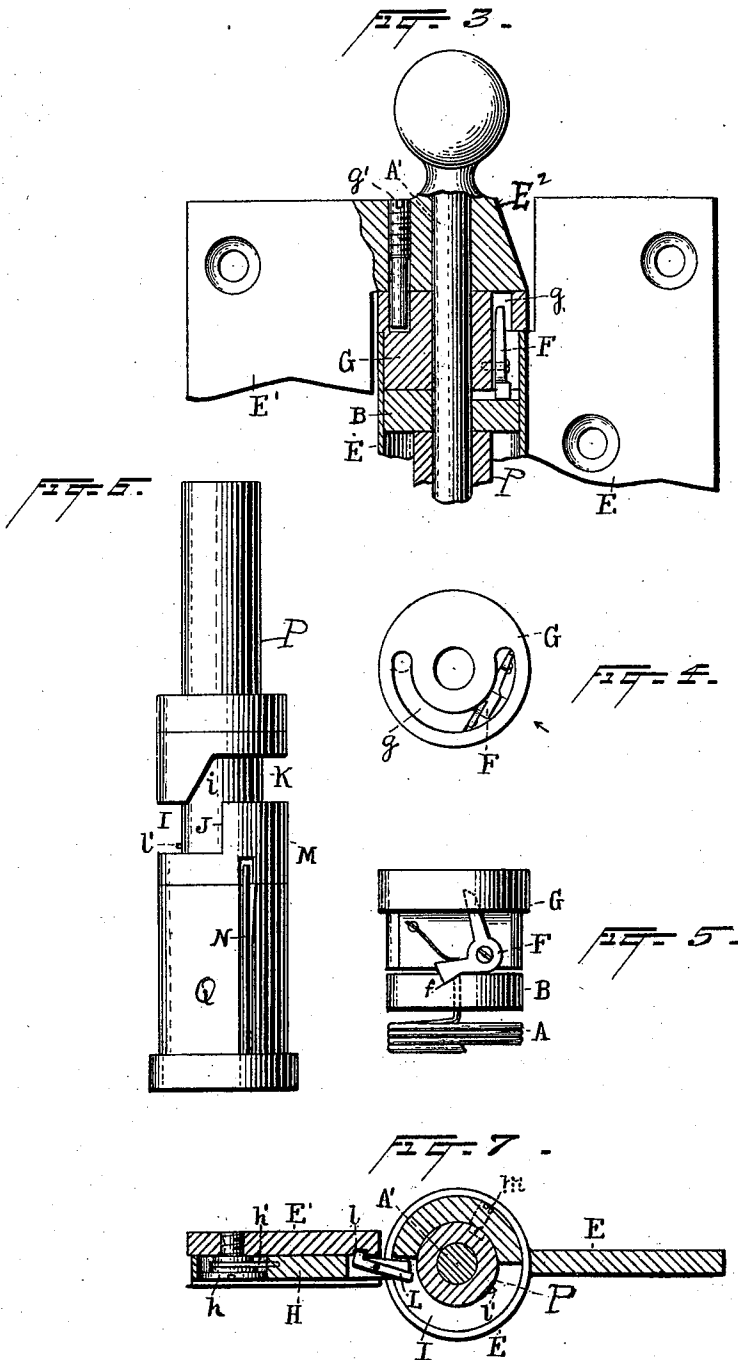

Witnesses  
 Morris A. Clark.  
 Jas. R. Taylor.

Inventor  
 Charles F. Hanington  
 By his Attorneys  
 Allen & Driscoll

# UNITED STATES PATENT OFFICE.

CHARLES F. HANINGTON, OF NEW YORK, N. Y., ASSIGNOR TO THE  
MECHANICAL DOOR HINGE CHECK COMPANY, OF NEW YORK.

## DOOR-CHECK.

SPECIFICATION forming part of Letters Patent No. 601,830, dated April 5, 1898.

Application filed November 3, 1896. Serial No. 610,995. (No model.)

*To all whom it may concern:*

Be it known that I, CHARLES F. HANINGTON, a citizen of the United States, residing at New York city, in the county and State of New York, have invented a certain new and useful Improvement in Door-Checks, of which the following is a specification.

My invention relates to an improvement in door-checks. Great difficulty has been found in the construction of an effective door-check because of the exceptional conditions which it must fulfil. A spring must be connected with the door which will be of sufficient strength to close it under any conditions of draft and from any position. This means that the spring must have considerably more than sufficient power to close the door from a wide-open position. The office of a door-check is to permit such a spring to act upon a door without allowing the door to slam, and to do this effectually some force working against the actuating-spring of the door must be interposed before the door is fully closed to stop it. When this is done, the interposed force must be removed, so that the actuating-spring may close and latch the door quietly.

Many devices have been invented to act as door-checks, but so far as I am aware none have combined what I consider the two requisites of a successful door-check. These requisites are, first, a device which will never fail under any circumstances to check the door and then allow it to close. This, I believe, can only be accomplished by making the check operate by the positive movement of solid interconnected parts upon each other. Second, such a check should operate on the door from a concealed position, for a door-check while efficiently performing its function must not be seen and so detract from the appearance of the door.

All the mechanical door-checks with which I am acquainted are more or less unsightly, being usually attached to the framework of the door, and all the concealed checks known to me are not mechanical, but employ some fluid—either air, oil, glycerin, or like substance—in a dash-pot arrangement to lessen the momentum of the closing door. Even with expensive workmanship to fit the parts of checks of the latter class experience has

proved that where liquids are used it is impossible to make an absolutely tight door-check, so that if the liquid does not cause annoyance by its leakage at best it must be occasionally replenished, and thus cause variable operation on the part of the door-check. This variability is increased by the fact that differences in temperature are apt to affect the state of the liquid, making it either too viscous or too thin.

In the accompanying description and illustration, in which like letters indicate similar parts, the construction and operation is set forth of a door-check which, while being made up entirely of interacting solid parts, is concealable within the ordinary door-hinge. Continued experiments and trials have proved that by means of the device described hereinafter it is possible to get rid of the unsightly mechanical constructions used heretofore and still construct a device which will invariably check the door.

Figure 1 shows a side view of the hinge containing the checking device and retarding device for the door, with the band covering the check-pawl and related parts removed. Fig. 2 shows a section drawn through the hinge on the line 1 1, Fig. 1. Figs. 3, 4, and 5 show detail drawings of the connections and means for operating and releasing the counter-spring. Fig. 6 shows a detail of the checking device. Fig. 7 is a section (indicated by arrow) cut through Fig. 1 on the line 7 7.

The door-check when in position appears and acts as one of the hinges of the door. The other hinge preferably conceals a spring which serves to close the door, though such spring may be any one of the well-known forms of door-springs.

My door-check operates to bring the door to a full stop during its closing movement and after this is done to allow it to be finally closed by the closing-spring. To do this two substantially rigid parts are brought into contact as the door closes, thus bringing it to a standstill. The door rebounds slightly when one of the rigid parts is moved out of the line of contact with the other. The door may then be closed without further opposition. One of the leaves of the hinge, preferably the moving leaf E', carries countersunk in its face

the spring check-pawl H, held to the leaf E' by the screw *h*, so that the extremity of the pawl extends beyond the inner edge of the leaf and into the shell carried by the leaf E and covering the body of the hinge between the knuckles E<sup>2</sup> of the leaf E'. The ordinary pintle A', which holds the leaves together, has sleeved upon it the tubular pintle P, (see Figs. 2 and 6,) which has integral therewith or sleeved upon it the block P' and the block M, the latter being preferably loosely sleeved upon the tubular pintle. When in position, as shown in Fig. 6, a channel I *i* K is formed between the two blocks. This channel I has the offset or angle *i*, which connects the channel I with the channel or chamber K, situated above the shoulder J, formed by the block M. In these channels the spring check-pawl moves, the spring *h'* giving it a tendency to avoid the shoulder J and move up through the angle *i* of the channel into the chamber K. To prevent this before the proper time, the catch-lever L is pivoted to the check-pawl. (See Figs. 1 and 7.) One end of the catch-lever is adapted to catch in a notch *l* in the leaf E', while the outer end projects slightly beyond the forward face of the check-pawl as it travels toward the shoulder J. The catch-lever holds the check-pawl against its spring until the shoulder J has forced the end of the lever projecting into the channel I flush with the face of the check and released its other end from its notch *l*. On the movement of the check-pawl away from the shoulder J the projecting end of the catch-lever is caught by a lug *l'*, which in passing under the end of the catch-lever throws it into the notch *l* again. The lug *l'*, Fig. 6, which is preferably of tool-steel, passes under the catch-lever without moving it during the movement of the pawl toward the shoulder J.

The block M, loosely sleeved upon the tubular pintle P, rests upon the block Q, which is formed integral with said pintle P or rigidly attached thereto. Set into the block Q are plate-springs N, one or more in number, which are shown as extending above the upper face of the block Q and registering in slots made in the lower part of the block M. These springs are of spring-steel and given a small play of movement, so that the block M may turn slightly upon the tubular pintle, and thus have a slight yielding movement under the blow of the check-pawl, as described later. If it is necessary to limit the movement of block M in order to save the springs, one or more set screws or pins *m*, Fig. 7, may be passed through M to move in short slots in the tubular pintle P. When the screws or pins *m* are forced to the end of the slots, the block M cannot be moved farther.

To conceal the check-pawl and related parts, a thin metal sleeve with a flap secured on the leaf E' over the check-pawl should be provided. This sleeve is not illustrated, as it merely serves as a shell to cover the parts. It passes through the slot *e*<sup>3</sup>, Fig. 1, made in

the leaf E of the hinge, and turns with the leaf E'. Thus the checking device is entirely concealed, while still being easily accessible for the purposes of examination and repair without taking the whole hinge apart.

My door-check may be more readily understood by explaining its operation. If, when the door be closed, the parts are in position so that the end of the check-pawl will lie in the part K of the channel and the door be opened, it will be seen that the end of the check-pawl will travel back from the cavity K and follow down the angle *i* into the channel I. The lug *l'* will pass under the catch-lever L, throwing it into the notch *l* and holding the spring-pawl H in position to impinge upon the shoulder J on its return. In closing the door, instead of returning along the angle *i* of the channel, the check-pawl caught by catch-lever L remains in the same position as when in the channel I and strikes against the shoulder J. The parts are so arranged that this shall occur just before the door is closed, there preferably being enough "give" to the block M, in the case of a very hard impact between the pawl and the shoulder, to allow the door to close without breaking the plate-springs N. As the pawl strikes the shoulder J the free end of the catch-lever L, extending beyond the contact-face of the check-pawl, is pressed down till the catch-lever is thrown out of engagement with its notch *l*. Before the check-pawl can move up along the angle *i* of the channel it strikes the shoulder J of the block M, and the springs N, giving way under the blow, allow the block M to be carried back a certain distance, rapidly slowing down the door and finally bringing it to a full stop. When the door rebounds, and the rebound need be only just sufficient to release the pressure of the pawl upon the shoulder J, the check-pawl flies up into the cavity K, when the door is closed without further opposition by the actuating-spring.

The parts hereinbefore described constitute the elements which are essential to my door-check and which I design using in ordinary cases. For the sake of completeness, however, there is shown in the drawings a retarding device for use in connection with very heavy doors, where such retarding device weakens the strength of the action of the closing-spring as the door is swung to and prevents the door from getting sufficient momentum to endanger the safety of the parts of the check. This device does not operate to stop the door, but when the door is open and the closing-spring is in its most powerful position merely opposes the heavy spring, which is necessary to close and latch the door after it is positively checked by the check-pawl described above. This opposition to the closing-spring is thrown out before the door is positively checked by the pawl.

Preferably in the upper part of the hinge a coiled counter-spring A is arranged, Figs.

2 and 5, having its upper end attached to a plate B, shown as sleeved upon the pintle A' of the hinge and resting upon the tubular pintle P. The lower end of the spring is shown attached to the plate C, which is loosely sleeved upon said pintle P. The plate B fits inside the shell of the hinge and has a lug *b*, preferably of tool-steel, which projects into and through a slot *e* in the shell. The plate C is flush with the shell, which is cut away at that point, C being provided on its outside face with several holes *c*, which, by means of a removable lug *c'*, fitting in one of said holes and bearing upon the face of the hinge E', Fig. 1, allows the adjustment of the tension of the spring to any desired degree.

It will be noted that on the closing of the door the hinge-leaf E', moving toward the leaf E, serves to further wind up the counter-spring A. When the leaves are close together, the lug *b* is in such a position that on the opening of the door a small spring-catch *e'*, carried by the leaf E', will catch the lug, so as to carry it back along its slot and wind up the spring A. The sloped projection *e*<sup>2</sup> as the door opens comes up under the spring-catch *e'* and finally raises it over the head of the lug B. The spring A is prevented from throwing back by the spring-pressed pawl F, Figs. 3, 4, and 5, whose lower edge slides along the upper surface of the plate B while the spring is being wound up by means of the catch *e'* and drops into a notch *f* in the upper face of the plate just as the catch passes over the top of the lug *b*. The pawl F is attached to the block G, sleeved upon the pintle A' and resting between the plate B and the upper knuckle E<sup>2</sup> of hinge-leaf E'. The pawl F has an arm which extends up through G into a circular channel *g*, cut in the upper part of the block. A screw-pin *g'*, carried by the upper knuckle E<sup>2</sup> of the leaf E' of the hinge, travels in this channel and serves, just before the check-pawl H impinges on the shoulder J, to trip the pawl F from the notch *f* in the top of the plate B and to release the spring. This throws the lug *b* back to its original position, the catch *e'* passing over it on its return in closing the door. By means of this device as the door is closed its movement is opposed by a force working counter to the closing-spring. The opening of the door serves to partially wind the retarding-spring by means of the catch *e'* and the lug *b*. Closing the door serves further to wind the spring by means of the lug *c'*. This slows down the door, so that the force of the blow from the check-pawl upon the block M may not be too great. When the spring A is released, the door does not move a sufficient distance before the check-pawl strikes the block to attain any great speed before it is brought to a stop.

Though I have described the counter-spring above, it may not be necessary or desirable to employ it in all cases. When the retracting-

spring is not used, the door-check is of very simple construction.

From the foregoing description it will be seen that the parts of my mechanical check may be easily attached to and put out of sight in the construction of the door-hinge.

I claim—

1. A door-check consisting of a hinge having in combination interfering projections carried by the opposite parts of the hinge, engaging with each other before the door is completely closed so as to check the closing movement, and moved out of engaging position after the door is checked to permit the final closing of the door, substantially as set forth.

2. In a door-check whose elements are attached to a door-hinge, the combination of a check-pawl, a channel in which the said check-pawl travels, a shoulder in the path of travel of said pawl, a channel or chamber into which the said pawl may pass after striking against the said shoulder, and means for causing said pawl to strike said shoulder and for causing said pawl to pass into said chamber, as the door is closed, substantially as set forth.

3. In a door-check whose elements are attached to a door-hinge, the combination of a check-pawl, a channel in which the said check-pawl travels, a shoulder in the path of travel of said pawl, a channel or chamber into which the said pawl may pass after striking against the said shoulder, and means for causing said pawl to strike said shoulder and for causing said pawl to pass into said chamber, and means for decreasing the sharpness of the blow of the said pawl upon the said shoulder, substantially as set forth.

4. In a door-check whose elements are attached to a door-hinge, the combination of a check-pawl, a channel in which the said check-pawl travels, a shoulder in the path of travel of said pawl, a channel or chamber into which the said pawl may pass after striking against the said shoulder, and means for causing said pawl to strike said shoulder and for causing said pawl to pass into said chamber, means for allowing a yielding movement to said shoulder under the blow of said pawl, and a device for retarding the movement of the door while swinging to, having means for suddenly decreasing the opposition of said device to the closing movement of the door before it is fully closed, substantially as set forth.

5. The combination of the leaves of a door-hinge with a check-pawl, a channel in which said check-pawl moves, having an offset *i*, and a chamber K, a shoulder formed in said channel means for holding the said pawl so as to strike said shoulder, springs connected with said shoulder, permitting it to give under the blow of said pawl, and means for causing said pawl to pass into said chamber K, after its contact with said shoulder, substantially as set forth.

6. In a door-check, a combination with the leaves of a door-hinge, of a spring-actuated

check-pawl attached to one leaf of the hinge, a catch-lever adapted to hold said check-pawl against its spring, a channel in the body of the hinge in which the end of said check-pawl travels, a lug in said channel for operating the catch-lever, a shoulder held by a spring in said channel and capable of a yielding movement when struck by said check-pawl, and a chamber connected with the channel into which said check-pawl may pass when not held by the catch-lever against its spring.

7. The combination of the leaves of a door-hinge and a door-checking device operating to bring the door to a full stop before it is shut with a spring connected to said leaves and means for adjusting the tension of the said spring, and means for increasing its tension on the opening of the door and partially releasing said tension when the door has reached a predetermined position, substantially as set forth.

8. The combination of the leaves of a door-hinge and a door-checking device operating to bring the door to a full stop with a spring A, connected to said leaves and operated by the movement thereof, a pawl F for holding said spring, the lug, *b*, adapted to be caught by spring-catch for holding said spring, and the pin, *g'*, for tripping said pawl, and releasing said spring, substantially as set forth.

9. In a door-check the combination with a door-checking device having a check-pawl of a movable block, having a shoulder against which the check-pawl of the checking device

strikes, and spring or springs connected with said block so as to allow the same yielding movement under the contact of said check-pawl, substantially as set forth.

10. In a door-check the combination with a door-checking device having a check-pawl of a movable block, and a shoulder against which the pawl of the checking device strikes, spring or springs connected with said block so as to allow the same a yielding movement under the contact of said pawl, and means for limiting the movement of said block against said springs, substantially as set forth.

11. The combination of the leaves of a hinge with a door-check substantially concealed in the structure of the hinge, and having a check-pawl working in a channel and adapted to impinge upon a shoulder in said channel, and springs connected with said shoulder and allowing the same a yielding movement, and a spring for retarding the closing movement of the door, having means operated by the opening movement of the door for increasing the strength of said spring, and means operated by the closing of the door for partially releasing said spring when the door is at a predetermined position, substantially as set forth.

This specification signed and witnessed this 3d day of September, 1896.

CHARLES F. HANINGTON.

Witnesses:

EUGENE CONRAN,  
GEORGE P. DYER.