

R. HINES.  
Saw-Filing Machines.

No. 148,701.

Patented March 17, 1874.

Fig 1.

Fig 4.

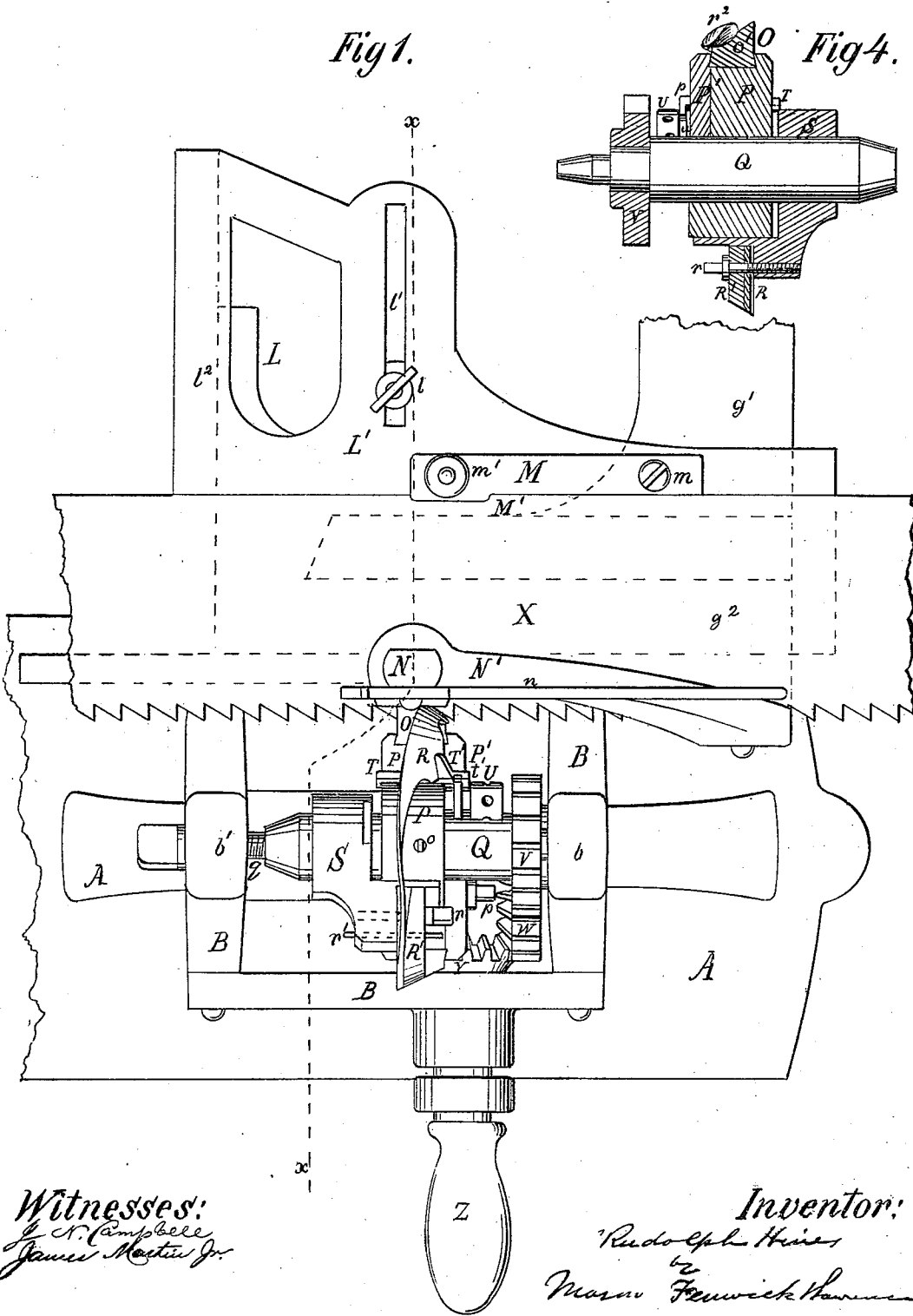

Witnesses:  
*J. N. Campbell*  
*James Masten Jr.*

Inventor:  
*Rudolph Hines*  
 by  
*Mason Fenwick Hannan*

R. HINES.  
Saw-Filing Machines.

No. 148,701.

Patented March 17, 1874.

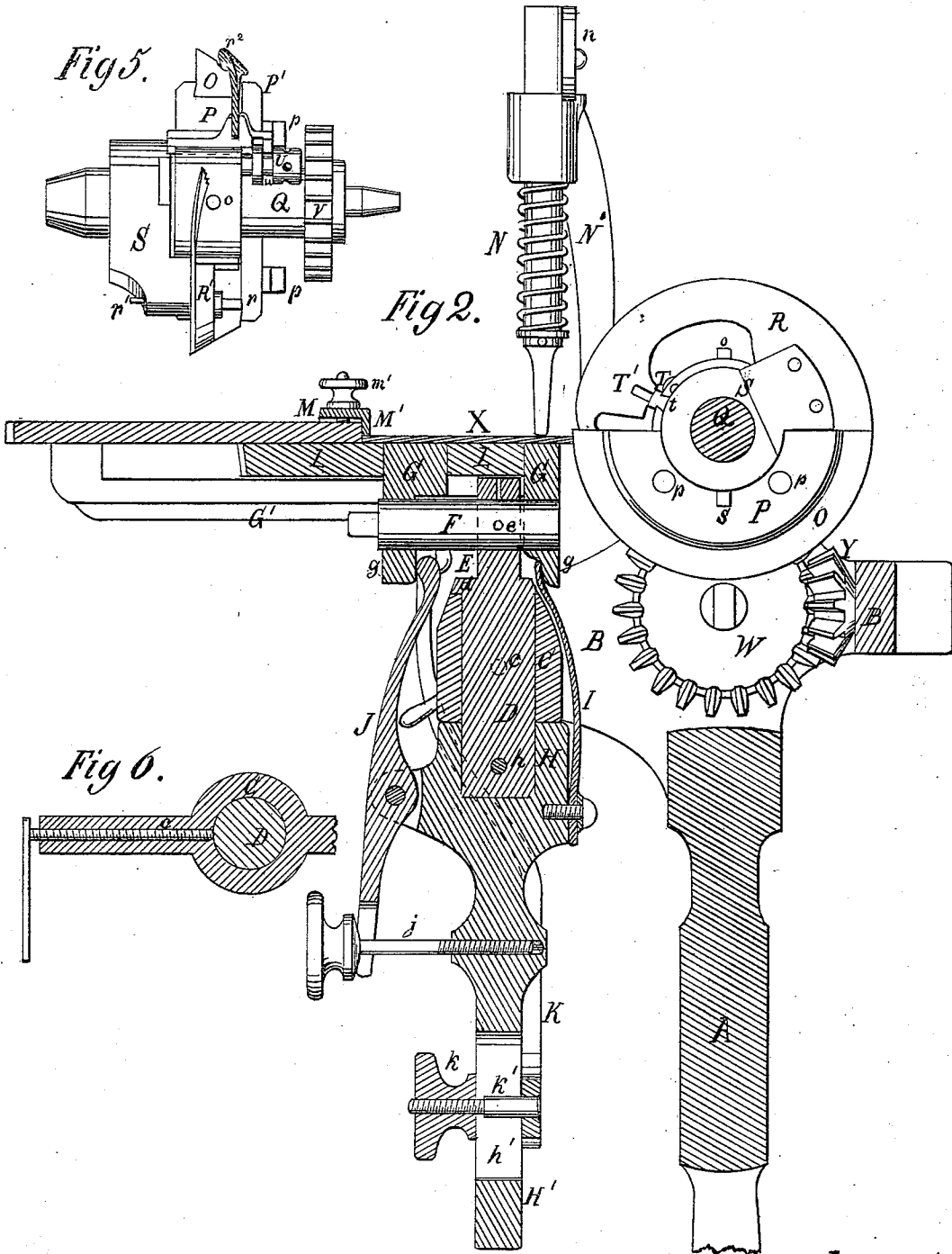

Witnesses:  
E. N. Campbell  
James Martin Jr.

Inventor:  
Rudolph Hines  
Mason Fenwick Hammer

R. HINES.  
Saw-Filing Machines.

No. 148,701.

Patented March 17, 1874.

Fig 3.

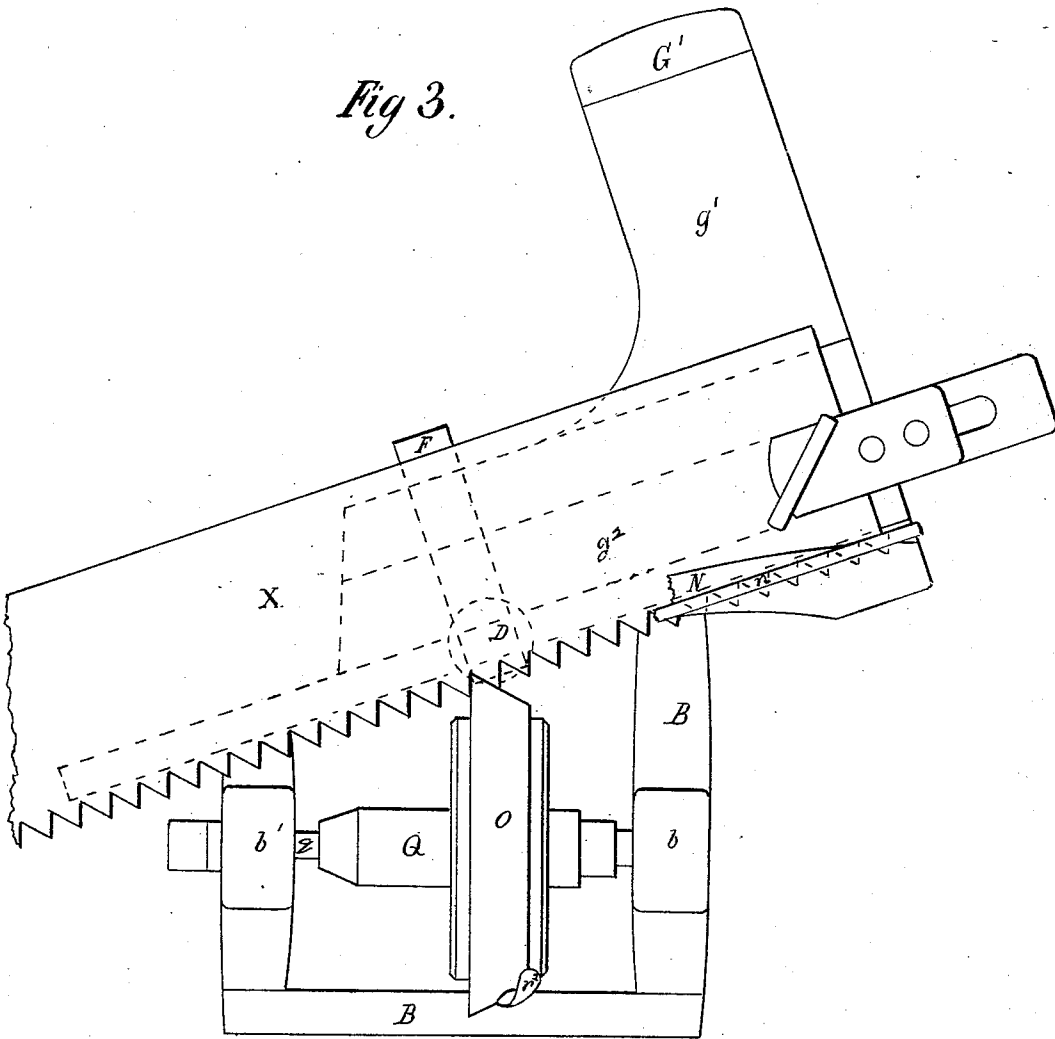

Witnesses:  
*L. N. Campbell.*  
*James Martin Jr.*

Inventor:  
*Rudolph Hines*  
*Mass*  
*James Fenwick Lawrence*

# UNITED STATES PATENT OFFICE.

RUDOLPH HINES, OF WASHINGTON, DISTRICT OF COLUMBIA.

## IMPROVEMENT IN SAW-FILING MACHINES.

Specification forming part of Letters Patent No. 148,701, dated March 17, 1874; application filed January 19, 1874.

*To all whom it may concern:*

Be it known that I, RUDOLPH HINES, of the city of Washington, in the District of Columbia, have invented certain new and useful Improvements in Saw-Filing Machines; and I do hereby declare that the following is a full, clear, and exact description thereof, reference being had to the accompanying drawings making part of this specification, in which—

Figure 1, Plate 1, in the drawings, represents a top view of my improved saw-filing machine. Fig. 2, Plate 2, is a vertical transverse section of the same in the line *x x* of Fig. 1. Fig. 3, Plate 3, is a diagram, showing the table swung around horizontally on its vertical pivot, to accomplish the filing of saw-teeth, such as represented. Fig. 4, Plate 1, is a longitudinal section through the file and feeder-shaft and its appendages. Fig. 5 is an elevation of the file and feeder-shaft with file and feeder upon it. A part of the feeder is broken away in order to show the sustaining-jaws more clearly. Fig. 6 is a detail section of the vertical shaft and its bearing and clamp-screw.

My invention relates to several improvements on the saw-filing machine patented July 20, 1871, by myself and Louis Beyer. The nature of my invention consists, first, in the rotary feeding-blade attached to its own independent hub by one end, in combination with a rotary file attached to its own independent hub, and having the other end of the feeder connected to it by an adjusting device. By this construction the combined feeder and filer is made much stronger and steadier than in our former patents, and both ends of the blade, whenever necessary to match the upright side of the file to that of the blade, may be adjusted together or separately, independently of the file-holder; and, further, the advantage of feeding the saw by the shoulder, instead of by the back of the tooth, is secured. Second, in connecting this feeding device by one of its ends to an adjustable and adjusting slide, formed with two stays, between which said end of the feeding-blade is confined. Third, the adjustable vertical turning-shaft, having a transverse hinging-pin near its upper end, in combination with the adjustable saw table or bed and the rotary file and feeder, whereby, with-

out changing the position of the feeder and file on its support, the saw can be adjusted in vertical and horizontal planes on its bed or table, and thus crosscut and almost every description of saw can be sharpened, the adjustments being all effected through the movement alone of the bed or table on which the saw is placed. Fourth, in a clamp and an adjustable or removable bed-plate with a gage-plate for saws with parallel backs, in combination with a pressure or holding-down foot. Fifth, in a table adapted by its formation to support the said adjustable bed-plate flush with its surface, and, when the plate is removed, is adapted for saws with saddle-backs, or with wooden or other frames, without elevating or lowering the shaft of the file and feeder.

A represents a stand, provided at the top with a square frame, B, one part of which has a boss, C, through which the upright shaft D passes. The said shaft is provided with a shoulder, *d*, and a head, E, in which the horizontal guide-pin F is secured by a set-screw, *e*, while the shaft D is prevented from turning by a set-screw, *c*. A table, G, is, with its lugs *g*, fitted on the ends of the pin F, so that it may turn or slide thereon. The lower end of the shaft D is passed into the socket-head H, and fastened thereto by a pin, *h*. At two opposite sides of the said socket-head the tension-spring I and the adjusting-lever J, the latter furnished with an adjusting set-screw, *j*, are attached, and made to bear with their upper ends on the inner sides of the lugs *g*, for the purpose of bringing the table G to the proper distance from the file. The table G is secured at the desired inclination on the pin F by the brace K, pivoted or hinged to one end of the table, and fastened by the bolt *k'* and thumb-screw *k* to the slotted tail-piece H' *h'*. The table G is provided at the top with a longitudinal groove, *g*<sup>2</sup>, and a depression, *g*<sup>1</sup>, in the arm G', into which a clamp-plate, L, is fitted, so that the said groove is thereby filled. To the top of the said clamp-plate a sliding gage, L', with an angular guide-flange, *l*<sup>2</sup>, is secured by means of the thumb-screw *l* in the slot *l*<sup>1</sup>, which latter constitutes the lateral adjustment for the gage, the front edge of which forms the back bearing and

guide for the saw-blade. On top of the gage L' is the clamp-plate M, fastened thereto at its off end by a set-screw, *m*, and provided at the other end with a vertical lip, M', which may be forced upon the saw X by a thumb-screw, *m'*, whereby the plate acts as a spring. A spring presser-foot, N, with a cam-lifter, *n*, attached to the arm N' on the table G, bears on the saw-blade near the file, and, with the aid of the clamp-plate M, prevents its rattling or jarring during the filing operation. The file O is a semicircular piece of hardened steel, with a dovetailed inner basis, and one vertical and one conical filing-surface, and is clamped by the set-screws *p* and the semicircular washer P' to the flange of the head P, which head is fastened to the arbor Q by a set-screw. The bearings of the shaft or arbor Q are the lug *b* and the tapered end of the adjusting set-screw *q* in the opposite lug *b'* of the frame B. The ridge of the file O is continued round by the spiral feeding-blade R, which, at the junction with it, is fastened to the head S by the clamp R', the set-screw *r*, and the steady-pin *r'*. The head S is adjusted on, and fastened to, the shaft Q by the set-screw *s*. The feeding portion of the blade R forms a spiral, which advances to the shoulder of the saw-tooth, and takes hold of the same by means of an inclined lip, *r''*, which projects over the other end of the file O, and for the reception of which there is a slight depression in the file O, to prevent its jamming against the saw-teeth in case they should be very small. The pitch of the feeding-blade is determined by a slide, T, which is fitted with a dovetail, *t*, into the hub of the file-head P, and is provided with a slotted head, T', through which the said feed-plate passes, and by which it is firmly kept in position. The adjustment of the slide is effected by a set-screw, U, which is fitted longitudinally into the hub of the file-head P, and is provided with a groove, *u*, in its cylindrical head, which receives the notched end *t'* of the slide T, whereby the slide is compelled to partake of the longitudinal movements of the screw U. The speed or motion of the shaft Q is secured through the wheels V W Y and the crank Z.

The advantages of my machine over the patented machine mentioned above are, first, the one machine is adapted for supporting, holding, and filing a great variety of saws, the spring presser-foot accommodating itself to

all irregularities of the surface of the saw, while the gage serves for holding saws of any width at top of back edge, and prevents jarring when the feeding takes place; second, the feeding of the saw by the shoulders of the teeth makes the line of operation of the feeding-blade almost, or wholly, parallel with the saw-blade itself, and reduces the friction ensuing thereby almost to a minimum; third, the angle of the tooth-shoulder may easily be varied by only swinging the table on its vertical shaft D, which makes no change whatever in the operation of filing, and the bevel may be changed or reversed by adjusting first in a vertical, and then in a horizontal, plane on opposite sides of the universal shaft.

What I claim as my invention, and desire to secure by Letters Patent, is—

1. The combination of the independent supporting-hub of the feeding-blade and the independent supporting-hub of the file, both placed upon the same shaft, and the feeding-blade being attached by one end adjustably to the hub which supports the file, and by its other end to its own hub, substantially in the manner and for the purpose set forth.

2. The adjustable slotted slide T T', in combination with the free or loose end of the feeding-blade and with the set-screw U, for the purpose of sustaining the said end of the blade on both sides, and also determining the pitch of the blade, all substantially in the manner set forth.

3. The vertical horizontally-adjustable turning-shaft having a transverse hinging-pin near its upper end, in combination with an adjustable file table or bed and a filing and feeding mechanism, substantially as and for the purpose set forth.

4. The adjustable or removable bed-plate, with gage and clamp attached, in combination with the presser-foot, substantially as described.

5. The table constructed with a depression, *g'*, which adapts it to receive the removable bed-plate with gage and clamp, and, when said bed-plate is removed, is adapted to receive the coverings on the backs of saws, substantially as described.

RUDOLPH HINES.

Witnesses:

J. N. CAMPBELL,  
J. TYLER POWELL.