

(19)



(11)

**EP 4 357 722 B1**

(12)

**EUROPEAN PATENT SPECIFICATION**

(45) Date of publication and mention of the grant of the patent:  
**12.03.2025 Bulletin 2025/11**

(51) International Patent Classification (IPC):  
**F41G 11/00<sup>(2006.01)</sup> F41G 1/35<sup>(2006.01)</sup>**

(21) Application number: **22202970.4**

(52) Cooperative Patent Classification (CPC):  
**F41G 11/003; F41G 1/35**

(22) Date of filing: **21.10.2022**

(54) **LIGHTING ASSEMBLY FOR A FIREARM, AND A FIREARM EQUIPPED WITH THE LIGHTING ASSEMBLY, AND AN ACTUATING ELEMENT FOR A LIGHTING ASSEMBLY**

BELEUCHTUNGSANORDNUNG FÜR EINE SCHUSSWAFFE UND MIT DER BELEUCHTUNGSANORDNUNG AUSGESTATTETE SCHUSSWAFFE UND BETÄTIGUNGSELEMENT FÜR EINE BELEUCHTUNGSANORDNUNG

ENSEMBLE D'ÉCLAIRAGE POUR ARME À FEU, ET ARME À FEU ÉQUIPÉE DE L'ENSEMBLE D'ÉCLAIRAGE, ET ÉLÉMENT D'ACTIONNEMENT POUR UN ENSEMBLE D'ÉCLAIRAGE

(84) Designated Contracting States:  
**AL AT BE BG CH CY CZ DE DK EE ES FI FR GB GR HR HU IE IS IT LI LT LU LV MC ME MK MT NL NO PL PT RO RS SE SI SK SM TR**

- **SEVELDA, Aaron**  
1030 Wien (AT)
- **STERN, Thomas**  
2125 Neubau (AT)

(43) Date of publication of application:  
**24.04.2024 Bulletin 2024/17**

(74) Representative: **Burger, Hannes**  
**Anwälte Burger & Partner**  
**Rechtsanwalt GmbH**  
**Rosenauerweg 16**  
**4580 Windischgarsten (AT)**

(73) Proprietor: **Glock Technology GmbH**  
**9170 Ferlach (AT)**

(72) Inventors:  
• **SPITZER, Tobias**  
**9020 Klagenfurt (AT)**

(56) References cited:  
**US-A1- 2018 283 670 US-A1- 2019 154 243**  
**US-A1- 2019 301 835 US-A1- 2021 025 568**

**EP 4 357 722 B1**

Note: Within nine months of the publication of the mention of the grant of the European patent in the European Patent Bulletin, any person may give notice to the European Patent Office of opposition to that patent, in accordance with the Implementing Regulations. Notice of opposition shall not be deemed to have been filed until the opposition fee has been paid. (Art. 99(1) European Patent Convention).

**Description**

**[0001]** The invention relates to a lighting assembly for a firearm, and a firearm equipped with the lighting assembly, and an actuating element for a lighting assembly.

5 **[0002]** The firearm according to the invention can preferably be a pistol, but it can also be a rifle, carbine, submachine gun, shotgun, etc. Firearms are guns that can be carried and used by one person.

**[0003]** The lighting assembly may comprise one or more light sources and emit, for example, light and/or LASER light in the visible and/or non-visible range (for example infrared).

10 **[0004]** Firearm users vary in physique. In particular, the hands of the firearm users are of different sizes. There has long been a need to be able to adapt a firearm to different users. Particularly when a firearm is equipped with add-on parts, such as a lighting assembly, there should be flexible adaptability to the user and the lighting assembly should be easy to operate.

**[0005]** US 11105586 B2 discloses a lighting assembly for a firearm. The lighting assembly is longitudinally slidably received on a firearm frame assembly. The position of the lighting assembly relative to the frame assembly is adjustable.

**[0006]** Although US 11105586 B2 features adaptability of the lighting assembly to the user, it is only insufficient.

15 **[0007]** Another lighting assembly is known from US 2022042675 A1. This, too, has only insufficient adaptability to the user.

**[0008]** Another lighting assembly is known from US2021025568A1. This, too, has only insufficient adaptability to the user.

20 **[0009]** The object of the present invention is to overcome the disadvantages of the prior art and to provide an improved lighting assembly for a firearm, and a firearm equipped with the lighting assembly, and an actuating element for the lighting assembly.

**[0010]** This object is achieved by a lighting assembly and a firearm according to the claims.

**[0011]** According to the invention, a lighting assembly is designed for a firearm. The lighting assembly comprises:

- 25 - a housing with an interior for receiving electronic components, wherein the housing extends in a longitudinal direction;
- a light source, wherein the light source is received in the interior of the housing;
- 30 - a first switch, which is used for switching the light source, wherein the first switch is received in the interior of the housing;
- a first actuating element receptacle for receiving a first actuating element, which is used for actuating the first switch,

wherein the first actuating element receptacle is arranged at a first position of the housing.

35 **[0012]** The first actuating element receptacle is designed in such a way that the first actuating element in the form of a first pressing actuator can be received in the first actuating element receptacle, wherein the first pressing actuator can be slid along a linear direction, in particular along the longitudinal direction, relative to the housing, and wherein the first switch can be actuated by the sliding in the linear direction of the first pressing actuator relative to the housing and that the first actuating element in the form of a first rocking actuator can be received in the first actuating element

40 receptacle, wherein the first rocking actuator can be pivoted about a first pivot axis, in particular about a first vertical axis, relative to the housing, and wherein the first switch can be actuated by the pivoting of the first rocking actuator relative to the housing.

**[0013]** The lighting assembly according to the invention has the advantage that the actual functionality of the first actuating element can be freely configured due to the fact that both a pressing actuator and a rocking actuator can be

45 received in the first actuating receptacle. Thus, depending on the requirement, for example a pressing actuator or a rocking actuator may be inserted into the first actuating receptacle. Thus, for example, a pressing actuator or a rocking actuator may be used in the first actuating receptacle. If different actuators are made available to the user, he can configure a pressing actuation or a rocking actuation according to his wishes. The free choice of different actuators allows the adaptability of the firearm to be improved.

50 **[0014]** Furthermore, it may be provided that the following components are formed:

- a second switch, which is used for switching the light source, wherein the second switch is received in the interior of the housing;
- 55 - a second actuating element receptacle for receiving a second actuating element, which is used for actuating the second switch.

**[0015]** In addition, the second actuating element receptacle may be designed in such a way that the second actuating

element in the form of a second pressing actuator can be received in the second actuating element receptacle, wherein the second pressing actuator can be slid along a linear direction, in particular along the longitudinal direction, relative to the housing, and wherein the second switch can be actuated by the sliding in the linear direction of the second pressing actuator relative to the housing, and that the second actuating element in the form of a rocking actuator can be received in the second actuating element receptacle, wherein the rocking actuator can be pivoted about a vertical axis relative to the housing, and wherein the second switch can be actuated by the pivoting of the rocking actuator relative to the housing.

**[0016]** These features have the advantage that the actual functionality of the first actuating element and the second actuating element can be freely configured due to the fact that both a pressing actuator and a rocking actuator can be received in the first actuating receptacle and also in the second actuating receptacle. Thus, depending on the requirement, for example a pressing actuator or a rocking actuator may be inserted into the first actuating receptacle or into the second actuating receptacle. Thus, for example, a pressing actuator may be used in the first actuating receptacle and a rocking actuator may be used in the second actuating receptacle. If different actuators are made available to the user, he can configure a pressing actuation or a rocking actuation according to his wishes. The free choice of different actuators allows the adaptability of the firearm to be improved.

**[0017]** Furthermore, it may be provided that the first actuating element receptacle is arranged on a left side of the housing with respect to the longitudinal direction and the second actuating element receptacle is arranged on a right side of the housing with respect to the longitudinal direction. This measure allows the lighting assembly to be adapted to both left-handed and right-handed users.

**[0018]** In an alternative embodiment variant it may also be provided that the first actuating receptacle is only arranged on the left side of the housing and no actuating receptacle is formed on the right side of the housing.

**[0019]** In an alternative embodiment variant it may also be provided that the first actuating receptacle is only arranged on the right side of the housing and no actuating receptacle is formed on the left side of the housing.

**[0020]** In a further alternative embodiment variant it may also be provided that the actuating receptacle is arranged on an upper side or on an underside of the housing.

**[0021]** In yet another embodiment variant it may also be provided that the first actuating receptacle and the second actuating receptacle are arranged next to one another or one above the other on the housing.

**[0022]** An actuating element which is used for actuating the switch by being slid in the longitudinal direction relative to the housing is referred to as a pressing actuator. In particular, the pressing actuator can be pressed forward in the longitudinal direction by means of a finger of the user.

**[0023]** An actuating element which is received in the actuating element receptacle such that it can pivot about a pivot axis, so that the switch can be switched by lateral pressure on the rocking actuator, is referred to as a rocking actuator.

**[0024]** Furthermore, it may be expedient if the first actuating element is designed in the form of a first combination actuator with pressing functionality and rocking functionality. This has the advantage that, with only one configuration of an actuator, it can be actuated both by axial sliding and by rocking. The total number of different components can thus be reduced and thus the complexity of storage can be reduced.

**[0025]** Furthermore, it may be provided that the second actuating element is designed in the form of a second combination actuator with pressing functionality and rocking functionality. This has the advantage that, with only one configuration of an actuator, it can be actuated both by axial sliding and by rocking. The total number of different components can thus be reduced and thus the complexity of storage can be reduced.

**[0026]** Furthermore, it is also conceivable that when using a combination actuator, the sliding function or the rocking function is blocked by means of a blocking element, such as a pin. If the pin is inserted in the front area, it can be used to block the sliding function. If the pin is inserted in the rear area, it can be used to block the rocking function. This allows the sliding-rocking combination to be optionally converted into just a sliding function or just a rocking function.

**[0027]** Furthermore, it may be provided that a transverse return spring is formed, wherein the transverse return spring is received in a return spring channel in such a way as to be guided transversely in the housing and acts on the first actuating element. Furthermore, it may be provided that the transverse return spring acts on the first actuating element and the second actuating element at the same time. This has the advantage that the first actuating element and the second actuating element can be held in their rest position by the transverse return spring.

**[0028]** In addition, it may be provided that an unlocking clearance, which opens into the return spring channel, is formed in the housing, wherein the transverse return spring located in the return spring channel is accessible through the unlocking clearance and, by using a tool, can be disengaged from the first actuating element and/or the second actuating element. This has the advantage that it is possible to reach into the return spring channel through the unlocking clearance in order to disengage it from the first actuating element or the second actuating element. This measure allows the first actuating element or the second actuating element to be removed from the actuating element receptacle.

**[0029]** Also advantageous is an embodiment according to which it may be provided that a protective cover, which closes the unlocking clearance, is formed. This has the advantage that this measure can prevent dirt from penetrating into the return spring channel. In particular, it may be provided that the protective cover is formed from a flexible material, in particular from a rubber-like material. The protective cover may have a protective cover pin which is designed to be pressed

into the unlocking clearance or into another clearance arranged in the housing, such as a bore for receiving a screw. In this case, the protective cover pin can be made slightly larger than the unlocking clearance or the other clearance, so that the protective cover is held in the unlocking clearance or in the other clearance.

**[0030]** According to a development, it is possible that the transverse return spring acts at the same time as a anti loss protection device for when the first actuating element is received in the first actuating element receptacle and/or

that the transverse return spring acts at the same time as a anti loss protection device for when the second actuating element is received in the second actuating element receptacle. This has the advantage that the number of components can be kept low.

**[0031]** Furthermore, it may be expedient if, in the case of the first actuating element if it is designed in the form of the first pressing actuator, a first clearance is formed, which has a longitudinal extent in the longitudinal direction, wherein the longitudinal extent of the first clearance in the longitudinal direction is greater than a longitudinal extent of the transverse return spring in the longitudinal direction, wherein the first clearance together with the transverse return spring are used as an axial stop for limiting the axial sliding of the first pressing actuator along the longitudinal direction relative to the housing.

This has the advantage that the transverse return spring acts as a anti loss protection device for the actuating element and at the same time limits the path of the actuating element.

**[0032]** In addition, it may be provided that, in the case of the first actuating element if it is designed in the form of the first pressing actuator, a depression with a depression ramp is formed, wherein the depression ramp is formed at a ramp angle to the longitudinal direction. This has the advantage that the depression or the depression ramp allows sliding of the actuating element in the longitudinal direction to be converted into a pressing movement for actuating the switch. The depression ramp can act here as a transmission.

**[0033]** Furthermore, it may be provided that, in the case of the first actuating element if it is designed in the form of the first pressing actuator, a first longitudinal return spring is formed. This measure makes it possible for the actuating element to be able to be returned to its starting position again after it has been pressed and thus after it has been slid in the longitudinal direction. In particular, it may be provided here that the first longitudinal return spring acts in the longitudinal direction or is formed in the longitudinal direction.

**[0034]** According to one particular embodiment, it is possible that the first actuating element receptacle and the second actuating element receptacle are formed symmetrically with respect to a central housing plane and that the first actuating element is formed symmetrically, at least in some sections, about a horizontal central plane, so that the first actuating element can be optionally used in the first actuating element receptacle or in the second actuating element receptacle. This has the advantage that the first actuating element may be used in the second actuating element receptacle and the second actuating element may be used in the first actuating element receptacle. Thus, one of the two actuating elements may be designed as a pressing actuator and the second of the two actuating elements may be designed as a rocking actuator, with the user being free to choose which of the actuating elements is inserted into the first actuating element receptacle and which of the actuating elements is inserted into the second actuating element receptacle. Thus, only two different types of actuating elements need to be supplied in order to achieve free configurability by the user. In addition, this measure allows the lighting assembly to be easily converted by the user from left-handed use to right-handed use without the need for additional components.

**[0035]** According to an advantageous development, it may be provided that different first actuating elements, which have a different overall length, are formed. This has the advantage that the different actuating elements allow the lighting assembly to be able to be easily adapted to the different physical requirements of different users. For example, an actuating element with a greater overall length can be used for users with shorter fingers, so that these users can easily reach or actuate the actuating element.

**[0036]** Furthermore, it is also conceivable that different first actuating elements are formed, which have other different properties, such as for instance different haptic characteristics of the user interface, a different material, a different colour, or some other individualization.

**[0037]** In particular, it may be advantageous if a front guiding clearance is formed in the first actuating element receptacle, wherein the front guiding clearance extends in the longitudinal direction, wherein the front guiding clearance has at its front end a guiding clearance base with a rounding, wherein the first actuating element has a pivot bearing section which corresponds to the rounding of the front guiding clearance, wherein the pivot bearing section forms with the guiding clearance base a pivot axis about the vertical axis. This has the advantage that an articulated reception of the actuating element in the actuating element receptacle can be achieved by this measure, so that a pressing movement in the transverse direction on the actuating element can be converted into a switching movement of the switch.

**[0038]** Furthermore, it may be provided that a lower guiding clearance is formed in the first actuating element receptacle, wherein the first actuating element has a lower guiding lug, which corresponds to the lower guiding clearance. This has the advantage that the lower guiding clearance allows longitudinal guidance of the actuating element to be achieved. In particular, it may be provided that the lower guiding lug is received in the lower guiding clearance in such a way that it can be slid in the longitudinal direction.

**[0039]** In addition, it may be provided that the lower guiding clearance has an outer guiding surface facing a central housing plane, wherein the outer guiding surface is at a varying distance from the central housing plane when viewed in the longitudinal direction. Such a measure makes it possible for a longitudinal sliding of the actuating element to be able to be converted into a pressing movement of the actuating element, as a result of which an actuating element with a combined rocking function and pressing function can be achieved.

**[0040]** Furthermore, a firearm can be designed. The firearm comprises:

- a lighting assembly, which is received on the firearm, or is at least partially integrally formed on the firearm.

**[0041]** Furthermore, it may be provided that a mounting rail, preferably a mounting rail of a frame, is formed, wherein the lighting assembly is removably received on the mounting rail.

**[0042]** At this point, reference is also made to EP3892954A1 from the same applicant, which describes such a connection of a firearm to an accessory such as a lighting assembly.

**[0043]** However, the lighting assembly or its housing may also be connected to the firearm in a different way, for example a clamped connection by means of clamping jaws or direct attachment by means of a screw connection or bolts is conceivable. An integral design of the housing or a housing part with the firearm is also conceivable. The way in which the lighting assembly is connected to the firearm is not essential to the present invention, but is only described for the sake of completeness.

**[0044]** The mounting rail may be formed, for example, on the frame of a pistol below the barrel. However, the mounting rail may also be formed on the top, side or bottom of the receiver or handguard of a rifle. The mounting rail may be designed for example as a dovetail rail. One type of dovetail rail may be for example a Picatinny or Weaver rail. However, other designs, for example a T-slot, are also possible.

**[0045]** The firearm has the advantage that the actual functionality of the first actuating element and the second actuating element can be freely configured due to the fact that both a pressing actuator and a rocking actuator can be received in the first actuating receptacle and also in the second actuating receptacle. Thus, depending on the requirement, for example a pressing actuator or a rocking actuator may be inserted into the first actuating receptacle or into the second actuating receptacle. Thus, for example, a pressing actuator may be used in the first actuating receptacle and a rocking actuator may be used in the second actuating receptacle. If different actuators are made available to the user, he can configure a pressing actuation or a rocking actuation according to his wishes. The free choice of different actuators allows the adaptability of the lighting assembly to be improved.

**[0046]** Furthermore, it may be provided that the housing is of a multi-part design, wherein the housing has a main housing part and a housing cover, wherein the first actuating receptacle and the second actuating receptacle are arranged in the housing cover.

**[0047]** Furthermore, it may be provided that a first guiding groove and a second guiding groove are formed directly in a main housing part of a housing of the lighting assembly, wherein a first guiding lug corresponding to the first guiding groove and a second guiding lug corresponding to the second guiding groove are formed on the frame, wherein the lighting assembly can be pushed axially onto the guiding lugs of the frame, wherein a securing element, which may for example be designed as a securing pin or a securing shaft, is arranged in the housing and extends from the side of the first guiding groove to the side of the second guiding groove and below the first guiding groove and the second guiding groove is arranged in the main housing part, wherein the securing element has a securing lug, wherein the securing lug can optionally be brought into securing engagement with the frame by rotating the securing element about its axis of rotation.

**[0048]** Furthermore, it may be provided that the first switch and the second switch are each in the form of a microswitch.

**[0049]** Furthermore, it may be provided that the lighting assembly comprises the following components:

- a housing with an interior for receiving electronic components;
- a light source, which is received in the interior of the housing;
- a switch, which is used for switching the light source on and off, wherein the switch is received in the interior of the housing;
- a sealing element, which is used for sealing off the interior of the housing from the environment, wherein the sealing element has an inner side facing the interior of the housing and an outer side;
- an actuating element, which is used for actuating the switch,

wherein a force transmission element is formed, wherein the force transmission element is embedded in the sealing element, wherein the force transmission element is designed for force transmission from the actuating element to the

switch.

**[0050]** The measures have the advantage that the force transmission element, which is embedded in the sealing element, allows an improved transmission of force between the actuating element and the switch to be achieved. As a result, the response of the switch when the actuating element is actuated can be improved. This simplifies the handling of a firearm equipped with the lighting assembly. The improved response of the switch can be achieved in that the overlapping of the sealing element with the force transmission element can be kept as small as possible, as a result of which the flexibility of the sealing element exerts the least possible disruptive influence on the force transmission. In addition, the lighting assembly can be flexibly equipped with a rocking actuator or a pressing actuator.

**[0051]** In particular, it may be provided that the force transmission element is embedded in a force transmission element receptacle. In particular, it may be provided that the force transmission element is received in a form-fitting manner in the force transmission element receptacle.

**[0052]** Furthermore, it may be provided that the force transmission element receptacle is designed in the form of a spherical cap and is open to the outer side.

**[0053]** In particular, it may be provided that an opening on the outer side has a smaller cross section than the cavity behind it for receiving the force transmission element.

**[0054]** Furthermore, it may be expedient if the sealing element is formed from a first material and that the force transmission element is formed from a second material, wherein the second material has a higher modulus of elasticity than the first material. This measure makes it possible for the sealing element to have sufficient flexibility to be deformed for force transmission and the force transmission element to have sufficient rigidity to be able to be used for force transmission.

**[0055]** Furthermore, it may be provided that the sealing element is formed from a rubber-elastic material and that the force transmission element is formed from a metallic material. Good force transmission properties can be achieved particularly with such a combination of materials.

**[0056]** In addition, it may be provided that the force transmission element is designed in the form of a sphere. A force transmission element in the form of a sphere has the advantage that efficient force transmission can be achieved for actuating elements of different designs.

**[0057]** Also advantageous is an embodiment according to which it may be provided that the spherical shape of the force transmission element is embedded by more than 50% in the sealing element. This has the advantage that the force transmission element can be captively retained when it is received in the sealing element. In particular, it may be provided that the flexibility of the sealing element allows the force transmission element to be slidable relative to the housing.

**[0058]** According to a development, it is possible that the force transmission element is not surrounded by the sealing element on the outer side and is designed for direct contact with the actuating element. This has the advantage that the direct contact of the force transmission element with the actuating element allows an improved and direct response to be achieved.

**[0059]** Furthermore, it may be expedient if the force transmission element is covered on the inner side by the sealing element, so that the force transmission element is designed for indirect contact with the switch, with the sealing element interposed. This has the advantage that improved sealing off of the interior can be achieved by this measure. The electrical components received in the interior are thus better protected.

**[0060]** In addition, it may be provided that the housing is of a multi-part design, wherein the housing has a main housing part and a housing cover, wherein an actuating element receptacle for receiving the actuating element is formed in the housing cover. This has the advantage that, by this measure, the electrical components received in the housing can be easily inserted into it.

**[0061]** Furthermore, it may be provided that the sealing element is formed as a separate component which is received in the housing, in particular in the housing cover. This has the advantage that the sealing element can be easily replaced.

**[0062]** According to a particular embodiment, it is possible that the sealing element is injection-moulded in a clearance of the housing cover, so that the sealing element is inseparably coupled to the housing cover. This has the advantage that this measure makes it easy to manufacture the lighting assembly and, moreover, it can have a robust structure.

**[0063]** Furthermore, it may be provided that the sealing element is arranged in the form of a shell on the inner side of the housing cover or is adapted to it.

**[0064]** In addition, it may be provided that the sealing element rests circumferentially on the main housing part in order to achieve a seal between the interior of the housing and the environment.

**[0065]** In addition, it may be provided that the sealing element has a flange which is clamped between the housing cover and the main housing part in order to achieve a seal between the interior of the housing and the environment.

**[0066]** A firearm frame assembly may also be provided. The frame assembly comprises:

- a lighting assembly removably received on the frame.

**[0067]** In particular, it may be advantageous if a first guiding groove and a second guiding groove are formed directly in a

main housing part of a housing of the lighting assembly, wherein a first guiding lug corresponding to the first guiding groove and a second guiding lug corresponding to the second guiding groove are formed on the frame, wherein the lighting assembly can be pushed in the longitudinal direction onto the guiding lugs of the frame, wherein a securing element, which extends from the side of the first guiding groove to the side of the second guiding groove and below the first guiding groove and the second guiding groove is arranged in the main housing part, is arranged in the housing, wherein the securing element has a securing lug, wherein the securing lug can optionally be brought into securing engagement with the frame by rotating the securing element about its axis of rotation. This has the advantage that the lighting assembly can be easily received on the frame.

**[0068]** In particular, it may be provided that the light source is not received directly in the interior of the housing, but is received in the front housing cover and together with it is partially pushed into the interior of the housing.

**[0069]** The area that is located within the outer housing shell can be referred to as the interior of the housing.

**[0070]** Within the meaning of this document, switching the light source can be understood as switching on, switching off, switching between different brightness levels, switching between different lighting modes, switching between different colours, wavelengths (for example visible, infrared) and frequency ranges (for example laser) and the like.

**[0071]** For a better understanding of the invention, it is explained in more detail with reference to the following figures.

**[0072]** They respectively show in a greatly simplified, schematic representation:

Fig. 1 an exploded representation of a first exemplary embodiment of a firearm in a perspective view;

Fig. 2 another perspective view of the firearm in the assembled state;

Fig. 3 an exploded representation of a first exemplary embodiment of a lighting assembly in a perspective view;

Fig. 4 a sectional representation of the first exemplary embodiment of the lighting assembly according to section line IV-IV in Fig. 3;

Fig. 5 a sectional representation of an exemplary embodiment of the lighting assembly with extended actuators;

Fig. 6 a side view of an exemplary embodiment of a symmetrically constructed rocking actuator for use in the first actuating receptacle or in the second actuating receptacle;

Fig. 7 a sectional representation of a further exemplary embodiment with a combination actuator according to section line VII-VII in Fig. 3;

Fig. 8 an exploded representation of a housing cover in a perspective view.

**[0073]** As an introduction, it should be noted that in the differently described embodiments the same parts are provided with the same reference numerals or the same component designations, it being possible for the disclosures contained throughout the description to be applied analogously to the same parts with the same reference numerals or the same component designations. The positional indications chosen in the description, such as top, bottom, left, right, side, etc., refer to the state of use of the firearm.

**[0074]** Fig. 1 shows an exploded representation of a first exemplary embodiment of a firearm 1 in the example of a pistol in a perspective view.

**[0075]** As can be seen from Fig. 1, it may be provided that the firearm 1 comprises a slide assembly 2. Furthermore, it may be provided that the firearm 1 comprises a frame assembly 3. The slide assembly 2 and the frame assembly 3 are shown spaced apart from each other in the representation of Fig. 1.

**[0076]** In particular, it may be provided that, in the state of use of the firearm 1, the slide assembly 2 is coupled to the frame assembly 3.

**[0077]** The slide assembly 2 may comprise a barrel 4. The frame assembly 3 may comprise a frame 5.

**[0078]** A magazine receiving space 6, which is used for receiving a magazine 7 pushed into it, may be formed in the frame 5. The magazine 7 can be inserted in the frame 5 in a magazine insertion direction 8.

**[0079]** As can also be seen from Fig. 1, it may be provided that a slide rail 9 for receiving the slide assembly 2 is formed on the frame 5.

**[0080]** In particular, it may be provided that the frame 5 is formed as an injection-moulded part of plastic.

**[0081]** As can also be seen from Fig. 1, it may be provided that a mounting rail is formed on the frame 5 below the barrel 4 and a lighting assembly 10 is received on the mounting rail.

**[0082]** A special alignment of the linear direction, specifically in the longitudinal direction 11 of the lighting assembly 10, extends parallel or at least approximately parallel to the barrel 4 when the lighting assembly 10 is in the installed state. In

other embodiments, however, the linear direction can also assume a different position, for example vertical to the barrel or obliquely along an outer surface of the housing 12 of the lighting assembly 10. The muzzle of the barrel 4 is in the front. The slide assembly 2 is located on top of the frame assembly 3. The positional indications left and right relate to a position as shown in Fig. 1. Here, the left side faces the viewer and the right side faces away from the viewer. In the exemplary embodiment represented, the first position is referred to as the left side. The second position is referred to as the right side. Accordingly, the first components may be located on the left side of the lighting assembly 10 and the second components may be located on the right side of the lighting assembly 10.

**[0083]** The firearm 1, in particular the slide assembly 2 and the frame assembly 3, may of course comprise other common components known to a person skilled in the art, such as for instance a trigger, etc., reference being made here to general specialist knowledge and these components therefore not described separately for the sake of clarity.

**[0084]** Fig. 2 shows the firearm 1 in a further perspective view, with the same reference numerals or component designations as in the preceding Fig. 1 being used again for the same parts. In order to avoid unnecessary repetitions, reference is made to the detailed description in the preceding Fig. 1.

**[0085]** As can be seen by looking at Figures 1 and 2 together, it may be provided that the lighting assembly 10 has a housing 12. The housing 12 may comprise a main housing part 13. Furthermore, it may be provided that the housing 12 comprises a housing cover 14. The housing cover 14 may be arranged on a rear side of the main housing part 13. In particular, it may be provided that the housing cover is coupled to the main housing part 13 by means of fastening means, in particular by means of screws.

**[0086]** Furthermore, it may be provided that the housing 12 comprises a front housing cover 15. The front housing cover 15 may be arranged on a front side of the main housing part 13. In particular, it may be provided that the front housing cover 15 is coupled to the main housing part 13 by means of a form-fitting connection, in particular by means of a bayonet connection.

**[0087]** In particular, it may be provided that the main housing part 13 is formed in one piece. The main housing part 13 may be formed here for example as a die-cast part of aluminium. Furthermore, it is also conceivable that the main housing part 13 is formed as an injection-moulded part of a plastic. In addition, it is also conceivable that the main housing part 13 is milled from a block of solid material or a semi-finished product or is manufactured additively.

**[0088]** Furthermore, it may be provided that a first guiding groove 16 and a second guiding groove 17 are formed in the main housing part 13. A first guiding lug 18 corresponding to the first guiding groove 16 and a second guiding lug 19 corresponding to the second guiding groove 17, which may be formed in particular in the form of a mounting rail, may be formed on the firearm 1, in particular on the frame 5. As a result, the lighting assembly 10 can be pushed onto the guiding lugs 18, 19 axially or in the longitudinal direction 11.

**[0089]** In an alternative embodiment variant that is not shown, it may also be provided that the lighting assembly 10 is designed at least partially as an integral part of the firearm 1.

**[0090]** In yet another embodiment variant, it may also be provided that the lighting assembly 10 is coupled to the firearm 1 by means of a screw connection.

**[0091]** Furthermore, it may be provided that a securing element 20, for example a securing pin or a securing shaft, is arranged in the housing 12 and extends from the side of the first guiding groove 16 to the side of the second guiding groove 17 and below the first guiding groove 16 and the second guiding groove 17 is arranged in the main housing part 13. The securing element 20 may have a securing lug 21, wherein the securing lug 21 can optionally be brought into securing engagement with the frame 5 by rotating the securing element 20 about its axis of rotation 22.

**[0092]** Fig. 3 shows a further embodiment of the lighting assembly 10, which may be independent in itself, with the same reference numerals or component designations as in the preceding Figures 1 and 2 being used again for the same parts. In order to avoid unnecessary repetitions, reference is made to the detailed description in the preceding Figures 1 and 2.

**[0093]** In Fig. 3, the individual components of the lighting assembly 10 are shown in an exploded representation. As shown in Fig. 3, an interior 23 of the housing 12 may be formed within the main housing part 13, the housing cover 14 and the front housing cover 15. In particular, it may be provided that the interior 23 is mainly formed in the main housing part 13, wherein the main housing part 13 is closed by the housing cover 14 and the front housing cover 15. Parts of the housing cover 14 and the front housing cover 15 which protrude into the main housing part 13 can thus be arranged in the interior 23 of the housing 12. However, components are also considered to be arranged in the interior 23 of the housing 12 if they are located exclusively in the housing cover 14 or in the front housing cover 15.

**[0094]** It may also be provided that a light source 24 is arranged in the interior 23. The light source 24 may for example be formed as an LED and emit light and/or LASER light in the visible and/or non-visible range (for example infrared). In particular, it may be provided here that the light source 24 is integrated directly in the front housing cover 15. The interior 23 may also be used for receiving a battery or for receiving a rechargeable battery. Furthermore, it may be provided that a contact 25, which can be used for contacting the battery or the rechargeable battery, is formed in the front housing cover 15. Furthermore, it may be provided that one or more sealing rings 26, which act between the front housing cover 15 and the main housing part 13, are arranged on the front housing cover 15. The sealing rings 26 can be used for sealing off the interior 23.

**[0095]** As can also be seen from Fig. 3, it may be provided that a securing element receptacle 27 is formed in the main housing part 13. The securing element receptacle 27 may be formed as a bore which extends in a transverse direction 28 in the main housing part 13. The securing element receptacle 27 may also have shaped clearances, which are used for receiving the securing lug 21 of the securing element 20.

**[0096]** As can also be seen from Fig. 3, it may be provided that a switching mechanism for switching the light source 24 on and off is formed in the housing 12, in particular in the housing cover 14. The switching mechanism may be coupled to switching electronics. The switching electronics can be programmed differently according to different requirements.

**[0097]** In Fig. 4, the lighting assembly 10 of the exemplary embodiment from Fig. 3 is shown in the assembled state in a sectional representation according to the section line IV - IV from Fig. 3, with the same reference numerals or component designations as in the preceding Figures 1 to 3 being used again for the same parts. In order to avoid unnecessary repetitions, reference is made to the detailed description in the preceding Figures 1 to 3.

**[0098]** The further description of the structure of the lighting assembly 10 takes place in a synopsis of Figs. 3 and 4. As can be seen particularly well from Fig. 4, it may be provided that a first switch 29 and a second switch 30, which are used for switching the light source 24, are formed. In particular, it may be provided that the switches 29, 30 are used for switching the light source 24 by means of the switching electronics.

**[0099]** Furthermore, a first actuating element 31 may be provided. The first actuating element 31 may be used for actuating the first switch 29. In particular, the first actuating element 31 may be used for actuation by a user. The first actuating element 31 can be received in a first actuating element receptacle 32. The first actuating element receptacle 32 may be formed here in the housing cover 14.

**[0100]** Furthermore, a second actuating element 33, which can be received in a second actuating element receptacle 34, may be formed. The second actuating element 33 may be used for actuating the second switch 30. The second actuating element receptacle 34 may be formed here in the housing cover 14.

**[0101]** In particular, it may be provided that the housing cover 14 is formed symmetrically about a central housing plane 35. The first actuating element receptacle 32 and the second actuating element receptacle 34 can thus be designed symmetrically to one another, at least in their basic features or in their main shape.

**[0102]** Functional details of the first actuating element receptacle 32 and the first actuating element 31 are described below. Due to the symmetry of the first actuating element receptacle 32 and the second actuating element receptacle 34, it is clear to a person skilled in the art or it is within the ability of a person skilled in the art to also provide the functional details described for the first actuating element receptacle 32 in the second actuating element receptacle 34 or the second actuating element 33.

**[0103]** The first actuating element 31 and the second actuating element 33 may each be formed in different types of actuating elements. These different types of actuating elements are described and shown in Fig. 3. The different types of actuating elements can each be received interchangeably in the respective actuating element receptacle 32, 34.

**[0104]** For example, it is conceivable that the first actuating element 31 is designed in the form of a first rocking actuator 36. It is also conceivable that the first actuating element 31 is designed in the form of a first pressing actuator 37. Furthermore, it is conceivable that the first actuating element 31 is designed in the form of a first combination actuator 38. Analogously, it is conceivable that the second actuating element 33 is designed in the form of a second pressing actuator 39, or that the second actuating element 33 is designed in the form of a second rocking actuator 40. Or that the second actuating element 33 is designed in the form of a second combination actuator 41.

**[0105]** The first rocking actuator 36 and the second rocking actuator 40 may be designed mirror-symmetrically with respect to the central housing plane 35. The first pressing actuator 37 and the second pressing actuator 39 may also be designed mirror-symmetrically with respect to the central housing plane 35. The first combination actuator 38 and the second combination actuator 41 may also be designed mirror-symmetrically with respect to the central housing plane 35.

**[0106]** For the sake of simplicity, the rocking actuator 36, 40 type, the pressing actuator 37, 39 type or the combination actuator 38, 41 type are described in general below, it being within the ability of a person skilled in the art or clear to a person skilled in the art that, in accordance with the mirror symmetry, the respective structural configurations can each be provided for the first actuating element 31 and for the second actuating element 33.

**[0107]** In a configuration such as that shown in Figs. 3 and 4, the lighting assembly 10 is equipped with a first rocking actuator 36 in the first actuating element receptacle 32 and is equipped with a second pressing actuator 39 in the second actuating element receptacle 34. Such a configuration may be chosen for example for right-handed users. In particular, it may be provided here that the second pressing actuator 39 is pushed forward in the longitudinal direction 11 with the user's right index finger, as a result of which the second pressing actuator 39 is slid relative to the housing cover 14, whereby a second force transmission element 42 can be pressed in the transverse direction 28 to the second switch 30 and thus the light source 24 can be activated by means of the second switch 30.

**[0108]** In the configuration shown, the first actuating element 31 is designed as a first rocking actuator 36, wherein, by pressing the first rocking actuator 36 while applying force in the transverse direction 28, the first rocking actuator 36 can be pivoted about a first vertical axis 44, whereby a first force transmission element 43 can be pressed in the transverse direction 28 against the first switch 29 and thus the first switch 29 can be actuated and thus the light source 24 can be

activated.

5 [0109] In a further configuration, it is also conceivable that the first actuating element 31 is designed as a first pressing actuator 37 and that the second actuating element 33 is designed as a second rocking actuator 40. Such a configuration may be used in particular for left-handed users. In particular, it may be provided here that the first pressing actuator 37 is pushed forward in the longitudinal direction 11 with the user's left index finger, as a result of which the first pressing actuator 37 is slid relative to the housing cover 14, as a result of which a first force transmission element 43 can be pressed in the transverse direction 28 to the first switch 29 and thus the light source 24 can be activated by means of the first switch 29. In this further configuration, the second actuating element 33 may be designed as a second rocking actuator 40, wherein, by pressing the second rocking actuator 40 while applying force in the transverse direction 28, the second rocking actuator 40 can be pivoted about a second vertical axis 45, whereby a second force transmission element 42 can be pressed in the transverse direction 28 against the second switch 30 and thus the second switch 30 can be actuated and thus the light source 24 can be activated.

[0110] Due to the interchangeability of the first actuating element 31 and the second actuating element 33, the lighting assembly 10 can be easily adapted to the user in order to be able to be operated by him as easily as possible.

15 [0111] As can also be seen from Figs. 3 and 4, it may be provided that a return spring channel 46 is formed in the housing cover 14 and can extend through the housing cover 14 in the transverse direction 28. In particular, it may be provided that the return spring channel 46 extends from the first actuating element receptacle 32 to the second actuating element receptacle 34. A transverse return spring 47, which may be in engagement with the first actuating element 31 and with the second actuating element 33, may be received in the return spring channel 46. The transverse return spring 47 may have a meandering structure.

20 [0112] The return spring channel 46 may have a return spring channel width 48 and a return spring channel height 49. The return spring channel width 48 and the return spring channel height 49 are preferably chosen such that the transverse return spring 47 is received in the return spring channel 46 in such a way that it can be slid in the transverse direction 28 while at the same time minimizing the amount of play of the transverse return spring 47. In other words, the dimensioning of the return spring channel 46 can be adapted to the dimensioning of the transverse return spring 47.

25 [0113] Furthermore, it may be provided that a first unlocking clearance 50 opens into the return spring channel 46 in such a way that the transverse return spring 47 can be slid by means of a tool from the outside through the first unlocking clearance 50 in the transverse direction 28 in order to optionally be able to disengage it from the first actuating element 31 or the second actuating element 33. As a result, the actuating elements 33 can be changed.

30 [0114] In an exemplary embodiment that is not shown, such an unlocking clearance 50 may be arranged centrally in the housing cover 14.

[0115] In a further exemplary embodiment, as shown in Fig. 3 or Fig. 4, it may be provided that along with the first unlocking clearance 50 a second unlocking clearance 51 is provided, which is arranged at a distance from the first unlocking clearance 50 in the transverse direction 28. In particular, it may be provided that the first unlocking clearance 50 and the second unlocking clearance 51 are formed or arranged symmetrically with respect to the central housing plane 35.

35 [0116] Furthermore, it may be provided that a protective cover 52 is formed, which is used for closing the unlocking clearance 50, 51 in order to prevent dirt from penetrating into the return spring channel 46. Furthermore, it may also be provided that, when the firearm 1 and the lighting assembly 10 are in the assembled state, the protective cover 52 rests against a component of the firearm 1, in particular a trigger guard, and has a damping effect.

40 [0117] The function or the structure of a pressing actuator 37, 39 is described with reference to the second pressing actuator 39 shown in Figs. 3 and 4.

[0118] As can be seen particularly well from Fig. 4, it may be provided that the second pressing actuator 39 has a first clearance 53 on its side facing the housing cover 14. The first clearance 53 may have a longitudinal extent 54. The transverse return spring 47 may have a longitudinal extent 55. The longitudinal extent 54 of the first clearance 53 is preferably chosen to be so large or so much larger than a longitudinal extent 55 of the transverse return spring 47 that the second pressing actuator 39 can be slid in the longitudinal direction 11 relative to the housing cover 14. Here, the first clearance 53 can be slid in the longitudinal direction 11 relative to the transverse return spring 47. A front wall 56 of the first clearance 53 can be used here as a stop, which corresponds to the transverse return spring 47 and is used as a anti loss protection device for the second pressing actuator 39.

50 [0119] Furthermore, it may be provided that a depression 57 is formed in the second pressing actuator 39 on the side facing the housing cover 14. The depression 57 may have a depression ramp 58, wherein the depression ramp 58 can be arranged at a ramp angle 59 to the longitudinal direction 11. By providing the depression ramp 58 at the ramp angle 59, the sliding of the second pressing actuator 39 in the longitudinal direction 11 can be converted into a sliding of the second force transmission element 42 in the transverse direction 28. In this case, the second force transmission element 42 can lie against the depression ramp 58 and can be correspondingly moved by the depression ramp 58 when it is slid.

55 [0120] In particular, it may be provided that the second pressing actuator 39 is slidable in the longitudinal direction 11 between a front position 60 and a rear position 61. In the rear position 61 of the second pressing actuator 39, the second switch 30 may be unactuated. In this case, the front wall 56 of the first clearance 53 can lie against the transverse return

spring 47 and thus limit the movement of the second pressing actuator 39.

**[0121]** In particular, it may be provided that a first longitudinal return spring 62 is provided, by means of which the second pressing actuator 39 is urged into its rear position 61 or is pretensioned in this position. The first longitudinal return spring 62 may be designed in the form of a compression spring, wherein the first longitudinal return spring 62 is further compressed when the second pressing actuator 39 is slid from the rear position 61 in the direction of the front position 60. Of course, further longitudinal return springs may also be provided in order to achieve an even distribution of force or to influence the course of force over the path.

**[0122]** For the slidable guidance of the second pressing actuator 39 it may be provided that a front guiding clearance 63 is formed in the actuating element receptacle 32, 34. The front guiding clearance 63 can have a guiding clearance base 64. The guiding clearance base 64 may delimit the guiding clearance 63 on a front side. In particular, it may be provided that the front guiding clearance 63 extends in the longitudinal direction 11. The front guiding clearance 63 may be designed in the form of a groove-shaped depression.

**[0123]** It may also be provided that the second pressing actuator 39 has a front guiding lug 65, which protrudes into the front guiding clearance 63 or is slidably received in it in order to guide the second pressing actuator 39 in a slidable manner in the longitudinal direction 11.

**[0124]** It may also be provided that a lower guiding clearance 66 is formed in the actuating element receptacle 32, 34. Furthermore, it may be provided that a lower guiding lug 67 is formed on the second pressing actuator 39 and engages in the lower guiding clearance 66.

**[0125]** The front guiding lug 65 and the lower guiding lug 67 may be arranged at a distance from one another in the longitudinal direction 11. In particular, it may be provided that the depression 57 is arranged in the longitudinal direction 11 between the front guiding lug 65 and the lower guiding lug 67.

**[0126]** The first clearance 53 may also be arranged between the front guiding lug 65 and the lower guiding lug 67. The second pressing actuator 39 may be slidable in the longitudinal direction 11 and guided in the transverse direction 28 by means of the front guiding lug 65 and the lower guiding lug 67.

**[0127]** A function of the rocking actuator 36, 40 is described with reference to the first rocking actuator 36 shown in Figs. 3 and 4.

**[0128]** As can be seen from Figs. 3 and 4, it may be provided that the first rocking actuator 36 has a pivot bearing section 68, which can be received in the front guiding clearance 63. The pivot bearing section 68 may have a rounding here which corresponds to a rounding of the guiding clearance base 64, so that a plain bearing can be formed by the pivot bearing section 68 and the guiding clearance base 64. In particular, it can be achieved by means of the pivot bearing section 68 that the first rocking actuator 36 is received in the first actuating element receptacle 32 such that it can be pivoted about the vertical axis 44. The vertical axis 44 or the pivot axis of the first rocking actuator 36 may be concentric here with the rounding of the pivot bearing section 68.

**[0129]** Furthermore, it may be provided that the front guiding clearance 63 has an inner guiding clearance wall 69 and an outer guiding clearance wall 70. The outer guiding clearance wall 70 or the pivot bearing section 68 may be designed in such a way that, when the first rocking actuator 36 is in an open position, the pivot bearing section 68 lies against the outer guiding clearance 70 at a contact point 71. The contact point 71 may be arranged here at a distance from the vertical axis 44 in the longitudinal direction 11, so that the pivoting position of the first rocking actuator 36 is limited by the contact point 71. In addition, the pivoting position of the first rocking actuator 36 may be limited by a lower guiding lug 67, which may be arranged on the first rocking actuator 36 and can engage in the lower guiding clearance 66.

**[0130]** The first rocking actuator 36 can thus be received in the first actuating element receptacle 32 such that it can be pivoted about the vertical axis 44 between an outer position 72 and an inner position 73.

**[0131]** As can also be seen from Fig. 4, it may be provided that a second clearance 74, which faces the housing cover 14, is formed in the first rocking actuator 36. The second clearance 74 is used for receiving an end section of the transverse return spring 47. The first rocking actuator 36 can be secured against sliding out of the front guiding clearance 63 in the longitudinal direction 11 by the transverse return spring 47 protruding into the second clearance 74.

**[0132]** As can be seen from Fig. 4, it may be provided that a depression 75, which can interact with the first force transmission element 43, is formed in the first rocking actuator 36.

**[0133]** In a position as shown in Fig. 4, the first rocking actuator 36 is in its outer position 72. If the first rocking actuator 36 is then pressed with the user's left thumb in the transverse direction 28 in the direction of its inner position 73, the first rocking actuator 36 executes a pivoting movement about the vertical axis 44 and thereby acts on the first force transmission element 43, causing it to be slid in the transverse direction 28 to the first switch 29 and thus to actuate it. The transverse return spring 47 is thereby compressed. If the first rocking actuator 36 is then released again, it returns to its outer position 72 by the spring force of the transverse return spring 47 and is held there.

**[0134]** As can also be seen from Fig. 4, it may be provided that the housing cover 14 has a first clearance 76 in the area of the first force transmission element 43 and has a second clearance 77 in the area of the second force transmission element 42. The clearances 76, 77 in the housing cover 14 may each be closed by means of an independent sealing element 78 or by means of a common sealing element 78.

**[0135]** Furthermore, it may be provided that the force transmission element 42, 43 is designed in the form of a sphere, which is received in the sealing element 78. The provision of the sealing element 78 allows an inner side 79 of the sealing element 78 or of the housing 12 to be sealed off from an outer side 80 of the sealing element 78 or of the housing 12. In particular, electronic components that are arranged within the inner side 79 of the sealing element 78 can be shielded from environmental influences.

**[0136]** In a first exemplary embodiment, as can be seen in Fig. 4, it may be provided that the sealing element 78 is injection-moulded directly in the housing cover 14. In an alternative embodiment variant it may be provided that the sealing element 78 is designed as a structurally independent component which is inserted in the housing cover 14. In particular, it may be provided that the sealing element 78 is formed from a silicone material. The sealing element may be designed in the form of a shell and lie circumferentially against the main housing part 13.

**[0137]** As is clearly evident from Fig. 4, it may be provided that the force transmission element 42, 43 is embedded in the sealing element 78. In particular, it may be provided that the sealing element 78 encloses the force transmission element 42, 43 to such an extent that the force transmission element 42, 43 cannot fall out of the sealing element 78. In particular, it may be provided that the force transmission element 42, 43 lies directly against the actuating element 31, 33.

**[0138]** Furthermore, it may be provided that the sealing element 78 is arranged in a coverage area 81 between the force transmission element 42, 43 and the switch 29, 30.

**[0139]** As can also be seen from Fig. 3, it may be provided that a horizontal guiding lug 83 is formed in the actuating element receptacle 32, 34. The horizontal guiding lug 83 may correspond to a horizontal guiding clearance 84 in the actuating element 31, 33 and thus form a further linear guide, in particular a horizontal guide for the actuating element 31, 33.

**[0140]** Fig. 5 shows a further embodiment of the lighting assembly 10, which may be independent in itself, with the same reference numerals or component designations as in the preceding Figures 1 to 4 being used again for the same parts. In order to avoid unnecessary repetitions, reference is made to the detailed description in the preceding Figures 1 to 4.

**[0141]** As indicated in Fig. 5, it may be provided that an overall length 82 of the actuating element 31, 32 can be configured in different sizes or that different actuating elements 31, 33 with different overall lengths 82 can be made available. Thus, by changing the actuating element 31, 33 or by inserting the desired actuating element 31, 33, the lighting assembly 10 can be adapted to different users.

**[0142]** Fig. 6 shows a further embodiment of the first actuating element 31, which may be independent in itself, with the same reference numerals or component designations as in the preceding Figures 1 to 5 being used again for the same parts. In order to avoid unnecessary repetitions, reference is made to the detailed description in the preceding Figures 1 to 5.

**[0143]** In Fig. 6, the first actuating element 31 is shown in a side view.

**[0144]** As can be seen from Fig. 6, it may be provided that the first actuating element 31 is formed symmetrically about a horizontal central plane 85 and can therefore be used both on the first actuating element receptacle 32 and on the second actuating element receptacle 34. Such a symmetrical design is shown in Fig. 6 by way of example with reference to the first rocking actuator 36. All other types of actuating elements 31, 33 can also have such a symmetrical shape in order to be able to be used both on the first actuating element receptacle 32 and on the second actuating element receptacle 34.

**[0145]** Fig. 7 shows a further embodiment of the lighting assembly 10, which may be independent in itself, with the same reference numerals or component designations as in the preceding Figures 1 to 6 being used again for the same parts. In order to avoid unnecessary repetitions, reference is made to the detailed description in the preceding Figures 1 to 6.

**[0146]** In Fig. 7, the lighting assembly 10 is shown in a sectional representation according to the section line VII-VII from Fig. 3, it being expressly pointed out at this stage that the section line in Fig. 3 serves only for the purpose of indicating the position of the section, but different exemplary embodiments are shown in Figures 3 and 7.

**[0147]** As can be seen from Fig. 7, it may be provided that an outer guiding surface 86 of the lower guiding clearance 66 is designed in such a way that it is at a varying distance 87 from the central housing plane 35 over the longitudinal direction 11. This measure makes it possible that, when the actuating element 31, 33 is slid in the longitudinal direction 11, the actuating element 31, 33 is simultaneously slid in the transverse direction 28. This measure makes it possible to obtain a combination actuator 38, 41, which can act both as a pressing actuator and as a rocking actuator.

**[0148]** Fig. 8 shows a further embodiment of the housing cover 14, which may be independent in itself, with the same reference numerals or component designations as in the preceding Figures 1 to 7 being used again for the same parts. In order to avoid unnecessary repetitions, reference is made to the detailed description in the preceding Figures 1 to 7.

**[0149]** It can be seen particularly well in Fig. 8 that the sealing element 78 can be designed in the shape of a shell. In particular, the sealing element 78 may be formed on the inside of the housing cover 14. This can be achieved for example due to the fact that the elastic material of the sealing element 78 can have been injection-moulded directly into the comparatively stable material of the housing cover 14. Of course, the sealing element 78 may also have been produced in a separate production step and have a shape that is adapted to the housing cover 14.

**[0150]** The second clearance 77 in the housing cover 14 is also clearly visible in Fig. 8. In addition, in Fig. 8 the force transmission elements 43, 44 are shown removed from a force transmission element receptacle 88 in the exploded

representation. In particular, a receiving space of the second force transmission element receptacle 88 is thus visible.

[0151] As can also be seen from Fig. 8, it may be provided that the sealing element 78 has a sealing flange 89. The sealing flange 89 may be used to lie against the main housing part 13. In particular, it may be provided that the sealing flange 89 is clamped between the housing cover 14 and the main housing part 13.

[0152] In particular, it may be provided that a sealing flange receptacle 90, which is used at least for partially receiving the sealing flange 89, is formed in the housing cover 14.

[0153] As can be seen from Fig. 8, it may be provided that fastening means 91, which are used for connecting the housing cover 14 to the main housing part 13, are formed. In particular, the fastening means 91 may be designed in the form of fastening screws.

[0154] The exemplary embodiments are shown with reference to a pistol; the lighting assembly according to the invention may of course also be connected to another type of firearm, in particular a rifle, carbine, submachine gun, shotgun, etc.

[0155] The exemplary embodiments show possible embodiment variants, it being noted at this stage that the invention is not restricted to the embodiment variants thereof specifically represented, but rather that various combinations of the individual embodiment variants with one another are also possible and, on the basis of the teaching for technical action provided by the present invention, this possibility of variation is within the ability of a person skilled in the art working in this technical field.

[0156] The scope of protection is determined by the claims. However, the description and the drawings should be used to interpret the claims. Individual features or combinations of features from the different exemplary embodiments shown and described can represent independent inventive solutions per se. The object on which the independent inventive solutions are based can be found in the description.

[0157] All of the indications of ranges of values in the present description should be understood as meaning that they include any and all subranges thereof; for example, the indication 1 to 10 should be understood as meaning that all of the subranges on the basis of the lower limit 1 and the upper limit 10 are included, i.e. all of the subranges begin with a lower limit of 1 or greater and end with an upper limit of 10 or less, for example 1 to 1.7, or 3.2 to 8.1, or 5.5 to 10.

[0158] For the sake of good order, it should finally be pointed out that, for better understanding of the construction, elements have sometimes been represented not to scale and/or enlarged and/or reduced in size.

List of reference numerals

30		30	Second switch
	1	31	First actuating element
	2	32	First actuating element receptacle
	3	33	Second actuating element
35	4	34	Second actuating element receptacle
	5	35	Central housing plane
	6	36	First rocking actuator
	7	37	First pressing actuator
	8	38	First combination actuator
40	9	39	Second pressing actuator
	10	40	Second rocking actuator
	11	41	Second combination actuator
	12	42	Second force transmission element
45	13	43	First force transmission element
	14	44	First vertical axis
	15	45	Second vertical axis
	16	46	Return spring channel
	17	47	Transverse return spring
50	18	48	Return spring channel width
	19	49	Return spring channel height
	20	50	First unlocking clearance
	21	51	Second unlocking clearance
55	22	52	Protective cover
	23	53	First clearance
	24	54	Longitudinal extent of first clearance

## EP 4 357 722 B1

(continued)

25	Contact	55	Longitudinal extent of transverse return spring	
26	Sealing ring			
5	27	Securing element receptacle	56	Front wall of first clearance
	28	Transverse direction	57	Depression
	29	First switch	58	Depression ramp
	59	Ramp angle		
	60	Front position		
10	61	Rear position		
	62	First longitudinal return spring		
	63	Front guiding clearance		
	64	Guiding clearance base		
15	65	Front guiding lug		
	66	Lower guiding clearance		
	67	Lower guiding lug		
	68	Pivot bearing section		
	69	Inner guiding clearance wall		
20	70	Outer guiding clearance wall		
	71	Contact point		
	72	Outer position		
	73	Inner position		
25	74	Second clearance		
	75	Depression		
	76	First clearance of housing cover		
	77	Second clearance of housing cover		
	78	Sealing element		
30	79	Inner side		
	80	Outer side		
	81	Coverage area		
	82	Overall length		
35	83	Horizontal guiding lug		
	84	Horizontal guiding clearance		
	85	Horizontal central plane		
	86	Outer guiding surface		
	87	Distance		
40	88	Force transmission element receptacle		
	89	Sealing flange		
	90	Sealing flange receptacle		
	91	Fastening means		

45

### Claims

1. Lighting assembly (10) for a firearm (1), the lighting assembly (10) comprising:

50

- a housing (12) with an interior (23) for receiving electronic components, wherein the housing (12) extends in a longitudinal direction (11);

- a light source (24), wherein the light source (24) is received in the interior (23) of the housing (12);

- a first switch (29), which is used for switching the light source (24), wherein the first switch (29) is received in the interior (23) of the housing (12);

55

- a first actuating element receptacle (32) for receiving a first actuating element (31), which is used for actuating the first switch (29),

wherein the first actuating element receptacle (32) is arranged at a first position of the housing (12),

whereby the first actuating element receptacle (32) is designed in such a way that the first actuating element (31) in the form of a first pressing actuator (37) can be received in the first actuating element receptacle (32), wherein the first pressing actuator (37) can be slid along a linear direction, in particular along the longitudinal direction (11), relative to the housing (12), and wherein the first switch (29) can be actuated by the sliding in the linear direction of the first pressing actuator (37) relative to the housing (12)

and in that the first actuating element (31) in the form of a first rocking actuator (36) can be received in the first actuating element receptacle (32), wherein the first rocking actuator (36) can be pivoted about a first pivot axis, in particular about a first vertical axis (44), relative to the housing (12), and wherein the first switch (29) can be actuated by the pivoting of the first rocking actuator (36) relative to the housing (12).

2. Lighting assembly (10) according to Claim 1, **characterized in that** the following components are formed:

- a second switch (30), which is used for switching the light source (24), wherein the second switch (30) is received in the interior (23) of the housing (12);

- a second actuating element receptacle (34) for receiving a second actuating element (33), which is used for actuating the second switch (30),

wherein the second actuating element receptacle (34) is designed in such a way that the second actuating element (33) in the form of a second pressing actuator (39) can be received in the second actuating element receptacle (34), wherein the second pressing actuator (39) can be slid along a linear direction, in particular along the longitudinal direction (11), relative to the housing (12), and wherein the second switch (30) can be actuated by the sliding in the linear direction of the second pressing actuator (39) relative to the housing (12)

and wherein the second actuating element (33) in the form of a second rocking actuator (40) can be received in the second actuating element receptacle (34), wherein the second rocking actuator (40) can be pivoted about a second vertical axis (45) relative to the housing (12), and wherein the second switch (30) can be actuated by the pivoting of the second rocking actuator (40) relative to the housing (12).

3. Lighting assembly (10) according to Claim 2, **characterized in that** the first actuating element receptacle (32) is arranged on a left side of the housing (12) with respect to the longitudinal direction (11) and the second actuating element receptacle (34) is arranged on a right side of the housing (12) with respect to the longitudinal direction (11).

4. Lighting assembly (10) according to one of Claims 1 to 3, **characterized in that** the first actuating element (31) is designed in the form of a first combination actuator (38) with pressing functionality and rocking functionality.

5. Lighting assembly (10) according to one of the preceding claims, **characterized in that** a transverse return spring (47) is formed, wherein the transverse return spring (47) is received in a return spring channel (46) in such a way as to be guided transversely in the housing (12) and acts on the first actuating element (31).

6. Lighting assembly (10) according to Claim 5, **characterized in that** an unlocking clearance (50), which opens into the return spring channel (46), is formed in the housing (12), wherein the transverse return spring (47) located in the return spring channel (46) is accessible through the unlocking clearance (50) and, by using a tool, can be disengaged from the first actuating element (31).

7. Lighting assembly (10) according to Claim 6, **characterized in that** a protective cover (52), which closes the unlocking clearance (50), is formed.

8. Lighting assembly (10) according to one of Claims 5 to 7, **characterized in that** the transverse return spring (47) acts at the same time as a anti loss protection device for when the first actuating element (31) is received in the first actuating element receptacle (32).

9. Lighting assembly (10) according to one of Claims 5 to 8, **characterized in that**, in the case of the first actuating element (31) if it is designed in the form of the first pressing actuator (37), a first clearance (53) is formed, which has a longitudinal extent (54) in the longitudinal direction (11), wherein the longitudinal extent (54) of the first clearance (53) in the longitudinal direction (11) is greater than a longitudinal extent (55) of the transverse return spring (47) in the longitudinal direction (11), wherein the first clearance (53) together with the transverse return spring (47) are used as an axial stop for limiting the axial sliding of the first pressing actuator (37) along the longitudinal direction (11) relative to the housing (12).

10. Lighting assembly (10) according to one of Claims 1 to 9, **characterized in that**, in the case of the first actuating

element (31) if it is designed in the form of the first pressing actuator (37), a depression (57) with a depression ramp (58) is formed, wherein the depression ramp (58) is formed at a ramp angle (59) to the longitudinal direction (11).

5 11. Lighting assembly (10) according to one of Claims 1 to 10, **characterized in that**, in the case of the first actuating element (31) if it is designed in the form of the first pressing actuator (37), a first longitudinal return spring (62) is formed.

10 12. Lighting assembly (10) according to one of Claims 2 to 11, **characterized in that** the first actuating element receptacle (32) and the second actuating element receptacle (34) are formed symmetrically with respect to a central housing plane (35) and **in that** the first actuating element (31) is formed symmetrically, at least in some sections, about a horizontal central plane (85), so that the first actuating element (31) can be optionally used in the first actuating element receptacle (32) or in the second actuating element receptacle (34).

15 13. Lighting assembly (10) according to one of Claims 1 to 12, **characterized in that** different first actuating elements (31) are formed, which have a different overall length (82) and/or different haptic characteristics and/or colour.

20 14. Lighting assembly (10) according to one of Claims 1 to 13, **characterized in that** a front guiding clearance (63) is formed in the first actuating element receptacle (32), wherein the front guiding clearance (63) extends in the longitudinal direction (11), wherein the front guiding clearance (63) has at its front end a guiding clearance base (64) with a rounding, wherein the first actuating element (31) has a pivot bearing section (68) which corresponds to the rounding of the front guiding clearance, wherein the pivot bearing section (68) forms with the guiding clearance base (64) a pivot axis about the vertical axis (44).

25 15. Lighting assembly (10) according to one of Claims 1 to 14, **characterized in that** a lower guiding clearance (66) is formed in the first actuating element receptacle (32), wherein the first actuating element (31) has a lower guiding lug (67), which corresponds to the lower guiding clearance (66).

30 16. Lighting assembly (10) according to Claim 15, **characterized in that** the lower guiding clearance (66) has an outer guiding surface (86) facing a central housing plane (35), wherein the outer guiding surface (86) is at a varying distance (87) from the central housing plane (35) when viewed in the longitudinal direction (11).

17. Firearm (1) comprising:

35 - a lighting assembly (10), which is received on the firearm (1), or is at least partially integrally formed on the firearm,

**characterized in that**

the lighting assembly (10) is designed according to one of the preceding claims.

40 18. Firearm (1) according to Claim 17, **characterized in that** a mounting rail, preferably a mounting rail of a frame (5), is formed, wherein the lighting assembly (10) is removably received on the mounting rail.

45 19. Actuating element (31, 33) for a lighting assembly (10), **characterized in that** the actuating element (31, 33) is designed to be incorporated in the actuation element receptacle of a lighting assembly according to any one of Claims 1 to 16.

**Patentansprüche**

50 1. Beleuchtungsbaugruppe (10) für eine Handfeuerwaffe (1), die Beleuchtungsbaugruppe (10) umfassend:

- ein Gehäuse (12) mit einem Innenraum (23) zur Aufnahme elektronischer Bauteile, wobei sich das Gehäuse (12) in einer Längsrichtung (11) erstreckt;
- eine Lichtquelle (24), wobei die Lichtquelle (24) im Innenraum (23) des Gehäuses (12) aufgenommen ist;
- einen ersten Schalter (29), welcher zum Schalten der Lichtquelle (24) dient, wobei der erste Schalter (29) im Innenraum (23) des Gehäuses (12) aufgenommen ist;
- eine erste Betätigungselementaufnahme (32) zur Aufnahme eines ersten Betätigungselementes (31), welches zum Betätigen des ersten Schalters (29) dient, wobei die erste Betätigungselementaufnahme (32) an einer

ersten Position des Gehäuses (12) angeordnet ist,  
wobei die erste Betätigungselementaufnahme (32) derart ausgebildet ist, dass in der ersten Betätigungselementaufnahme (32) das erste Betätigungselement (31) in Form eines ersten Drückaktuators (37) aufnehmbar ist, wobei der erste Drückaktor (37) entlang einer Linearrichtung, insbesondere entlang der Längsrichtung (11), relativ zum Gehäuse (12) verschiebbar ist, und wobei durch die Verschiebung in Linearrichtung des ersten Drückaktuators (37) relativ zum Gehäuse (12) der erste Schalter (29) betätigbar ist  
und dass in der ersten Betätigungselementaufnahme (32) das erste Betätigungselement (31) in Form eines ersten Wippaktuators (36) aufnehmbar ist, wobei der erste Wippaktor (36) um eine erste Schwenkachse, insbesondere um eine erste Hochachse (44), relativ zum Gehäuse (12) verschwenkbar ist, und wobei durch die Verschwenkung des ersten Wippaktuators (36) relativ zum Gehäuse (12) der erste Schalter (29) betätigbar ist.

2. Beleuchtungsbaugruppe (10) nach Anspruch 1, **dadurch gekennzeichnet, dass** folgende Bauteile ausgebildet sind:

- ein zweiter Schalter (30), welcher zum Schalten der Lichtquelle (24) dient, wobei der zweite Schalter (30) im Innenraum (23) des Gehäuses (12) aufgenommen ist;  
- eine zweite Betätigungselementaufnahme (34) zur Aufnahme eines zweiten Betätigungselementes (33), welches zum Betätigen des zweiten Schalters (30) dient,  
wobei die zweite Betätigungselementaufnahme (34) derart ausgebildet ist, dass in der zweiten Betätigungselementaufnahme (34) das zweite Betätigungselement (33) in Form eines zweiten Drückaktuators (39) aufnehmbar ist, wobei der zweite Drückaktor (39) entlang einer Linearrichtung, insbesondere entlang der Längsrichtung (11), relativ zum Gehäuse (12) verschiebbar ist, und wobei durch die Verschiebung in Linearrichtung des zweiten Drückaktuators (39) relativ zum Gehäuse (12) der zweite Schalter (30) betätigbar ist  
und wobei in der zweiten Betätigungselementaufnahme (34) das zweite Betätigungselement (33) in Form eines zweiten Wippaktuators (40) aufnehmbar ist, wobei der zweite Wippaktor (40) um eine zweite Hochachse (45) relativ zum Gehäuse (12) verschwenkbar ist, und wobei durch die Verschwenkung des zweiten Wippaktuators (40) relativ zum Gehäuse (12) der zweite Schalter (30) betätigbar ist.

3. Beleuchtungsbaugruppe (10) nach Anspruch 2, **dadurch gekennzeichnet, dass** die erste Betätigungselementaufnahme (32) bezüglich der Längsrichtung (11) an einer linken Seite des Gehäuses (12) angeordnet ist und die zweite Betätigungselementaufnahme (34) bezüglich der Längsrichtung (11) an einer rechten Seite des Gehäuses (12) angeordnet ist.

4. Beleuchtungsbaugruppe (10) nach einem der Ansprüche 1 bis 3, **dadurch gekennzeichnet, dass** das erste Betätigungselement (31) in Form eines ersten Kombiaktuators (38) mit Drückfunktionalität und Wippfunktionalität ausgebildet ist.

5. Beleuchtungsbaugruppe (10) nach einem der vorhergehenden Ansprüche, **dadurch gekennzeichnet, dass** eine Querrückstellfeder (47) ausgebildet ist, wobei die Querrückstellfeder (47) in einem Rückstellfederkanal (46) quer im Gehäuse (12) geführt aufgenommen ist und auf das erste Betätigungselement (31) wirkt.

6. Beleuchtungsbaugruppe (10) nach Anspruch 5, **dadurch gekennzeichnet, dass** im Gehäuse (12) eine Entriegelungsausnehmung (50) ausgebildet ist, welche in den Rückstellfederkanal (46) mündet, wobei die in dem Rückstellfederkanal (46) befindliche Querrückstellfeder (47) durch die Entriegelungsausnehmung (50) hindurch zugänglich ist und mit einem Werkzeug außer Eingriff mit dem ersten Betätigungselement (31) bringbar ist.

7. Beleuchtungsbaugruppe (10) nach Anspruch 6, **dadurch gekennzeichnet, dass** eine Schutzabdeckung (52) ausgebildet ist, welche die Entriegelungsausnehmung (50) verschließt.

8. Beleuchtungsbaugruppe (10) nach einem der Ansprüche 5 bis 7, **dadurch gekennzeichnet, dass** die Querrückstellfeder (47) gleichzeitig als Verliersicherung zur Aufnahme des ersten Betätigungselementes (31) in der ersten Betätigungselementaufnahme (32) wirkt.

9. Beleuchtungsbaugruppe (10) nach einem der Ansprüche 5 bis 8, **dadurch gekennzeichnet, dass** bei dem ersten Betätigungselement (31), wenn es in Form des ersten Drückaktuators (37) ausgebildet ist, eine erste Ausnehmung (53) ausgebildet ist, welche eine Längserstreckung (54) in Längsrichtung (11) aufweist, wobei die Längserstreckung (54) der ersten Ausnehmung (53) in Längsrichtung (11) größer ist, als eine Längserstreckung (55) der Querrückstellfeder (47) in Längsrichtung (11), wobei die erste Ausnehmung (53) zusammen mit der Querrückstellfeder (47) als Axialanschlag zur Begrenzung der Axialverschiebung des ersten Drückaktuators (37) entlang der Längs-

richtung (11) relativ zum Gehäuse (12) dient.

5 **10.** Beleuchtungsbaugruppe (10) nach einem der Ansprüche 1 bis 9, **dadurch gekennzeichnet, dass** bei dem ersten Betätigungselement (31), wenn es in Form des ersten Drückaktuators (37) ausgebildet ist, eine Vertiefung (57) mit einer Vertiefungsrampe (58) ausgebildet ist, wobei die Vertiefungsrampe (58) in einem Rampenwinkel (59) zur Längsrichtung (11) ausgebildet ist.

10 **11.** Beleuchtungsbaugruppe (10) nach einem der Ansprüche 1 bis 10, **dadurch gekennzeichnet, dass** bei dem ersten Betätigungselement (31), wenn es in Form des ersten Drückaktuators (37) ausgebildet ist, eine erste Längsrückstellfeder (62) ausgebildet ist.

15 **12.** Beleuchtungsbaugruppe (10) nach einem der Ansprüche 2 bis 11, **dadurch gekennzeichnet, dass** die erste Betätigungselementaufnahme (32) und die zweite Betätigungselementaufnahme (34) bezüglich einer Gehäusemittelebene (35) symmetrisch ausgebildet sind und dass das erste Betätigungselement (31) zumindest abschnittsweise um eine horizontale Mittelebene (85) symmetrisch ausgebildet ist, sodass das erste Betätigungselement (31) wahlweise in der ersten Betätigungselementaufnahme (32) oder in der zweiten Betätigungselementaufnahme (34) einsetzbar ist.

20 **13.** Beleuchtungsbaugruppe (10) nach einem der Ansprüche 1 bis 12, **dadurch gekennzeichnet, dass** unterschiedliche erste Betätigungselemente (31) ausgebildet sind, welche eine unterschiedliche Gesamtlänge (82) und/oder haptische Ausprägung und/oder Farbe aufweisen.

25 **14.** Beleuchtungsbaugruppe (10) nach einem der Ansprüche 1 bis 13, **dadurch gekennzeichnet, dass** in der ersten Betätigungselementaufnahme (32) eine vordere Führungsausnehmung (63) ausgebildet ist, wobei sich die vordere Führungsausnehmung (63) in Längsrichtung (11) erstreckt, wobei die vordere Führungsausnehmung (63) an dessen Vorderende einen Führungsausnehmungsgrund (64) mit einer Rundung aufweist, wobei das erste Betätigungselement (31) einen Schwenklagerabschnitt (68) aufweist, welcher mit der Rundung der vorderen Führungsausnehmung korrespondiert, wobei der Schwenklagerabschnitt (68) mit dem Führungsausnehmungsgrund (64) eine Schwenkachse um die Hochachse (44) bildet.

30 **15.** Beleuchtungsbaugruppe (10) nach einem der Ansprüche 1 bis 14, **dadurch gekennzeichnet, dass** in der ersten Betätigungselementaufnahme (32) eine untere Führungsausnehmung (66) ausgebildet ist, wobei das erste Betätigungselement (31) eine untere Führungsnase (67) aufweist, welche mit der unteren Führungsausnehmung (66) korrespondiert.

35 **16.** Beleuchtungsbaugruppe (10) nach Anspruch 15, **dadurch gekennzeichnet, dass** die untere Führungsausnehmung (66) eine einer Gehäusemittelebene (35) zugewandten Außenführungsfläche (86) aufweist, wobei die Außenführungsfläche (86) in Längsrichtung (11) gesehen einen unterschiedlichen Abstand (87) zur Gehäusemittelebene (35) aufweist.

40 **17.** Handfeuerwaffe (1) umfassend:

- eine Beleuchtungsbaugruppe (10), welche an der Handfeuerwaffe (1) aufgenommen ist, oder zumindest teilweise integral an der Handfeuerwaffe ausgebildet ist,

45 **dadurch gekennzeichnet, dass**

die Beleuchtungsbaugruppe (10) nach einem der vorhergehenden Ansprüche ausgebildet ist.

50 **18.** Handfeuerwaffe (1) nach Anspruch 17, **dadurch gekennzeichnet, dass** eine Montageschiene, bevorzugt eine Montageschiene eines Griffstücks (5), ausgebildet ist, wobei die Beleuchtungsbaugruppe (10) entfernbar an der Montageschiene aufgenommen ist.

55 **19.** Betätigungselement (31, 33) für eine Beleuchtungsbaugruppe (10), **dadurch gekennzeichnet, dass** das Betätigungselement (31, 33) dazu ausgebildet ist, in die Betätigungselementaufnahme einer Beleuchtungsbaugruppe nach einem der Ansprüche 1 bis 16 eingebaut zu sein.

**Revendications**

1. Ensemble d'éclairage (10) pour une arme à feu (1), l'ensemble d'éclairage (10) comprenant :

- un boîtier (12) avec un intérieur (23) pour recevoir des composants électroniques, dans lequel le boîtier (12) s'étend dans une direction longitudinale (11) ;
- une source de lumière (24), dans lequel la source de lumière (24) est reçue dans l'intérieur (23) du boîtier (12) ;
- un premier commutateur (29), qui est utilisé pour commuter la source de lumière (24), dans lequel le premier commutateur (29) est reçu dans l'intérieur (23) du boîtier (12) ;
- un premier réceptacle d'élément d'actionnement (32) pour recevoir un premier élément d'actionnement (31), qui est utilisé pour actionner le premier commutateur (29), dans lequel le premier réceptacle d'élément d'actionnement (32) est agencé au niveau d'une première position du boîtier (12), dans lequel le premier réceptacle d'élément d'actionnement (32) est conçu de telle sorte que le premier élément d'actionnement (31) sous la forme d'un premier actionneur à pression (37) peut être reçu dans le premier réceptacle d'élément d'actionnement (32), dans lequel le premier actionneur à pression (37) peut être coulissé le long d'une direction linéaire, en particulier le long de la direction longitudinale (11), par rapport au boîtier (12), et dans lequel le premier commutateur (29) peut être actionné par le coulissement dans la direction linéaire du premier actionneur à pression (37) par rapport au boîtier (12), et en ce que le premier élément d'actionnement (31) sous la forme d'un premier actionneur basculant (36) peut être reçu dans le premier réceptacle d'élément d'actionnement (32), dans lequel le premier actionneur basculant (36) peut être pivoté autour d'un premier axe de pivotement, en particulier autour d'un premier axe vertical (44), par rapport au boîtier (12), et dans lequel le premier commutateur (29) peut être actionné par le pivotement du premier actionneur basculant (36) par rapport au boîtier (12).

2. Ensemble d'éclairage (10) selon la revendication 1, **caractérisé en ce que** les composants suivants sont formés :

- un second commutateur (30), qui est utilisé pour commuter la source de lumière (24), dans lequel le second commutateur (30) est reçu dans l'intérieur (23) du boîtier (12) ;
- un second réceptacle d'élément d'actionnement (34) pour recevoir un second élément d'actionnement (33), qui est utilisé pour actionner le second commutateur (30), dans lequel le second réceptacle d'élément d'actionnement (34) est conçu de manière à ce que le second élément d'actionnement (33) sous la forme d'un second actionneur à pression (39) puisse être reçu dans le second réceptacle d'élément d'actionnement (34), dans lequel le second actionneur à pression (39) peut être coulissé le long d'une direction linéaire, en particulier le long de la direction longitudinale (11), par rapport au boîtier (12), et dans lequel le second commutateur (30) peut être actionné par le coulissement dans la direction linéaire du second actionneur à pression (39) par rapport au boîtier (12), et dans lequel le second élément d'actionnement (33) sous la forme d'un second actionneur basculant (40) peut être reçu dans le second réceptacle d'élément d'actionnement (34), dans lequel le second actionneur basculant (40) peut être pivoté autour d'un second axe vertical (45) par rapport au boîtier (12), et dans lequel le second commutateur (30) peut être actionné par le pivotement du second actionneur basculant (40) par rapport au boîtier (12).

3. Ensemble d'éclairage (10) selon la revendication 2, **caractérisé en ce que** le premier réceptacle d'élément d'actionnement (32) est agencé sur un côté gauche du boîtier (12) par rapport à la direction longitudinale (11), et le second réceptacle d'élément d'actionnement (34) est agencé sur un côté droit du boîtier (12) par rapport à la direction longitudinale (11).

4. Ensemble d'éclairage (10) selon l'une quelconque des revendications 1 à 3, **caractérisé en ce que** le premier élément d'actionnement (31) est conçu sous la forme d'un premier actionneur de combinaison (38) avec une fonctionnalité de pression et une fonctionnalité de basculement.

5. Ensemble d'éclairage (10) selon l'une quelconque des revendications précédentes, **caractérisé en ce qu'un** ressort de rappel transversal (47) est formé, dans lequel le ressort de rappel transversal (47) est reçu dans un canal de ressort de rappel (46) de manière à être guidé transversalement dans le boîtier (12), et agit sur le premier élément d'actionnement (31).

6. Ensemble d'éclairage (10) selon la revendication 5, **caractérisé en ce qu'un** jeu de déverrouillage (50), qui s'ouvre

## EP 4 357 722 B1

dans le canal de ressort de rappel (46), est formé dans le boîtier (12), dans lequel le ressort de rappel transversal (47) situé dans le canal de ressort de rappel (46) est accessible via le jeu de déverrouillage (50) et, à l'aide d'un outil, peut être libéré du premier élément d'actionnement (31).

- 5 7. Ensemble d'éclairage (10) selon la revendication 6, **caractérisé en ce qu'**un couvercle de protection (52) est formé, qui ferme le jeu de déverrouillage (50).
- 10 8. Ensemble d'éclairage (10) selon l'une quelconque des revendications 5 à 7, **caractérisé en ce que** le ressort de rappel transversal (47) agit en même temps comme un dispositif de protection anti-perte lorsque le premier élément d'actionnement (31) est reçu dans le premier réceptacle d'élément d'actionnement (32).
- 15 9. Ensemble d'éclairage (10) selon l'une quelconque des revendications 5 à 8, **caractérisé en ce que** dans le cas du premier élément d'actionnement (31), s'il est conçu sous la forme du premier actionneur à pression (37), un premier jeu (53) est formé, qui présente une étendue longitudinale (54) dans la direction longitudinale (11), dans lequel l'étendue longitudinale (54) du premier jeu (53) dans la direction longitudinale (11) est supérieure à une étendue longitudinale (55) du ressort de rappel transversal (47) dans la direction longitudinale (11), dans lequel le premier jeu (53) ainsi que le ressort de rappel transversal (47) sont utilisés comme une butée axiale pour limiter le coulisement axial du premier actionneur à pression (37) le long de la direction longitudinale (11) par rapport au boîtier (12).
- 20 10. Ensemble d'éclairage (10) selon l'une des revendications 1 à 9, **caractérisé en ce que** dans le cas du premier élément d'actionnement (31), s'il est conçu sous la forme du premier actionneur à pression (37), un enfoncement (57) avec une rampe d'enfoncement (58) est formé, dans lequel la rampe d'enfoncement (58) est formée à un angle de rampe (59) par rapport à la direction longitudinale (11).
- 25 11. Ensemble d'éclairage (10) selon l'une quelconque des revendications 1 à 10, **caractérisé en ce que** dans le cas du premier élément d'actionnement (31) s'il est conçu sous la forme du premier actionneur à pression (37), un premier ressort de rappel longitudinal (62) est formé.
- 30 12. Ensemble d'éclairage (10) selon l'une quelconque des revendications 2 à 11, **caractérisé en ce que** le premier réceptacle d'élément d'actionnement (32) et le second réceptacle d'élément d'actionnement (34) sont formés symétriquement par rapport à un plan de boîtier central (35), et **en ce que** le premier élément d'actionnement (31) est formé symétriquement, au moins dans certaines sections, autour d'un plan central horizontal (85), de sorte que le premier élément d'actionnement (31) peut éventuellement être utilisé dans le premier réceptacle d'élément d'actionnement (32) ou dans le second réceptacle d'élément d'actionnement (34).
- 35 13. Ensemble d'éclairage (10) selon l'une quelconque des revendications 1 à 12, **caractérisé en ce que** différents premiers éléments d'actionnement (31) sont formés, qui présentent une longueur totale (82) différente et/ou des caractéristiques haptiques et/ou une couleur différentes.
- 40 14. Ensemble d'éclairage (10) selon l'une quelconque des revendications 1 à 13, **caractérisé en ce qu'**un jeu de guidage avant (63) est formé dans le premier réceptacle d'élément d'actionnement (32), dans lequel le jeu de guidage avant (63) s'étend dans la direction longitudinale (11), dans lequel le jeu de guidage avant (63) présente à son extrémité avant une base de jeu de guidage (64) avec un arrondi, dans lequel le premier élément d'actionnement (31) présente une section de palier de pivotement (68) qui correspond à l'arrondi du jeu de guidage avant, dans lequel la section de palier de pivotement (68) forme avec la base de jeu de guidage (64) un axe de pivotement autour de l'axe vertical (44).
- 45 15. Ensemble d'éclairage (10) selon l'une quelconque des revendications 1 à 14, **caractérisé en ce qu'**un jeu de guidage inférieur (66) est formé dans le premier réceptacle d'élément d'actionnement (32), dans lequel le premier élément d'actionnement (31) présente une patte de guidage inférieure (67), qui correspond au jeu de guidage inférieur (66).
- 50 16. Ensemble d'éclairage (10) selon la revendication 15, **caractérisé en ce que** le jeu de guidage inférieur (66) présente une surface de guidage extérieure (86) faisant face à un plan de boîtier central (35), dans lequel la surface de guidage extérieure (86) est à une distance variable (87) du plan de boîtier central (35) lorsqu'elle est vue dans la direction longitudinale (11).
- 55 17. Arme à feu (1), comprenant :
- un ensemble d'éclairage (10), qui est reçu sur l'arme à feu (1), ou est au moins partiellement formé d'un seul

tenant sur l'arme à feu,

**caractérisée en ce que**

l'ensemble d'éclairage (10) est conçu selon l'une quelconque des revendications précédentes.

5

**18.** Arme à feu (1) selon la revendication 17, **caractérisée en ce qu'**un rail de montage est formé, de préférence un rail de montage d'un cadre (5), dans lequel l'ensemble d'éclairage (10) est reçu de manière amovible sur le rail de montage.

10

**19.** Élément d'actionnement (31, 33) pour un ensemble d'éclairage (10), **caractérisé en ce que** l'élément d'actionnement (31, 33) est conçu pour être incorporé dans le réceptacle d'élément d'actionnement d'un ensemble d'éclairage selon l'une quelconque des revendications 1 à 16.

15

20

25

30

35

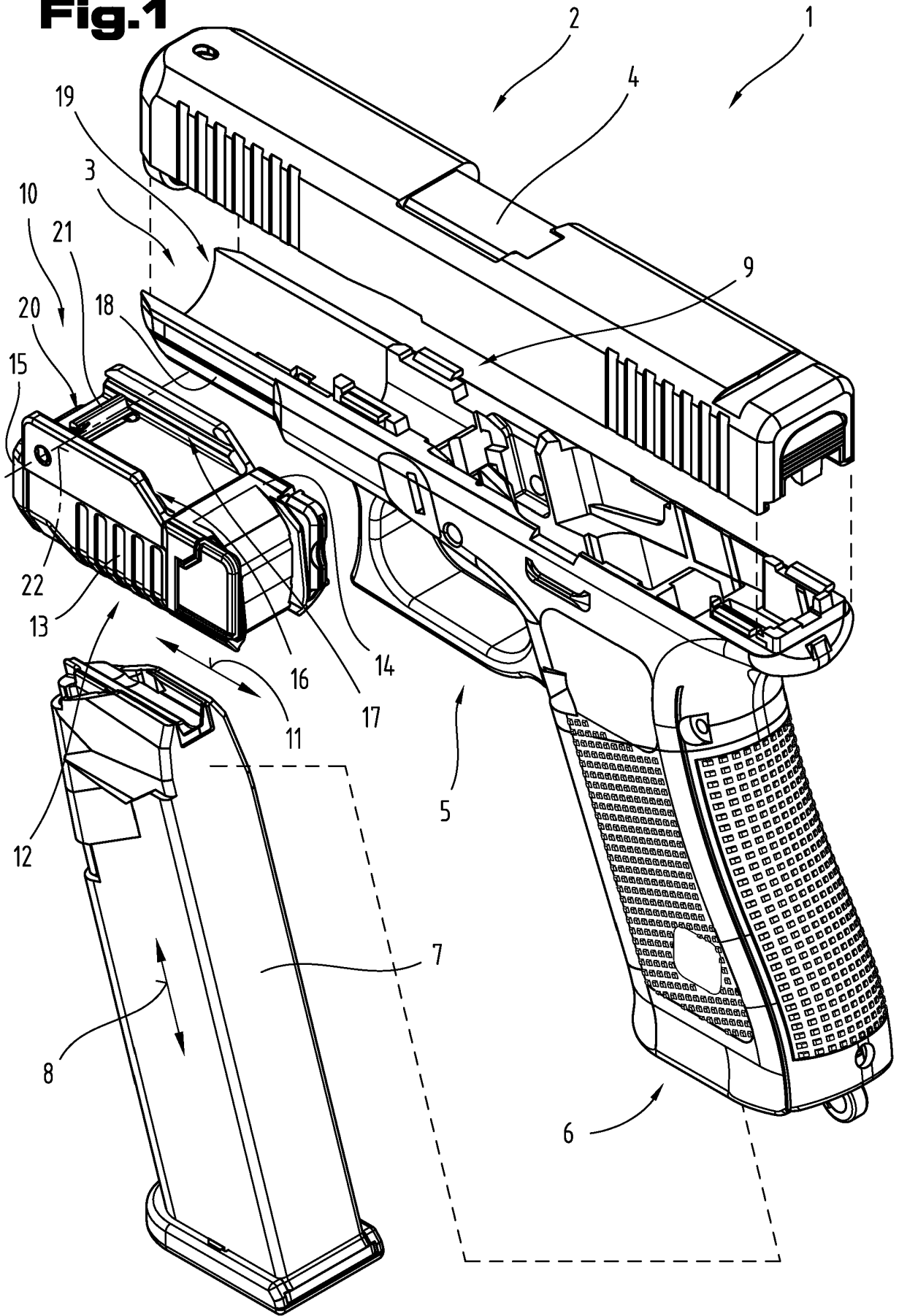
40

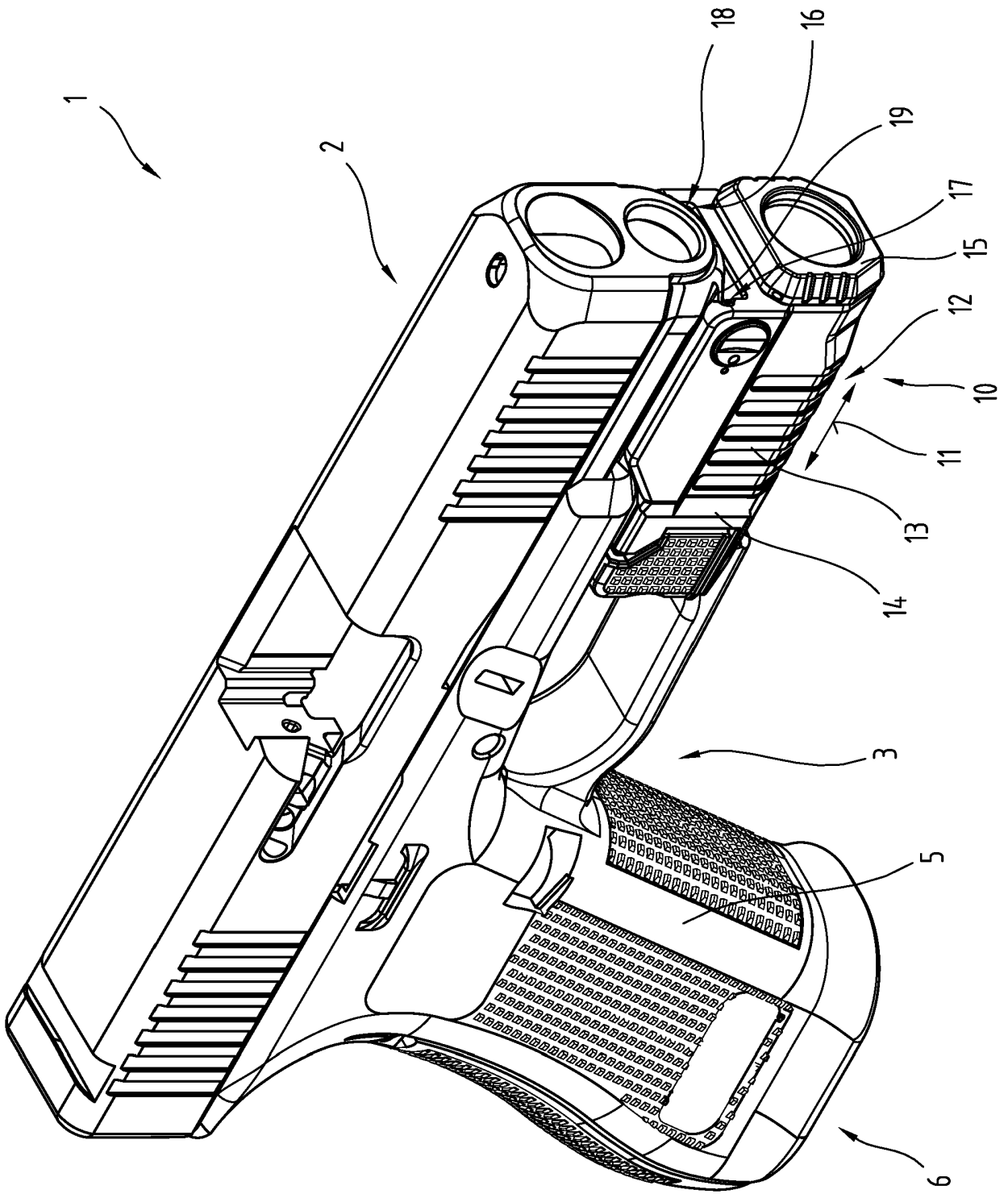
45

50

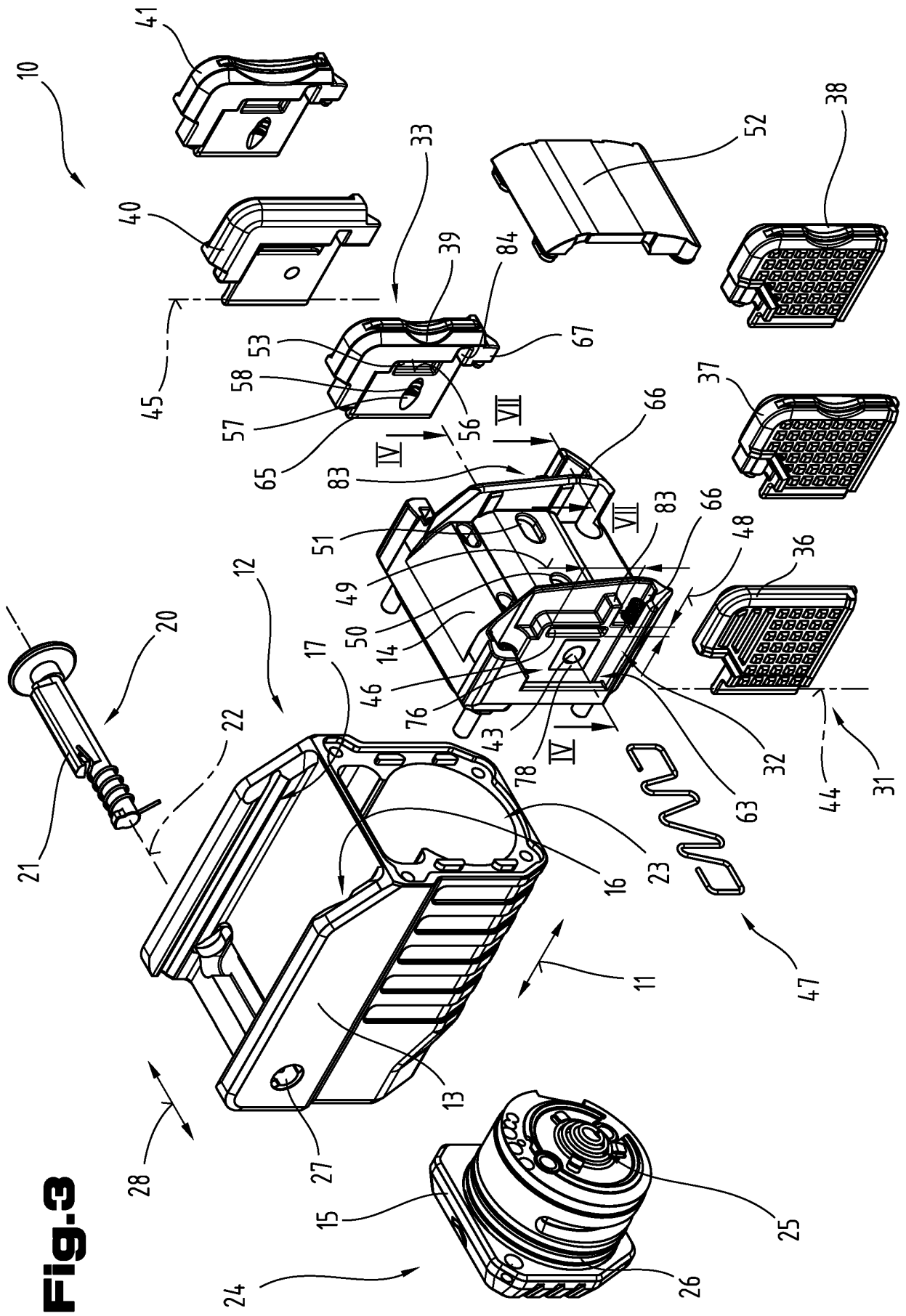
55

**Fig.1**

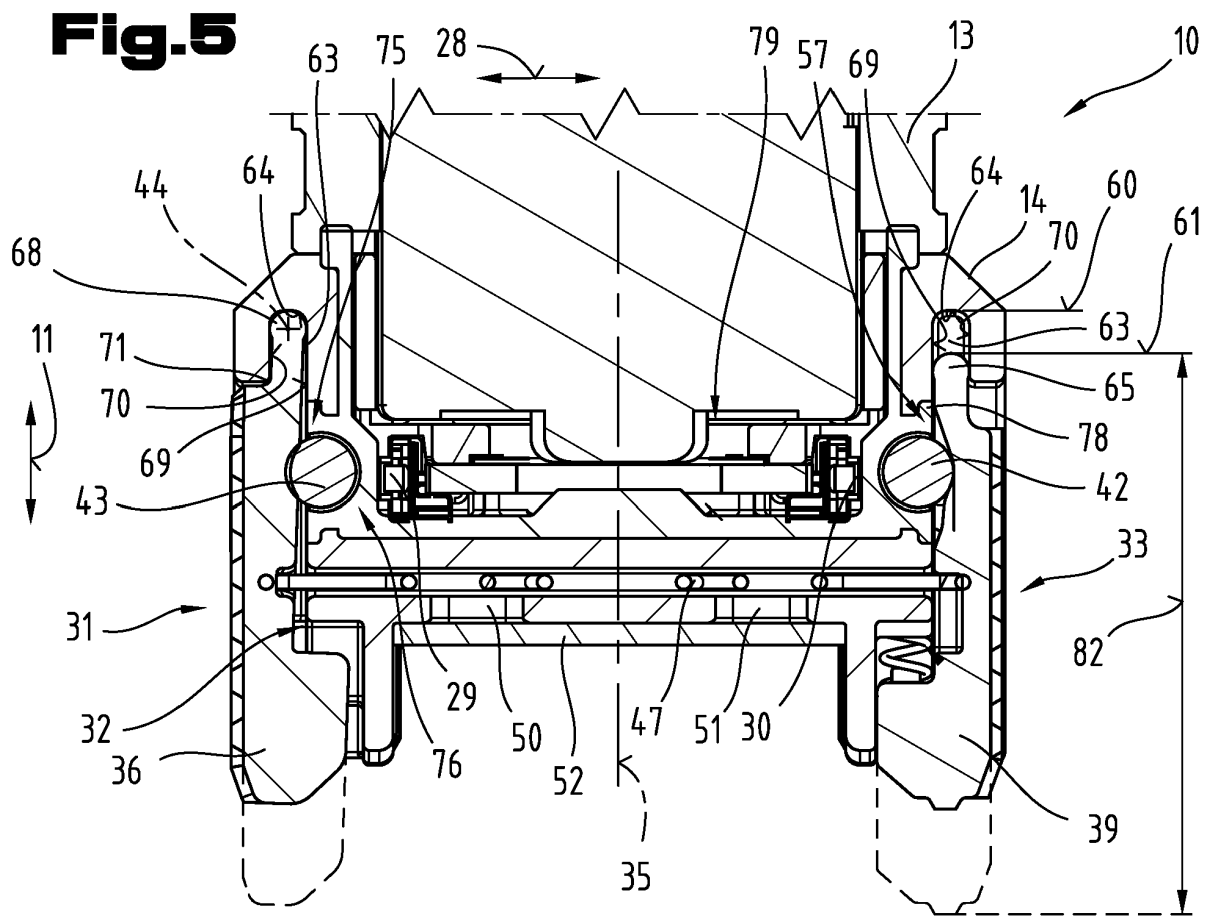
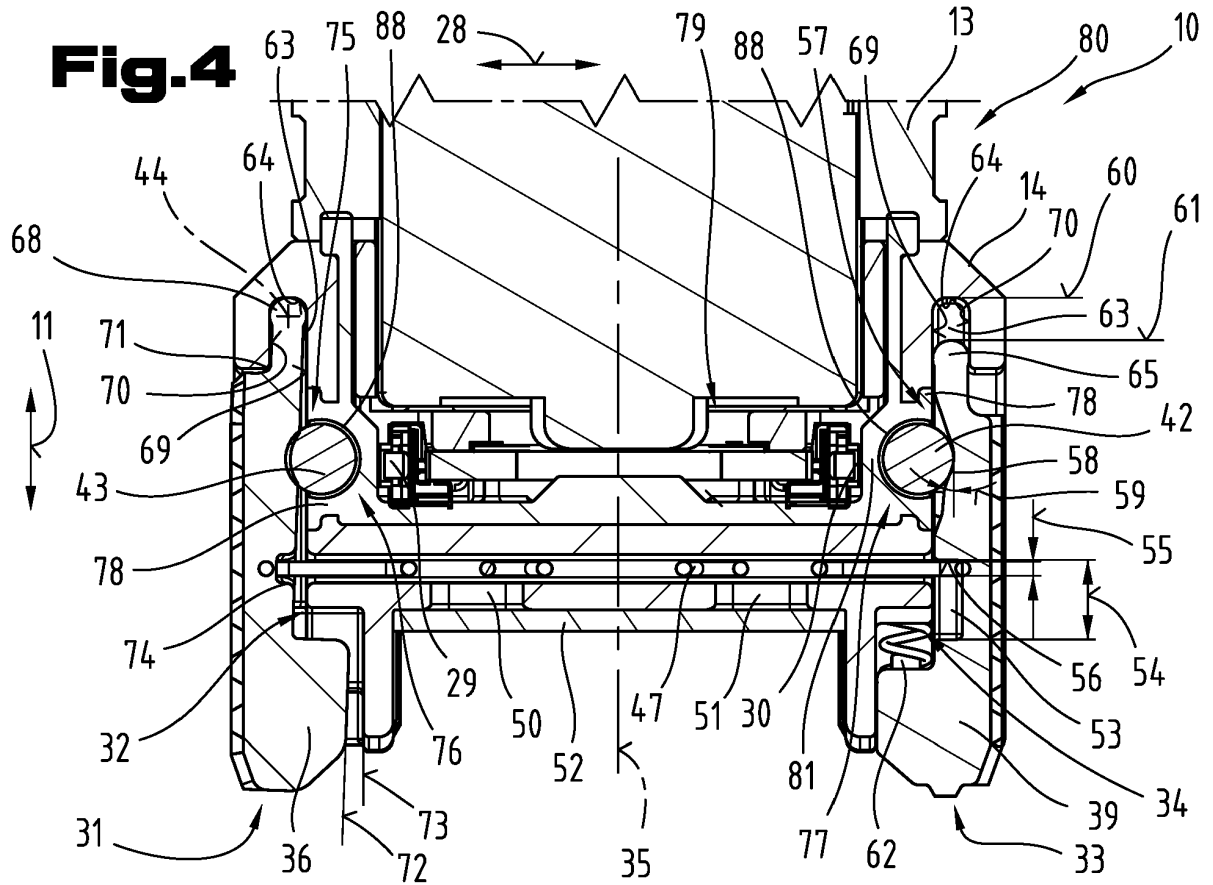




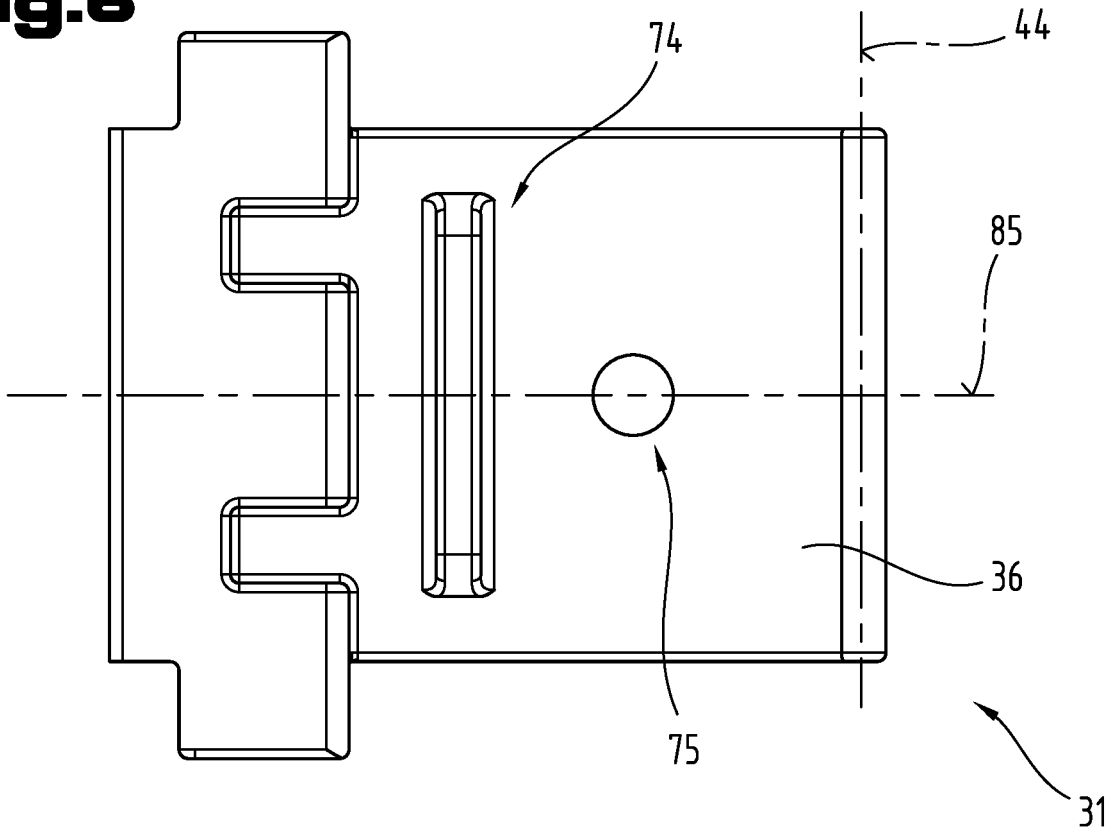
**Fig.2**



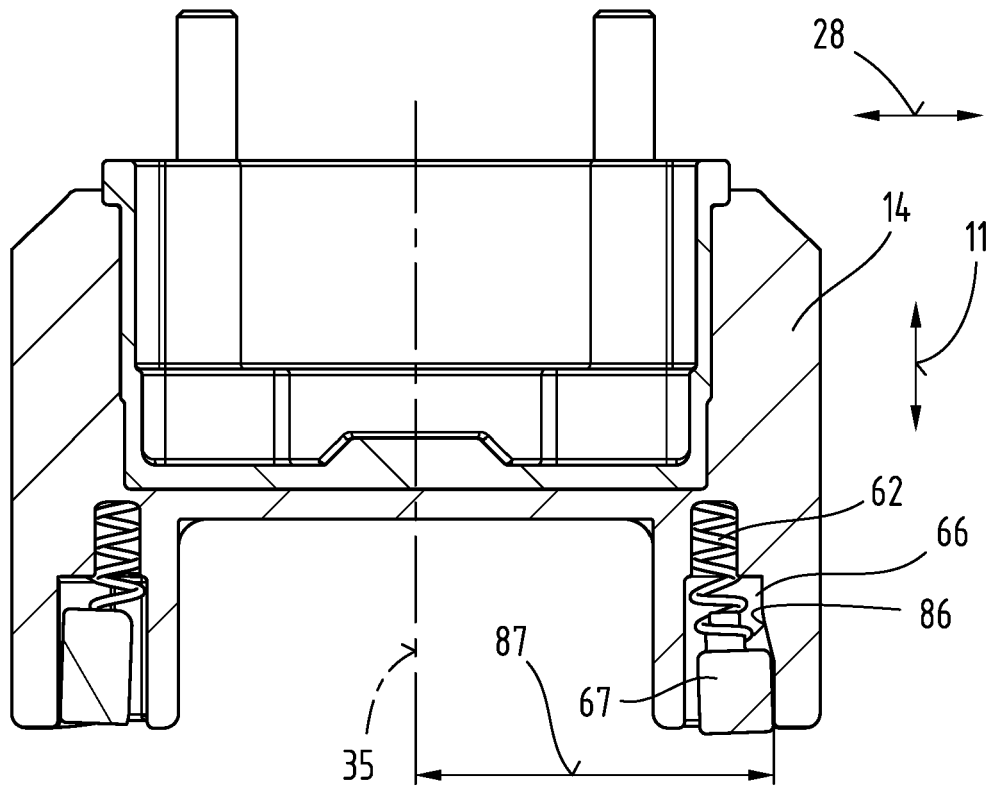
**Fig. 3**

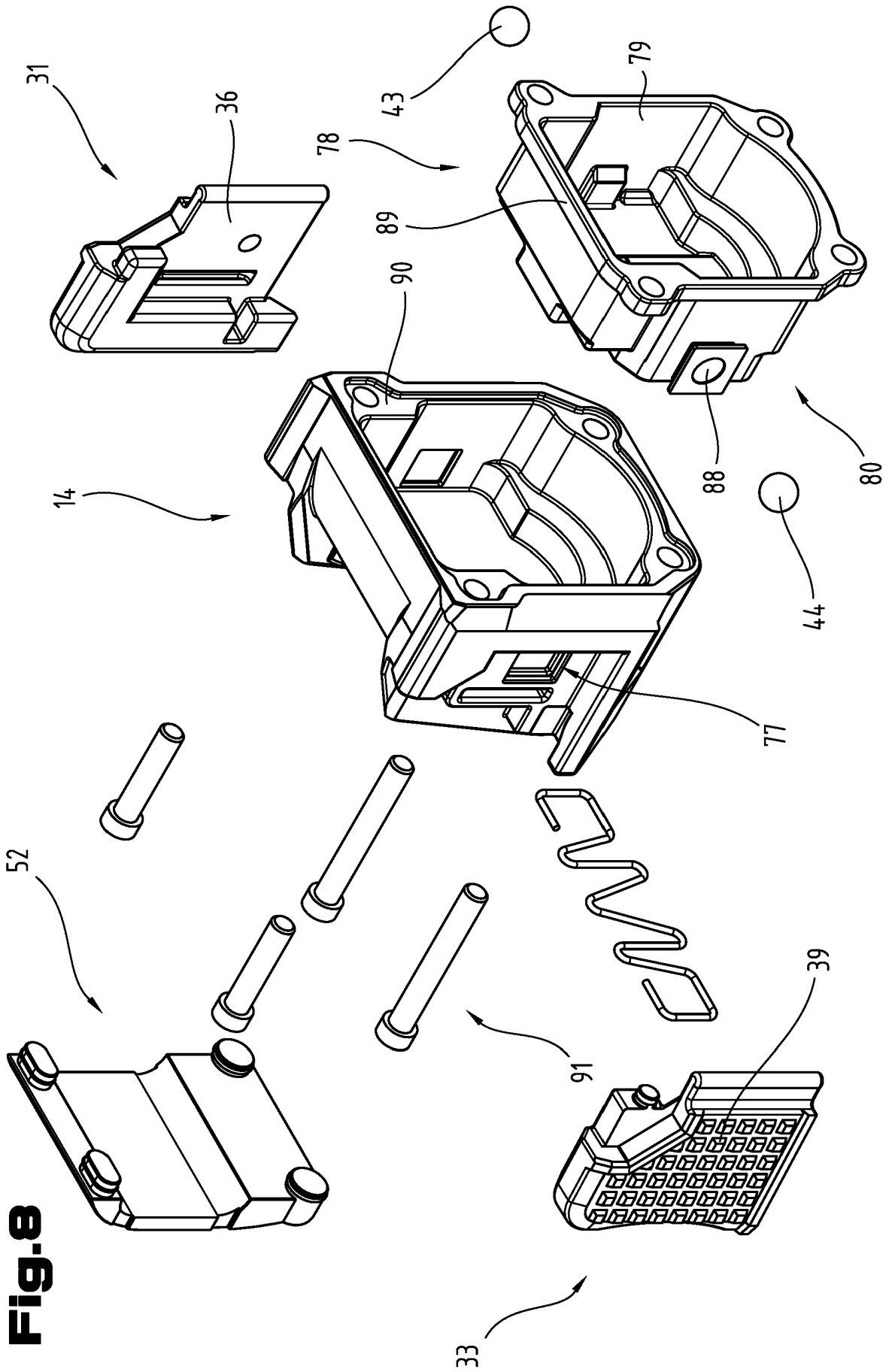


**Fig.6**



**Fig.7**





**Fig. 8**

**REFERENCES CITED IN THE DESCRIPTION**

*This list of references cited by the applicant is for the reader's convenience only. It does not form part of the European patent document. Even though great care has been taken in compiling the references, errors or omissions cannot be excluded and the EPO disclaims all liability in this regard.*

**Patent documents cited in the description**

- US 11105586 B2 [0005] [0006]
- US 2022042675 A1 [0007]
- US 2021025568 A1 [0008]
- EP 3892954 A1 [0042]