

(No Model.)

B. F. MOONEY.  
CLAPBOARD HOLDER.

No. 445,681.

Patented Feb. 3, 1891.

Fig. 1.

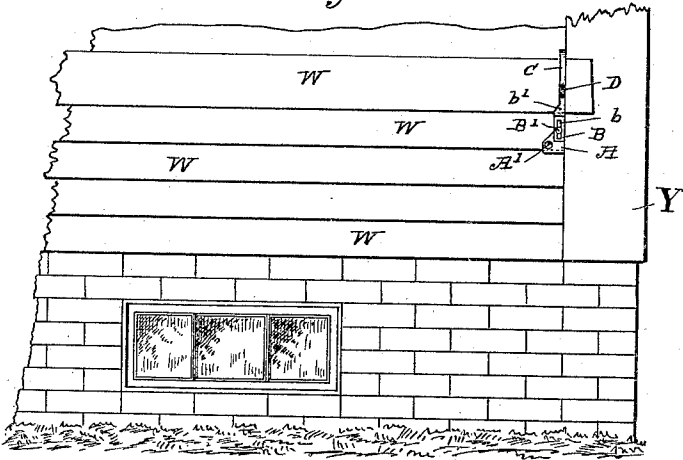

Fig. 5

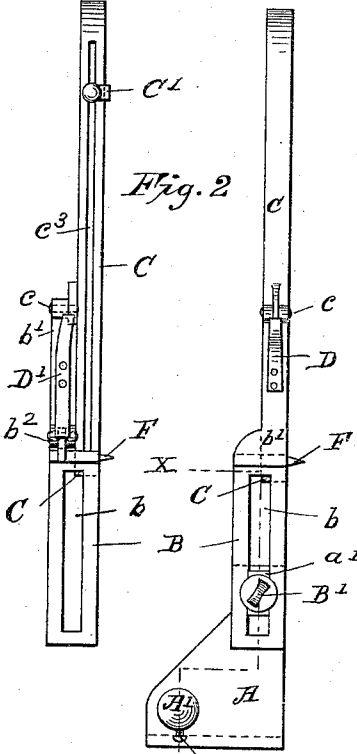

Fig. 2

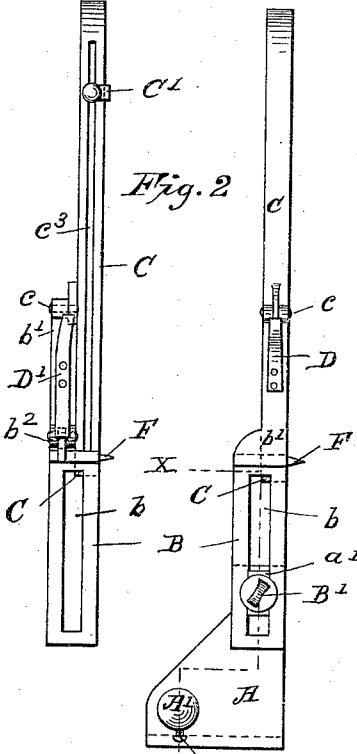

Fig. 3

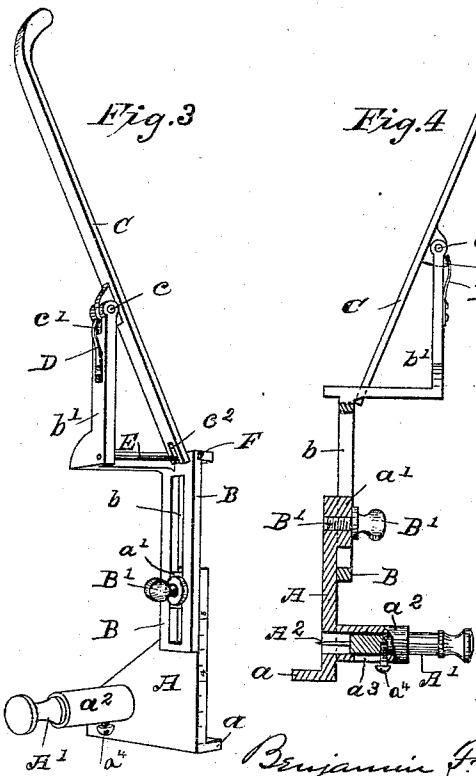

Fig. 4

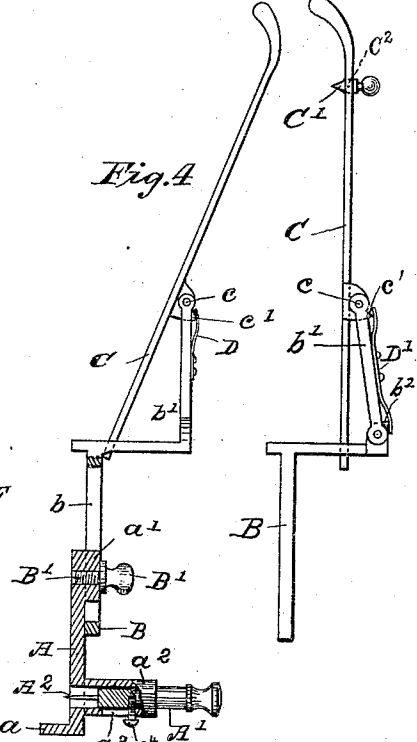
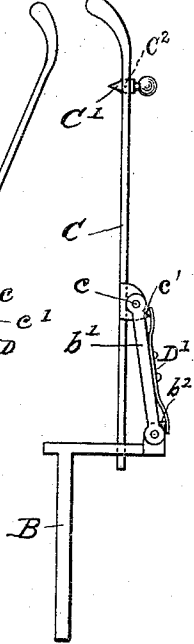

Fig. 6



Witnesses  
F. A. Merrin  
H. M. Danforth,

Inventor  
Benjamin F. Mooney  
By his Attorney J. Thurston

# UNITED STATES PATENT OFFICE.

BENJAMIN F. MOONEY, OF OLEAN, NEW YORK.

## CLAPBOARD-HOLDER.

SPECIFICATION forming part of Letters Patent No. 445,681, dated February 3, 1891.

Application filed April 2, 1890. Serial No. 346,313. (No model.)

*To all whom it may concern:*

Be it known that I, BENJAMIN F. MOONEY, a citizen of the United States, residing at Olean, in the county of Cattaraugus and State of New York, have invented certain new and useful Improvements in Clapboard-Holders, of which the following is a specification.

The object of this invention is to provide a device capable of supporting a clapboard in proper position relative to the others ready to be marked for cutting off, and also while being nailed in place.

This invention is a modification of that shown and described in United States Patent No. 421,746, granted to me on February 18, 1890, and will be fully set forth in the following specification and claims and clearly illustrated in the accompanying drawings, forming a part thereof, of which—

Figure 1 represents a broken elevation of one corner of a clapboarded building with one of my improved adjustable brackets in position supporting one end of a clapboard ready to be marked for sawing off. Fig. 2 is an enlarged front elevation of the device. Fig. 3 is an enlarged perspective view of same. Fig. 4 is an enlarged sectional elevation, Figs. 5 and 6 being, respectively, a front and edge view of a modification of a portion of the gage and working arm.

Similar letters refer to like parts.

The gage is formed in two parts A B, the former having a flange *a* on its lower edge for bearing against the under edge of a clapboard W, and on its front side near the top is formed a rectangular tongue *a'*, which enters a slot *b*, formed in the part B, and by aid of a thumb-screw B', threaded to the block or tongue *a'* and having a flange large enough to bear upon the part B on each side of the slot *b*, the two parts A B may be adjusted as desired and secured firmly together. The part A is also provided with a cylindrical projection *a*<sup>2</sup>, perforated lengthwise, and to this is fitted a stud A', carrying in its end adjacent to a clapboard the awl A<sup>2</sup>. After the gage shall have been placed in position this stud may be struck with a hammer, and thus drive the awl into the clapboard, making a "starter" for a nail. The projection *a*<sup>2</sup> may be slotted, as at *a*<sup>3</sup>, (seen in Fig. 4.) by means of which slot a screw *a*<sup>4</sup> may be threaded to

the stud, and thus limit the stroke of the same and prevent its accidental displacement.

To the right-angled projection *b'* of the part B is pivoted at *c* an arm or rocker C, the normal position of which when the gage is not in use is as illustrated in Figs. 3 and 4, and is so maintained by the action of a suitable spring D, attached to the arm or projection *b'*, bearing upon the projection *c'* of the rocker C. The lower end of the latter is slotted at *c*<sup>2</sup> to receive the rod E, extending from one to the other of the parallel portions of the part B and its projection *b'*. In this manner the said rocker is maintained at all times in a position parallel with the sides of the gage, so that it may serve the purpose of a carpenter's square for guiding a pencil while marking a board to be sawed off, and at the same time make sure that the sawed end will fit the corner board Y of a building. These tools must be made right and left, so as to be capable of use at either end of a building, and when placing the gage in position it must be tapped gently with a hammer toward the corner board Y, and by this operation the point or brad F is embedded into said corner board, and by aid of the awl A the tool is held with sufficient firmness upon the clapboard last nailed on to support the next board while preparing it for nailing on.

In order to adapt the tool to various thicknesses of boards and to enable the marking-arm C to carry a movable marker, the arm *b'* may be hinged to the part B, and a spring D' attached thereto, one end bearing upon the projection *c'* of the marking-arm C and the other upon a like projection *b*<sup>3</sup>, formed for this purpose upon the right-angled portion of the part B, as shown in Figs. 5 and 6, and by forming a groove or slot *c*<sup>3</sup>, running longitudinally in the arm C, a marker C', having a tongue C<sup>2</sup>, may be fitted therein, as also seen in Figs. 5 and 6, and thus save the time a workman would otherwise occupy in finding a pencil or brad-awl for marking a board.

As an inexpensive manner for securing the marker C' to the rocker-arm C, the tongue C<sup>2</sup> of said marker C' may pass through and project slightly beyond the slot *c*<sup>3</sup> of said rocker-arm C, and said projecting end of the tongue may then be sufficiently spread by a few

blows of a hammer to retain it within the slot.

The operation of this gage is similar to that shown and described in the Patent No. 421,746, above referred to, the principal modifications relating to the rocker or marking arm C and the awl A<sup>2</sup>, the latter in the present case being made a part of the gage and not detachable.

Having described my improvements, what I claim as new is—

1. An adjustable gage for clapboards, comprising the parts A B, a suitable awl attached to the former, a marking-arm or rocker pivotally connected to the latter, having a longitudinal groove or slot, a movable marker C', fitting therein, and a spring for holding said

arm in its normal position, substantially for the purpose set forth.

2. An adjustable gage for clapboards, comprising the parts A B, a suitable awl attached to the former, a marking-arm or rocker pivotally connected at a point between its ends nearest its lower end to the part b' of the latter, and a spring for holding said arm or rocker in its normal position, substantially for the purpose set forth.

In testimony whereof I affix my signature in presence of two witnesses.

BENJAMIN F. MOONEY.

Witnesses:

HORACE A. L. BEARDSLEY,  
WILLIAM V. SMITH.