

July 12, 1938.

E. F. LOWEKE ET AL

2,123,368

IRONING MACHINE

Filed Sept. 22, 1933

7 Sheets-Sheet 1

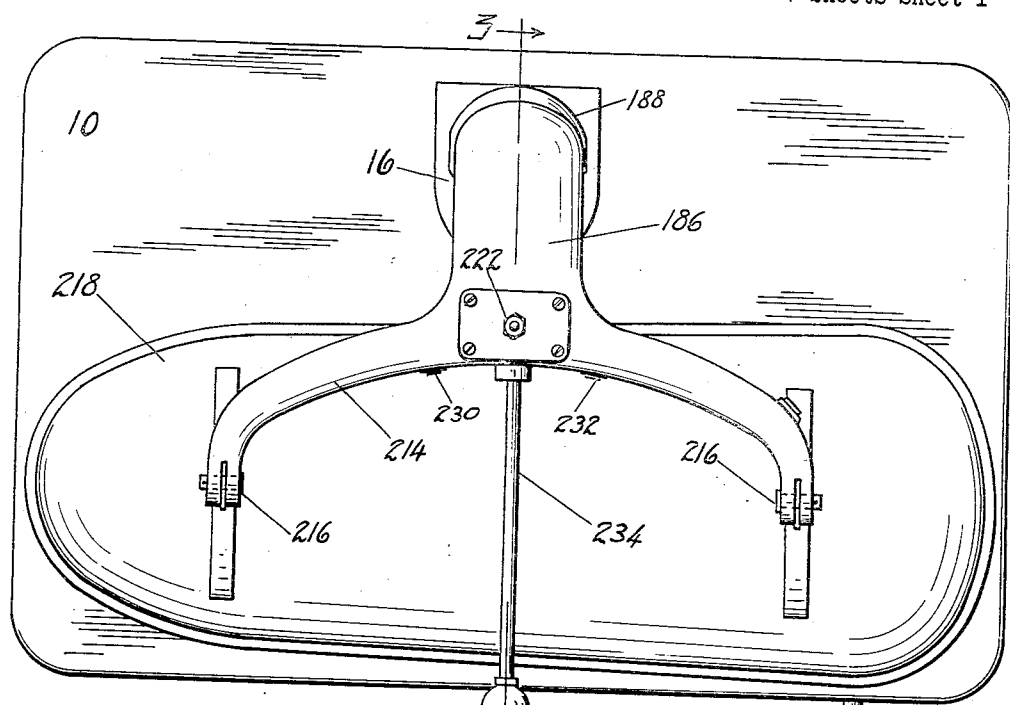

FIG. 1

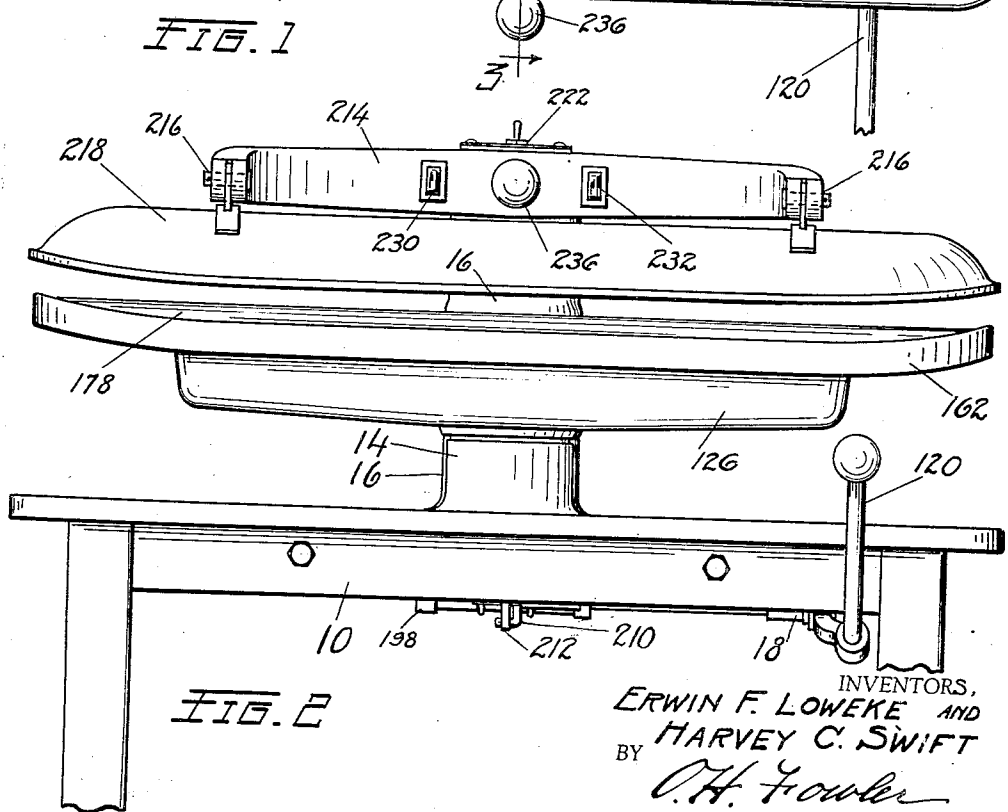

FIG. 2

INVENTORS,
ERWIN F. LOWEKE AND
HARVEY C. SWIFT
BY *O. H. Fowler*
ATTORNEY.

July 12, 1938.

E. F. LOWEKE ET AL
IRONING MACHINE

2,123,368

Filed Sept. 22, 1933

7 Sheets-Sheet 2

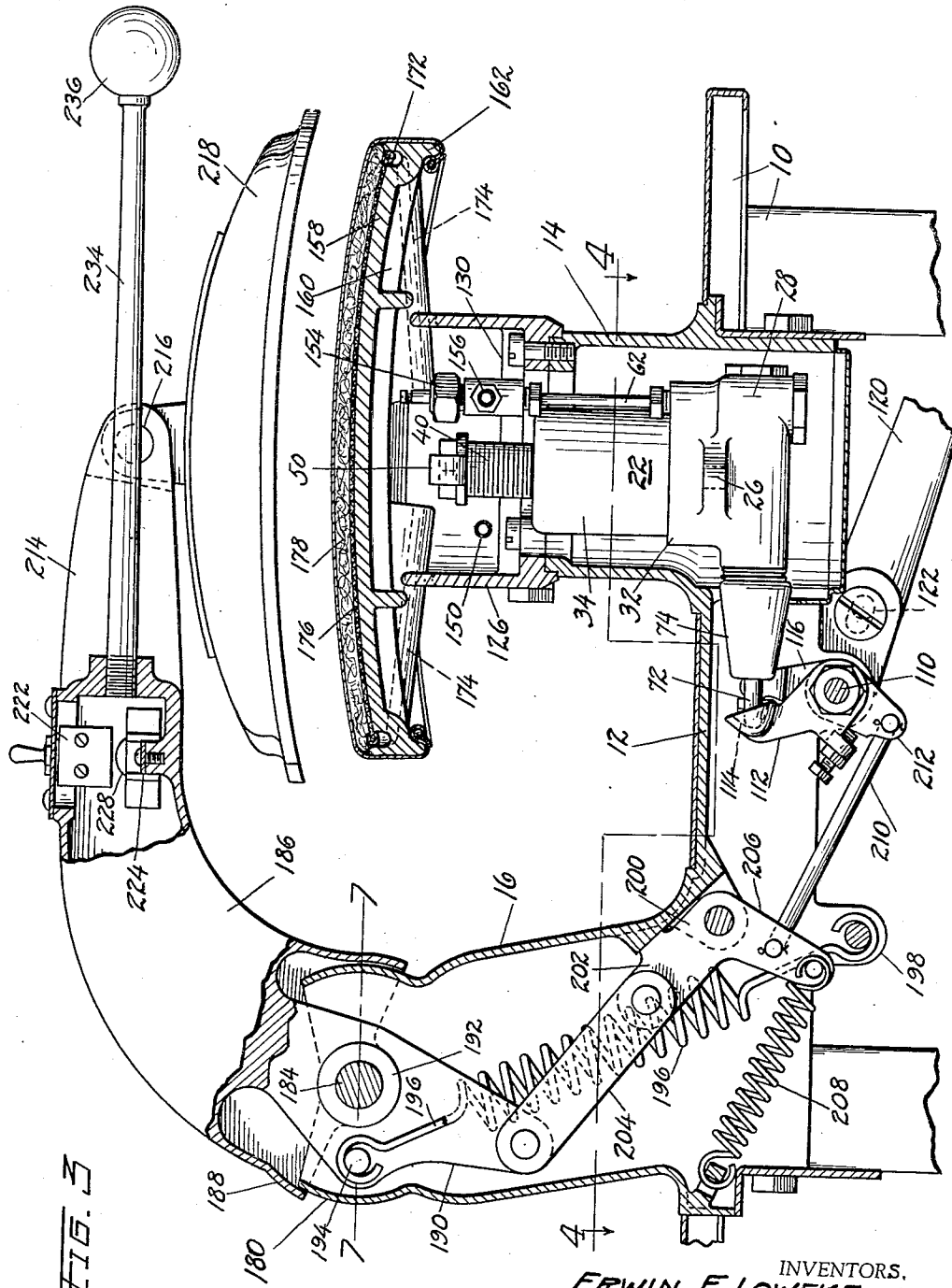

FIG. 3

INVENTORS,
ERWIN F. LOWEKE AND
HARVEY C. SWIFT
BY
O. H. Fowler
ATTORNEY.

July 12, 1938.

E. F. LOWEKE ET AL

2,123,368

IRONING MACHINE

Filed Sept. 22, 1933

7 Sheets-Sheet 3

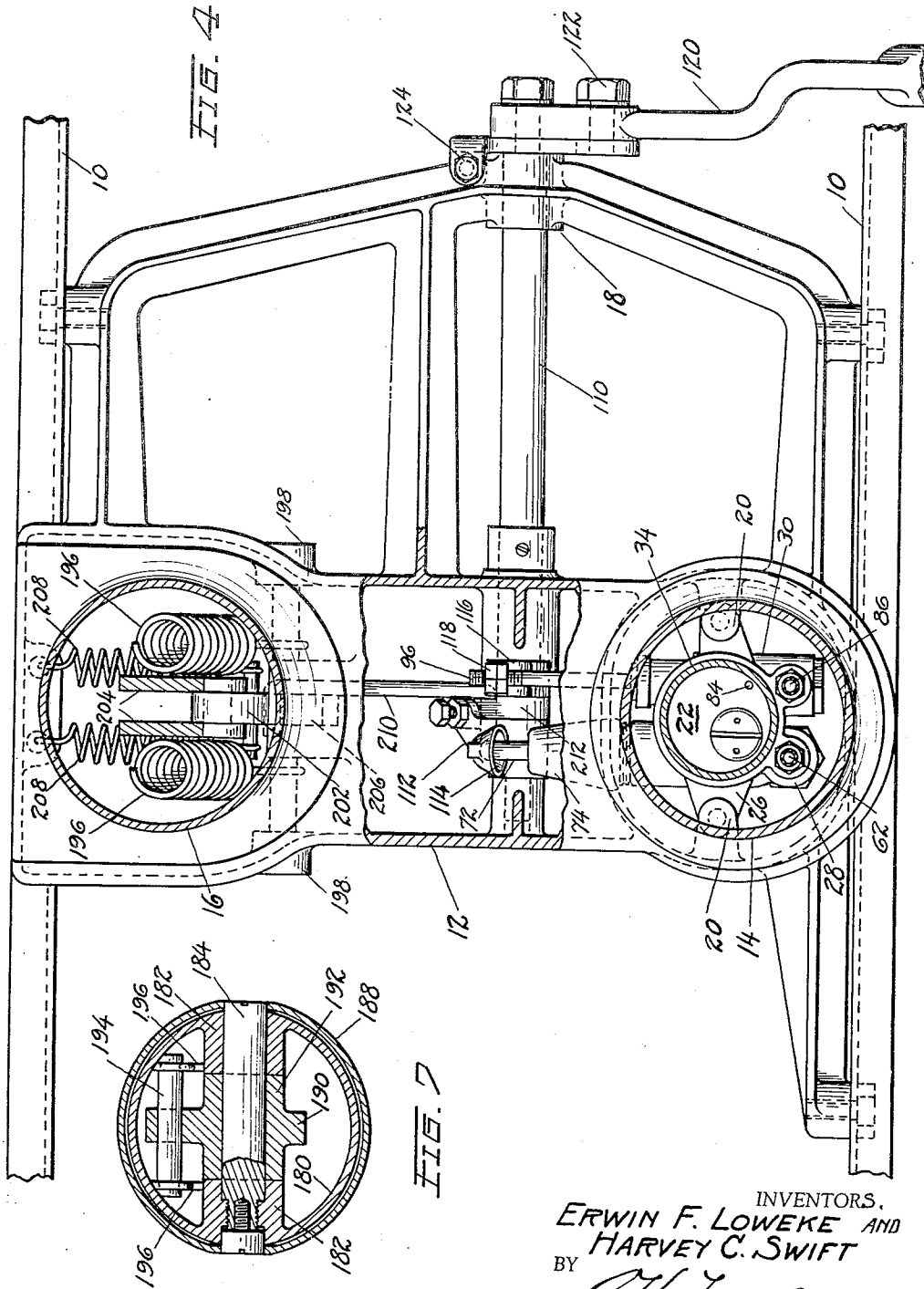

INVENTORS,
 ERWIN F. LOWEKE AND
 HARVEY C. SWIFT
 BY
O. H. Fowler
 ATTORNEY.

July 12, 1938.

E. F. LOWEKE ET AL

2,123,368

IRONING MACHINE

Filed Sept. 22, 1933

7 Sheets-Sheet 4

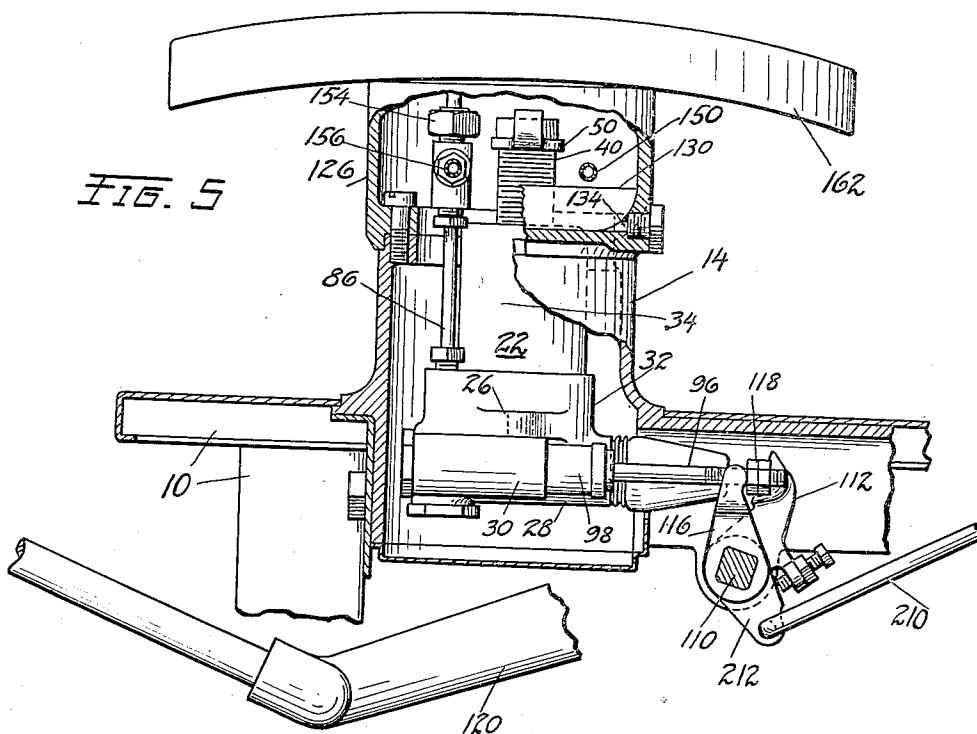

FIG. 5

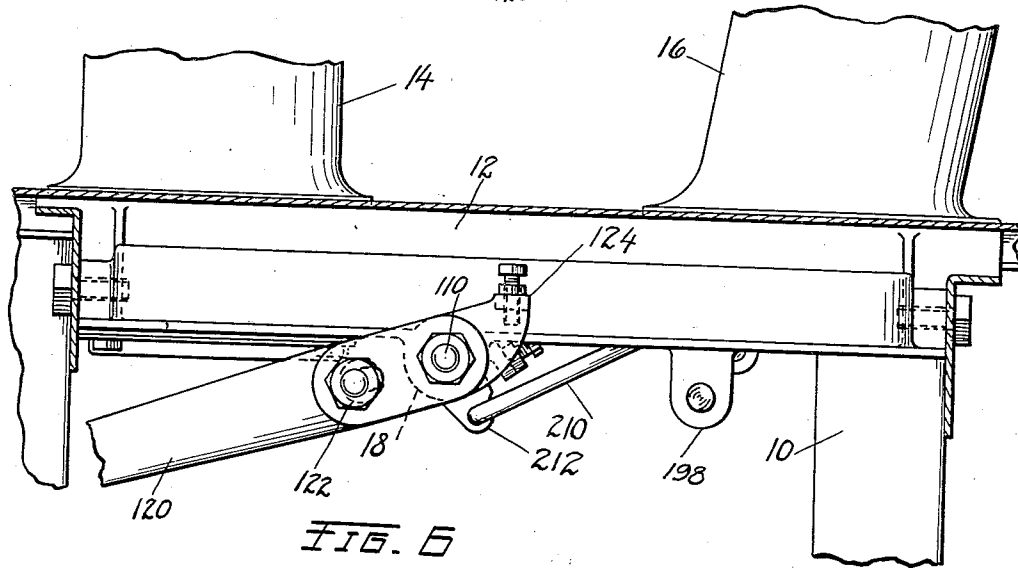

FIG. 6

INVENTORS,
ERWIN F. LOWEKE AND
HARVEY C. SWIFT
BY *O. H. Fowler*
ATTORNEY.

July 12, 1938.

E. F. LOWEKE ET AL
IRONING MACHINE

2,123,368

Filed Sept. 22, 1933

7 Sheets-Sheet 5

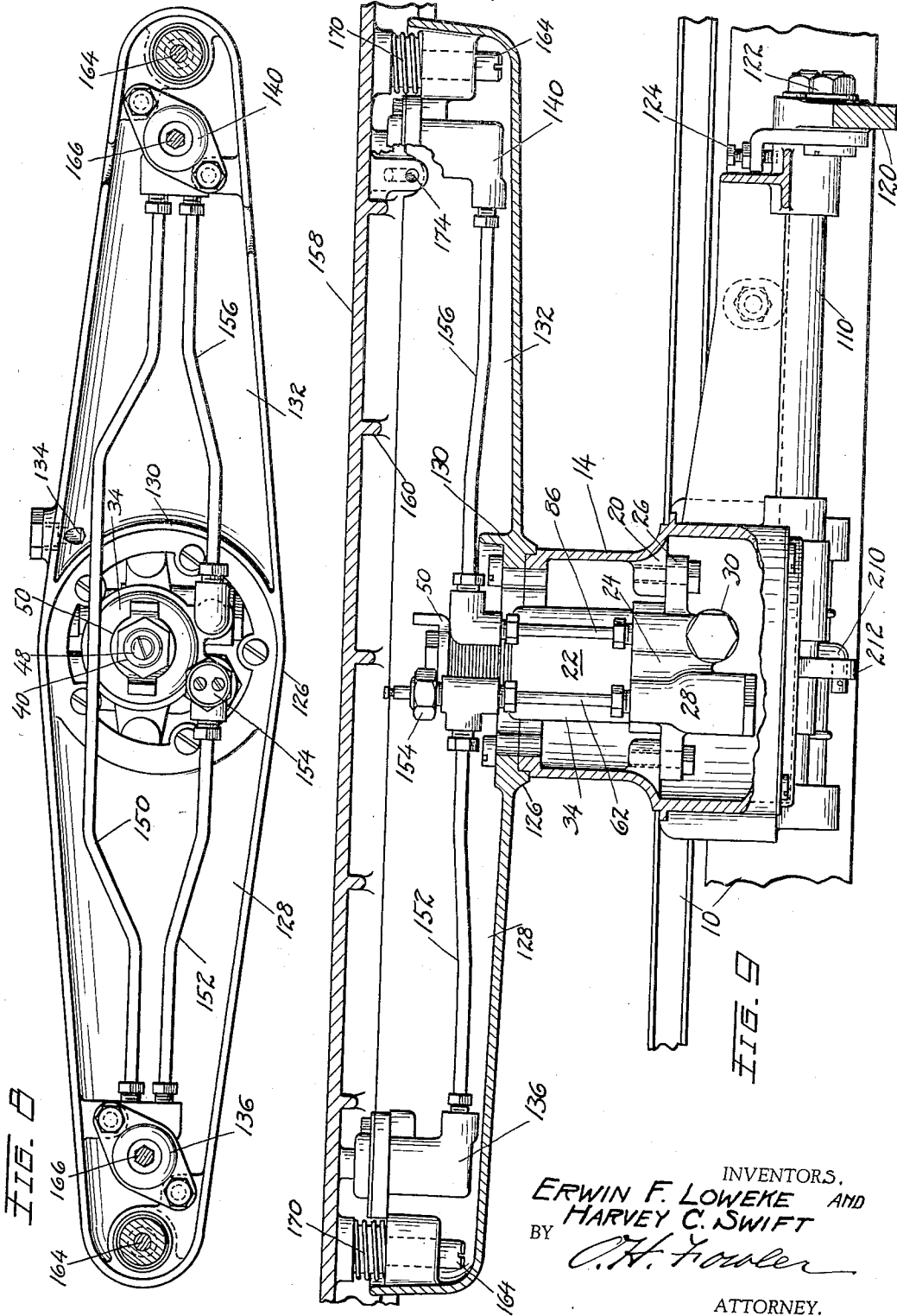

INVENTORS,
ERWIN F. LOWEKE AND
HARVEY C. SWIFT
BY *C. H. Fowler*
ATTORNEY.

July 12, 1938.

E. F. LOWEKE ET AL

2,123,368

IRONING MACHINE

Filed Sept. 22, 1933

7 Sheets-Sheet 6

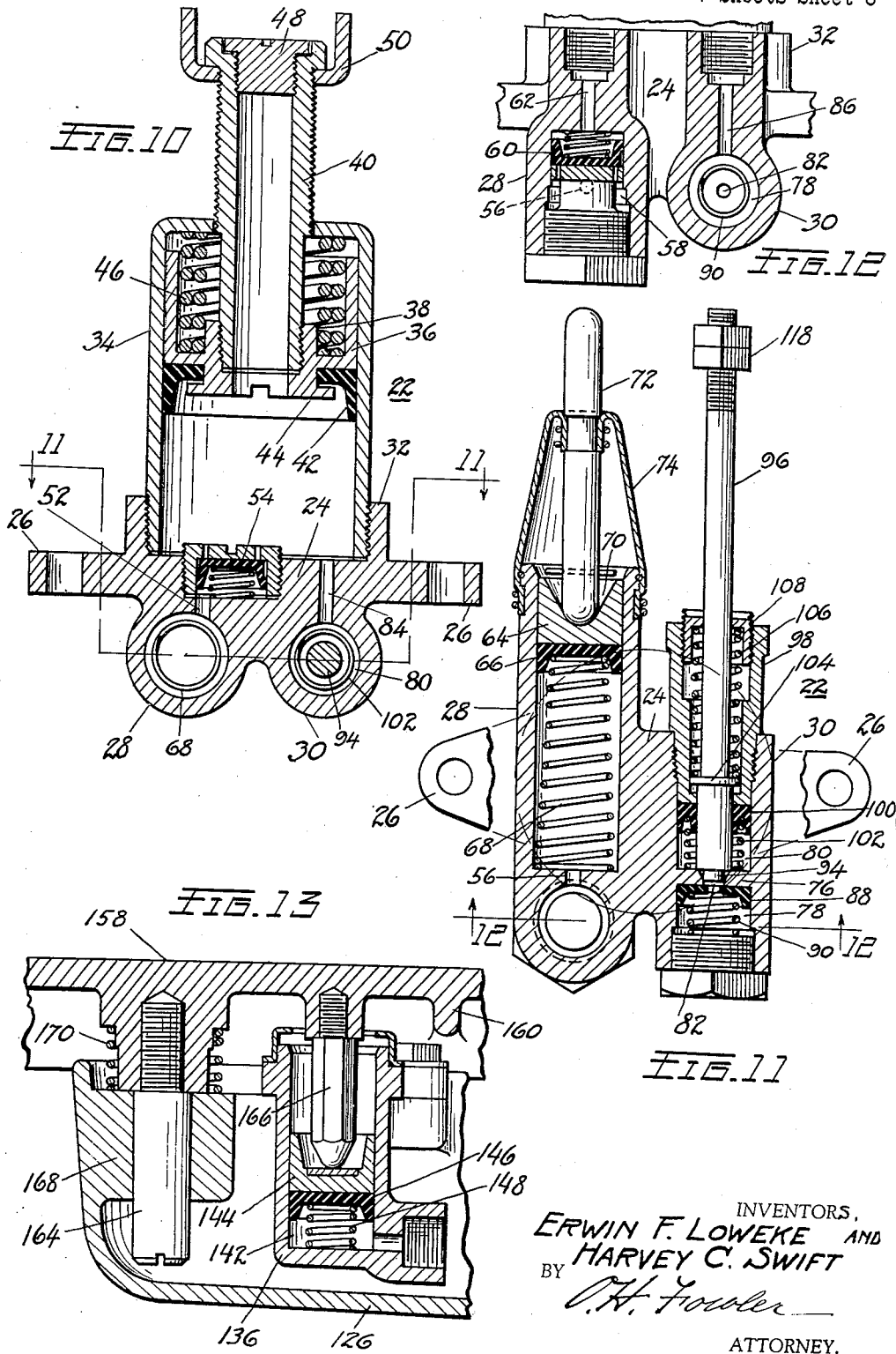

INVENTORS,
ERWIN F. LOWEKE AND
HARVEY C. SWIFT
BY
O. H. Fowler
ATTORNEY.

July 12, 1938.

E. F. LOWEKE ET AL

2,123,368

IRONING MACHINE

Filed Sept. 22, 1933

7 Sheets-Sheet 7

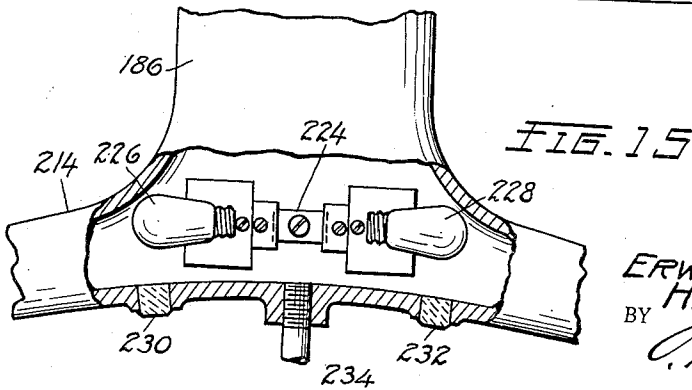
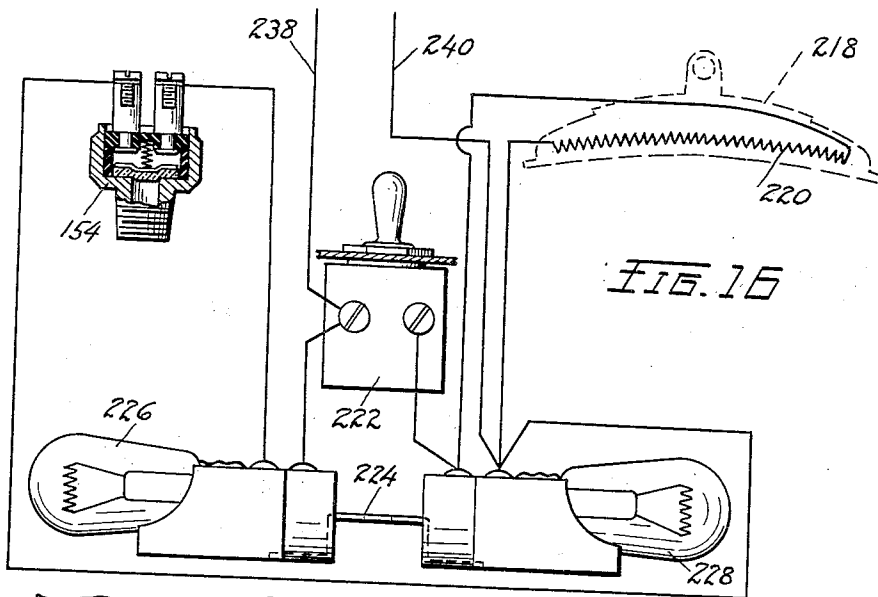
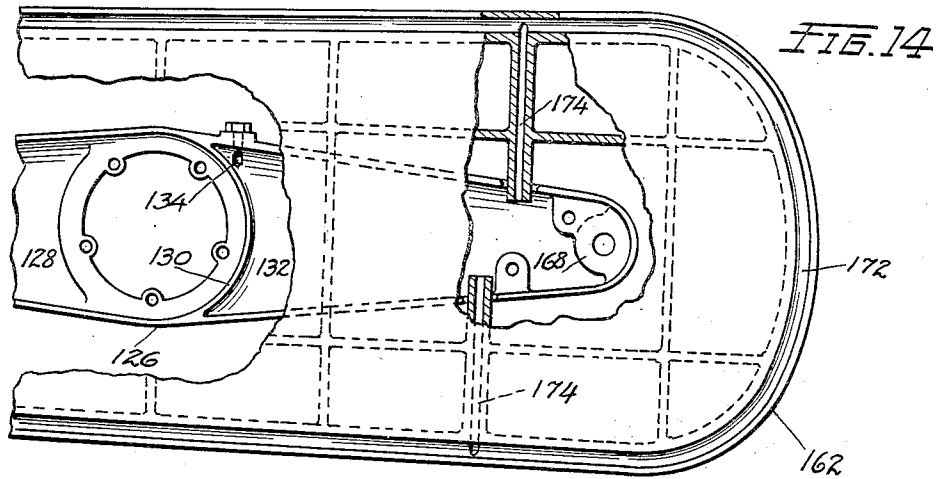

INVENTORS,
ERWIN F. LOWEKE AND
HARVEY C. SWIFT

BY

O. H. Fowler

ATTORNEY.

UNITED STATES PATENT OFFICE

2,123,368

IRONING MACHINE

Erwin F. Loweke and Harvey C. Swift, Detroit,
Mich., assignors to Hydraulic Brake Company,
Detroit, Mich., a corporation of California

Application September 22, 1933, Serial No. 690,620

32 Claims. (Cl. 38—25)

This invention relates to ironing machines, and more particularly to that type known as domestic ironing machines.

An object of the invention is to provide an ironing machine operable by fluid pressure means eliminating undue manual effort on the part of the operator.

Another object of the invention is to provide an ironing machine including relatively movable ironing elements, one being automatically displaceable to compensate for variations in the thickness of the work.

Another object of the invention is to provide an ironing machine including relatively movable ironing elements, one of which is yieldingly supported to compensate for variations in the thickness of work and is operable by a fluid pressure means producing a uniform pressure on the work.

A further object of the invention is to provide an ironing machine including relatively movable ironing elements, and fluid pressure means for actuating one of the elements to produce maximum pressure on the work for the minimum amount of exertion on the part of the operator.

Yet a further object of the invention is to provide an ironing machine including relatively movable ironing elements, and a fluid pressure system for actuating one of the elements including means for supplying fluid under pressure to the system and a pressure producing means for actuating the system.

Other objects and advantages of the invention will more fully appear from the following description taken in connection with the accompanying drawings illustrating a preferred embodiment of the invention, and in which:—

Figure 1 is a top plan view;

Figure 2 is a front elevation;

Figure 3 is a side elevation partly in section;

Figure 4 is a sectional view substantially on line 4—4, Figure 3, parts being broken away;

Figure 5 is a fragmentary view partly in elevation and partly in section illustrating the arrangement of the reservoir and pressure producing means;

Figure 6 is a fragmentary view illustrating the operating lever;

Figure 7 is a sectional view substantially on line 7—7, Figure 3;

Figure 8 is a top plan view of the buck support;

Figure 9 is a longitudinal sectional view with parts broken away;

Figure 10 is a vertical sectional view of the

reservoir and associated pressure producing means;

Figure 11 is a sectional view substantially on line 11—11, Figure 10;

Figure 12 is a sectional view substantially on line 12—12, Figure 11;

Figure 13 is an enlarged detail view of one end of the buck and buck support, including a fluid pressure actuated motor and a guide, parts being broken away;

Figure 14 is a fragmentary view of the buck and buck support;

Figure 15 is a fragmentary view of the horns supporting the head, illustrating the arrangement of the lamps therein, and

Figure 16 is a diagrammatical illustration of the operating circuit.

Referring to the drawings for more specific details of the invention, 10 represents the frame of a table or other suitable support. The frame has bolted or otherwise secured thereto a casting including a housing 12 having at one end thereof a hollow column 14 and at the other end a hollow column 16. The casting also has an outboard bearing 18 preferably connected to the wall of the housing by laterally extended arms.

The column 14 has therein oppositely disposed lugs 20 providing a suitable support for an operating unit indicated generally at 22. This operating unit includes a reservoir, a pressure producing device supplied therefrom, and a relief valve associated with the pressure producing device. As shown, a casting 24 has oppositely disposed lugs 26 by which the casting may be secured to the lugs 20 in the column 14. The casting 24 has formed therein a cylinder 28 and a valve chamber 30 arranged in parallel relation to the cylinder. The casting 24 also has a cylindrical flange 32 to which is suitably secured a reservoir 34 adapted to be filled with suitable fluid. The reservoir has therein a piston 36 having a concentric sleeve 38 into which is threaded a tubular piston rod 40 extending through an opening in the top of the reservoir. A leak-proof cup 42 is fitted on the head of the piston, and held against displacement by a circumferential flange 44 on the sleeve 38; and a coil spring 46 of relatively high tension is interposed between the back of the piston and the top of the reservoir. The free end of the hollow piston rod 40 has threaded therein a plug 48 which may be removed for the purpose of filling the reservoir through the rod 40, and to facilitate this operation a hand nut 50 is threaded on the rod so that

the spring 46 may be compressed during the filling operation.

The cylinder 28 has a port 52 providing a communication between the cylinder and the reservoir 34, and a suitable valve 54 is provided for controlling the port. The cylinder 28 also has a port 56 providing a communication between the cylinder and a chamber 58 having therein a check valve 60 for the control of a discharge passage 62.

A piston 64 reciprocable in the cylinder 28 has on its head a leak-proof cup 66 held against displacement by a return spring 68 for the piston, interposed between the cup and the head of the cylinder; and the back of the piston has a recess 70 for the reception of a rod 72, and the rod is connected to the cylinder by a boot 74 for excluding dust, etc.

The sleeve or valve chamber 30 has a diaphragm 76 which divides the sleeve into two chambers 78 and 80, and a port 82 in the diaphragm provides a communication between the chambers. The chamber 78 is closed as by a plug, and a passage 86 communicating therewith is internally threaded for the attachment of a pipe line or conduit. The chamber 80 has a port 84 providing a communication between the chamber and the reservoir 34. A leak-proof cup 88 is positioned on the diaphragm 76 within the chamber 78 and held against displacement by a spring 90 interposed between the cup and the plug. The cup has an opening registering with the port 82, and the inner perimeter of the cup defining the opening slightly overhangs the perimeter of the diaphragm defining the port, to provide an efficient seal for a valve 94.

The valve 94 has a stem 96 supported for reciprocation in a cage 98 threaded in the open end of the chamber 80, and a leak-proof cup 100 sleeved on the valve stem is seated on the inner end of the cage and held against displacement by a spring 102 interposed between the cup and the diaphragm 76. The valve stem 96 also has thereon a collar 104, and a spring 106 of a predetermined load is interposed between the collar 104 and a ring 108 threaded in the outer end of the cage.

The housing 12 and the off-set bearing 18 support a rockable shaft 110. The shaft has thereon an arm 112, having a recess 114 which receives the piston rod 72. The shaft also carries an arm 116 bifurcated to straddle the valve stem 96 and to engage a nut 118 threaded on the valve stem, so that the valve 94 may be opened manually and also automatically upon a predetermined pressure in the chamber 78. The shaft has suitably secured thereto an operating handle 120 preferably adjustable angularly as by an eccentric 122 and limited in its movement as by a stop 124.

The column 14 has suitably secured thereto a buck support 126 including an elliptical receptacle or bowl 128 having therein a partition or an upwardly extended flange 130 connecting the bottom and side walls of the bowl to provide a compartment 132 having a drain opening 134 adapted to be closed as by a conventional plug.

Suitably supported in the respective ends of the receptacle are expansible elements or fluid pressure actuated motors 136 and 140. Each of these motors includes a cylinder chamber 142 having therein a reciprocable piston 144 having on its head a leak-proof cup 146 held against displacement by a spring 148 interposed between the cup and the head of the cylinder. The motors 136 and 140 are connected as by a pipe line or conduit 150. The motor 136 is connected

by a pipe line or conduit 152 to the discharge passage 62 of the cylinder 28 with a fluid pressure switch 154 interposed; and the motor 140 is connected as by a pipe line or conduit 156 to the return passage 86 controlled by the valve 94.

A buck 158 reinforced by ribs 160 and a marginal flange 162 has dependent pins 164 and 166. The pins 164 are received by apertures in lugs 168 formed in the respective ends of the buck support 126 to provide suitable guides for the buck, and interposed between the buck and the lugs 168 are springs 170 which provide a cushion seat for the buck. The pins 166 extend downwardly into the cylinders of the motors 136 and 140 and engage the piston 144.

As shown, the marginal flange 162 on the buck extends above and below the buck, and a groove 172 in the face of the buck adjacent the flange communicates as by passages 174 with the compartment 132. A suitable screen 176 is fitted on the face of the buck. This screen overhangs the groove 172 and is retained against displacement by the flange 162, and the screen is covered with a suitable fabric 178.

The column 16 has at its upper end a semi-spherical portion 180 in which is formed oppositely disposed bosses 182 bored for the reception of a pin 184. This pin pivotally supports a hollow arm 186 and a semi-spherical portion 188 on the arm telescoping the semi-spherical portion 180 on the column. As shown, the arm 186 has a transverse web having an integral arm 190 projecting downwardly into the column 16. The arm 186 has a bearing 192 receiving the pivot pin 184 and a transverse pin 194 connected by corresponding parallel springs 196 to lugs 198 on the housing 12.

A bell crank lever 200 pivoted on the housing 12 has one of its legs 202 pivoted to one end of links 204, the other ends of which are pivotally connected to the arm 190, and the leg 206 of the bell crank lever 200 is connected by parallel springs 208 to suitable lugs on the housing. The toggle formed by the leg 202 of the bell crank lever 200 and the links 204 is limited in its movement in one direction by a suitable stop on the housing 12. When the toggle engages the stop, the knee of the toggle is slightly past center, and when in this position the toggle serves to lock the arm 186 in a rigid position. The leg 206 of the bell crank lever 200 is connected by a link 210 to an arm or lever 212 mounted loosely on the shaft 110 between the levers 112 and 116 and so engaged by an adjusting screw on the lever 112 that upon movement of the operating lever 112 to relieve the applied force on the pressure producing device, the lever 116 operates to open the valve 94 and the toggle is tripped immediately following the opening of the valve.

The arm 186 has formed integral therewith corresponding oppositely disposed hollow horns 214 having pivoted thereto as at 216 a head 218 adaptable for cooperation with the buck. The head is provided with a conventional heating element 220, and positioned in the arm 186 is a switch 222 for control thereof. The horns have arranged therein a bracket 224 supporting two lamps 226 and 228, the light from which is visible through the colored glass inserts 230 and 232 in the horns. A rod 234 attached centrally between the horns has thereon a handle 236 by which the head may be moved into operative position.

The circuit shown in Figure 16 includes a lead 238 having connected therein the switch 222, 75

lamp 226 and fluid pressure switch 154, also lamp 228. The lamp 226 is effective when the fluid pressure switch 154 is closed at a predetermined pressure, and the light therefrom is visible through the green insert 230. The lead 240 has connected therein switch 222, lamp 228, and heating element 220. The light from the lamp 228 is visible through the red insert 232 which indicates that the heat is on.

In operation, assuming that the electrical circuit of the apparatus or machine is connected to a suitable source of electrical supply, that the system is filled with fluid, that the piston 36 in the reservoir 34 is released to impose an initial pressure on the fluid in the system, and that the head 218 is elevated, under these conditions, upon placing work upon the buck 178 and lowering the head into operative position, the buck, which is yieldingly supported on the springs 170, is depressed correspondingly to the thickness of the work, and also accommodates itself to any variations in the thickness of the work. After the buck is depressed, any excess fluid in the system, including the motors 136 and 140, is returned through the conduits 150 and 156 to the chamber 78 of the relief valve, and from thence through port 82, chamber 80, and port 84 to the reservoir 34. It is to be understood that the initial pressure imposed in the system by the load on the piston in the reservoir is not sufficient to raise the buck but is adequate to retain the pistons of the motors always in engagement with the buck to the end that lost motion is avoided.

Now, upon depressing the lever 120, the shaft 110 is rocked to move the lever 112 through an angle and thereby actuate the piston 64, causing displacement of fluid in the cylinder 28 past valve 60, through port 62, conduit 152, into motor 136, through this motor and conduit 150 into motor 140, through motor 140, conduit 156 and passage 86, to relief valve 94 loaded to crack at a predetermined pressure somewhat in excess of the pressure necessary to effectively iron the work.

Upon delivery of fluid from the cylinder 28 of the fluid pressure producing device to the motors 136 and 140, the motors are actuated to move the buck against the head to create sufficient pressure between them to effectively iron the work. Because of the particular arrangement of the pressure producing device, the motors, and their connections, the buck is floated on a column of fluid which provides perfect equalization and hence uniform distribution of pressure.

When pressure is built up to a sufficient intensity to effectively iron the work, the pressure switch 154 is actuated to close the circuit 238 and thereby light the lamp 226, the light from which is visible to the operator through the green insert 230 in the horn 214. Should the operator apply excessive force to the operating handle 120 causing undue movement of the piston 64 in the cylinder 28 resulting in excessive pressure in the system including the motors 136 and 140, the safety valve 94 cracks and returns the fluid through valve chamber 78, port 82, valve chamber 80, and port 84 to the reservoir.

Upon completing the ironing operation, the operator raises the handle 120, resulting in movement of the lever 112 through an angle to relieve the applied force on the piston 64. With the applied force removed, the piston is returned to its retracted position by the return spring 68.

As the piston 64 returns to its retracted position, the valve 60 closes to prevent retrograde movement of the fluid in the system.

Simultaneously with the movement of the lever 112 to relieve the applied force on the piston of the pressure producing device, the lever 116 is actuated to open the relief valve and return excess fluid in the system to the reservoir. Concomitantly with this operation the lever 212 is actuated through its adjustable connection with the lever 112 to exert a pull on the link 210 and thereby trip the toggle 200, whereupon the springs 195 automatically swing the arm 186 on its pivot 184, resulting in elevating the head 218 to inoperative position.

Although this invention has been described in connection with certain specific embodiments, the principles involved are susceptible of numerous other applications that will readily occur to persons skilled in the art. The invention is, therefore, to be limited only as indicated by the scope of the appended claims.

We claim:—

1. An ironing machine comprising a head movable manually into operative position, means for locking the head in operative position, a reciprocatory buck cooperating with the head, fluid pressure means for actuating the buck, means operated manually for actuating the fluid pressure means including means for unlocking the locking means, and means effective upon unlocking the locking means to move the head to inoperative position.

2. An ironing machine comprising a head movable manually into operative position, means for locking the head in operative position, a reciprocatory buck cooperating with the head, fluid pressure means for actuating the buck, means for relieving pressure in the fluid pressure means, means operated manually for actuating the fluid pressure means including means for actuating the relief means and unlocking the locking means, and means effective upon unlocking the locking means to move the head to inoperative position.

3. An ironing machine comprising a head movable manually into operative position, means for locking the head in operative position, a reciprocatory buck cooperating with the head, hydraulic means for actuating the buck, means for supplying fluid under an initial pressure to the hydraulic means, relief means for the hydraulic means, pressure producing means for the hydraulic means, means for actuating the pressure producing means including means for actuating the relief means and the locking means, and means effective upon unlocking the locking means to move the head to inoperative position.

4. An ironing machine comprising a head movable manually into operative position, means for locking the head in operative position, a reciprocatory buck cooperating with the head, means yieldingly supporting the buck, fluid pressure means for actuating the buck, means for supplying fluid under pressure to the fluid pressure means, a relief means for the fluid pressure means, a pressure producing means for the fluid pressure means, means for actuating the pressure producing means including means for actuating the relief means and the locking means, and means effective upon unlocking the locking means to move the head to inoperative position.

5. An ironing machine comprising a head movable into and from operative position, linkage including a toggle movable past dead center for locking the head in operative position, tension

members for retaining the toggle past dead center, and means for tripping the toggle including an operating shaft, a lever arm on the shaft, a link connecting the lever arm to the toggle, and tension members effective upon tripping the toggle to move the head to inoperative position.

6. An ironing machine comprising a head movable into and from operative position, linkage including a toggle movable past dead center to lock the head in operative position, a reciprocatory buck for cooperation with the head, fluid pressure actuated motors for actuating the buck, a pressure producing device for actuating the motors, an actuator for the device including linkage for tripping the toggle, and tension members effective upon tripping the toggle to move the head to inoperative position.

7. An ironing machine comprising a head movable into and from operative position, linkage including a toggle movable past dead center to lock the head in operative position, a reciprocatory buck cooperating with the head, a fluid pressure system for actuating the buck, a relief valve in the system, an actuator for the system including an arm for actuating the relief valve and an arm for tripping the toggle, and tension members effective upon tripping the toggle to move the head to inoperative position.

8. An ironing machine comprising a head movable into and from operative position, linkage including a toggle movable past dead center to lock the head in operative position, a reciprocatory buck cooperating with the head, a fluid pressure system for actuating the buck, a reservoir for supplying fluid to the system including an element imposing an initial pressure in the system, a relief valve in the system, a pressure producing device for the system, an operative shaft, an operating lever secured thereto, an arm on the shaft arranged to actuate the device when the shaft is rotated in one direction, and a pair of arms on the shaft operative when the shaft is rotated in the other direction to trip the relief valve and the toggle, and tension elements effective upon tripping the toggle to move the head to inoperative position.

9. An ironing machine comprising a head movable manually into operative position, linkage including a toggle for locking the head in operative position, a reciprocatory buck cooperating with the head, yielding supports for the buck to compensate for thickness of work when the head is moved into operative position, a fluid pressure system for actuating the buck, a reservoir for the system including an element imposing an initial pressure in the system, a relief valve in the system, a pressure-producing device in the system, an operating shaft, an operating lever secured thereto, an arm on the shaft arranged to actuate the device when the shaft is rotated in one direction, and a pair of arms on the shaft operative when the shaft is rotated in the other direction to trip the relief valve and the toggle, and tension elements effective upon tripping the toggle to move the head to inoperative position.

10. An ironing machine comprising a head movable manually into operative position, linkage including a toggle for locking the head in operative position, a yieldingly supported reciprocatory buck cooperating with the head, a fluid pressure system for actuating the buck including a pair of fluid pressure actuated motors, a pressure producing device for delivering fluid under pressure to the motors, a relief valve connected in the system, a reservoir for supplying

fluid under pressure to the system, and manually operated means for actuating the device including means for concomitantly actuating the relief valve and breaking the toggle.

11. An ironing machine comprising a housing, cooperative ironing elements supported thereon, a shaft journaled in the housing, an operating lever secured to the shaft, a fluid pressure system including a pressure producing device supported in the housing and fluid pressure actuated motor means connected to the pressure producing device and arranged for actuating one of the elements, an arm on the shaft for actuating the pressure producing device, a relief valve connected in the system, and an arm on the shaft for actuating the relief valve.

12. An ironing machine comprising a housing, cooperative ironing elements supported thereon, a shaft journaled in the housing, an operating lever secured thereto, a fluid pressure system including a pressure producing device supported in the housing, fluid pressure actuated motor means connected to the device and arranged for actuating one of the elements, an arm on the shaft for actuating the device, a relief valve connected in the system, means for operating the relief valve including an arm on the shaft and a lost motion connection between the arm and the relief valve.

13. An ironing machine comprising a housing, cooperative ironing elements supported thereon, a shaft journaled in the housing, an operating lever secured to the shaft, a hollow column communicating with the housing, a fluid pressure system for actuating one of the elements including a pressure producing device supported in the column and fluid actuated motor means connected to the device and arranged to support and actuate one of the elements, a relief valve connected in the system, an arm on the shaft for actuating the device, means for actuating the relief valve including an arm on the shaft and a lost motion connection between the arm and the valve.

14. An ironing machine comprising a support including hollow spaced columns, an arm pivotally supported on one of the columns, an ironing element supported by the arm for movement into and from operative position, means in the column for retaining the arm against movement when the element is in operative position, a support on the other column including an open top receptacle, fluid pressure actuated motor means in the receptacle, an ironing element for cooperation with the first-mentioned ironing element supported and actuated by the motor means, a pressure producing device supported in the last mentioned column and connected to the motor means, and means for operating the pressure producing device and the retaining means.

15. An ironing machine comprising a support including hollow spaced columns, an arm pivotally supported on one of the columns, an ironing element supported by the arm for movement into and from operative position, means in the column for locking the arm against movement when the element is in operative position, a support on the other column including a receptacle communicating with the column, brackets in the receptacle, an ironing element yieldingly supported on the brackets and arranged for cooperation with the first-mentioned ironing element, fluid pressure actuated motor means in the receptacle for actuating the last-mentioned ironing element, a pressure producing device in the last

mentioned column for delivering fluid under pressure to the motor means, and means for actuating the device and unlocking the locking means.

5 16. An ironing machine comprising cooperative ironing elements, a support for one of the elements including an open top receptacle, brackets in the receptacle, means for yieldingly supporting the ironing element on the brackets, fluid pressure actuated motor means in the 10 receptacle for actuating the ironing element, a pressure producing device for delivering fluid under pressure to the motor means, and means for actuating the device.

15 17. An ironing machine comprising cooperating ironing elements, a support for one of the elements including a hollow column, an open top receptacle on the column having an opening in its bottom registering with the column, brackets in the 20 respective ends of the receptacle having openings therein, dependent pins on the back of the ironing element slidable in the openings, springs on the pins between the ironing element and the brackets, fluid pressure actuated motor means in the receptacle for actuating the ironing element, a pressure producing device in the column, fluid 25 pressure delivery pipes housed in the receptacle and the column and connecting the device to the motor means, and means for actuating the device.

30 18. An ironing machine comprising cooperative ironing elements, a support for one of the elements including a hollow column, an elongated open top receptacle on the column having an opening in its bottom registering with the column, a compartment in the receptacle having a drain 35 opening, brackets in the respective ends of the receptacle, and means supporting the ironing element on the brackets above the receptacle, said ironing element having a marginal flange one edge of which extends upwardly, a continuous 40 groove in the upper face of the ironing element adjacent the flange and passages connecting the groove and the compartment.

45 19. An ironing machine comprising an ironing head, a buck adaptable for cooperation therewith, a support for the buck including a receptacle for the reception of condensate produced between the head and the buck, means in the receptacle for yieldingly supporting the buck over the recep- 50 tacle, expansible elements in the receptacle for actuating the buck, a fluid pressure producing device connected to the expansible elements, and means for operating the device.

55 20. An ironing machine comprising a pair of cooperative ironing elements, a support for one of the ironing elements including an open top receptacle, supports in the respective ends thereof, an ironing element yieldingly supported on the supports, expansible elements on the supports for 60 actuating the ironing element, the ironing element having a marginal flange extending above the upper face of the element and below its edge, a continuous groove in the upper face of the element adjacent the flange, and ribs on the back of 65 the element certain of which have passages providing communications between the groove and the receptacle.

70 21. In an ironing machine, an ironing element including a convex plate having a peripheral flange one edge of which extends above the plate and a groove in the face of the plate adjacent the flange, and ribs on the back of the plate certain of which have drain passages communi- 75 cating with the groove.

75 22. In an ironing machine, an ironing element

including a convex plate having a peripheral flange extending above and below the plate and a continuous groove in the upper face of the plate adjacent to the flange, ribs on the back of the plate certain of which have drain passages communicating with the groove, and a screen on the plate retained in position by the flange.

23. In an ironing machine, an ironing element including a convex plate having a perimetral flange extending above and below the plate and 10 a continuous groove in the face of the plate adjacent the flange, ribs on the back of the plate certain of which have drain passages communicating with the groove, and a screen on the plate having its perimeter overhanging the groove and 15 engaging the flange.

24. An ironing machine comprising a base, a hollow support thereon, an arm pivoted on the support, an ironing element suspended from the arm, a toggle in the hollow support for actu- 20 ating the arm, means for actuating the toggle, and a tension element connected between the toggle and the base tending to break the toggle.

25 25. An ironing machine comprising a base, a hollow support thereon, an arm pivoted to the support, an ironing element suspended from the arm, a toggle in the support connecting the arm to the base, means for actuating the toggle to lock the head against movement when in operative position, means for tripping the toggle, and means 30 effective upon tripping the toggle for actuating the toggle to raise the arm.

26. An ironing machine comprising cooperative ironing elements, a base, a hollow support there- 35 on, an arm supporting one of the ironing elements, said arm being pivoted on the support and having a part extending into the support, a toggle including a bell crank lever having its knee pivoted on the base and a link connecting one leg of the lever to the part, means connected to the other 40 leg of the lever for actuation thereof, a fluid pressure system for actuating the other ironing element, and means for operating the fluid pressure system including means for breaking the toggle.

45 27. An ironing machine comprising cooperative ironing elements, a base, a hollow support thereon, an arm supporting one of the ironing elements, said arm being pivoted to the support and having a part extending into the support, 50 a toggle including a bell crank lever having its knee pivoted on the base and a link connecting one leg of the lever to the part, a spring connecting the other leg of the lever to the base, springs connecting the part to the base, a fluid 55 pressure system for actuating the other ironing element, and means for actuating the fluid pressure system including means for breaking the toggle.

60 28. An ironing machine comprising cooperative ironing elements, a base, a hollow support thereon, an arm pivoted thereto, supporting one of the ironing elements, a toggle including a bell crank lever partly in the support, the knee of the lever being pivoted on the base, a link in the support 65 connecting one leg of the lever to the arm, a spring connecting the other leg of the lever to the base for urging the toggle past dead center to retain the arm against movement, springs in the support connecting the arm to the base tend- 70 ing to raise the arm, means for tripping the toggle, a fluid pressure system for actuating the other ironing element, and means for operating the fluid pressure system including means for actu- 75 ating the tripping means.

29. An ironing machine comprising cooperative ironing elements, one movable manually into operative position, means for moving this element to inoperative position, a fluid pressure system for actuating the other ironing element including a cylinder, a piston movable therein, a reservoir communicating with the cylinder, a check valve controlling the communication, a relief valve connected in the system, a spring-loaded piston in the reservoir imposing an initial pressure in the system, and means for actuating the piston including means for tripping the relief valve.

30. An ironing machine comprising cooperative ironing elements, one movable manually into operative position, means for locking this element in operative position, a fluid pressure system for actuating the other ironing element including a cylinder, a piston movable therein, a reservoir for supplying fluid to the cylinder, a check valve for controlling the passage between the cylinder and the reservoir, a relief valve connected in the system, a spring-loaded piston in the reservoir imposing an initial pressure in the system, means for filling the reservoir through the piston, and means for actuating the piston in the cylinder including means for tripping the relief valve.

31. An ironing machine comprising cooperative ironing elements, a support for one of the ironing elements, an electrical circuit, a heating element for the ironing element connected in the circuit, a switch for control of the circuit, means connected in the circuit giving a visual indica-

tion when the circuit is closed, a fluid pressure system for actuating the other ironing element to create an ironing pressure between the ironing elements, a second circuit tapped off of the first circuit, a fluid pressure switch connected in the system and in the second circuit operative to close the second circuit when the ironing pressure is created, means connected in the second circuit for giving a visual indication when the second circuit is closed, and means for operating the fluid pressure system.

32. An ironing machine comprising cooperative ironing elements, a support for one of the ironing elements, an electrical circuit housed in the support, a heating element arranged in the support element and connected in the circuit, a switch in the support for control of the circuit, a signal device in the support indicating when the circuit is closed, a fluid pressure system for actuating the other ironing element to create an ironing pressure between the ironing elements, a second circuit in the support tapped off of the first circuit, a fluid pressure switch connected in the system and the second circuit operative to close the second circuit when the ironing pressure is attained, a signal device connected in the second circuit for giving an indication when the second circuit is closed, and means for operating the fluid pressure system.

ERWIN F. LOWEKE. 30
HARVEY C. SWIFT.