

June 13, 1961

W. E. PERKINS

2,987,794

TROWEL FOR PIPE LINING MATERIAL

Filed May 27, 1960

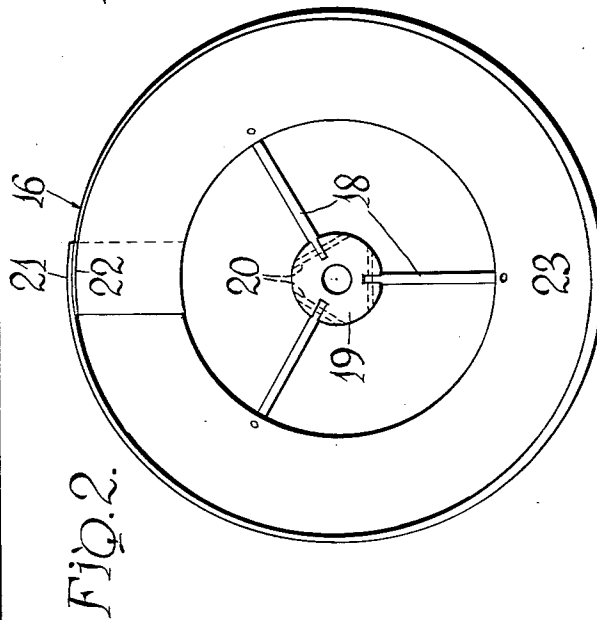
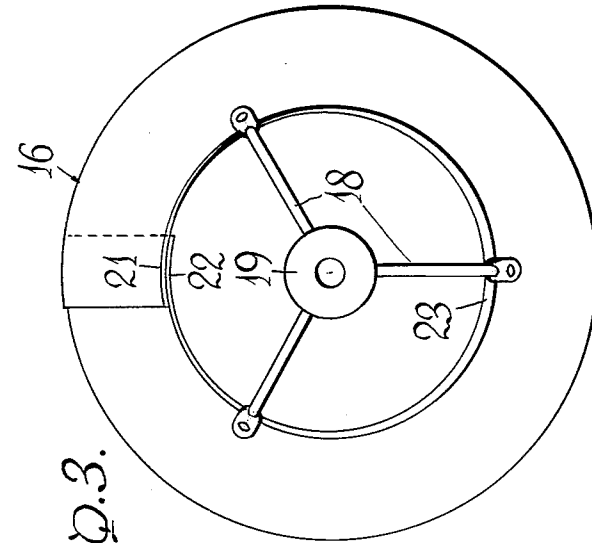
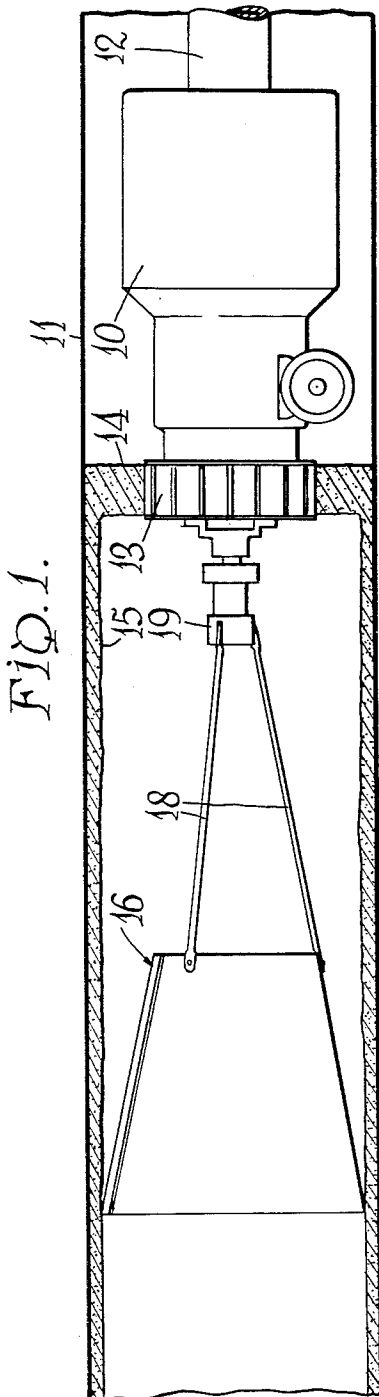

INVENTOR
Warren E. Perkins,

BY *Bean, Brooks, Buckley & Bean*
ATTORNEYS

1

2,987,794

TROWEL FOR PIPE LINING MATERIAL

Warren E. Perkins, Grand Island, N.Y., assignor to Perkins Pipe Linings, Inc., Grand Island, N.Y.

Filed May 27, 1960, Ser. No. 32,287

10 Claims. (Cl. 25—38)

This invention relates to apparatus for lining the interior of pipe with a protective coating of mortar or the like and particularly to a troweling means for smoothing the surface of an interior coating or lining of mortar after the same has been deposited against the interior wall of the pipe.

My prior Letters Patent No. 2,924,867 granted February 16, 1960 shows apparatus adapted to be drawn through underground pipe for depositing a continuous layer of mortar against the interior of the pipe and for smoothing the same by means of a troweling device which follows the depositing apparatus. My present trowel invention provides means which eliminates certain extraneous tensioning or spring biasing devices and certain diameter-limiting or diameter-controlling devices and thus produces a simpler trowel structure wherein all of the biasing and shape-limiting forces are inherent in the trowel element itself.

Speaking generally, the trowel element of the present invention comprises a sheet of metal or analogous self-sustaining but resilient material bent to form a conical frustum. In use this conical frustum is drawn through the pipe with its small end first so that the flaring peripheral wall of the frustum adjacent to the large trailing end applies radially outward troweling pressure against the plastic mortar which has been applied to the interior wall of the pipe.

In a preferred form the opposite side edges of the metal sheet overlap slightly along a line extending from the small diameter end to the large diameter end of the frustum and these overlapped portions are unconnected so that the frustum may contract yieldingly under external, generally radial forces which result from the trowel being drawn through a pipe which has been interiorly coated with mortar. Viewed conversely, the trowel will tend to expand resiliently outwardly against such coating to smooth the same as the trowel passes along.

While the trowel element may be to some extent subject to temporary local deformation, as when an obstruction is encountered such as a projection from the interior wall of the pipe, it is desired that the trowel tend to maintain its circular shape even though the diameter of its large end may be caused to vary somewhat due to variations in pipe diameter or, more usually, variations in the thickness of the mortar which has been applied.

In a preferred form this tendency to maintain circularity is materially enhanced and promoted by employing a sheet which is materially thicker along a medial line or zone lying diametrically opposite to the lapped edges of the sheet and extending generally from the large diameter end to the small diameter end of the frustum. This thickness of the sheet, in this form of the invention, tapers gradually to the lapped edges, where the sheet is of at least thickness. This general effect may be attained in a sheet of uniform thickness by providing integral reinforcement along the aforesaid medial portions of the sheet.

The general effect of the tapering sheet or the medially reinforced sheet is similar to that of a simple beam of uniform strength which is deeper at the center than at its ends. As viewed along the axis, the trowel may be said to comprise a beam of uniform strength bent into circular form with its ends overlapping. The use of the term "uniform strength" is only an approximation and refers to the fact that medial portions are somewhat stiffer and less flexible than the overlapping edge portions of the sheet.

2

The effect of employing this general principle of construction of the trowel body is that radially inward forces against the same at various points about the periphery of the large end produce approximately equal or uniformly proportionate inward deflections of the trowel body.

A single specific embodiment of the principles of the present invention is illustrated in the accompanying drawing and described in detail in the following specification. However, it is to be understood that such embodiment is by way of example only and that various mechanical modifications may be introduced without departing from the spirit of the invention, the scope of which is limited only as defined in the appended claims.

In the drawing:

FIG. 1 is a longitudinal cross-sectional view through a pipe being lined by a pipe lining apparatus having in combination therewith a trowel element or component constructed in accordance with one form of the present invention;

FIG. 2 is an end elevational view of the troweling element of FIG. 1 viewed from the left-hand side of FIG. 1, that is, from the trailing end of the troweling element;

FIG. 3 is an end elevational view of the troweling element of FIG. 1 viewed from the right-hand end, that is, the leading end of the troweling element.

The details of the apparatus for applying the plastic material to the interior of the pipe are known in the art and shall be referred to only sufficiently to orient the troweling means which forms the particular subject of the present invention.

Referring to FIG. 1, the numeral 10 designates a pipe lining machine which may be of the type illustrated and described in United States Letters Patent No. 2,758,352, the machine 10 being adapted to be drawn through a subterranean pipe 11 by a remote winch and cable means or the like, the movement of the machine 10 being to the right as viewed in FIG. 1 during pipe lining operation thereof.

Mortar is fed to machine 10 through a flexible conduit 12 and merely by way of example is applied to the interior surface of the pipe 11 by a rotary distributor head 13 which discharges the mortar centrifugally as indicated at 14 to apply a more or less rough coating of mortar 15 to the interior of pipe 11. The thickness of the coating is governed by the rate of discharge from distributor head 13 and the rate of movement of the machine through the pipe.

The frusto-conical troweling element itself is designated generally by the numeral 16 and is connected to the pipe lining machine 10 to follow the same through the pipe being lined. To this end a plurality of rods 18 are attached to the leading end of the troweling element 16 as by riveting or the like, and are connected at their opposite ends to a coupling 19 which may be in the form of a hub having free swivel or rotatable connection with the distributor head 13 in order that the troweling element may be drawn through the pipe in a non-rotating condition despite the rotary mortar-distributing motion of the distributor head 13.

The adjacent ends of the rods 18 are pivotally attached to coupling 19 as by pivot pins designated 20 in Fig. 2 so that the troweling element 16 is free to contract and expand diametrically without hindrance from the draft connection provided by the rods 18.

In the present instance the troweling element 16 is formed from a blank sheet of metal of generally quadrilateral form wherein two opposite side edges of the blank are relatively thin as at 21 and 22 as compared with a medial longitudinally extending portion of the blank 23 which is relatively thicker. The thinner edge portions overlap as shown in FIGS. 2 and 3 when the blank is bent to its normal frusto-conical form.

By reason of the tapering thickness of the sheet from which the troweling element is formed the latter will tend to maintain generally true circularity as the same is flexed to different diameters by pressure of mortar bearing generally radially inwardly thereagainst. Nevertheless, the trowel may flex locally when acted upon by local forces such as obstructions projecting radially inwardly from the pipe wall and the troweling element may freely assume a somewhat elliptical form when the pipe through which it is fastened presents such form, which may be particularly when traversing curving portions of the pipe.

As indicated in the preamble hereto, other means of providing the "uniform strength beam" function of the troweling element may be availed of instead of the tapering sheet form illustrated herein by way of example. For instance, additional sheet laminations may be spot welded or otherwise secured to medial portions of the interior surfaces of a base sheet to produce the effect of greater sheet thickness at such medial portions and other medial reinforcing or stiffening means may be integrally incorporated in or applied to the base sheet of which the trowel is fabricated.

Where local extraneous spring devices of one kind or another are attached to the interior of a troweling element of the type here under consideration for applying expanding force thereto the problem of applying such local force in a way to maintain a general circularity of the troweling element is difficult if not insoluble. If the troweling element does not possess the present inherent tendency to maintain circularity throughout its expanse, then if there be an increase in the thickness of the applied coating causing a contracting force upon the trowel, the latter may contract into a somewhat elliptical form which will produce a similarly elliptical interior surface of the applied coating and a consequent variation in the thickness thereof at various points about the wall of the pipe.

It is to be understood that the metal thicknesses illustrated in FIGS. 2 and 3 are exaggerated to some extent for purposes of illustration and that these views are accordingly to some extent merely schematic or diagrammatic to illustrate the tapering nature of the sheet metal for the general reason and purpose discussed earlier herein.

I claim:

1. Trowel means for smoothing a layer of mortar in an interior generally cylindrical surface, said trowel means comprising a sheet of resilient material bent to form a frusto-conical tapering wall with edge portions of the sheet overlapping along a generally axially extending line, said sheet having greater flexural rigidity in a zone extending longitudinally thereof and medially between the aforesaid overlapping edge portions and having progressively less flexural rigidity toward said overlapping edge portions.

2. Trowel means for smoothing a layer of mortar in an interior generally cylindrical surface, said trowel means comprising a sheet of resilient material bent to form a frusto-conical tapering wall with edge portions of the sheet in overlapping otherwise unconnected relationship along a generally axially extending line, said sheet being self-sustaining and having sufficient flexural rigidity in a circumferential direction to resiliently maintain its generally circular form.

3. Trowel means for smoothing a layer of mortar in an interior generally cylindrical surface, said trowel means comprising a sheet of resilient material bent to form a frusto-conical tapering wall with edge portions of the sheet in overlapping otherwise unconnected relationship along a generally axially extending line, said sheet being resiliently self-sustaining throughout but having greater flexural rigidity in a zone extending longitudinally thereof and medially between the aforesaid overlapping edge portions and having progressively less flexural rigidity toward said overlapping edge portions.

4. Trowel means for smoothing a layer of mortar in an interior generally cylindrical surface, said trowel means comprising a sheet of resilient material bent to form a frusto-conical tapering wall with edge portions of the sheet overlapping along a generally axially extending line, said sheet being of greater thickness for greater flexural rigidity in a zone extending longitudinally thereof and medially between the aforesaid overlapping edge portions and having progressively less thickness and less flexural rigidity toward said overlapping edge portions.

5. Trowel means for smoothing a layer of mortar in an interior generally cylindrical surface, said trowel means comprising a sheet of resilient material bent to form a frusto-conical tapering wall with edge portions of the sheet in overlapping otherwise unconnected relationship along a generally axially extending line, said sheet being resiliently self-sustaining throughout but being of greatest thickness in a zone extending longitudinally thereof and medially between the aforesaid overlapping edge portions and having progressively less thickness toward said overlapping edge portions.

6. Trowel means for smoothing a layer of mortar in an interior generally cylindrical surface, said trowel means comprising a sheet of resilient material bent to form a frusto-conical tapering wall with edge portions of the sheet overlapping along a generally axially extending line, said sheet having greater flexural rigidity in a zone extending longitudinally thereof and medially between the aforesaid overlapping edge portions and having progressively less flexural rigidity toward said overlapping edge portions, and means for drawing the trowel member along to trowel said interior surface comprising a plurality of members connecting at spaced points about the periphery of the small end of said trowel means and extending generally axially therefrom to draw the trowel member along without substantially restraining its radial resilience.

7. Trowel means for smoothing a layer of mortar in an interior generally cylindrical surface, said trowel means comprising a sheet of resilient material bent to form a frusto-conical tapering wall with edge portions of the sheet in overlapping otherwise unconnected relationship along a generally axially extending line, said sheet being self-sustaining and having sufficient flexural rigidity in a circumferential direction to resiliently maintain its generally circular form, and means for drawing the trowel member along to trowel said interior surface comprising a plurality of members connecting at spaced points about the periphery of the small end of said trowel means and extending generally axially therefrom to draw the trowel member along without substantially restraining its radial resilience.

8. Trowel means for smoothing a layer of mortar in an interior generally cylindrical surface, said trowel means comprising a sheet of resilient material bent to form a frusto-conical tapering wall with edge portions of the sheet being generally contiguous along a generally axially extending line, said sheet having greater flexural rigidity in a zone extending longitudinally thereof and medially between the aforesaid overlapping edge portions and having progressively less flexural rigidity toward said contiguous edge portions.

9. Trowel means for smoothing a layer of mortar in an interior generally cylindrical surface, said trowel means comprising a sheet of resilient material bent to form a frusto-conical tapering wall with edge portions of the sheet in contiguous unconnected relationship along a generally axially extending line, said sheet being self-sustaining and having sufficient flexural rigidity in a circumferential direction to resiliently maintain its generally circular form.

10. Trowel means for smoothing a layer of mortar in an interior generally cylindrical surface, said trowel means comprising a sheet of resilient material bent to form a frusto-conical tapering wall with edge portions

of the sheet being contiguous along a generally axially extending line, said sheet having greater flexural rigidity in a zone extending longitudinally thereof and medially between the aforesaid contiguous edge portions and having progressively less flexural rigidity toward said overlapping edge portions, and means for drawing the trowel member along to trowel said interior surface comprising a plurality of members connecting at spaced points about the periphery of the small end of said trowel means and extending generally axially therefrom to draw the trowel

5

10

member along without substantially restraining its radial resilience.

References Cited in the file of this patent

UNITED STATES PATENTS

452,938	Gilmore	May 26, 1891
513,176	Davey	Jan. 23, 1894
896,520	Deuchar	Aug. 18, 1908
2,758,352	Perkins	Aug. 14, 1956
2,924,867	Perkins	Feb. 16, 1960