

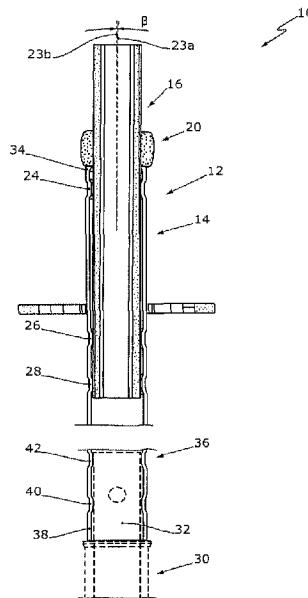

(86) Date de dépôt PCT/PCT Filing Date: 2017/03/01
 (87) Date publication PCT/PCT Publication Date: 2017/09/28
 (45) Date de délivrance/Issue Date: 2024/06/18
 (85) Entrée phase nationale/National Entry: 2018/09/06
 (86) N° demande PCT/PCT Application No.: EP 2017/054773
 (87) N° publication PCT/PCT Publication No.: 2017/162415
 (30) Priorité/Priority: 2016/03/22 (DE10 2016 204 694.2)

(51) Cl.Int./Int.Cl. *E04G 1/06* (2006.01),
E04G 11/48 (2006.01), *E04G 25/06* (2006.01),
E04G 7/20 (2006.01), *E04G 7/30* (2006.01),
E04G 7/32 (2006.01)
 (72) Inventeurs/Inventors:
 MEYER, ANDREAS, DE;
 MIKIC, ERZAD, DE;
 READ, ANDREW, DE;
 SPECHT, RUDOLF, DE
 (73) Propriétaire/Owner:
 PERI SE, DE
 (74) Agent: AIRD & MCBURNEY LP

(54) Titre : ELEMENT D'ECHAFAUDAGE MUNI D'UNE TETE DE SUPPORT ET ECHAFAUDAGE EQUIPE D'UN TEL
 ELEMENT D'ECHAFAUDAGE
 (54) Title: FRAME ELEMENT WITH A SUPPORT HEAD, AND BUILDING SCAFFOLD COMPRISING SUCH A FRAME
 ELEMENT



(57) **Abrégé/Abstract:**

The invention relates to a frame element (10) comprising a frame pipe (12) into which a threaded spindle (16) is partly introduced at one end. The threaded spindle (16) is guided in the frame pipe (12) by at least one spindle positioning groove (24, 26, 28), in particular multiple spindle positioning grooves (24, 26, 28). The frame pipe (12) is mechanically reinforced by the spindle positioning groove(s) (24, 26, 28) in the region of the threaded spindle (16) received in the frame pipe (12). At the same time, the maximum inclination of the threaded spindle (16) in the frame pipe (12) is reduced by the spindle positioning grooves (24, 26, 28). Overall, a force can thus be substantially more strongly applied to the frame element (10) in the direction of the longitudinal axis (23b) of the frame pipe (12). At the other end, the frame pipe (12) has at least one pin positioning groove (40, 42), in particular multiple pin positioning grooves (40, 42). Alternatively or in addition thereto, the frame pipe (12) can have at least one reinforcing groove in the region of a node point. Alternatively or in addition thereto, the frame pipe (12) can have at least one additional reinforcing groove between two node points.

Abstract:

The invention relates to a frame element (10) comprising a frame pipe (12) into which a threaded spindle (16) is partly introduced at one end. The threaded spindle (16) is guided in the frame pipe (12) by at least one spindle positioning groove (24, 26, 28), in particular multiple spindle positioning grooves (24, 26, 28). The frame pipe (12) is mechanically reinforced by the spindle positioning groove(s) (24, 26, 28) in the region of the threaded spindle (16) received in the frame pipe (12). At the same time, the maximum inclination of the threaded spindle (16) in the frame pipe (12) is reduced by the spindle positioning grooves (24, 26, 28). Overall, a force can thus be substantially more strongly applied to the frame element (10) in the direction of the longitudinal axis (23b) of the frame pipe (12). At the other end, the frame pipe (12) has at least one pin positioning groove (40, 42), in particular multiple pin positioning grooves (40, 42). Alternatively or in addition thereto, the frame pipe (12) can have at least one reinforcing groove in the region of a node point. Alternatively or in addition thereto, the frame pipe (12) can have at least one additional reinforcing groove between two node points.

Frame element with a support head, and building scaffold comprising such a frame element

5 The invention relates to a frame element for a building scaffold, the frame element having the following:

- a) A support head having a threaded spindle;
- b) a frame pipe that can be mounted vertically in the building scaffold having a spindle receiving portion on a first axial frame pipe end, the threaded spindle being introduced partially into the spindle receiving portion;
- 10 c) a spindle nut mounted to the threaded spindle, the support head introducing its vertical load into the frame pipe via the threaded spindle in the mounted state of the frame element.

15 The previously described support head of the frame element generally serves to transfer a vertical load to a building scaffold. For example, a concrete formwork can be placed or mounted onto the support head. Furthermore, the support head can be used as temporary support during refurbishing.

20 The object of the present invention is to provide a frame element that can transfer significantly more vertical load via the support head without being significantly bulkier and heavier. The object of the present invention is also to provide a building scaffold having such a frame element.

The object according to the invention is achieved by a frame element having the features as described herein and a building scaffold as described herein.

25 The object according to the invention is thus solved by a frame element for a building scaffold. The frame element has a support head having a threaded spindle. The frame element also has a frame pipe having a spindle receiving portion. The threaded spindle is partially introduced into the spindle receiving portion. The spindle receiving portion is

on a first axial end of the frame pipe. A spindle nut is mounted to the threaded spindle in such a way that the support head introduces its load into the frame pipe via the threaded spindle in the mounted vertical state of the frame element. The spindle receiving portion has a first spindle positioning nut that reduces the inner diameter of
5 the frame pipe.

The first spindle positioning groove significantly improves the vertical load bearing capacity of the frame element without considerably increasing the weight of the frame element. The first spindle positioning groove increases the load bearing capacity of the frame element in two respects: On the one hand, the solidity of the frame pipe is
10 increased in the region of the first spindle positioning groove due to the configuration of the first spindle positioning groove. On the other hand, the threaded spindle is oriented better in the frame pipe thanks to the reduced diameter of the frame pipe on the first spindle positioning groove. Overall, this results in the significantly improved suitability of the frame element for vertical load transfer.

15 The threaded spindle is preferably oriented as centered as possible in the frame pipe by the spindle positioning groove, a clearance fit being present between the threaded spindle and frame pipe for introducing the threaded spindle into the frame pipe. The longitudinal axis of the threaded spindle has the angle β relative to the longitudinal axis of the frame pipe, the angle β being less than 1° , in particular less than 0.8° , preferably
20 less than 0.7° . As a result, the vertical load is guided into the frame pipe as centrally as possible to keep the moments occurring in the building scaffold to a minimum.

The first spindle positioning groove can extend parallel to the longitudinal axis of the frame pipe. At least three grooves distributed across the circumference of the frame pipe are preferably provided for orienting the threaded spindle. In a preferred
25 embodiment of the first spindle positioning groove, however, it extends in the circumferential direction of the frame pipe. The first spindle positioning groove can be designed to be discontinuous or circumferential in the circumferential direction of the frame pipe.

Particularly effective centering of the threaded spindle in the frame pipe is done when the axial spacing of the first spindle positioning groove from the first axial frame pipe end is smaller than the inner diameter of the spindle receiving portion.

5 More preferably, the spindle receiving portion preferably has a second spindle positioning groove. The second spindle positioning groove is axially spaced apart from the first spindle positioning groove and reduces the inner diameter of the frame pipe. Due to the second spindle positioning groove, the orientation of the threaded spindle in the frame pipe is defined by at least two spindle positioning grooves that are spaced axially apart from each other, as a result of which the orientation, in particular the
10 centering, of the threaded spindle is particularly precise.

The second spindle positioning groove can extend parallel to the longitudinal axis of the frame pipe. At least three grooves distributed across the circumference of the frame pipe are preferably provided for orienting the threaded spindle. As an alternative to this, the second spindle positioning groove can extend in the circumferential direction of the
15 frame pipe. The second spindle positioning groove can be designed to be discontinuous or circumferential in the circumferential direction of the frame pipe.

In a more preferred embodiment of the invention, the spindle receiving portion has a third spindle positioning groove. The third spindle positioning groove is spaced axially further away from the first spindle positioning groove than the second spindle
20 positioning groove. The third spindle positioning nut reduces the inner diameter of the frame pipe. The third spindle positioning groove improves the orientation, in particular the centering, of the threaded spindle in the frame pipe.

The third spindle positioning groove can extend parallel to the longitudinal axis of the frame pipe. At least three grooves distributed across the circumference of the frame
25 pipe are preferably provided for orienting the threaded spindle. As an alternative to this, the third spindle positioning groove can extend in the circumferential direction of the frame pipe. The third spindle positioning nut groove can be designed to be discontinuous or circumferential in the circumferential direction of the frame pipe.

The third spindle positioning groove is preferably spaced less axially far apart from the second spindle positioning groove than the second spindle positioning groove is from the first spindle positioning groove.

5 Particularly preferably, the second spindle positioning groove and/or the third spindle positioning groove reduces the inner diameter of the frame pipe just as much as the first spindle positioning groove. The radial play of the threaded spindle in the frame pipe is reduced significantly as a result of this, it nevertheless remaining easy to introduce the threaded spindle into the frame pipe.

10 On its second axial frame pipe end, which is opposite the first axial frame pipe end, the frame pipe can have a pin receiving portion into which a pin of a further frame element can be introduced. The pin receiving portion can have a first pin positioning groove that reduces the inner diameter of the frame pipe. The first pin positioning groove mechanically reinforces the frame pipe in the region of the pin receiving portion.

15 The first pin positioning groove can extend parallel to the longitudinal axis of the frame pipe. At least three grooves distributed across the circumference of the frame pipe are preferably provided for orienting the threaded spindle. As an alternative to this, the first pin positioning groove can extend in the circumferential direction of the frame pipe. The first pin positioning groove can be designed to be discontinuous or circumferential in the circumferential direction of the frame pipe.

20 The axial spacing of the first pin positioning groove from the second axial frame pipe end is preferably smaller than the inner diameter of the first pin positioning groove.

25 More preferably, the pin receiving portion has a second pin positioning groove that is axially spaced apart from the first pin positioning groove and reduces the inner diameter of the frame pipe. As a result, the pin of a further frame element is centered at two pin positioning grooves in the pin receiving portion that are spaced axially apart from each other.

The second pin positioning groove can extend parallel to the longitudinal axis of the

frame pipe. At least three grooves distributed across the circumference of the frame pipe are preferably provided for orienting the threaded spindle. As an alternative to this, the second pin positioning groove can extend in the circumferential direction of the frame pipe. The second pin positioning nut groove can be designed to be discontinuous
5 or circumferential in the circumferential direction of the frame pipe.

In a more preferred embodiment of the frame element, the frame pipe has a node point on which

- a) a crossbar of the frame element is connected to the frame pipe, or
- b) a coupling point is installed for connecting a crossbar,

10 the frame pipe having a first reinforcing groove in the region of the node point. The first reinforcing groove is spaced less than 15 cm from the node point in a first axial direction and reduces the inner diameter of the frame pipe or increases the outer diameter of the frame pipe. Due to the first reinforcing groove, the frame element is reinforced in an area in which it is loaded particularly heavily, namely in the region of the node point.
15 Due to the first reinforcing groove, the frame pipe offers a higher resistance and moment of inertia in the region of the pressure point of the crossbar. The coupling point can be designed in the form of a rosette for connecting a crossbar.

More preferably, the frame pipe has a further reinforcing groove in the region of the node point that is spaced less than 15 cm from the node point in a second axial
20 direction and reduces the inner diameter of the frame pipe or increases the outer diameter of the frame pipe. The second axial direction is opposite the first axial direction. In other words, the node point is reinforced by a further reinforcing groove in both axial directions by one reinforcing groove in each case.

The spindle positioning groove(s) and the reinforcing groove(s) preferably reduces the
25 inner diameter of the frame pipe to the same extent.

The object according to the invention is also solved by a building scaffold having a previously described frame element.

Further features and advantages of the invention are presented in the following detailed description of multiple exemplary embodiments of the invention, in the claims and based on the figures of the drawing that shows details that are essential to the invention.

5 The features shown in the drawing are depicted in such a way that the special features according to the invention can be made clearly visible. The various features can each be realized in variants of the invention individually or in groups in any combination.

Shown are:

Figure 1 a sectional view of a frame element from the prior art;

Figure 2 a sectional view of a frame element according to the invention;

10 Figure 3 a top view of a node point of a frame element according to the invention; and

Figure 4 a perspective view of a building scaffold according to the invention.

Figure 1 shows a frame element **10** according to the prior art. Frame element **10** has a frame pipe **12**. A spindle receiving portion **14** is designed in frame pipe **12**. A threaded spindle **16** is introduced into spindle receiving portion **14**. Threaded spindle **16** has an external thread **18**. Known frame element **10** also has a spindle nut **20**. Spindle nut **20** has an internal thread **22** with which spindle nut **20** is attached to external thread **18** of threaded spindle **16**.
15

Spindle receiving portion **14** has the same inner diameter along the entire axial direction. Threaded spindle **16**, which is supported axially via spindle nut **20** on frame pipe **12**, has a position skewed at angle β . More specifically, longitudinal axis **23a** of threaded spindle **16** is inclined by angle β relative to longitudinal axis **23b** of frame pipe **12**. The angle β is typically 1.29° .
20

In contrast to figure 1, **figure 2** shows a frame element **10** according to the invention.

According to figure 2, frame element 10 has a frame pipe 12 with a spindle receiving portion 14. Furthermore, frame element 10 has a threaded spindle 16 on which a spindle nut 20 is arranged. Spindle receiving portion 14 has a first spindle positioning groove **24**, a second spindle positioning groove **26** and a third spindle positioning groove **28**. Spindle positioning grooves 24, 26, 28 define the effective inner diameter of spindle receiving portion 14 for threaded spindle 16. Due to spindle positioning grooves 24, 26, 28, threaded spindle 16 is arranged in frame pipe 12 at a much smaller inclination. The angle β between longitudinal axis 23a of threaded spindle 16 and longitudinal axis 23b of frame pipe 12 is, in particular, less than 0.8° , preferably less than 0.7° . In comparison to frame element 10 according to figure 1, the vertical load bearing capacity of frame element 10 is increased by approximately 10% as a result. In addition thereto, the spindle receiving portion is mechanically reinforced against kinking by spindle positioning grooves 24, 26, 28.

Figure 2 depicts a further frame element **30** (dashed lines) whose pin **32** can be introduced into frame pipe 12.

Frame pipe 12 thus has a first axial frame pipe end **34** into which threaded spindle 16 can be introduced. Furthermore, frame pipe 12 has a second axial frame pipe end **36** into which pin 32 of further frame element 30 can be introduced. A pin receiving portion **38** for receiving pin 32 in frame pipe 12 is designed on second axial frame pipe end 36. A mechanical reinforcement of pin receiving portion 38 as well as improved centering of pin 32 is done by a first pin positioning groove **40** and a second pin positioning groove **42**.

Figure 3 shows a further frame element according to the invention 10. Frame element 10 has a node point **44** having a coupling point **46**. In the present case, coupling point 46 is designed in the form of a rosette. Crossbars **48, 50** are arranged at coupling point 46.

It is evident from figure 3 that frame pipe 12 has a first reinforcing groove **54** which is designed to be spaced apart from coupling point 46 in frame pipe 12 in a first axial

direction **56**. A second reinforcing groove **58** is designed in frame pipe 12 in first axial direction 56 at a distance from coupling point 46. Shoulders **60, 62** of crossbars 48, 50 are in the region of frame pipe 12 between first reinforcing groove 54 and second reinforcing groove 58 on frame pipe 12. First reinforcing groove 54 and second reinforcing groove 58 thus form an area of frame pipe 12 that is mechanically especially stable in which, in particular, the mechanical stability against buckling of frame pipe 12 is very high.

Frame pipe 12 has a further reinforcing groove **64**. Further reinforcing groove 64 is spaced apart from coupling point 46 in a second axial direction **66**. First axial direction 56 and second axial direction 66 run along longitudinal axis 23b of frame pipe 12, second axial direction 66 being opposite first axial direction 56. Further reinforcing groove 64 allows insertion tabs **68, 70** of crossbars 48, 50 to be pressed mechanically against frame pipe 12 particularly firmly without resulting in the plastic deformation of frame pipe 12 when crossbar 48 and/or 50 is loaded.

Alternatively or in addition to described reinforcing grooves 54, 58, 64, frame element 10 can be designed with at least one additional reinforcing groove **72** in frame pipe 12 between axially adjacent coupling points, of which only one coupling point 46 is depicted in figure 3.

Figure 4 shows a building scaffold **74** having multiple frame elements, of which only a first frame element 10 is provided with a reference character in figure 4 for the sake of clarity. By way of example, frame element 10 has a node point 44 on which—likewise by way of example—a crossbar 48 is arranged. Because of the small depiction of building scaffold 74, no groove according to the invention is visible in figure 4. For the removal of a load, frame element 10 has a support head **76**.

When viewing all figures of the drawing together, the invention relates, in summary, to a frame element 10 comprising a frame pipe 12 into which a threaded spindle 16 is partly introduced at one end. Threaded spindle 16 is guided in frame pipe 12 by at least one spindle positioning groove 24, 26, 28, in particular multiple spindle positioning grooves

24, 26, 28. Frame pipe 12 is mechanically reinforced by spindle positioning groove(s) 24, 26, 28 in the region of threaded spindle 16 received in frame pipe 12. At the same time, the maximum inclination of threaded spindle 16 in frame pipe 12 is reduced by spindle positioning groove(s) 24, 26, 28. Overall, a force can thus be substantially more strongly applied to frame element 10 in the direction of longitudinal axis 23b of frame pipe 12. At the other end, frame pipe 12 can have at least one pin positioning groove 40, 42, in particular multiple pin positioning grooves 40, 42. Alternatively or in addition thereto, frame pipe 12 can have at least one reinforcing groove 54, 58, 64 in the region of a node point 44. Alternatively or in addition thereto, frame pipe 12 can have at least one additional reinforcing groove 72 between two node points 44.

Claims

1. A frame element for a building scaffold, the frame element having the following:
 - a) a support head having a threaded spindle;
 - b) a frame pipe that can be mounted vertically in the building scaffold, the frame pipe having a spindle receiving portion on a first axial frame pipe end, the threaded spindle being introduced partially into the spindle receiving portion;
 - c) a spindle nut mounted to the threaded spindle, the support head introducing its vertical load into the frame pipe via the threaded spindle in a mounted state of the frame element;
wherein the spindle receiving portion has a first spindle positioning groove that reduces an inner diameter of frame pipe,
wherein the spindle receiving portion comprises a second spindle positioning groove that is spaced axially from the first spindle positioning groove and reduces the inner diameter of the frame pipe, and
wherein the second spindle positioning groove reduces the inner diameter of the frame pipe precisely as far as the first spindle positioning groove.
2. The frame element according to claim 1, wherein the first spindle positioning groove radially centers the threaded spindle in the frame pipe in such a way that

a longitudinal axis of the threaded spindle is inclined at an angle β relative to the longitudinal axis of the frame pipe, the angle β being less than 1° .

3. The frame element according to claim 1 or 2, wherein the first spindle positioning groove extends in a circumferential direction of the frame pipe, the first spindle positioning groove is discontinuous or circumferential in the circumferential direction of the frame pipe.
4. The frame element according to any one of claims 1 to 3, wherein an axial spacing of the first spindle positioning groove from the first axial frame pipe end is smaller than the inner diameter of the spindle receiving portion.
5. The frame element according to any one of claims 1 to 4, wherein the spindle receiving portion has a third spindle positioning groove that is axially further spaced from the first spindle positioning groove than the second spindle positioning groove and reduces the inner diameter of the frame pipe.
6. The frame element according to claim 5, wherein the third spindle positioning groove reduces the inner diameter of the frame tube precisely as far as the first spindle positioning groove.

7. The frame element according to claim 5 or 6, wherein the third spindle positioning groove is axially spaced not as far from the second spindle positioning groove as the second spindle positioning groove is from the first spindle positioning groove.
8. The frame element according to any one of claims 1 to 7, wherein the frame pipe has a pin receiving portion at its second axial frame pipe end into which a pin of a further frame element can be introduced, the pin receiving portion having a first pin positioning groove that reduces the inner diameter of the frame pipe.
9. The frame element according to claim 8, wherein the pin receiving portion has a second pin positioning groove that is axially spaced apart from the first pin positioning groove and reduces the inner diameter of the frame pipe.
10. The frame element according to any one of claims to 1 to 9, wherein the frame pipe has a node point on which
 - a) a crossbar of the frame element is connected to the frame pipe, or
 - b) a coupling point is embodied so as to connect to a crossbar,the frame pipe having a first reinforcing groove in a region of the node point that is spaced less than 15 cm from the node point in a first axial direction and

- i. reduces the inner diameter of frame pipe or
 - ii. increases an outer diameter of frame pipe.

- 11. The frame element according to claim 10, wherein the coupling point is in the form of a rosette.

- 12. The frame element according to claim 10 or 11, wherein the frame pipe has a further reinforcing nut in the region of the node point that is spaced less than 15 cm from the node point in a second axial direction opposite the first axial direction and
 - i. reduces the inner diameter of frame pipe or
 - ii. increases the outer diameter of frame pipe.

- 13. A building scaffold having a frame element according to any one of claims 1 to 12.

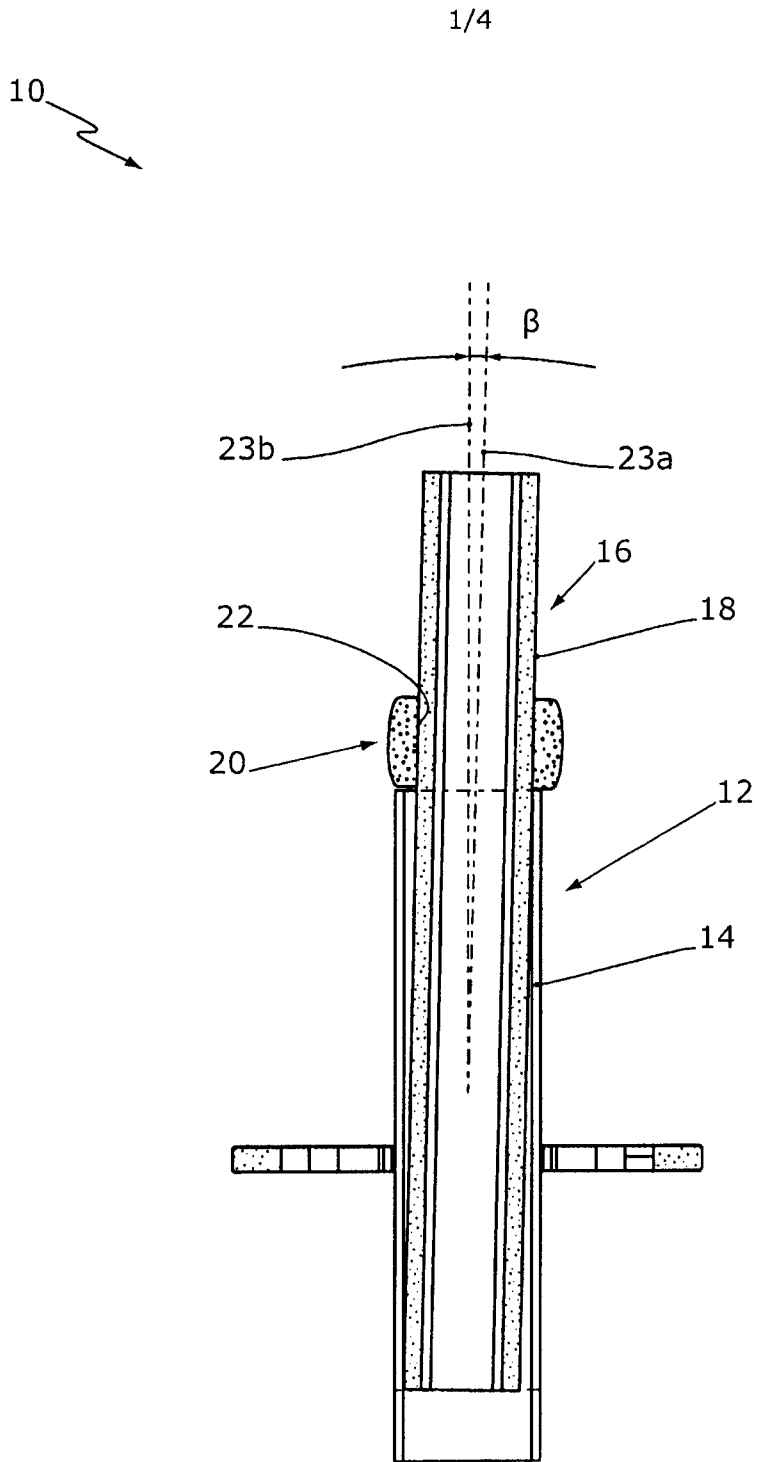

Fig. 1 Prior Art

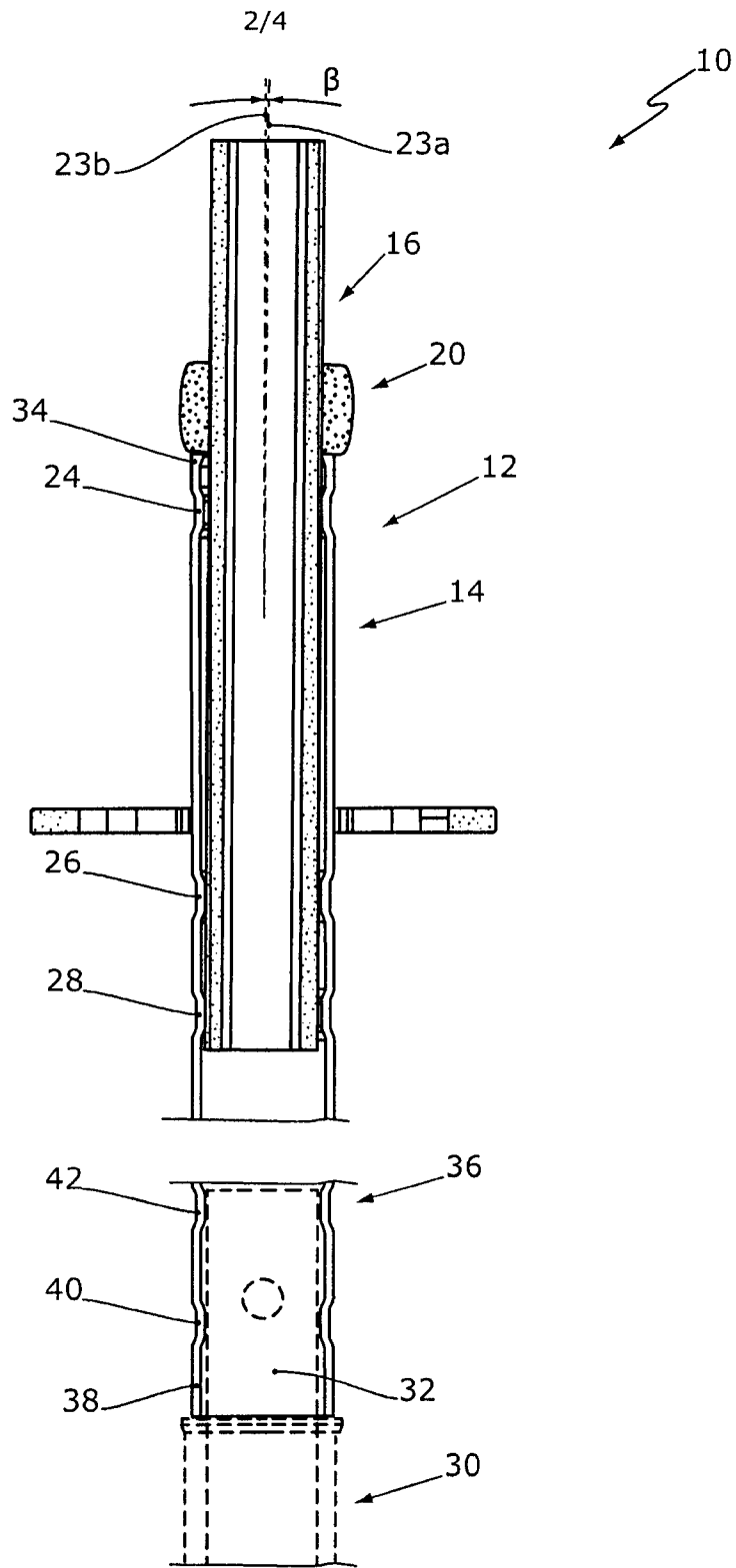

Fig. 2

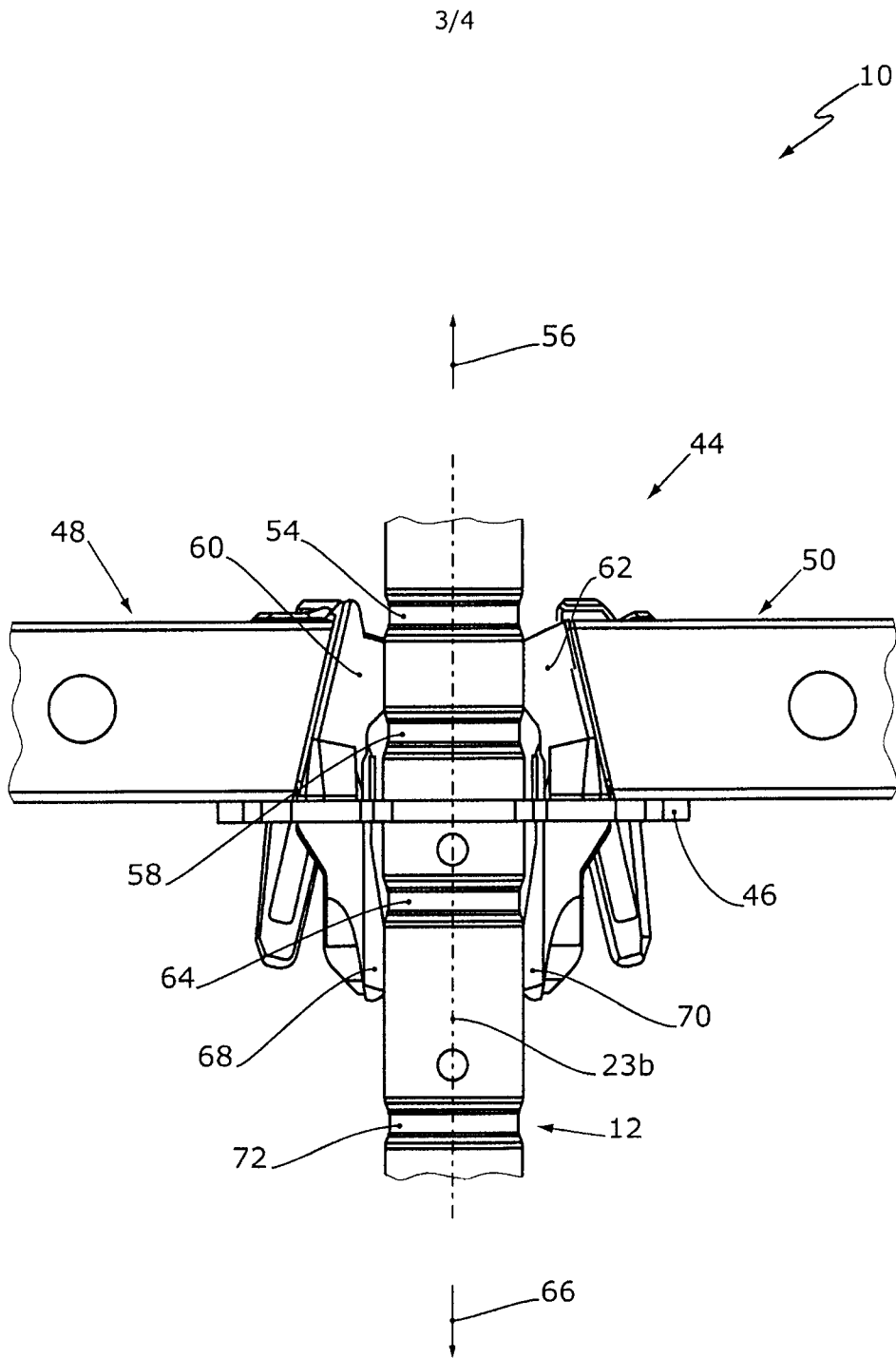

Fig. 3

4/4

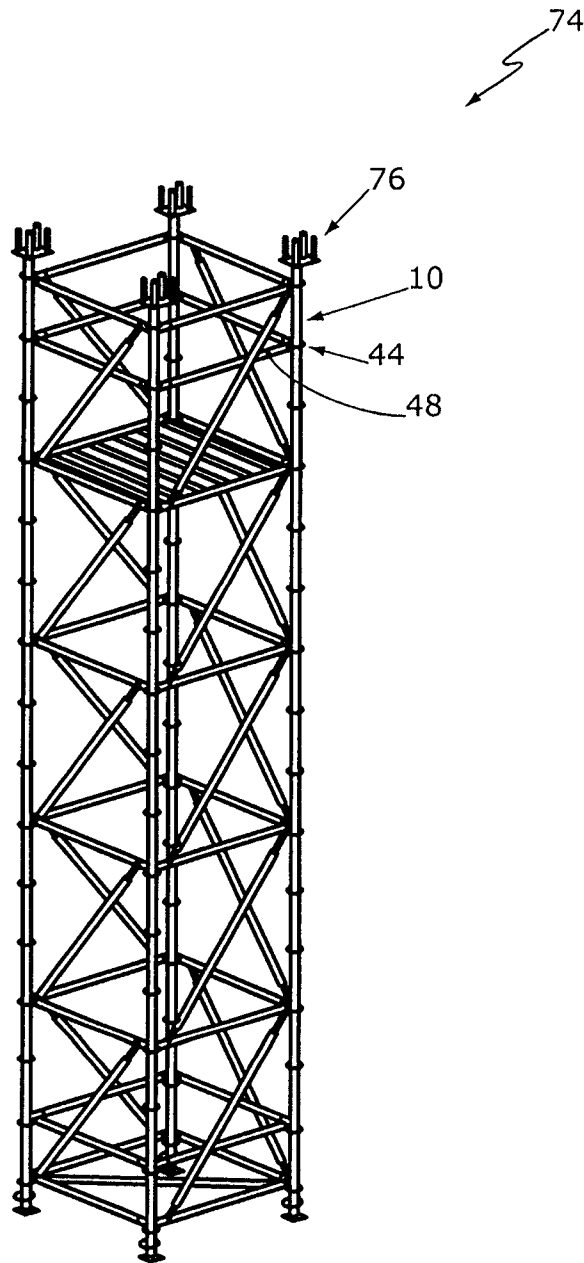

Fig. 4

