

(19) World Intellectual Property Organization  
International Bureau



(43) International Publication Date  
2 December 2010 (02.12.2010)

PCT

(10) International Publication Number  
**WO 2010/138927 A2**

(51) International Patent Classification:  
*G01N 21/17* (2006.01) *G01B 9/02* (2006.01)

B. [US/US]; 400 Chesapeake Drive, Redwood City, CA 94063 (US).

(21) International Application Number:  
PCT/US2010/036743

(74) Agents: **SHOOP, Richard, D.** et al.; SHAY GLENN LLP, 2755 Campus Drive, Suite 210, San Mateo, CA 94403 (US).

(22) International Filing Date:  
28 May 2010 (28.05.2010)

(81) Designated States (*unless otherwise indicated, for every kind of national protection available*): AE, AG, AL, AM, AO, AT, AU, AZ, BA, BB, BG, BH, BR, BW, BY, BZ, CA, CH, CL, CN, CO, CR, CU, CZ, DE, DK, DM, DO, DZ, EC, EE, EG, ES, FI, GB, GD, GE, GH, GM, GT, HN, HR, HU, ID, IL, IN, IS, JP, KE, KG, KM, KN, KP, KR, KZ, LA, LC, LK, LR, LS, LT, LU, LY, MA, MD, ME, MG, MK, MN, MW, MX, MY, MZ, NA, NG, NI, NO, NZ, OM, PE, PG, PH, PL, PT, RO, RS, RU, SC, SD, SE, SG, SK, SL, SM, ST, SV, SY, TH, TJ, TM, TN, TR, TT, TZ, UA, UG, US, UZ, VC, VN, ZA, ZM, ZW.

(25) Filing Language: English

(26) Publication Language: English

(30) Priority Data:  
61/182,061 28 May 2009 (28.05.2009) US  
61/222,238 1 July 2009 (01.07.2009) US  
61/258,064 4 November 2009 (04.11.2009) US

(71) Applicant (*for all designated States except US*):  
**AVINGER, INC.** [US/US]; 400 Chesapeake Drive, Redwood City, CA 94063 (US).

(72) Inventors; and

(75) Inventors/Applicants (*for US only*): **BLACK, John, F.** [US/US]; 400 Chesapeake Drive, Redwood City, CA 94063 (US). **SPENCER, Maegan, K.** [US/US]; 400 Chesapeake Drive, Redwood City, CA 94063 (US). **ZUNG, Michael** [US/US]; 400 Chesapeake Drive, Redwood City, CA 94063 (US). **MCNALL, Charles** [US/US]; 400 Chesapeake Drive, Redwood City, CA 94063 (US). **LUMABAS, Evangeline** [US/US]; 400 Chesapeake Drive, Redwood City, CA 94063 (US). **ROSENTHAL, Michael, M.** [US/US]; 400 Chesapeake Drive, Redwood City, CA 94063 (US). **SIMPSON, John,**

(84) Designated States (*unless otherwise indicated, for every kind of regional protection available*): ARIPO (BW, GH, GM, KE, LR, LS, MW, MZ, NA, SD, SL, SZ, TZ, UG, ZM, ZW), Eurasian (AM, AZ, BY, KG, KZ, MD, RU, TJ, TM), European (AL, AT, BE, BG, CH, CY, CZ, DE, DK, EE, ES, FI, FR, GB, GR, HR, HU, IE, IS, IT, LT, LU, LV, MC, MK, MT, NL, NO, PL, PT, RO, SE, SI, SK, SM, TR), OAPI (BF, BJ, CF, CG, CI, CM, GA, GN, GQ, GW, ML, MR, NE, SN, TD, TG).

Published:

— *without international search report and to be republished upon receipt of that report (Rule 48.2(g))*



WO 2010/138927 A2

(54) Title: OPTICAL COHERENCE TOMOGRAPHY FOR BIOLOGICAL IMAGING

(57) Abstract: Described herein are catheters for use with Optical Coherence Tomography (OCT) that include an optical fiber core having a first refractive index and an interface medium having a second refractive index, where the first and second refractive indexes are mismatched such that receiving electronics configured to receive optical radiation reflected from the reference interface and the target operate in a total noise range that is within 5 dB of the shot noise limit. These OCT catheters may include a silicon die mirror having a reflective coating that is embedded in the interface medium. The optical fiber can be fixed at just the distal end of the catheter, and may be managed within a handle that is attached to the proximal end of the catheter body, and is configured to allow rotation of the both catheter body and the optical fiber relative to the handle.

**OPTICAL COHERENCE TOMOGRAPHY FOR BIOLOGICAL IMAGING****CROSS REFERENCE TO RELATED APPLICATIONS**

[0001] This application claims the benefit of U.S. Provisional Application No. 61/182,061, filed May 28, 2009, U.S. Provisional Application No. 61/258,064, filed November 4, 2009, and U.S. Provisional Application No. 61/222,238, filed July 1, 2009. The disclosures of these applications are incorporated herein by reference in their entirety.

**INCORPORATION BY REFERENCE**

[0002] All publications and patent applications mentioned in this specification are herein incorporated by reference in their entirety to the same extent as if each individual publication or patent application was specifically and individually indicated to be incorporated by reference.

**FIELD OF THE INVENTION**

[0003] Described herein are imaging devices and systems for use in biological probes. In particular, described herein are catheter-based imaging systems using Optical Coherence Tomography (OCT).

**BACKGROUND OF THE INVENTION**

[0004] In cardiovascular surgery, as well as other medical applications, there is frequently a need to extend very thin (few millimeter diameter), long (30 -150+ cm) and sterile catheters into thin-walled (e.g., 1 – 1.5 millimeter wall thickness) biological lumens, including blood vessels such as arteries and veins.

[0005] A number of vascular diseases, such as coronary artery disease and peripheral vascular disease, are caused by the build-up of atherosclerotic deposits (plaque) in the arteries, which limit blood flow to the tissues that are supplied by that particular artery. Disorders caused by occluded body vessels, including coronary artery disease (CAD) and peripheral artery disease (PAD) may be debilitating and life-threatening. Chronic Total Occlusion (CTO) can result in limb gangrene, requiring amputation, and may lead to other complications and eventually death. Increasingly, treatment of such blockages may include interventional procedures in which a guidewire is inserted into the diseased artery and threaded to the blocked region. There the blockage may be either expanded into a more open position, for example, by pressure from an inflated catheter balloon (e.g., balloon angioplasty), and/or the blocked region may be held open by a stent. Treatment of such blockages can also include using a catheter to surgically remove the plaque from the inside of the artery (e.g., an atherectomy).

[0006] When the artery is totally blocked by plaque, it is extremely difficult, and potentially dangerous to force the guidewire through the occlusion. An obstruction or plaque may be composed of relatively tough fibrous material, often including hard calcium deposits. Forcing a

guidewire or catheter past such obstructions may cause the guidewire to puncture the walls of the vessel (e.g., artery) or cause it to enter the layers forming the artery, further damaging the tissue. Thus, there remains a need for guidewire positioning devices that can effectively traverse occluded vessels, and particularly chronically occluded vessels. Such devices would enable  
5 positioning of a guidewire and therefore enable positioning of stents and other devices, leading to improved patient outcomes and a reduction in patient morbidity and mortality.

[0007] Moreover, there is medical interest in equipping catheter-based cardiovascular catheters with sensors that can help direct atherectomy and other surgical procedures. For example, it would be useful to have sensors that can give the surgeon immediate visual feedback  
10 as to whether a particular tissue is diseased and/or how far away the cutting portion of a catheter is from the boundary of a particular blood vessel layer to minimize the risk of accidental damage. Conventional radiological imaging methods and ultrasound imaging systems have been attempted for such surgical procedures. However, neither ultrasound nor radiological imaging methods have enough resolution to help guide the operation of the catheter over the critical last  
15 fraction of a millimeter between the interior of a blood vessel and the exterior of the blood vessel. Moreover, standard radiological techniques cannot easily discriminate between healthy tissue and diseased tissue unless the tissue has become heavily calcified. Further, the components of an ultrasound system are generally too large to implement in small dimensions.

[0008] Optical Coherence Tomography (OCT) has been proposed as one technique that may  
20 be particularly helpful for imaging regions of tissue, including within a body lumen such as a blood vessel. At a basic level, OCT relies on the fact that light traveling from a source and scattering from more distant objects takes longer to travel back than light scattering from nearby objects. Due to the wave nature of light, very small timing differences caused by light signals traveling different distances on the micron scale can cause constructive or destructive  
25 interference with reference light signals. OCT systems measure the resulting interference to obtain an image of the target. Unfortunately, however it has thus far proven difficult to provide stable and reliable OCT systems for use in a catheter. A typical OCT system requires one or more interferometers to distinguish the signal from the applied light. In addition, most known OCT systems, when applied to catheters, include a fiber that is rotated (often at high rates)  
30 within the catheter in order to scan around a lumen. These systems typically require relatively high power operation, since the many components necessary for rotating and managing the OCT pathway (e.g., fiber) result in optical losses.

[0009] Thus, there is a need for efficient and robust OCT systems that are compatible with catheter applications and uses. Described herein are enhanced Optical Coherence Tomography  
35 (OCT) systems that that overcome many of the problems described above.

[00010] Referring to FIG. 1, a typical OCT device includes a target arm and a reference arm to generate a reference signal. In order to provide the interference reference signal, the OCT device will split an illuminating light signal from the source in two equal or unequal parts, send part of the illuminating light to the target of interest through one target optical “target arm” and send the other part of the illuminating light down a separate reference arm. Light from the separate reference arm reflects off of a mirror, and then returns and interferes with the scattered light that is returning from the target optical arm after bouncing off of the target. In a traditional OCT device, the reference arm length is engineered to be exactly the same length as the target arm so that the interference effect is maximized. The resulting interference between the two beams creates interference effects known as fringes that can be used to measure the relative reflectivity of various layers of the target. Using this information, an image of the object can be generated.

[00011] By contrast to the more established applications for OCT, cardiovascular catheters, which are intended for one-time use in blood vessel environments, must be of the highest level of sterility. To obtain such sterility, cardiovascular catheters are typically produced as low-cost disposable items that can be factory sterilized. During a medical procedure, such a catheter is typically removed from the factory sterile container. The proximal end of the catheter is connected to equipment needed to control the catheter (which in this case would also include the link to the OCT engine used to drive any OCT optical fiber in the catheter), and the distal tip is immediately inserted into the patient’s body. The catheter is then discarded once the procedure is complete.

[00012] Producing low-cost disposable catheters can be difficult as a result of the need for precise reference arm matching and expensive optics. Thus, there is also a need for a low-cost OCT catheter.

## 25 SUMMARY OF THE INVENTION

[00013] Described herein are OCT catheter, catheter systems, and methods of using and manufacturing them. In general, the OCT catheters and systems described herein are appropriate for use in a patient in order to visualize the internal structures within a lumen of the body in real time. These systems may allow control and navigation of the catheter, including navigation around and through complex anatomy such as bifurcations, ostials, regions of tortuosity, and the like. Further, the real-time and efficient imaging, as well as the control of the imaging system may allow a reduction in procedure time and improvements for long- and short-term outcomes.

[00014] In general, a system for optical coherence tomography may include a source of optical radiation, an optical fiber, receiving electronics, an interface medium, and a processor. Typically, the optical fiber has a core providing a common path for optical radiation reflected

from a reference interface and a target. The core has a first refractive index. As described herein, the receiving electronics are configured to receive the optical radiation reflected from the reference interface and the target. The interface medium is at the reference interface and in optical contact with the optical fiber. The interface medium has a second refractive index. The first refractive index and the second refractive index are mismatched such that the receiving electronics operate in a total noise range that is within 5 dB of the shot noise limit. The processor generates an image of the target based upon the optical radiation received by the receiving electronics.

**[00015]** This and other embodiments may include one or more of the following features. The first refractive index and the second refractive index can be mismatched such that the receiving electronics operate in a total noise range that is within 3 dB of the shot noise limit. The first refractive index and the second refractive index can be mismatched such that the receiving electronics operate in a total noise range that is within 2 dB of the shot noise limit. The source of optical radiation can be a swept-frequency source.

**[00016]** The system can further include a mirror in the interface medium, and the mirror can be configured to reflect the optical radiation from the optical fiber to the target. The mirror can include a gold-coated silicon die. The interface medium can be a solid transparent medium. The interface medium can be in optical contact with a distal end of the core.

**[00017]** The system can further include a directional element configured to relay the optical radiation from the source to a distal end of the core.

**[00018]** The first refractive index  $n_1$  and the second refractive index  $n_2$  can be mismatched such that:

$$\frac{P_{out}}{P_{in}} = \left( \frac{n_1 - n_2}{n_1 + n_2} \right)$$

**[00019]** wherein  $P_{in}$  is the power of the optical radiation at the distal end of the optical fiber prior to entering the interface medium, and wherein  $P_{out}$  is the power of the optical radiation reflected from the reference interface such that the receiving electronics operate in a total noise range that is within 5 dB of the shot noise limit. In general, a catheter for use with optical coherence tomography includes an elongate catheter body, an optical fiber in the elongate catheter body, and an interface medium. The optical fiber has a core providing a common path for optical radiation reflected from a reference interface and a target. The core has a first refractive index. The interface medium is in optical contact with the optical fiber. The interface medium has a second refractive index. The first refractive index and the second refractive index are mismatched such that receiving electronics configured to receive optical radiation reflected

from the reference interface and the target operate in a total noise range that is within 5 dB of the shot noise limit.

**[00020]** This and other embodiments may include one or more of the following features.

The first refractive index and the second refractive index can be mismatched such that the receiving electronics operate in a total noise range that is within 3 dB of the shot noise limit.

The first refractive index and the second refractive index can be mismatched such that the receiving electronics operate in a total noise range that is within 2 dB of the shot noise limit.

**[00021]** The system can further include a mirror in the interface medium. The mirror can be configured to reflect the optical radiation from the optical fiber to the target. The mirror can include a gold-coated silicon die. The interface medium can be a solid transparent medium. The interface medium can be in optical contact with a distal end of the core.

**[00022]** The first refractive index  $n_1$  and the second refractive index  $n_2$  can be mismatched such that:

$$\frac{P_{out}}{P_{in}} = \left( \frac{n_1 - n_2}{n_1 + n_2} \right)$$

**[00023]** wherein  $P_{in}$  is the power of the optical radiation at the distal end of the optical fiber prior to entering the interface medium, and wherein  $P_{out}$  is the power of the optical radiation reflected from the reference interface such that the receiving electronics operate in a total noise range that is within 5 dB of the shot noise limit.

**[00024]** In general, a method of performing optical coherence tomography includes: transmitting optical radiation from a source through an optical fiber having a core, the core having a first refractive index; transmitting the optical radiation from the optical fiber through an interface medium, wherein the interface medium is in optical contact with the optical fiber, the interface medium having a second refractive index; transmitting optical radiation reflected from the target and reflected from a reference interface along a common path in the optical fiber to a detector; receiving the reflected optical radiation at receiving electronics, wherein the first refractive index and the second refractive index are mismatched such that the receiving electronics operate in a total noise range that is within 5 dB of the shot noise limit; and generating an image of the target based upon the reflected optical radiation received by the receiving electronics.

**[00025]** This and other embodiments may include one or more of the following features.

The first refractive index and the second refractive index can be mismatched such that the receiving electronics operate in a total noise range that is within 3 dB of the shot noise limit.

The first refractive index and the second refractive index can be mismatched such that the receiving electronics operate in a total noise range that is within 2 dB of the shot noise limit.

[00026] Transmitting optical radiation can include transmitting optical radiation comprises transmitting swept-source radiation. Transmitting optical radiation from the optical fiber through the interface medium further can include transmitting the optical radiation from the optical fiber to a mirror in the interface medium.

5 [00027] In general, a system for optical coherence tomography includes a source of optical radiation, an optical fiber providing a common path for optical radiation reflected from a reference and a target, a detector to receive the optical radiation reflected from the reference and the target, an interface medium at the reference interface and in optical contact with the distal end of the optical fiber, a mirror in the embedding medium, and a processor to generate an image  
10 of the target based upon the optical radiation received by the detector. The mirror includes a silicon die having a reflective coating.

[00028] This and other embodiments may include one or more of the following features. The reflective coating can be metallic. The metallic coating can be gold. The reflective coating may be at least  $\frac{\lambda_{\min}}{2\pi}$  Å thick where  $\lambda_{\min}$  is the wavelength of light in the optical fiber. The  
15 metallic coating can be about 2,800 Å thick.

[00029] The system can further include an adhesion layer between the silicon die and the reflective coating. The adhesion layer can include nickel, titanium, or chromium. The adhesion layer can be between 50 Å and 200 Å thick. The adhesion layer can be about 100 Å thick. The interface medium can include an adhesive.

20 [00030] The mirror can be at least 95% reflective, such as at least 98% reflective. The interface medium can be a solid transparent medium. The source of optical radiation can be configured to provide swept-source radiation.

[00031] In general, a catheter for use with optical coherence tomography includes an elongate catheter body, an optical fiber in the elongate catheter body, an interface medium, and a  
25 mirror in the interface medium. The optical fiber provides a common path for optical radiation reflected from a reference interface and a target. The interface medium is at the reference interface and in optical contact with a distal end of the optical fiber. The mirror includes a silicon die having a reflective coating.

[00032] This and other embodiments may include one or more of the following features.  
30 The interface medium can include an adhesive. The reflective coating can be metallic. The metallic coating can be gold. The reflective coating can be at least  $\frac{\lambda_{\min}}{2\pi}$  Å thick where  $\lambda_{\min}$  is the wavelength of light in the optical fiber. The reflective coating can be about 2,800 Å thick.

**[00033]** The catheter can further include an adhesion layer between the silicon die and the reflective coating. The adhesion layer can be nickel, titanium, or chromium. The adhesion layer can be between 50 Å and 200 Å thick. The adhesion layer can be about 100 Å thick. The mirror can be at least 95% reflective, such as at least 98% reflective.

5 **[00034]** In general, a method of performing optical coherence tomography includes transmitting optical radiation from a source through an optical fiber; transmitting the optical radiation from the optical fiber to a mirror embedded in an interface medium, wherein the mirror comprises a silicon die having a reflective coating, and wherein the interface medium is in optical contact with a distal end of a core of the optical fiber; reflecting the optical radiation from  
10 the mirror to a target; reflecting the optical radiation from a reference interface, the reference interface between the optical fiber and the interface medium; transmitting optical radiation reflected from the target and reflected from the reference interface along a common path in the optical fiber to a detector; receiving the reflected optical radiation at a detector; and generating an image of the target based upon the reflected optical radiation received by the detector.

15 **[00035]** This and other embodiments may include one or more of the following features. Transmitting optical radiation can include transmitting swept-source radiation. The reflective coating can be metallic. The metallic coating can be gold. The metallic coating may be at least  $\frac{\lambda_{\min}}{2\pi}$  Å thick where  $\lambda_{\min}$  is the wavelength of light in the optical fiber. The metallic coating can be about 2,800 Å thick.

20 **[00036]** The method can further include an adhesion layer between the silicon die and the reflective coating. The adhesion layer can include nickel, titanium, or chromium. The adhesion layer can be between 50 Å and 200 Å thick. The adhesion layer can be about 100 Å thick. The mirror can be at least 95% reflective, such as at least 98% reflective.

**[00037]** In general, a system for optical coherence tomography includes a source of optical  
25 radiation, an elongate catheter body, an optical fiber, a handle attached to the proximal end of the elongate catheter body, a detector, and a processor. The optical fiber extends from a proximal end to a distal end of the elongate catheter body and can be attached to a distal end of the catheter body. The optical fiber provides a common path for optical radiation reflected from a reference and a target. The handle is configured to allow rotation of the catheter body and the  
30 optical fiber relative to the handle about a longitudinal axis of the elongate catheter body. The detector receives the optical radiation reflected from the reference and the target. The processor generates an image of the target based upon the optical radiation received by the detector.

**[00038]** This and other embodiments may include one or more of the following features. The optical fiber can be attached to the catheter body only near the distal end of the catheter



body. A distal end of the optical fiber can be embedded in a solid transparent medium. The optical fiber can be not coaxial with the elongate catheter body. The handle can include a spooling mechanism, and the spooling mechanism can be configured to spool the optical fiber as it rotates. The handle can include a rotating mechanism, wherein one rotation of the rotating  
5 mechanism causes the catheter body and optical fiber to rotate about the longitudinal axis more than one time. One rotation of the rotating mechanism can cause the catheter body and optical fiber to rotate about the longitudinal axis at least two times. One rotation of the rotating mechanism can cause the catheter body and optical fiber to rotate about the longitudinal axis about four times.

10 **[00039]** In general, a catheter for use with optical coherence tomography includes an elongate catheter body, an optical fiber, and a handle. The optical fiber extends from a proximal end to a distal end of the elongate catheter body and is attached to the catheter body near a distal end of the catheter body. The optical fiber provides a common path for optical radiation reflected from a reference and a target. The handle is attached to the proximal end of the  
15 elongate catheter body and is configured to allow rotation of the catheter body and the optical fiber relative to the handle about a longitudinal axis of the elongate catheter body.

**[00040]** This and other embodiments may include one or more of the following features. The optical fiber can be attached to the catheter body only near the distal end of the catheter body. A distal end of the optical fiber can be embedded in a solid transparent medium. The  
20 optical fiber can be not coaxial with the elongate catheter body.

**[00041]** The handle can include a spooling mechanism, the spooling mechanism configured to spool the optical fiber as it rotates. The handle can include a rotating mechanism. One rotation of the rotating mechanism can cause the catheter body and optical fiber to rotate about the longitudinal axis more than one time. One rotation of the rotating mechanism can  
25 cause the catheter body and optical fiber to rotate about the longitudinal axis at least two times. One rotation of the rotating mechanism can cause the catheter body and optical fiber to rotate about the longitudinal axis about four times.

**[00042]** In general, a method of conducting optical coherence tomography includes: transmitting optical radiation from a source through an optical fiber, the optical fiber extending  
30 from a proximal end to a distal end of an elongate catheter body, the optical fiber attached to the catheter body near a distal end of the catheter body; transmitting the optical radiation from the optical fiber to a first position on a target; transmitting optical radiation reflected from the target and reflected from a reference along a common path in the optical fiber to a detector; receiving the reflected optical radiation at a detector; generating a first image of the first position of the  
35 target based upon the reflected optical radiation received by the detector; and manually rotating

the catheter body and the optical fiber about a longitudinal axis of the catheter body such that a second image from a second position on the target can be obtained.

**[00043]** This and other embodiments may include one or more of the following features.

Transmitting optical radiation can include transmitting swept-source radiation. Rotating the elongate catheter body and the optical fiber can include rotating a distal end of the catheter body and a distal end of the optical fiber together. Rotating the optical fiber can include spooling the optical fiber around a spooling mechanism of a handle attached to the proximal end of the catheter body. Rotating the elongate body and the optical fiber can include rotating a rotating mechanism of a handle attached to the proximal end of the catheter body such that the elongate body and the optical fiber rotate relative to the handle. Rotating the rotating mechanism once can cause the catheter body and optical fiber to rotate about the longitudinal axis more than one time. Rotating the rotating mechanism once can cause the catheter body and the optical fiber to rotate about the longitudinal axis at least two times. Rotating the mechanism once can cause the catheter body and the optical fiber to rotate about the longitudinal axis about four times.

**[00044]** The embodiments described herein may have one or more of the following advantages.

**[00045]** Using an OCT system with a common path optical fiber and an interface medium having indexes of refraction that are mismatched allows the OCT receiving electronics to operate in a total noise range that is within 5 dB of the shot noise limit. Operating within 5 dB of the shot noise limit advantageously ensures that noise in the receiving electronics is low. Keeping noise in the receiving electronics low results in a higher quality image. When used with an atherectomy catheter, for example, higher quality images advantageously allow for better identification of target tissue.

**[00046]** Using swept source optical radiation and a common path optical fiber as part of an OCT system allows for the use of a significantly simplified optical system compared to standard time-domain OCT embodiments or swept-source embodiments using Michelson or Mach-Zehnder interferometers. This allows for the most efficient use of optical radiation, which in turn permits well optimized detection of signal and commensurately higher image quality.

**[00047]** Embedding a silicon die having a reflective coating in an interface medium provides a high reflectivity surface for reflection of light from the fiber to the tissue and back from the tissue into the fiber. The high reflectivity surface ensures that a high percentage of light from the source of optical radiation will be reflected and returned from the tissue. Having more light reflected from the target improves the interference fringe contrast, resulting in a higher quality image.

- [00048] A system for OCT that includes a common path optical fiber attached to a distal end of the catheter body and a handle attached to the proximal end of the elongate catheter body to rotate the catheter and the optical fiber allows the optical fiber to rotate with the catheter body without breaking or stretching. Allowing the optical fiber to rotate with the catheter body ensures that images can be taken at 360° angles about the catheter body. Taking images at 360° angles around the catheter body ensures that more tissue can be imaged. Moreover, including an optical fiber attached to a distal end of the catheter body and a handle attached to the proximal end of the elongate body to rotate the catheter and the optical fiber advantageously avoids having an additional bulky mechanism to rotate the fiber independently of the catheter. .
- 10 [00049] These and other advantages will be apparent from the following description and claims.

### BRIEF DESCRIPTION OF THE DRAWINGS

- [00050] FIG. 1 shows an example of a prior art OCT system.
- [00051] FIG. 2A shows an exemplary OCT system as described herein.
- 15 [00052] FIG. 2B is a schematic illustration of an OCT system as described herein.
- [00053] FIG. 3A shows an exemplary graph of noise in an OCT detector vs. power.
- [00054] FIG. 3B shows an exemplary graph of a breakdown of the types of noise contributing to the total noise in the graph of FIG. 3A.
- [00055] FIG. 3C shows a chart including data drawn from the graphs in FIGS. 3A and 3B.
- 20 [00056] FIG. 4A is a top view of an exemplary mirror at the distal tip of an OCT catheter.
- [00057] FIG. 4B is a cross-sectional side view the embodiment of FIG. 4A.
- [00058] FIG. 5 shows a medical (cardiovascular) catheter system equipped with an OCT system.
- [00059] FIGS. 6A and 6B show an exemplary embodiment of a fiber uptake system.
- 25 [00060] FIG. 7 shows an exemplary OCT image from an OCT system.
- [00061] FIG. 8 shows a system for implementing the OCT system and catheter.
- [00062] FIG. 9 shows one example of an optical circuit.
- [00063] FIG. 10 is a schematic of an OCT system as described herein.
- [00064] FIG. 11 illustrates one variation of a handle, including fiber management (spool)
- 30 elements.
- [00065] FIG. 12 illustrates one example of the distal end of a catheter as described herein.

### DETAILED DESCRIPTION OF THE INVENTION

- [00066] The Optical Coherence Tomography (OCT) catheters and systems described herein are configured to provide image guided intra-vascular procedures that may be particularly useful
- 35

for the diagnosis and/or treatment of arterial disease. The systems may include a catheter, an umbilical connection, and a console. The system uses OCT to form an image of the intravascular environment close to the catheter cutter. FIG. 2B shows a schematic of one variations of an OCT system described in greater detail herein.

5 [00067] During intraluminal procedures, such as atherectomy, problems can arise as a result of failure to properly identify target tissue. By using a catheter having a common path optical fiber for OCT, proper identification of target tissue can be improved.

[00068] Referring to FIG. 2, a common-path OCT system 100 includes a laser source 102, such as a swept frequency light source. An optical fiber 104 transfers radiation from the laser source 102 to the target 114. The optical fiber 104 is in optical contact with an interface medium 106, i.e. the light exiting the optical fiber and entering the interface medium sees only one interface. In some embodiments, as shown in FIG. 2, the end of the optical fiber is embedded in the interface medium 106.

[00069] In the common-path OCT system 100, the index of refraction of the interface medium 106 is different than the index of refraction of the core of the optical fiber 104. This creates a Fresnel reflection, in which part of the light exits the core, and part of the light is reflected back. Some of the light beam that exits the optical fiber 104 will encounter the target 114 and be reflected or scattered by the target 114. Some of this reflected or scattered light will, in turn, reenter the tip of the optical fiber 104 and travel back down the fiber 104 in the opposite direction. A Faraday isolation device 112, such as a Faraday Effect optical circulator, can be used to separate the paths of the outgoing light source signal and the target and reference signals returning from the distal end of the fiber. The reflected or scattered target light and the Fresnel-reflected reference light from the fiber face can travel back to a detector 110 located at the proximal end of the optical fiber 104.

25 [00070] Because the reflected or scattered target light in the OCT system 100 travels a longer distance than the Fresnel reflected reference light, the reflected or scattered target light can be displaced by frequency, phase and or time with respect to the reference beam. For example, if swept-source radiation is used, then the light from the target will be displaced in frequency. The difference in displacement in phase, time or frequency between the reflected or scattered target light and the reference light can be used to derive the path length difference between the end of the optical fiber tip and the light reflecting or light scattering region of the target. In the case of swept source OCT, the displacement is encoded as a beat frequency heterodyned on the carrier reference beam. Embodiments of the above concept where the light paths in the reference and signal arms are common are called common path interferometers. Common path interferometry

satisfies the requirements of a low cost disposable device, as it eliminates the separate reference arm but places no additional burden on the catheter construction.

[00071] The laser source 102 can operate at a wavelength within the biological window where both hemoglobin and water do not strongly absorb the light, i.e. between 800 nm and 1.4  $\mu\text{m}$ .

5 For example, the laser source 102 can operate at a center wavelength of between about 1300 nm and 1400 nm, such as about 1310 nm to 1340 nm. The optical fiber 104 can be a single mode optical fiber for the ranges of wavelengths provided by the laser source 102.

[00072] The core of the optical fiber 104 and the interface medium 106 can have specifically-chosen indexes of reflection such that a known magnitude of Fresnel reflection is created. For  
10 example, the indexes of reflection can be chosen such that noise in the OCT system is minimized.

[00073] Noise in OCT systems comes from at least three sources: shot noise, thermal or Johnson noise, and residual intensity noise (RIN noise). There may additionally be noise from the analog-to-digital conversion process. RIN noise comes from noise intrinsic to the light  
15 source, tends to dominate at high reference powers, and can be limited by limiting the maximum laser light intensity, working with an alternative low RIN light source (non-laser), or by using balanced detection. Thermal (Johnson) noise tends to dominate at low reference power levels, and can be avoided by working at reference power levels yielding a DC photodiode current above that of the thermal noise floor.

20 [00074] Shot noise dominates in between RIN noise and thermal (Johnson) noise. Shot noise is caused by statistical fluctuations in the number of photons or electrons that carry a particular signal. For a well designed system, shot noise is the limiting factor in dynamic range. The indexes of refraction of the fiber 104 and the interface medium 106 can thus be chosen such that the OCT system 100 operates close to the shot noise limit.

25 [00075] The shot noise limit of a particular receiver is set by the responsivity of the photodetector, the detection bandwidth desired, and the reference DC power impinging on the detector element. An exemplary graph of a noise v. power is shown in FIG. 3A with a breakdown by the type of noise shown in FIG. 3B. The graphs in FIGS. 3A and 3B assume a system having 10mW of forward power, 1550nm center wavelength, 20 nm bandwidth, 1 MHz  
30 detection bandwidth, and a 1A/W responsivity.

[00076] The shot noise limit is the area 301 at the bottom of the curve in FIG. 3A, at which the noise is the lowest or where the degradation from the shot noise limit is the least. Using the graph for a particular receiver, such as the graphs shown in FIG. 3A and FIG. 3B, the desired power at the detector,  $P_{\text{det}}$ , can be determined that would place the noise within a desired range  
35 of the shot noise limit. For example, FIG. 3C shows a table of values drawn from FIG. 3B.

Referring to FIG. 3C, a power of 0.158μW would place the receiver at the minimum degradation point, 2.36dB above the shot noise limit. Moreover, reference powers of between 63.1nW and 251nW would place the noise within 3dB of the shot noise limit. Reference powers of between about 25nW to 0.631μW would place the noise within 5dB of the shot noise limit.

5 [00077] To determine the total power, P<sub>out</sub>, that must be reflected from the interface 106 to obtain the desired P<sub>det</sub>, the losses of the detector 110 must be taken into account according to Equation 1:

$$P_{det} = P_{out}(1-L) \tag{equation 1}$$

10 where P<sub>out</sub> is the power reflected from the reference interface, and L is the sum of the optical losses from the distal end of the probe to the detector 110. Therefore, assuming that P<sub>det</sub> is equal to 0.2μW (rounding from the 0.158 μW determined to place the noise as low to the shot noise limit as possible) and that the intermediate optical system operates at 90% efficiency such that L is 10%, P<sub>out</sub> is equal to 0.2μW/(0.9) = 0.2222μW.

15 [00078] The forward power at the distal end of the optical fiber prior to entering the interface medium is given by P<sub>in</sub>. Therefore, assume that that P<sub>in</sub> is equal to 10mW.

[00079] Moreover, P<sub>out</sub> and P<sub>in</sub> can be used to determine the reflectivity of the reference interface 180, according to equation 3:

$$P_{out} = P_{in}r^2 \tag{equation 3}$$

20 where r is the Fresnel coefficient of reflectivity. Therefore, assuming that P<sub>out</sub> is 0.2222μW, and P<sub>in</sub> is 10mW, as solved for via equations 2 and 3, then r is equivalent to 0.004714.

[00080] Moreover, the Fresnel equation (shown by equation 4) governs the intensity of reflection from a normal or near normal interface:

25

$$r = \left( \frac{n_1 - n_2}{n_1 + n_2} \right) \tag{equation 4}$$

where the index of refraction of the transparent medium is given by n<sub>2</sub> and that of the core is n<sub>1</sub>.

30 [00081] The index of refraction of the core of the optical fiber, n<sub>1</sub>, is fixed by the manufacturer, and varies depending upon the fiber. The optical fiber can be, for example, a Corning SMF-28e, Corning ClearCurve, OFS BF05717 and EZBend, Fujikura SR-15e with enhanced band loss resistance, Draka BendBright XS and BendBright Elite. For Corning SMF-

28e, the group refractive index of the core at 1.3 microns is 1.4677. By comparison, a Fujikura ImageFiber has  $n_1 \approx 1.500$ .

[00082] Therefore, assuming that  $|r|$  is 0.004714 as solved for with respect to equation 3 and that  $n_1$  is 1.4677, the index of refraction of the interface medium  $n_2$  should be approximately 1.4816 or 1.4539. Thus, an interface medium of either index will produce the desired reference reflection. In some embodiments, the medium with the higher index of refraction may be preferable as it may be more readily available and/or have better mechanical properties, such as tensile strength.

[00083] The interface medium used with system 100 can be, for example, an adhesive. Depending upon the required index of refraction, the interface medium can be, for example, M21-CL which is a thermal curing adhesive. Another exemplary interface medium is the Light Weld® UV curable photonics adhesive OP-4-20658, produced by Dymax corporation, Torrington CT. This adhesive, which has a refractive index of 1.585 in the cured state, is a rigid clear UV-curable adhesive that can be applied in a liquid form, and which then cures to a rigid form within seconds of exposure to UV light. Another exemplary transparent medium is EpoTek OG127-4 or OG116, produced by Epoxy Technology, Billerica MA. This has a refractive index of 1.602 in the cured state.

[00084] If an interface medium having the exact refractive index desired cannot be found (for example because it does not have the proper tensile strength or is not biocompatible), an interface medium having a refractive index that is close can be selected and the power in,  $P_{in}$ , can be adjusted accordingly. Using the known  $r$  and the desired power at the detector,  $P_{det}$ , the required power in  $P_{in}$  can then be determined according to equation 5:

$$P_{det} = P_{in} r^2 (1-L) \quad (\text{equation 5})$$

[00085] In some implementations, the interface medium can be applied in a semi-liquid state, such as by dispenser, ink jet deposition, spraying, painting, dipping, or other process. The medium may then be cured to a solid form, such as by UV curing, thermal curing, chemical curing, drying, or other process. Other processes, such as vacuum deposition of transparent medium or direct mechanical placement of the transparent medium may also be used.

[00086] The interface medium can have a minimum thickness (i.e. depth between the end of the optical fiber and the end of the interface medium) of at least  $\frac{\lambda_{min}}{2\pi}$ , where  $\lambda_{min}$  is the wavelength of light in the optical fiber. For a wavelength of over 1250 nm, this will be approximately 200 nm or greater. The interface medium can also have a thickness that is great

enough to introduce an offset between the reference reflection and the minimum distance that the target can approach the distal exit face of the fiber.

[00087] Referring back to FIG. 2 and to FIGS. 4A and 4B, the mirror 180 must be properly designed and optimized in order to fit into the small (approximately 2 mm) diameter of the catheter head and to reflect into a blood vessel tissue located up to 1 – 3 mm away from the side of the distal catheter tip. As shown in FIGS. 4B, the mirror 180 can include a silicon die 401 having a reflective coating 403. The reflective coating 403 can be, for example, a gold coating.

The reflective coating 403 can be greater than  $\frac{\lambda_{\min}}{2\pi}$ , where  $\lambda_{\min}$  is the wavelength of light in the optical fiber. For example, the metallic coating can be greater than about 2,800Å thick.

[00088] Further, the surface of the silicon die 401 under the reflective coating 403 can be polished to less than 400 nm peak-to-peak roughness, such as better than 300 nm peak-to-peak roughness, for example about 200 nm peak-to-peak roughness. An adhesive, such as nickel, titanium, or chromium, can be used to adhere the gold coating to the silicon die. The adhesive can be between about 50 Å and 200 Å thick, such as about 100 Å thick. The mirror 180 of this configuration can be at least 95% reflective, such as 98% reflective.

[00089] The mirror 180 can be placed on a slope such that it is at an angle of between 30° and 60°, such as 45° with respect to a longitudinal axis 405 of the core of the optical fiber 104. Moreover, the mirror 180 can be configured such that the total distance that the light travels from the fiber 104 to the mirror 180 and out to the sample is between 100 and 400 μm, such as between 200 and 250 μm.

[00090] As shown in FIG. 3A and 3B, the imaging system described herein can be used with a catheter, such as an atherectomy catheter 502. An opening 2610 can be formed in the catheter 502, exposing the distal end of the fiber 104. The OCT mirror 180 can be placed in the opening near the distal tip of the catheter 104, and the interface medium can cover or embed the fiber 502, groove 2608, and opening 2610.

[00091] Figure 5 shows an overview of the main components of an OCT imaging system 500 including a fiber optic catheter 502. The catheter 502 can be sized to fit into a blood vessel, e.g. can be about 2 mm in diameter. In this configuration, the OCT optical apparatus 504 (including the light source, optical circulator, and detectors) can be located at the proximal end of the catheter 502, and can be connected to an image processor and a display 506. The distal end of the catheter 502 includes the image fiber and the mirror. The system 500 is designed to be used within the body of a patient for various medical purposes, such as atherectomy. Thus, other components, such as a vacuum 510, aspiration control 508, and a debris reservoir 512 may be useful.



[00092] The system described herein may be used to produce relatively narrow angle images of a portion of an interior lumen of a human body, such as the interior of a blood vessel. Looking at a section of a tissue through a single OCT optical fiber is limited in that the useful angle of view produced by a single OCT optical fiber is at most a few degrees. In order to  
5 produce a more medically useful panoramic view of a wide arc or swath from the interior of a blood vessel, such as 45°, 90°, 120°, or more, the catheter containing the optical fiber can be rotated.

[00093] Referring to FIGS. 6A and 6B, the catheter 502 can be attached to a fiber uptake system 600. The optical fiber 604 can extend through the catheter 502 and can be attached at the  
10 distal end of the catheter 502. The fiber 604 can otherwise be allowed to float freely through the catheter 502, e.g., can be attached only at the distal end of the catheter 502. Doing so prevents build up of optical losses due to microbending or stress-induced birefringence. Further, the fiber 604 can be located off the central longitudinal axis of the catheter 502.

[00094] The fiber management system 600 incorporates the fiber on a single internal take-  
15 up spool 606. The take-up spool is configured with grooves 608 (see FIG. 6A) sized to fit the optical fiber 604. The optical fiber 608 can move up and down in the grooves 608 (i.e. radially with respect to the catheter 502) to compensate for any bending or stretching of the catheter 502.

[00095] The uptake system 600 further includes a physical limiter 610 configured to prohibit the take-up spool from rotating further than the OCT fiber 602 is configured to stretch.  
20 Moreover, a torque control knob 614 can be attached to the proximal end of the catheter 502. The knob 614 can be used to actuate rotation of the catheter, and thus rotation of the fiber 604. For example, the knob 614 can be manually activated. The knob 614 can also be motor-driven by a proximal controller 618 to provide a more controlled sector sweep of the imaging element. The knob 614 can be configured such that one rotation of the knob 614 causes the catheter 502  
25 and optical fiber 604 to rotate more than once. For example, the optical fiber 604 can rotate about the longitudinal axis at least two times, such as about four times for every single rotation of the catheter 502.

[00096] An encoder 612 in the uptake system 600 detects angle and constantly relays information regarding rotation of the fiber 604 back to the computer controlling the OCT data  
30 acquisition system. This value of the angle is incorporated into the display algorithm so as to show a 360 degree view of the inside of the lumen.

[00097] Rather than having an encoder 612, the controller 618 can include a “mouse chip” position sensor similar to those used in a computer optical mouse in order to look at the catheter and encode angular and longitudinal motion. The mouse chip can be configured to look at the  
35 surface of the catheter (or the braid if the outside laminate is transparent or translucent) and

calculate the X and Y motion vectors on the basis of the difference in feature position between adjacent snap-shots.

**[00098]** Rotating the proximal end of the catheter by 360° does not necessarily lead to a 360° rotation at the distal tip, particularly if the catheter is experiencing distributed friction over its length, for example from the introducer sheath, guides, tissue friction especially in a tight lesion. By using a mouse chip, rotation and longitudinal motion of the catheter can be detected while eliminating the unsupported length effect.

**[00099]** An exemplary image or display of a catheter 502 in a lumen 702 is shown in FIG. 7. The display can be continually refreshed by rotating the catheter in either direction. The whole display can also be rotated and oriented with respect to the fluoroscopic view being acquired simultaneously in the cath lab using X-ray. For example, the image may be rotated so that the pericardium is “Up” or “Down”. By orienting the display and knowing the spatial relationship between the catheter and the display (and by implication the critical physiological structures in the vessel), the physician may orient the device as required, e.g. to cut an occlusion properly.

**[000100]** The OCT system 100 described herein can produce images, e.g. images of tissue morphology, having a resolution of around 6-15 microns, e.g. 8-10 microns, and to depths of 1-2mm depending on the optical properties of the sample being imaged. The axial resolution of the OCT system can be about ten times higher than that of a similar ultrasound system.

**[000101]** FIG. 8 shows a system 2700 for implementing the OCT system and catheter described herein. A power supply 2713 supplies power to the OCT engine 2703, the computer processor 2707, and the optical system 2711. A trigger 2701 in the OCT engine 2703 is connected to a trigger 2705 in the computer processor 2707 to begin processing of the image. Moreover, the catheter handle encoder 2715 is attached to the computer processor 2707 to transfer signals related to the location and rotation of the optic fiber. The OCT detector 2717 is attached to the computer processor 2707 to process the final image. Finally, a video signal is sent from the computer processor 2707 to a monitor 2709 to output the image to the user.

**[000102]** In some embodiments, the OCT system and catheter described herein can image up to 1-2 mm in depth with resolutions around 8-10 microns, sufficient to give the physician highly detailed images almost to the cellular organization level and visibility beyond the maximum cut range of the catheter. Moreover, the OCT atherectomy catheter described in can advantageously have imaging capability with crossing-profile impact that is much smaller than traditional OCT systems and ultrasound transducers.

EXAMPLE

- 5 [000103] In one example, an image-guided interventional catheter (e.g., an OCT catheter as described above) may be used to address unmet needs in peripheral and coronary artery disease (atherosclerosis). The system may include a console having a modest footprint and in a cath lab without need for extensive integration into cath lab systems. In some variations, the systems described herein may be integrated with other catheter (e.g., guidance, control, imaging) systems. The system may be configured to allow a procedure to start / proceed / finish under fluoro guidance in the event of a system failure. The system is also configured to be compatible with sterile procedures.
- 10 [000104] As mentioned above, the OCT systems described herein may allow real-time information on intravascular lesion morphology and device orientation in the vessel. This and other features may also allow improved navigation precision around complex anatomy (e.g., bifurcations, ostials, tortuosity, cutting on a curve, etc.), and around stent struts. The catheters may be safely used to traverse diseased tissue while reducing incidence of perforations and dissections potentially associated with a more aggressive treatment strategy. The systems may also provide immediate assessment of acute procedural success, and a reduction in procedure time compared to contemporary interventional techniques. The systems described herein may allow imaging of vessel wall morphology in real time and at a level of precision that could assist the physician in making a “diseased / not-diseased” determination.
- 15 [000105] In one example, the OCT system is configured to allow tissue morphology to be imaged in real time with resolution routinely around 8 – 10 microns, and to depths of 1 – 2 mm depending on the optical properties of the tissue. The axial resolution of OCT is sufficiently high that the images presented to the operator substantially resemble histology from optical microscopy, and are as a result more intuitively interpreted than ultrasound or MRI / CT images. The depth to which OCT can image through tissue with minimal to moderate lipid content is sufficient to give the physician visibility beyond the maximum proposed depth of cut for an atherectomy catheter, allowing the safety margins of the putative cut to be assessed.
- 20 [000106] As mentioned, OCT has several other technical and economic advantages for catheter applications. The impact on catheter crossing profile of the OCT optical fiber is much smaller than for even the smallest comparable ultrasound transducer. The axial resolution of OCT is typically 10x higher than ultrasound; this translates directly to image interpretability. The limited depth of penetration of typical OCT devices is not of primary concern in this application in many applications, because it is known from prior atherectomy procedures that substantial clinical benefit can be obtained by removing several hundred micron thicknesses of tissue. The depth of penetration may be matched to the expected maximum cut depth. Regions of particularly deep
- 25  
30  
35

or thick tissue (target tissue to be removed) may be identified and treated serially or separately. For example, highly lipid-rich tissues (necrotic cores) appear as dark voids in OCT images, typically with bright caps.

5 [000107] The center wavelength for the optical system may be chosen to provide sufficient depth of penetration, as well as compatibility with the components of the system. For example, the OCT systems may use light that can be transmitted through fused silica fiber optics (where the primary investment in cost and quality has been made). The wavelength range to 250 – 2000 nm may be particularly useful. Single mode fibers can be readily obtained at any of these wavelength ranges, although wavelengths above 400 nm may be preferable. Other wavelengths  
10 could be used, but there may be significant toxicity issues with fiber materials transmitting further into the infrared, and optical sources with the appropriate properties may be difficult to obtain. Below 250 nm air-guiding fibers may be used, however these may be less desirable. In this example, we assume a range of between about 250 – 2000 nm.

15 [000108] It may be easier to “see” through small annuli of either blood, saline or mixtures by restricting the scan range of the source to regions where hemoglobin and water do not strongly absorb light. This leads to the use of a “biological window” between about 800 nm and 1.4 microns.

[000109] The dominant mechanism restricting penetration depth in biological tissue when using ballistic optical scattering techniques is the photon scattering cross-section in the tissue.  
20 Higher scattering cross-sections causes fewer photons to traverse from source to target and back ballistically, that is with only one scattering event at the target leading to a reduction in useful signal. The scattering cross-section scales as an inverse power of wavelength over the 250 – 2000 nm range, transitioning from an exponent of -4 at shorter wavelengths to a smaller value at longer wavelengths. The value decreases monotonically going from short to longer wavelengths  
25 so, if our need is to see deeper in tissue, the wavelength range of the source should be biased to longer wavelengths. However, this choice is not without compromise. Moving to longer wavelengths may require a more sophisticated laser source to achieve the same resolution compared to imaging at shorter wavelengths, however this is a soluble technical problem.

[000110] In some variations the system takes advantage of the widespread availability of  
30 cheap, high quality parts. For example, fiber-based telecommunications has evolved at three specific center wavelength ranges; 800 (LAN only), 1310 (O-band) and 1550 nm (C-band). The systems described herein may restrict the choice of center wavelength to 1310 nm, however this does not mean that the other two wavelength ranges could not be made to work. For example, the 800 nm center wavelength range is routinely used in ophthalmology, where depth of

penetration can be sacrificed for tissue layer resolution and where fiber delivery is not a requirement (free-space optics may be used).

[000111] In some variations, the system works in the telecommunications O-band. In practice the range of center wavelength is 1315 – 1340 nm may be dictated by the availability of suitable laser sources in the O-band.

[000112] There are three primary categories of source / detector combinations in OCT, namely Time-Domain, Spectral-Domain (Fourier Domain or Spectral Radar) and Swept Source OCT. The examples of OCT systems described herein are swept source OCT (SS-OCT), which allow for video-rate imaging, few or no moving parts, a simple optical system suitable for fiber implementation, imaging to depths greater than 1 mm, and insensitivity to the rigors of a mobile environment.

[000113] As discussed above, several interferometer configurations may be used. The systems described herein are Common Path Interferometry (CPI) systems. This has several advantages given the goal of catheter based imaging with cost-constrained capital equipment and disposable devices. The SS-OCT with CPI system described herein preserves the Fellgett Advantage. Fellgett's advantage or the multiplex advantage is an improvement in spectroscopic techniques that is gained when an interferometer is used instead of a monochromator or scanning delay line. The improvement arises because when an interferometer is employed, the radiation that would otherwise be partially or wholly rejected by the monochromator or scanning delay line in its path retains its original intensity. This results in greater efficiency. This embodiment contrasts this with the other systems, in which only a small fraction of the laser power is useful at any given time. For example, the Lightlab™ M2 system uses TD-OCT with a scanning delay line, which is equivalent for the purposes of the Fellgett Advantage to a monochromator. Clinically, the Fellgett advantage impacts imaging speed (frame update rate), allowing significant improvements in video display rates which translate to a reduction in ambiguity in interpreting the image.

[000114] The CPI systems described herein also preserve the Jacquinot Advantage. The Jacquinot advantage states that in a lossless optical system, the brightness of the object equals the brightness of the image. Assuming that losses due the optical components are negligible, an interferometer's output will be nearly equal in intensity to the input intensity, thus making it easier to detect the signal. This translates directly to image quality, and a more interpretable image.

[000115] The CPI system as described herein therefore makes highly efficient use of the laser power. Light is either used for the reference reflection or impinges on the tissue and is used to create signal. No light is lost in attenuators or additional optical components or unused reciprocal

paths. This efficient use of laser power is most apparent in the ability of the system to display clinically relevant images of the intravascular environment in real time, without the need for extensive post processing or even on-the-fly image correction.

5 **[000116]** Furthermore, these systems are “down-lead insensitive”, allowing the connection from catheter to console to be of almost arbitrary length without forcing a matched reference delay line to be shipped with each catheter. This minimizes the additional cost impact of the imaging components added to the catheter. It also allows a console component to be positioned almost anywhere, minimizing the potential disruption to work flow and minimizing the threat to a sterile field.

10 **[000117]** The systems described herein also minimize the number of optical components in the imaging system which could contribute to chromatic aberration. This minimization preserves the spectral fidelity of the laser source optimizing the layer resolution. This translates directly to image quality, and a more interpretable image.

15 **[000118]** The common-path systems described herein also have exceptional phase stability. Path length changes affecting the sample arm (temperature changes, stress-induced birefringence etc) also affect the reference arm identically. The distance from the ZPD (zero-pathlength difference) point (the reference plane) to the sample is physically fixed and is not subject to variability due to turbulence. This exceptional phase stability coupled with the exceptional phase stability of the OCT engine means that the Z-axis of the display (depth) has minimal jitter, in  
20 turn maximizing the real-time interpretability of the image. It also allows us to perform mathematical manipulation of the data that would otherwise be impossible. For example, one advantage of the systems described herein is the ability to perform pre-FFT averaging, which lowers the overall noise floor of the system again translating directly to image quality and interpretability.

25 **[000119]** In one example, the catheter is around 2 mm in diameter (7F compatible). In a saline-filled lumen, the system will be able to detect an interface (e.g., vessel wall) at 2 mm from the OD of the catheter. In this variation, the following parameters may be used for the catheter and system:

Specifications	Value
Optimized Detector Bandwidth	DC – 10 MHz
Nyquist / Shannon rate	20 MHz
Minimum number of points to sample for full resolution	630

[000120] The detector may detect optical modulation on the carrier wave from DC to at least 10 MHz with no roll-off in sensitivity. To prevent aliasing (which complicates image interpretation) we may digitize the detector output at a minimum of 20 M-Samples/sec (Nyquist limit) to preserve interpretable real time imaging capability. We may thus capture at least 630 points per laser pulse at this digitizer rate to avoid undersampling the available laser bandwidth.

[000121] A practical resolution target is the intima of healthy coronary artery. The system resolution is capable of showing the intima (endothelial layer + internal elastic lamina) as a single sharp bright line on the display.

[000122] The system may have an impulse response of 8 – 10 microns. This resolution dictates the laser scan range requirements and the bandwidth requirements of all the optical components in the fiber harness through the equation:

$$\delta z = \frac{2 \ln 2}{\pi} \frac{\lambda_0^2}{n \Delta \lambda}$$

Where  $\delta z$  is the axial resolution,  $\lambda$  is the wavelength,  $\Delta \lambda$  is the wavelength range over which the laser scans,  $n$  is the refractive index of the medium and the other symbols have their usual meaning. The origin of this relationship is the Heisenberg Uncertainty Principle. Several observations accrue from this equation.

[000123] If the laser scan range  $\Delta \lambda$  is not broad enough,  $\delta z$  (the resolution) is compromised and an image of a step refractive index discontinuity will be blurred out over many pixels. If any of the optical components in the system restrict (alternatively called clipping or vignetting) the effective bandwidth of the system is reduced and the resolution may suffer. Since the resolution equation has the center wavelength squared in the numerator, as we move to longer center wavelengths for the reasons described above, commensurately larger laser scan range may achieve equivalent axial resolution. Ophthalmology is routinely performed at 800 or 1000 nm center wavelength where there is no need to image deeply into the retina but where the available lasers allow extremely high resolution of the layers of the retina (down to 1 – 2 microns thickness).

[000124] In some variations, the OCT system has a scan range of > 100 nm. The theoretical resolution of this engine is 6.35 microns in a medium with a refractive index of 1.35. Stipulating that we digitize at least at the Nyquist limit, fully sample the scanned bandwidth, and that the rescaling procedure in the software does not distort the data, the theoretical resolution of this system is sufficient to show the intima of a healthy coronary at the impulse response limit.

[000125] The choice of 1310 nm as a center wavelength for the laser means that we may use standard commercial off-the-shelf telecommunications components which have guaranteed performance at this wavelength and for which standardized test protocols exist. Reasonable and

customary incoming inspection procedures can be used to verify that the components going into the system will not deteriorate image quality.

[000126] As mentioned above, the system may include receiving electronics including a detector. Assuming that the operating center wavelength is 1315 – 1340 nm with a full-width  
5 half maximum responsivity of >100 nm, and that the detector operates as close as reasonably possible to the shot-noise limited regime, the system may have sufficient trans-impedance gain from the detector to allow the A/D card to operate at an input range where digitizer noise is not a dominant contributor to the noise floor of the system.

[000127] Manufacturing tolerances on the catheters will yield a range of distal tip reference  
10 reflection intensities. The detector may be configured or chosen so as not to saturate at the high manufacturing limit of the reference reflection power. In one example, the system uses a Fermionics FD80 photodiode in an FC receptacle package as the active element in the photodetector.

[000128] The system may also include a fiber harness designed to: 1) provide a low loss  
15 pathway from the laser to the catheter, 2) route signal light returning from the catheter to the detector, 3) allow the bleed-in of a red laser diode signal to allow rapid assessment of the integrity of the fiber from cable to distal tip, and 4) provide manufacturing, calibration and field service housekeeping signals to facilitate console production, validation and maintenance.

[000129] One primary component of the fiber harness may be a self-contained enclosure with  
20 bulkhead FC/APC receptacles on it and containing an optical circuit (such as the one shown in FIG. 9).

[000130] In one example, the fiber harness may be connected as: #1 Incoming OCT source  
(e.g., Santec) Santec output connected here. #2 Diagnostic port (OSA / Photodiode / MZI Calibration); #3 Diagnostic port (OSA / Photodiode / MZI Calibration); #4 Connection to  
25 Detector; #5 Reflected FBG Marker (Time / Wavelength Calibration Point); #6 Connection to Catheter; #7 Transmitted FBG Signal (Photodiode scope trigger); #8 Connection to red laser source. Connections may be made with single mode fiber with a cut-off of <1260 nm. The inputs / outputs do not need to be optically isolated.

[000131] In some variations, an electrical harness may be used. The electrical harness may be  
30 configured to: 1) provide isolation for the various electrical components in the imaging system; 2) distribute 110V to the OCT engine, slave monitor and computer; 3) provide regulated isolated housekeeping power at appropriate voltages and amperages to the detector, red diode laser, catheter handle azimuthal position encoder; 4) send the video signal to the remote monitor; and 5) receive the catheter handle azimuthal angle encoder signal back to the console.



[000132] Line power may enter the console through a standard IEC60320 type C14 male power cord entry connector. The power cord used may be Hospital Grade and may have a standard IEC60320 type C13 female connector at the console end. An isolation transformer can distribute LINE power to the OCT engine, slave monitor and computer through IEC standard power cords.

5 [000133] FIG. 10 shows one example of a schematic of an OCT system as described herein. In this example, Items with dotted perimeters are outside the main console chassis enclosure. Analog signal interconnects are to be made with RG58 (U, A/U) patch cables terminated with BNC connectors. The (Santec) Trigger Out signal is a falling edge signal (high Z) and should not be terminated in 50 ohms. The Encoder Signal should be terminated with a MiniCircuits low  
10 pass filter module at the A/D card to remove high frequency spurious noise. The Detector Signal should be terminated with a MiniCircuits low pass filter module at the A/D card to remove any noise in an irrelevant frequency range.

[000134] FIG. 11 illustrates one variation of a handle, shown schematically. FIG. 12 illustrates one example of the distal end of a catheter as described herein. In this example, the distal end of  
15 the catheter includes a fiber having a core that is embedded in a transparent medium as described above. The fiber has an OD of 0.0065" and is polyimide coated and flat-cleaved (at 90°). The polyimide is stripped from the end to about 500 microns. The mis-match between the refractive indexes of the core and the embedding medium gives a 32-35 dB return loss after curing.

[000135] The optical fiber may have a cut-off less than 1260 nm and have single mode  
20 performance between 1270 and 1380 nm (and be manufactured compatible with SMF-28 standards). Dissimilar fibers are not preferred as they may populate higher-order spatial modes or generate spurious return loss > 65 dB at any given event. The mechanical connections (pigtail and patch cable) may include a simplex cable, and an inner loose tube Teflon Aramid fiber inner annulus to prevent stretching. The outer Jacket may be 2 mm polyurethane. The connector may  
25 be a Diamond E2108.6 connector with a 0.25 dB maximum insertion loss and a -65 dB maximum return loss.

[000136] The distal tip reference reflection (mirror) may include at least one (1) reflective interface, and may have a return loss of -33.5 dB (Nominal (31 – 35 dB)). There may be 200 –  
250 microns solid transparent offset from interface to minimum tissue approach point.  
30 Interceding optical discontinuities between console and catheter distal tip may be kept to less than 65 dB return loss maximum for any individual surface. The number of reflective interfaces separated by less than 8 mm may be minimized. The parameters above are exemplary only, and may be varied as understood by those of skill in the art, while still remaining in the spirit of the invention as described herein.

[000137] The examples and illustrations included herein show, by way of illustration and not of limitation, specific embodiments in which the subject matter may be practiced. Other embodiments may be utilized and derived there from, such that structural and logical substitutions and changes may be made without departing from the scope of this disclosure.

5 Such embodiments of the inventive subject matter may be referred to herein individually or collectively by the term “invention” merely for convenience and without intending to voluntarily limit the scope of this application to any single invention or inventive concept, if more than one is in fact disclosed. Thus, although specific embodiments have been illustrated and described herein, any arrangement calculated to achieve the same purpose may be substituted for the

10 specific embodiments shown. This disclosure is intended to cover any and all adaptations or variations of various embodiments. Combinations of the above embodiments, and other embodiments not specifically described herein, will be apparent to those of skill in the art upon reviewing the above description.

## CLAIMS

1. A system for optical coherence tomography, comprising:  
a source of optical radiation;  
an optical fiber having a core providing a common path for optical radiation reflected  
5 from a reference interface and a target, the core having a first refractive index;  
receiving electronics configured to receive the optical radiation reflected from the  
reference interface and the target;  
an interface medium at the reference interface and in optical contact with the optical  
fiber, the interface medium having a second refractive index, wherein the first refractive index  
10 and the second refractive index are mismatched such that the receiving electronics operate in a  
total noise range that is within 5 dB of the shot noise limit; and  
a processor to generate an image of the target based upon the optical radiation received  
by the receiving electronics.
- 15 2. The system of claim 1, wherein the first refractive index and the second refractive index  
are mismatched such that the receiving electronics operate in a total noise range that is within 3  
dB of the shot noise limit.
3. The system of claim 1, wherein the first refractive index and the second refractive index  
20 are mismatched such that the receiving electronics operate in a total noise range that is within 2  
dB of the shot noise limit.
4. The system of claim 1, wherein the source of optical radiation is a swept-frequency  
source.
- 25 5. The system of claim 1, further comprising a mirror in the interface medium, the mirror  
configured to reflect the optical radiation from the optical fiber to the target.
6. The system of claim 5, wherein the mirror comprises a gold-coated silicon die.
- 30 7. The system of claim 1, wherein the interface medium is a solid transparent medium.
8. The system of claim 1, wherein the interface medium is in optical contact with a distal  
end of the core.

35

9. The system of claim 1, further comprising a directional element configured to relay the optical radiation from the source to a distal end of the core.

10. The system of claim 1, wherein the first refractive index  $n_1$  and the second refractive index  $n_2$  are mismatched such that:

$$\frac{P_{out}}{P_{in}} = \left( \frac{n_1 - n_2}{n_1 + n_2} \right)$$

wherein  $P_{in}$  is the power of the optical radiation at the distal end of the optical fiber prior to entering the interface medium, and wherein  $P_{out}$  is the power of the optical radiation reflected from the reference interface such that the receiving electronics operate in a total noise range that is within 5 dB of the shot noise limit.

11. The system of claim 10, wherein the first refractive index  $n_1$  and the second refractive index  $n_2$  are mismatched such that:

$$P_{dst} = P_{out}(1 - L)$$

wherein  $L$  is the sum of all the optical losses from the distal end of the probe to the receiving electronics and  $P_{dst}$  is the power at the receiving electronics.

12. A catheter for use with optical coherence tomography, comprising:  
an elongate catheter body;

an optical fiber in the elongate catheter body, the optical fiber having a core providing a common path for optical radiation reflected from a reference interface and a target, the core having a first refractive index; and

an interface medium at the reference interface and in optical contact with the optical fiber, the interface medium having a second refractive index, wherein the first refractive index and the second refractive index are mismatched such that receiving electronics configured to receive optical radiation reflected from the reference interface and the target operate in a total noise range that is within 5 dB of the shot noise limit.

13. The catheter of claim 12, wherein the first refractive index and the second refractive index are mismatched such that the receiving electronics operate in a total noise range that is within 3 dB of the shot noise limit.

14. The catheter of claim 12, wherein the first refractive index and the second refractive index are mismatched such that the receiving electronics operate in a total noise range that is within 2 dB of the shot noise limit.

5

15. The catheter of claim 12, further comprising a mirror in the interface medium, the mirror configured to reflect the optical radiation from the optical fiber to the target.

16. The catheter of claim 15, wherein the mirror comprises a gold-coated silicon die.

10

17. The catheter of claim 12, wherein the interface medium is a solid transparent medium.

18. The catheter of claim 12, wherein the interface medium is in optical contact with a distal end of the core.

15

19. The catheter of claim 12, wherein the first refractive index  $n_1$  and the second refractive index  $n_2$  are mismatched such that:

$$\frac{P_{out}}{P_{in}} = \left( \frac{n_1 - n_2}{n_1 + n_2} \right)$$

wherein  $P_{in}$  is the power of the optical radiation at the distal end of the optical fiber prior to entering the interface medium, and wherein  $P_{out}$  is the power of the optical radiation reflected from the reference interface such that the receiving electronics operate in a total noise range that is within 5 dB of the shot noise limit.

20

20. The catheter of claim 19, wherein the first refractive index  $n_1$  and the second refractive index  $n_2$  are mismatched such that:

25

$$P_{dst} = P_{out}(1 - L)$$

wherein  $L$  is the sum of all the optical losses from the distal end of the probe to the receiving electronics and  $P_{dst}$  is the power at the receiving electronics.

30

21. A method of performing optical coherence tomography, comprising:

transmitting optical radiation from a source through an optical fiber having a core, the core having a first refractive index;

transmitting the optical radiation from the optical fiber through an interface medium, wherein the interface medium is in optical contact with the optical fiber, the interface medium  
5 having a second refractive index;

transmitting optical radiation reflected from the target and reflected from a reference interface along a common path in the optical fiber to a detector;

receiving the reflected optical radiation at receiving electronics, wherein the first refractive index and the second refractive index are mismatched such that the receiving  
10 electronics operate in a total noise range that is within 5 dB of the shot noise limit; and

generating an image of the target based upon the reflected optical radiation received by the receiving electronics.

22. The method of claim 21, wherein the first refractive index and the second refractive index  
15 are mismatched such that the receiving electronics operate in a total noise range that is within 3 dB of the shot noise limit.

23. The method of claim 21, wherein the first refractive index and the second refractive index  
20 are mismatched such that the receiving electronics operate in a total noise range that is within 2 dB of the shot noise limit.

24. The method of claim 21, wherein transmitting optical radiation comprises transmitting swept-source radiation.

25. The method of claim 21, wherein transmitting the optical radiation from the optical fiber  
25 through the interface medium further comprises transmitting the optical radiation from the optical fiber to a mirror in the interface medium.

26. A system for optical coherence tomography, comprising:

30 a source of optical radiation;

an optical fiber providing a common path for optical radiation reflected from a reference and a target;

a detector to receive the optical radiation reflected from the reference and the target;

35 an interface medium at the reference interface and in optical contact with the distal end of the optical fiber;

a mirror in the embedding medium, the mirror comprising a silicon die having a reflective coating; and

a processor to generate an image of the target based upon the optical radiation received by the detector.

5

27. The system of claim 26, wherein the reflective coating is metallic.

28. The system of claim 27, wherein the metallic coating is gold.

10 29. The system of claim 26, wherein the reflective coating has a thickness of at least  $\frac{\lambda_{\min}}{2\pi}$ , where  $\lambda_{\min}$  is the wavelength of light in the optical fiber.

30. The system of claim 29, wherein the metallic coating is at least 2,800 Å thick.

15 31. The system of claim 26, further comprising an adhesion layer between the silicon die and the reflective coating.

32. The system of claim 31, wherein the adhesion layer comprises nickel, titanium, or chromium.

20

33. The system of claim 30, wherein the adhesion layer is between 50 Å and 200 Å thick.

34. The system of claim 33, wherein the adhesion layer is about 100 Å thick.

25 35. The system of claim 26, wherein the interface medium comprises an adhesive.

36. The system of claim 26, wherein the mirror is at least 95% reflective.

37. The system of claim 36, wherein the mirror is at least 98% reflective.

30

38. The system of claim 26, wherein the interface medium is a solid transparent medium.

39. The system of claim 26, wherein the source of optical radiation is configured to provide swept-source radiation.

40. A catheter for use with optical coherence tomography, comprising:  
an elongate catheter body;  
an optical fiber in the elongate catheter body, the optical fiber providing a common path  
5 for optical radiation reflected from a reference interface and a target;  
an interface medium at the reference interface and in optical contact with a distal end of  
the optical fiber; and  
a mirror in the interface medium, the mirror comprising a silicon die having a reflective  
coating.
- 10
41. The catheter of claim 40, wherein the interface medium comprises an adhesive.
42. The catheter of claim 40, wherein the reflective coating is metallic.
- 15 43. The catheter of claim 42, wherein the metallic coating is gold.
44. The system of claim 40, wherein the reflective coating has a thickness of at least  $\frac{\lambda_{\min}}{2\pi}$ ,  
where  $\lambda_{\min}$  is the wavelength of light in the optical fiber.
- 20 45. The system of claim 44, wherein the metallic coating is at least 2,800 Å thick.
46. The catheter of claim 40, further comprising an adhesion layer between the silicon die  
and the reflective coating.
- 25 47. The catheter of claim 46, wherein the adhesion layer comprises nickel, titanium, or  
chromium.
48. The catheter of claim 46, wherein the adhesion layer is between 50 Å and 200 Å thick.
- 30 49. The catheter of claim 48, wherein the adhesion layer is about 100 Å thick.
50. The catheter of claim 41, wherein the mirror is at least 95% reflective.
51. The catheter of claim 50, wherein the mirror is at least 98% reflective.



52. A method of performing optical coherence tomography, comprising:  
transmitting optical radiation from a source through an optical fiber;  
transmitting the optical radiation from the optical fiber to a mirror embedded in an  
5 interface medium, wherein the mirror comprises a silicon die having a reflective coating, and  
wherein the interface medium is in optical contact with a distal end of a core of the optical fiber;  
reflecting the optical radiation from the mirror to a target;  
reflecting the optical radiation from a reference interface, the reference interface between  
the optical fiber and the interface medium;  
10 transmitting optical radiation reflected from the target and reflected from the reference  
interface along a common path in the optical fiber to a detector;  
receiving the reflected optical radiation at a detector; and  
generating an image of the target based upon the reflected optical radiation received by  
the detector.  
15
53. The method of claim 52, wherein transmitting optical radiation comprises transmitting  
swept-source radiation.
54. The method of claim 52, wherein the reflective coating is metallic.  
20
55. The method of claim 54, wherein the metallic coating is gold.
56. The system of claim 52, wherein the reflective coating has a thickness of at least  $\frac{\lambda_{\min}}{2\pi}$ ,  
where  $\lambda_{\min}$  is the wavelength of light in the optical fiber.  
25
57. The system of claim 56, wherein the metallic coating is at least 2,800 Å thick.
58. The method of claim 52, further comprising an adhesion layer between the silicon die and  
the reflective coating.  
30
59. The method of claim 58, wherein the adhesion layer comprises nickel, titanium, or  
chromium.
60. The method of claim 58, wherein the adhesion layer is between 50 Å and 200 Å thick.

61. The method of claim 59, wherein the adhesion layer is about 100 Å thick.
62. The method of claim 52, wherein the mirror is at least 95% reflective.
- 5 63. The method of claim 62, wherein the mirror is at least 98% reflective.
64. A system for optical coherence tomography, comprising:  
a source of optical radiation;  
10 an elongate catheter body;  
an optical fiber extending from a proximal end to a distal end of the elongate catheter  
body, the optical fiber fixed to a distal end of the catheter body, wherein the optical fiber  
provides a common path for optical radiation reflected from a reference and a target;  
a handle attached to the proximal end of the elongate catheter body, the handle  
15 configured to allow rotation of the catheter body and the optical fiber relative to the handle  
about a longitudinal axis of the elongate catheter body;  
a detector to receive the optical radiation reflected from the reference and the target; and  
a processor to generate an image of the target based upon the optical radiation received  
by the detector.
- 20 65. The system of claim 64, wherein the optical fiber is fixed to the catheter body only near  
the distal end of the catheter body.
66. The system of claim 64, wherein a distal end of the optical fiber is embedded in a solid  
25 transparent medium.
67. The system of claim 64, wherein the optical fiber is not coaxial with the elongate catheter  
body.
- 30 68. The system of claim 64, wherein the handle comprises a spooling mechanism, the  
spooling mechanism configured to spool the optical fiber as it rotates.
69. The system of claim 64, wherein the handle comprises a rotating mechanism, wherein  
one rotation of the rotating mechanism causes the catheter body and optical fiber to rotate about  
35 the longitudinal axis more than one time.

70. The system of claim 69, wherein one rotation of the rotating mechanism causes the catheter body and optical fiber to rotate about the longitudinal axis at least two times.
- 5 71. The system of claim 70, wherein one rotation of the rotating mechanism causes the catheter body and optical fiber to rotate about the longitudinal axis about four times.
72. A catheter for use with optical coherence tomography, comprising:  
an elongate catheter body;  
10 an optical fiber extending from a proximal end to a distal end of the elongate catheter body, the optical fiber fixed to the catheter body near a distal end of the catheter body, wherein the optical fiber provides a common path for optical radiation reflected from a reference and a target; and  
a handle attached to the proximal end of the elongate catheter body, the handle  
15 configured to allow rotation of the catheter body and the optical fiber relative to the handle about a longitudinal axis of the elongate catheter body.
73. The catheter of claim 72, wherein the optical fiber is fixed to the catheter body only near the distal end of the catheter body.
- 20 74. The catheter of claim 72, wherein a distal end of the optical fiber is embedded in a solid transparent medium.
75. The catheter of claim 72, wherein the optical fiber is not coaxial with the elongate  
25 catheter body.
76. The catheter of claim 72, wherein the handle comprises a spooling mechanism, the spooling mechanism configured to spool the optical fiber as it rotates.
- 30 77. The catheter of claim 72, wherein the handle comprises a rotating mechanism, wherein one rotation of the rotating mechanism causes the catheter body and optical fiber to rotate about the longitudinal axis more than one time.
78. The catheter of claim 77, wherein one rotation of the rotating mechanism causes the  
35 catheter body and optical fiber to rotate about the longitudinal axis at least two times.

79. The catheter of claim 78, wherein one rotation of the rotating mechanism causes the catheter body and optical fiber to rotate about the longitudinal axis about four times.

- 5 80. A method of conducting optical coherence tomography, comprising:  
transmitting optical radiation from a source through an optical fiber, the optical fiber  
extending from a proximal end to a distal end of an elongate catheter body, the optical fiber fixed  
to the catheter body near a distal end of the catheter body;  
transmitting the optical radiation from the optical fiber to a first position on a target;  
10 transmitting optical radiation reflected from the target and reflected from a reference  
along a common path in the optical fiber to a detector;  
receiving the reflected optical radiation at a detector;  
generating a first image of the first position of the target based upon the reflected optical  
radiation received by the detector; and  
15 manually rotating the catheter body and the optical fiber about a longitudinal axis of the  
catheter body such that a second image from a second position on the target can be obtained.

81. The method of claim 17, wherein transmitting optical radiation comprises transmitting  
swept-source radiation.

- 20 82. The method of claim 17, wherein rotating the elongate catheter body and the optical fiber  
comprises rotating a distal end of the catheter body and a distal end of the optical fiber together.

83. The method of claim 17, wherein rotating the optical fiber comprises spooling the optical  
25 fiber around a spooling mechanism of a handle attached to the proximal end of the catheter body.

84. The method of claim 17, wherein rotating the elongate body and the optical fiber  
comprises rotating a rotating mechanism of a handle attached to the proximal end of the catheter  
body such that the elongate body and the optical fiber rotate relative to the handle.

30 85. The method of claim 84, wherein rotating the rotating mechanism once causes the  
catheter body and optical fiber to rotate about the longitudinal axis more than one time.

86. The method of claim 85, wherein rotating the rotating mechanism once causes the  
35 catheter body and the optical fiber to rotate about the longitudinal axis at least two times.

87. The method of claim 86, wherein rotating the rotating mechanism once causes the catheter body and the optical fiber to rotate about the longitudinal axis about four times.

5

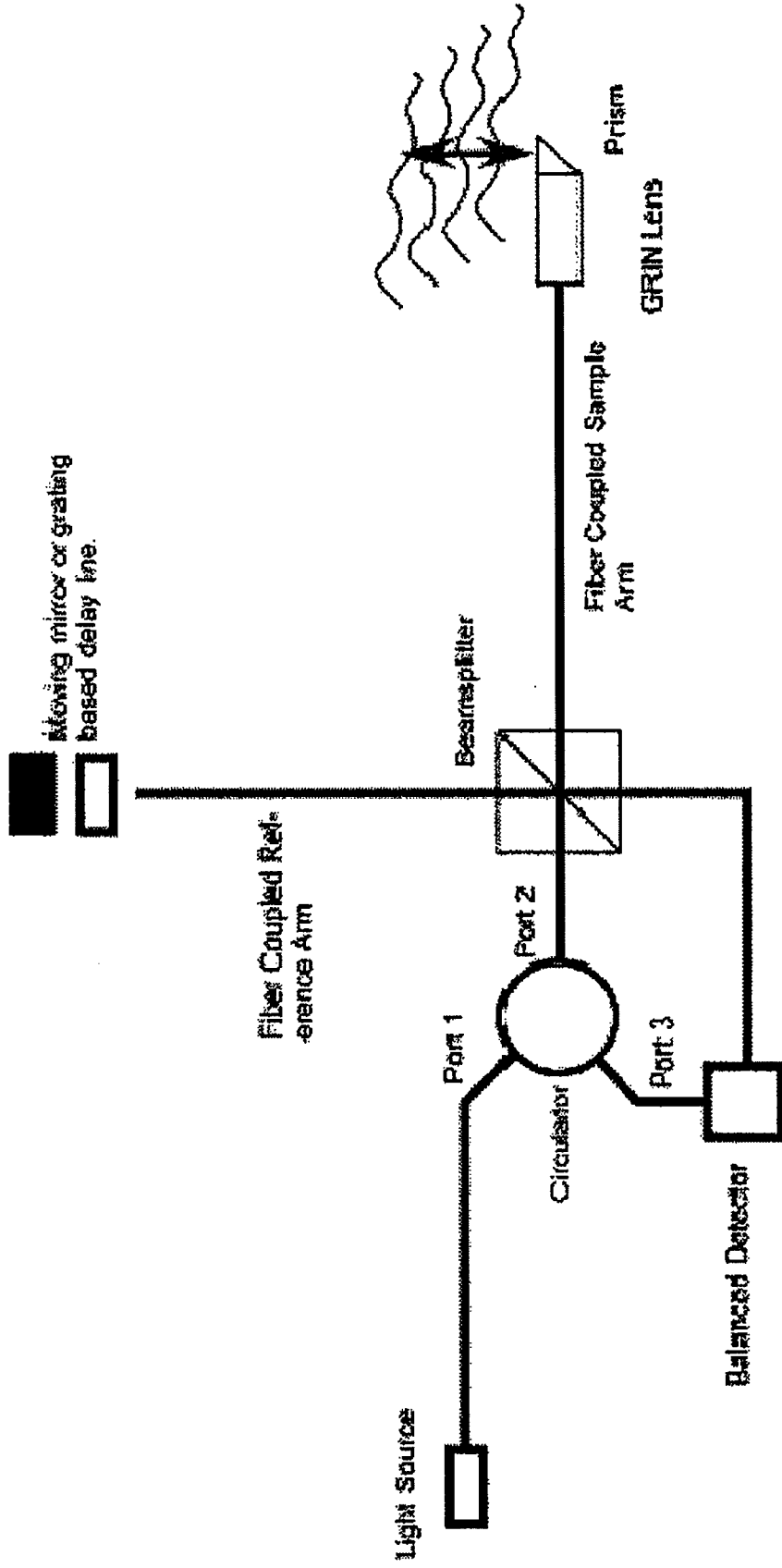
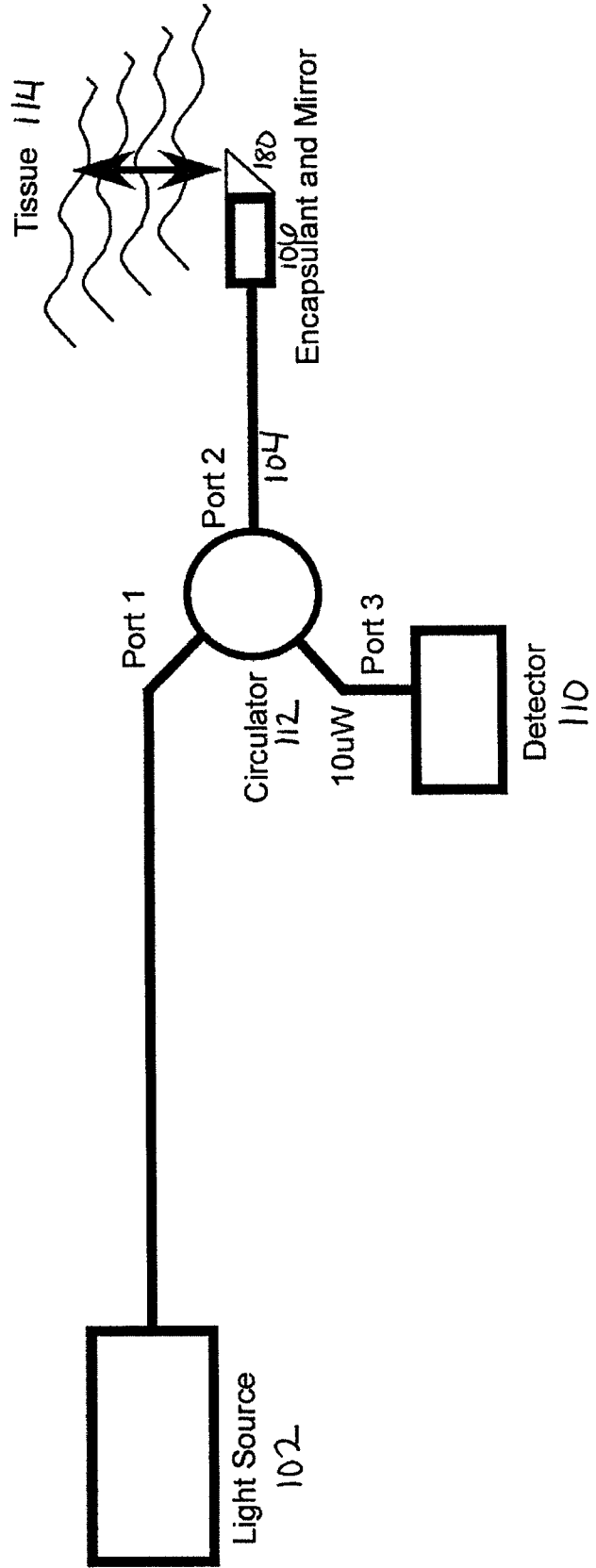

Figure 1 - Prior Art

FIG. 2A

100  
↓



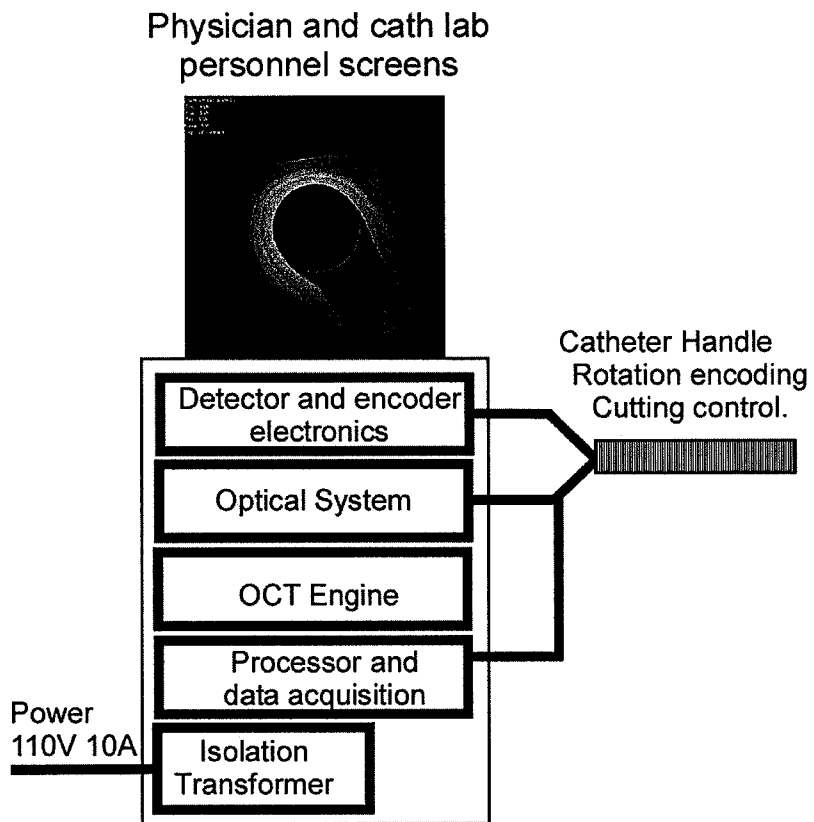

FIG. 2B



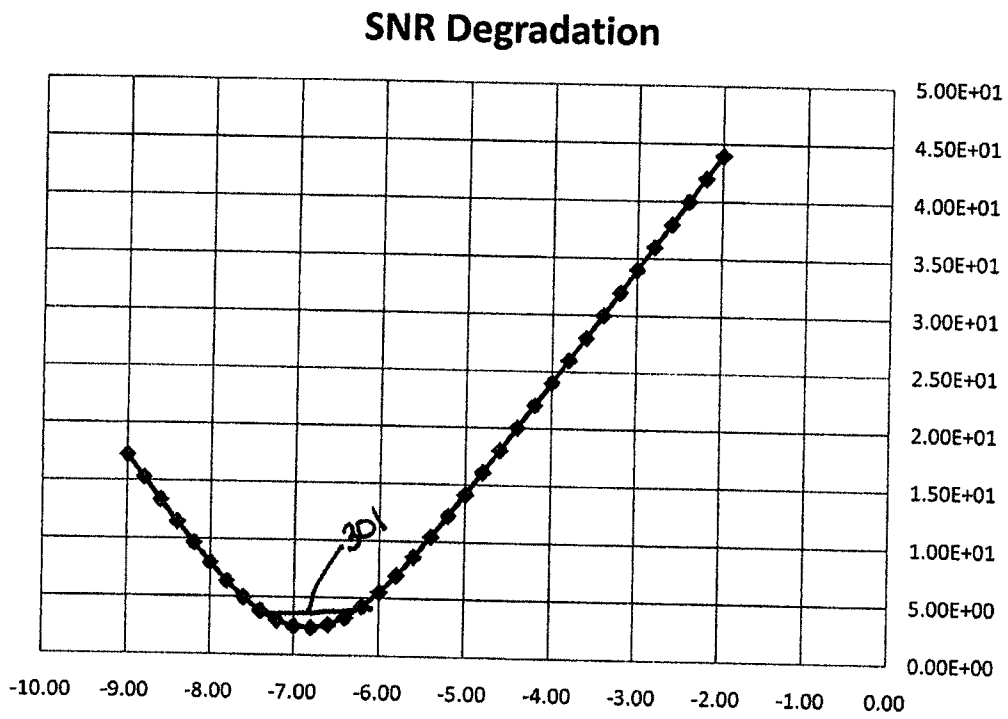

FIG. 3A

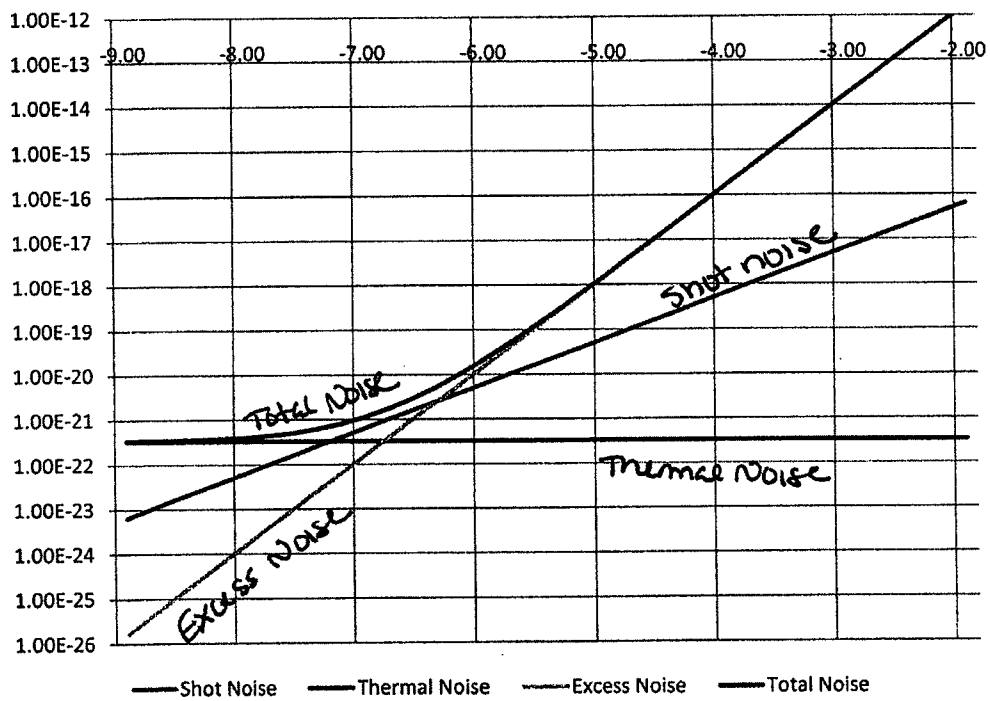

FIG. 3B

Log Ref Power	Ref Power	Sample Power	Shot Noise	Thermal Noise	Excess Noise	Total Noise	SNR	SNR (dB)	SNL-SNR	(dB)	SNR Degradation
-7.60	2.51E-08	2.5E-09	1.61E-22	3.31E-22	1.01E-23	5.02E-22	2.50E+05	5.40E+01	7.80E+05	5.89E+01	4.94E+00
-7.40	3.98E-08	2.5E-09	2.55E-22	3.31E-22	2.54E-23	6.12E-22	3.25E+05	5.51E+01	7.80E+05	5.89E+01	3.80E+00
-7.20	6.31E-08	2.5E-09	4.04E-22	3.31E-22	6.38E-23	7.99E-22	3.95E+05	5.60E+01	7.80E+05	5.89E+01	2.96E+00
-7.00	1.00E-07	2.5E-09	6.41E-22	3.31E-22	1.60E-22	1.13E-21	4.42E+05	5.64E+01	7.80E+05	5.89E+01	2.47E+00
-6.80	1.58E-07	2.5E-09	1.02E-21	3.31E-22	4.03E-22	1.75E-21	4.53E+05	5.66E+01	7.80E+05	5.89E+01	2.36E+00
-6.60	2.51E-07	2.5E-09	1.61E-21	3.31E-22	1.01E-21	2.95E-21	4.25E+05	5.63E+01	7.80E+05	5.89E+01	2.63E+00
-6.40	3.98E-07	2.5E-09	2.55E-21	3.31E-22	2.54E-21	5.42E-21	3.67E+05	5.56E+01	7.80E+05	5.89E+01	3.27E+00
-6.20	6.31E-07	2.5E-09	4.04E-21	3.31E-22	6.38E-21	1.08E-20	2.93E+05	5.47E+01	7.80E+05	5.89E+01	4.25E+00

FIG. 3C

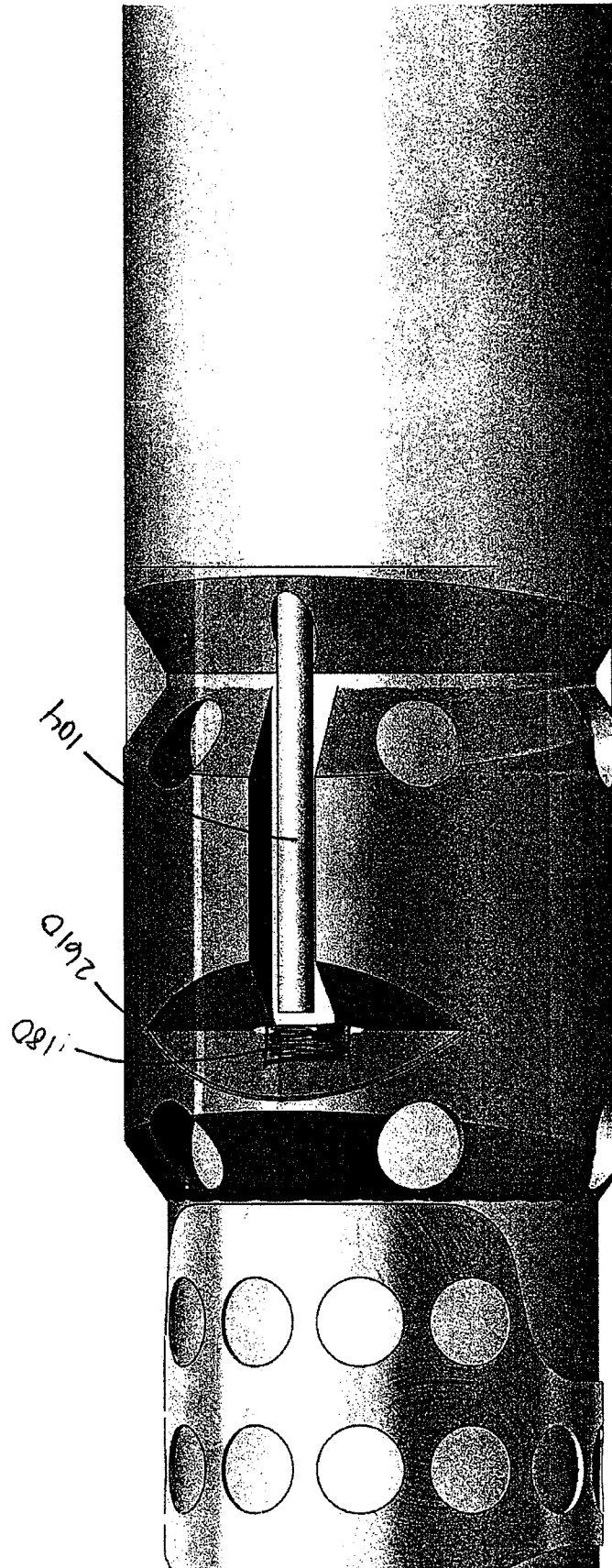

Figure 4A

8/17

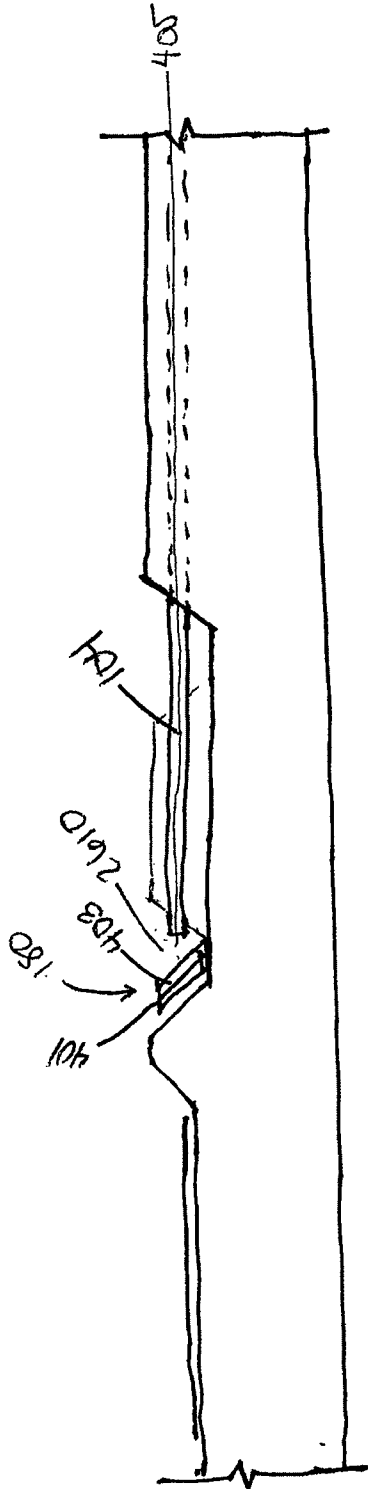
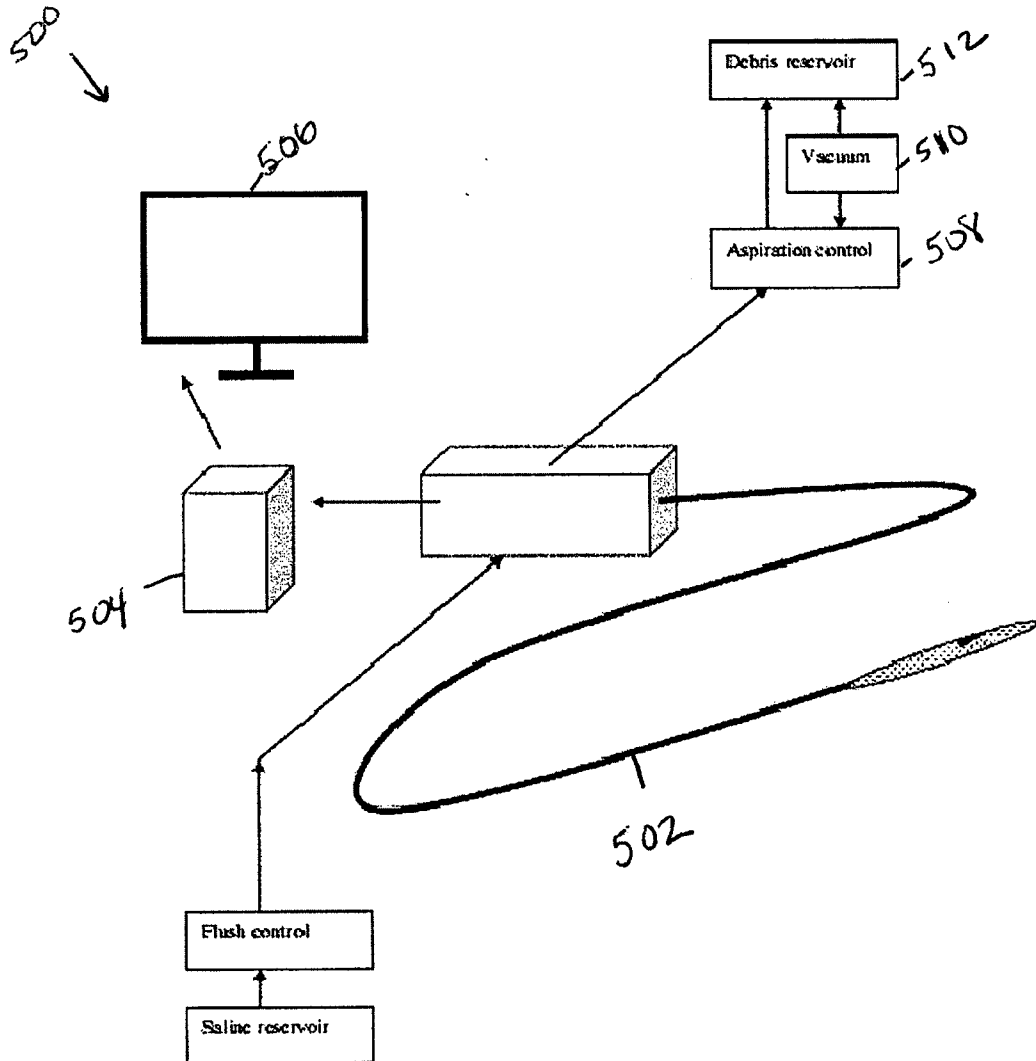

Figure 4B

9/17

Figure 5



10/17

Figure 6A

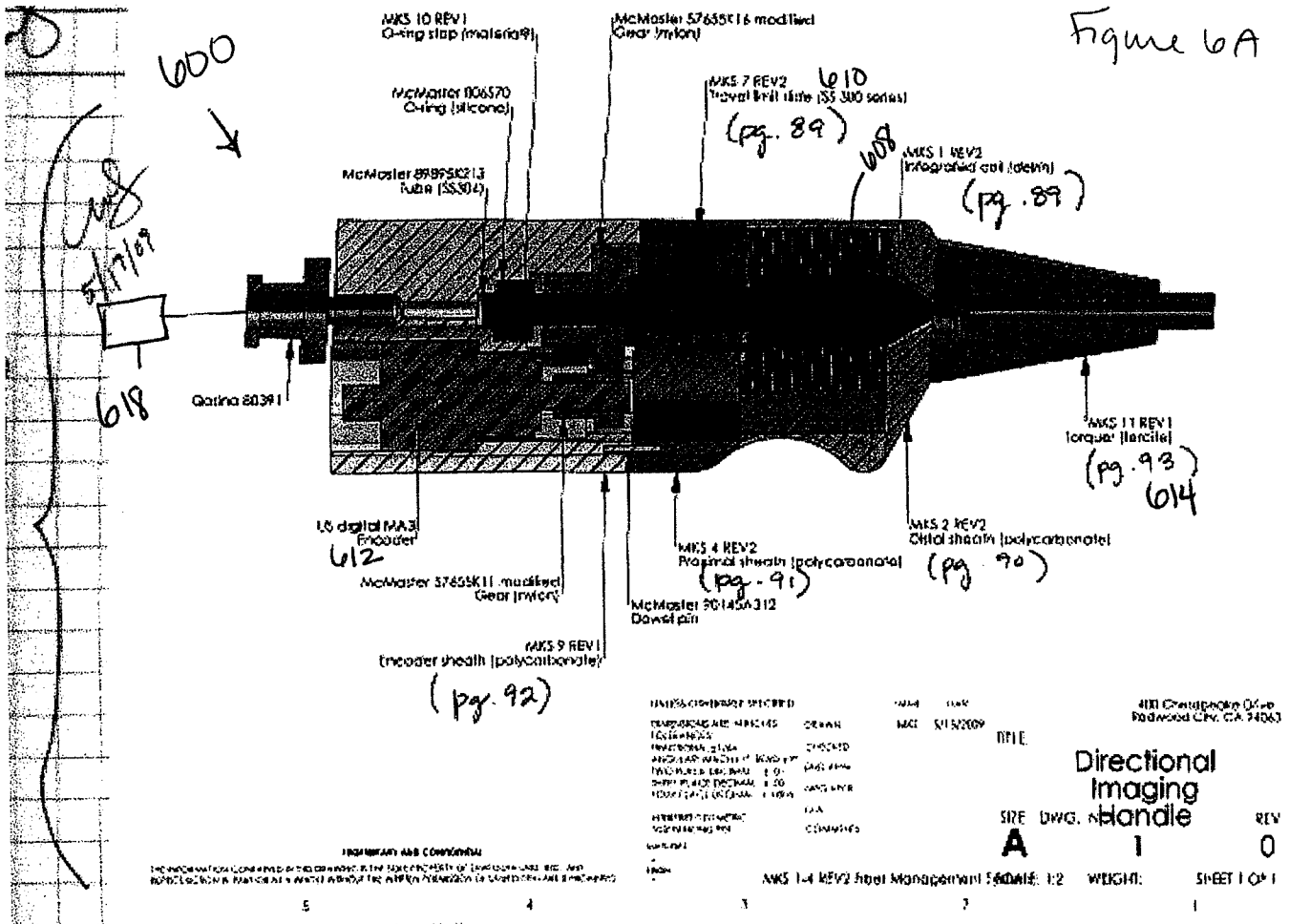

11/17

Figure 6B

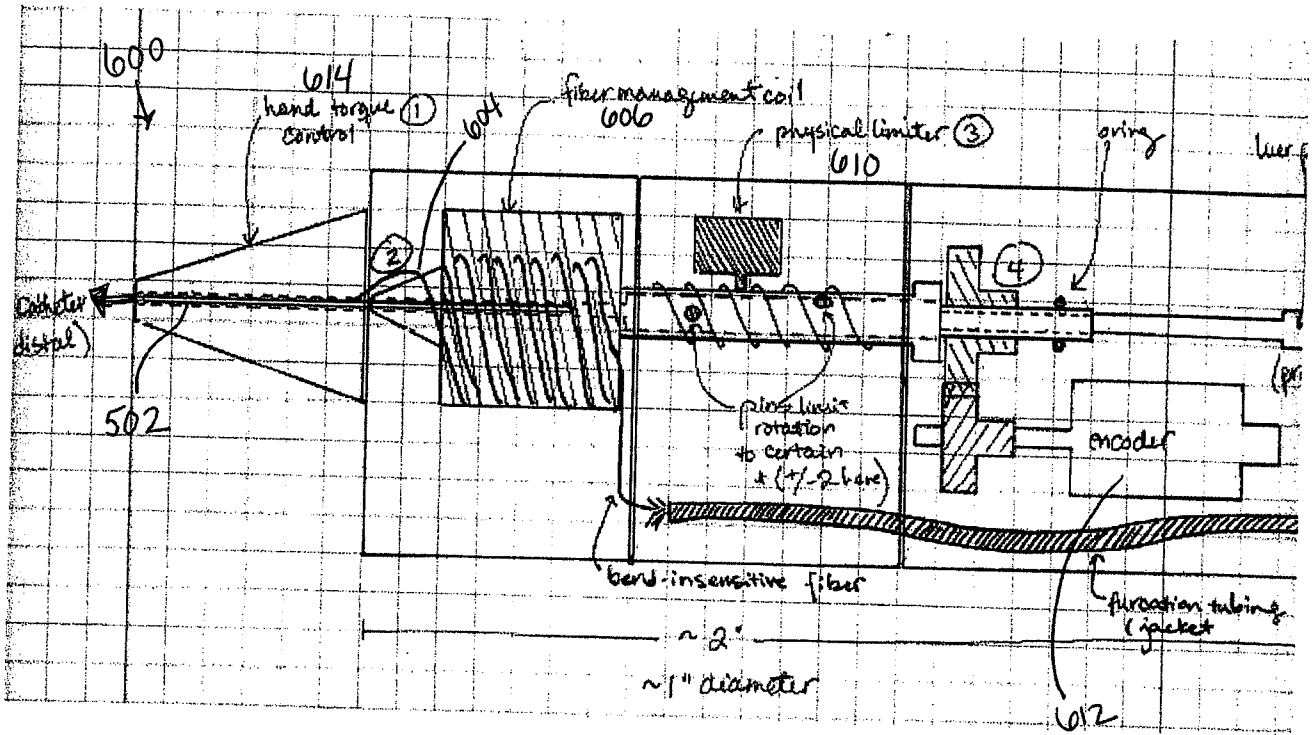



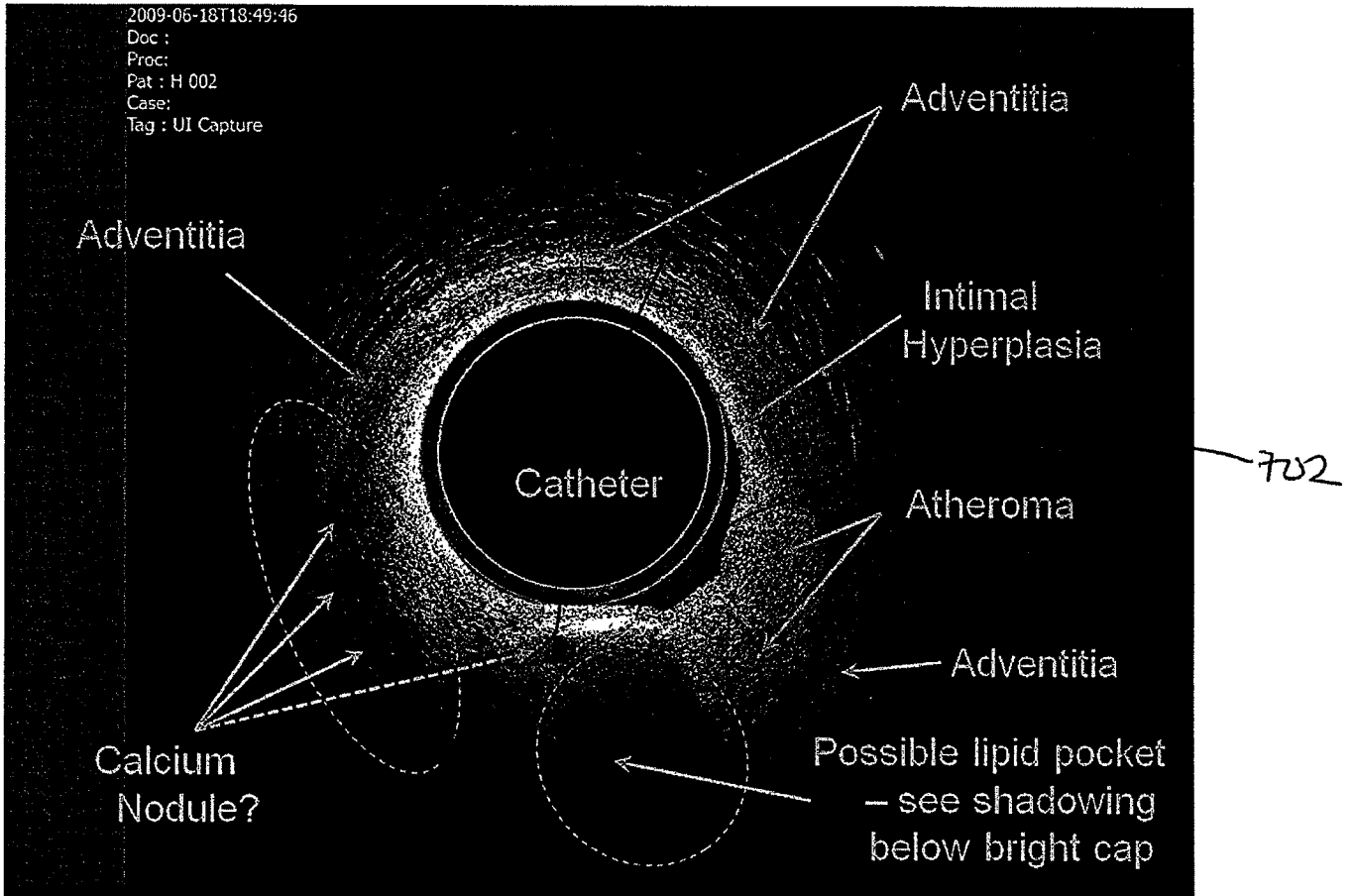

502 Figure 7

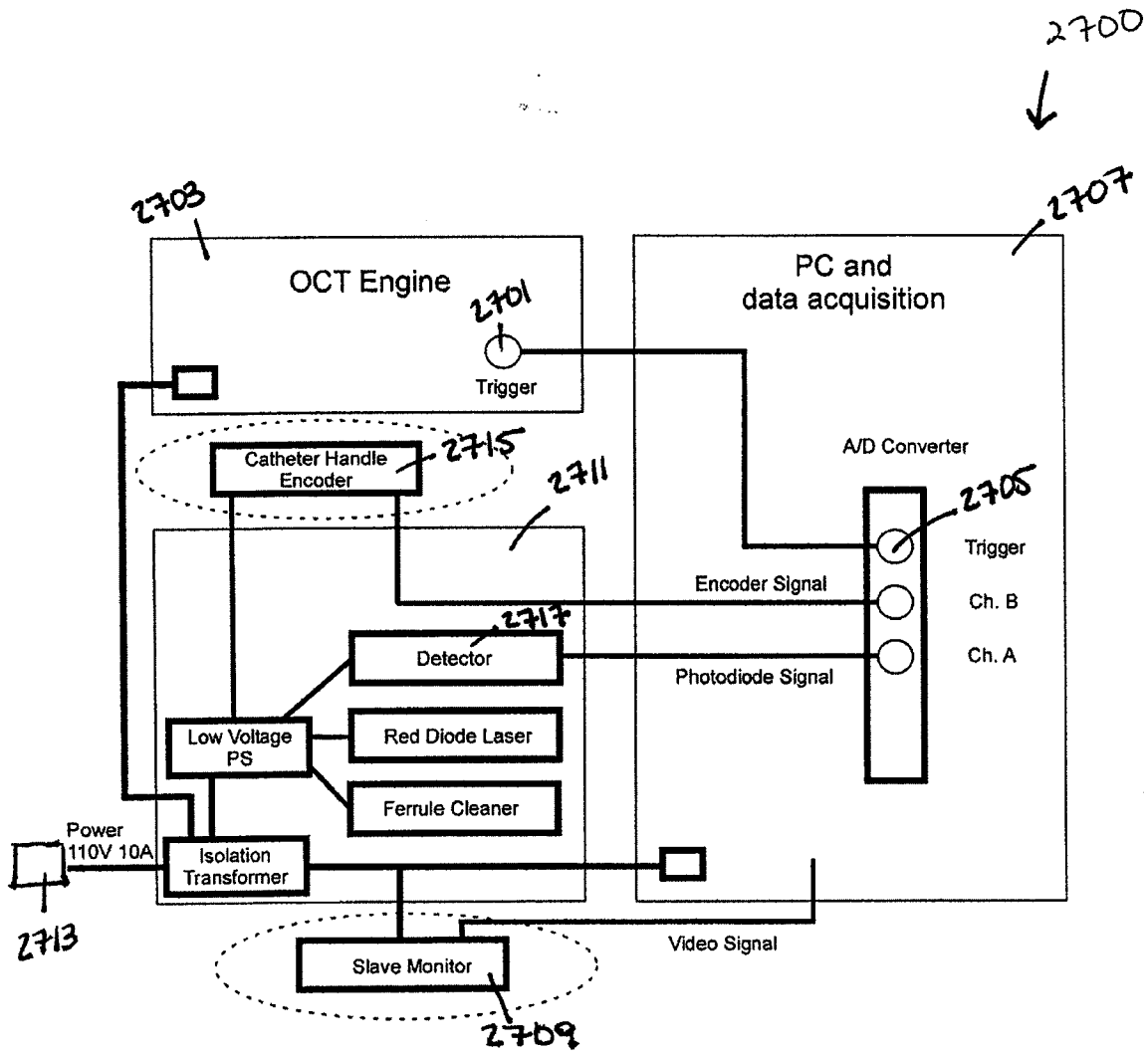

FIG. 8

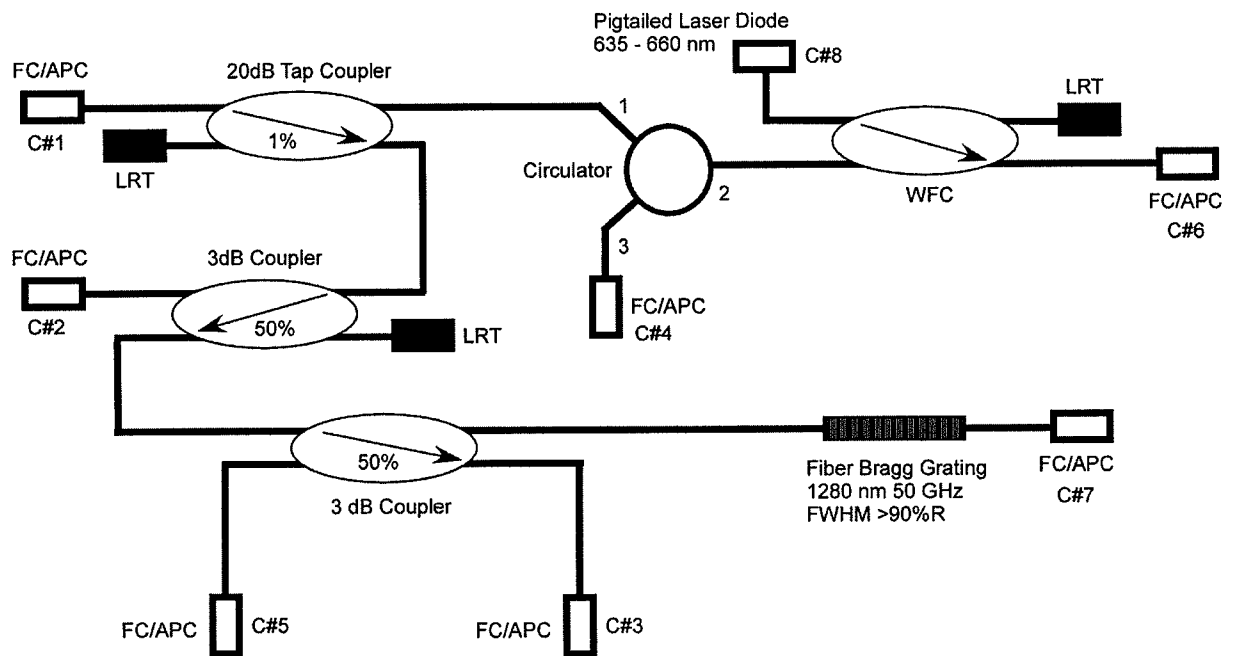

FIG. 9

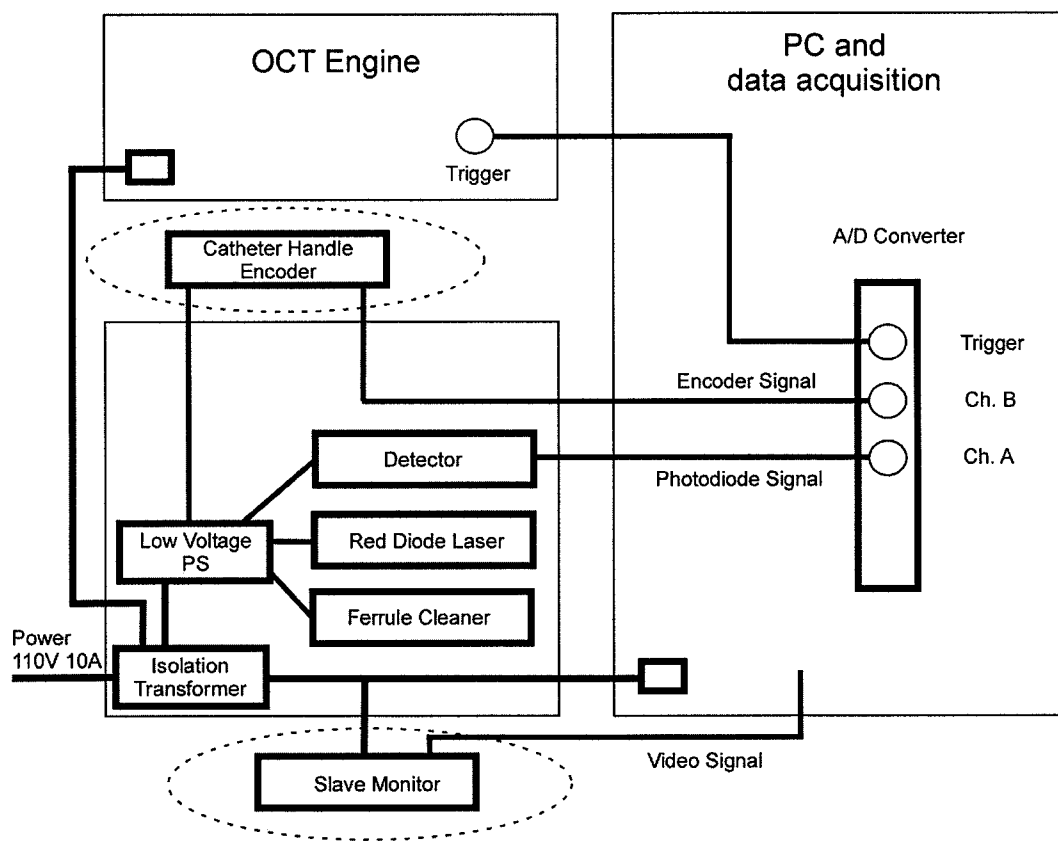

FIG. 10

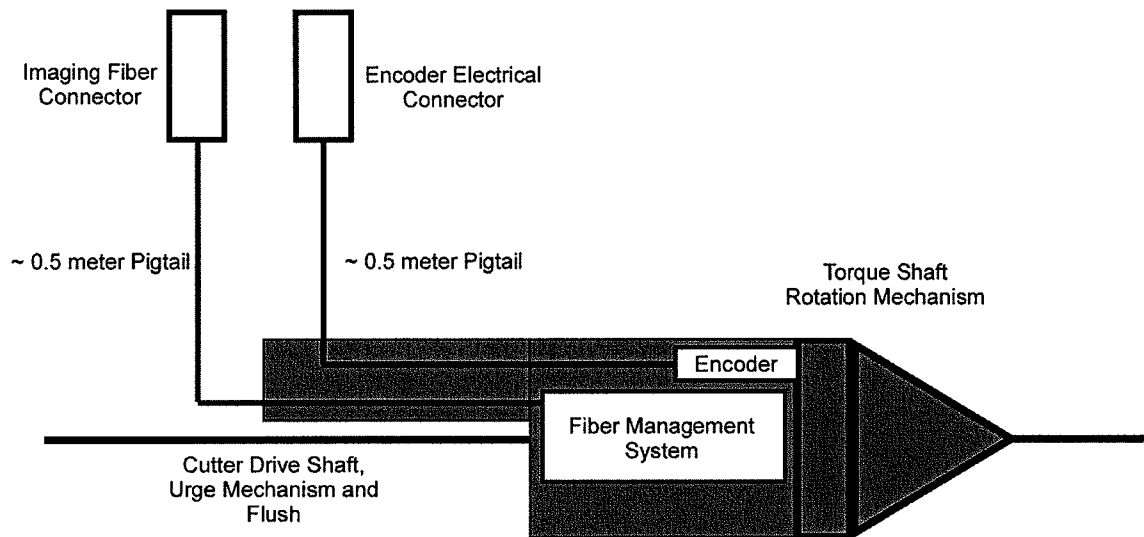

FIG. 11

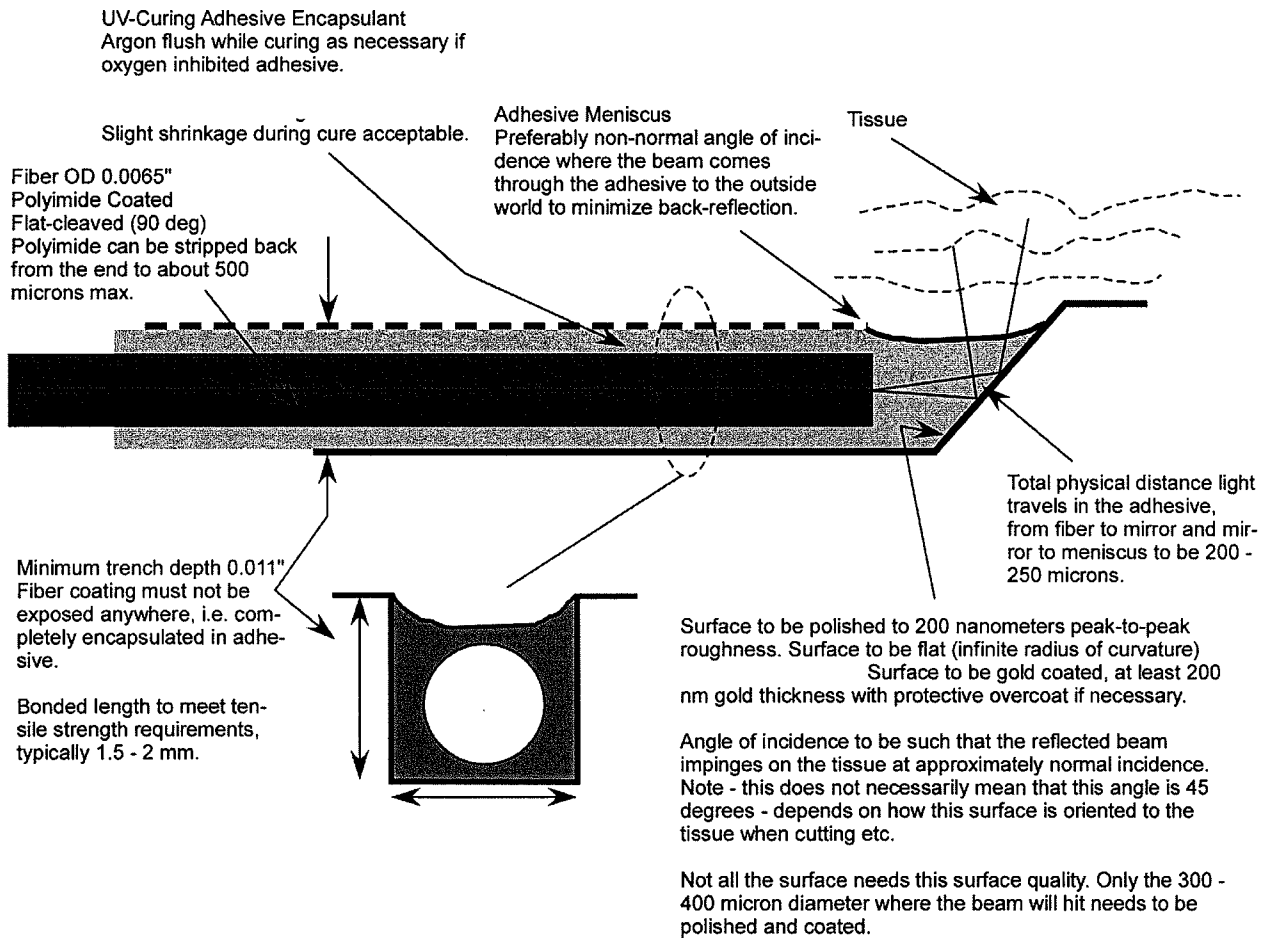

FIG. 12