

(19) World Intellectual Property Organization
International Bureau



(43) International Publication Date
27 July 2006 (27.07.2006)

PCT

(10) International Publication Number
WO 2006/078105 A1

- (51) International Patent Classification: [KR/KR]; B-501 Samho greenville, 337-28 Bisan-dong, Dongan-gu, Anyang-si, Gyeonggi-do 431-060 (KR).
G01M 3/40 (2006.01)
- (21) International Application Number: (74) Agent: **KONG, Seok-kyun**; #5 Wooyoung Bldg. 637-20 Yeoksam-dong, Gangnam-gu, Seoul 135-909 (KR).
PCT/KR2006/000110
- (22) International Filing Date: 11 January 2006 (11.01.2006)
- (25) Filing Language: English
- (26) Publication Language: English
- (30) Priority Data: (81) Designated States (unless otherwise indicated, for every kind of national protection available): AE, AG, AL, AM, AT, AU, AZ, BA, BB, BG, BR, BW, BY, BZ, CA, CH, CN, CO, CR, CU, CZ, DE, DK, DM, DZ, EC, EE, EG, ES, FI, GB, GD, GE, GH, GM, HR, HU, ID, IL, IN, IS, JP, KE, KG, KM, KN, KP, KZ, LC, LK, LR, LS, LT, LU, LV, LY, MA, MD, MG, MK, MN, MW, MX, MZ, NA, NG, NI, NO, NZ, OM, PG, PH, PL, PT, RO, RU, SC, SD, SE, SG, SK, SL, SM, SY, TJ, TM, TN, TR, TT, TZ, UA, UG, US, UZ, VC, VN, YU, ZA, ZM, ZW.
10-2005-0004808 19 January 2005 (19.01.2005) KR
- (71) Applicant (for all designated States except US): **RECHNER KOREA CO., LTD** [KR/KR]; 7605 Dongilltechnotown 7-cha, Gwanyang-dong, Dongan-gu, Anyang-si, Gyeonggi-do 431-060 (KR).
- (72) Inventor; and
- (75) Inventor/Applicant (for US only): **PAK, Jong-ku**
- (84) Designated States (unless otherwise indicated, for every kind of regional protection available): ARIPO (BW, GH, GM, KE, LS, MW, MZ, NA, SD, SL, SZ, TZ, UG, ZM, ZW), Eurasian (AM, AZ, BY, KG, KZ, MD, RU, TJ, TM), European (AT, BE, BG, CH, CY, CZ, DE, DK, EE, ES, FI,

[Continued on next page]

(54) Title: CAPACITANCE TYPE LEAKAGE SENSOR

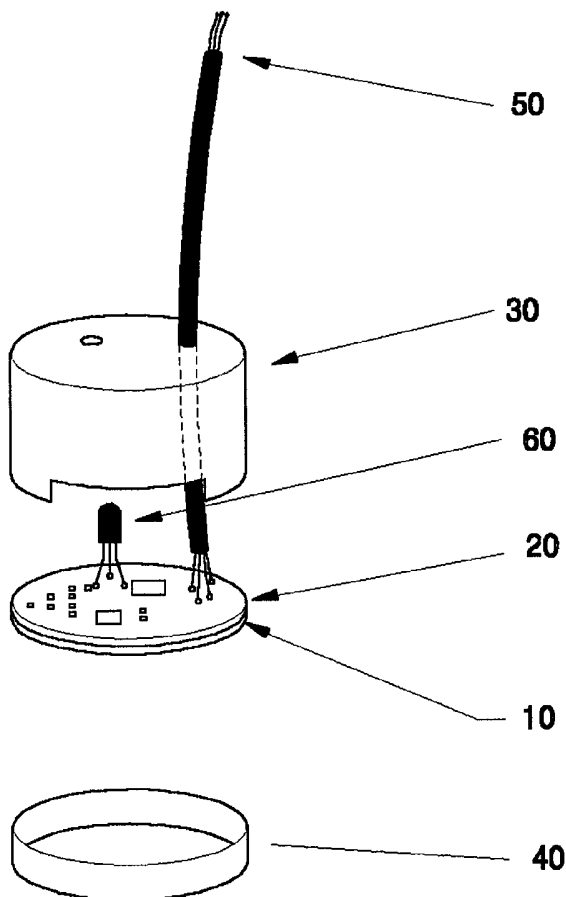

(57) Abstract: The present invention relates to a leakage sensor for sensing leakage of water and chemical liquid, and more particularly, to a capacitance type leakage sensor for sensing leakage of water and chemical liquid to prevent the leakage in semiconductor, LCD and industrial equipment. The present invention provides a reliable leakage sensor for sensing leakage of chemicals or water using characteristic of a capacitance type sensor to prevent an erroneous operation caused by a variation in the intensity of illumination and avoid an inconvenience of having to replace a liquid-absorbing paper for sensing the variation in the intensity of illumination. A board circuit part and a sensing part of the leakage sensor are integrated in a two-sided (multi-layered) board structure to minimize the leakage sensor. Accordingly, the leakage sensor can be applied to semiconductor and LCD equipment having a small mounting space.

WO 2006/078105 A1



FR, GB, GR, HU, IE, IS, IT, LT, LU, LV, MC, NL, PL, PT,
RO, SE, SI, SK, TR), OAPI (BF, BJ, CF, CG, CI, CM, GA,
GN, GQ, GW, ML, MR, NE, SN, TD, TG).

For two-letter codes and other abbreviations, refer to the "Guidance Notes on Codes and Abbreviations" appearing at the beginning of each regular issue of the PCT Gazette.

Published:

— *with international search report*

CAPACITANCE TYPE LEAKAGE SENSOR**Technical Field**

The present invention relates to a leakage sensor for
5 sensing leakage of water and chemical liquid, and more
particularly, to a capacitance type leakage sensor for
sensing leakage of water and chemical liquid to prevent the
leakage in semiconductor, LCD and industrial equipment.

10 Background Art

Water and chemicals are used for various purposes in
industrial equipment. When water or chemicals are leaked,
expensive apparatuses are damaged and the chemicals can
threaten human life. Accordingly, a leakage sensor is set
15 in the industrial equipment to sense leakage of water or
chemicals.

Most of conventional leakage sensors are photo sensors
using lights. A photo sensor is constructed in a manner
that a liquid-absorbing paper reflecting light is disposed
20 at the bottom of the sensor and leakage is sensed according
to intensity of illumination of light reflected by the
liquid-absorbing paper. When the liquid-absorbing paper
absorbs water or chemicals, the intensity of illumination
of the liquid-absorbing paper is varied. Then, this
25 variation is sensed and converted into a signal to sense
leakage of water or chemicals.

In the aforementioned conventional photo sensor, the
liquid-absorbing paper should be replaced whenever leakage
occurs. Furthermore, the intensity of illumination may vary
30 due to moisture and chemicals in the air after a
predetermined lapse of time from when the sensor is
installed to result in an erroneous operation.

Accordingly, there is an inconvenience of having to set a wet paper having good white absorptiveness in a sensing part all the time to maintain uniform intensity of illumination in the conventional leakage sensor. Furthermore, probability of generation of an erroneous operation is high in the case of chemicals having a small variation in the intensity of illumination.

Disclosure of Invention

Accordingly, the present invention provides a reliable leakage sensor for sensing leakage of chemicals or water using characteristic of a capacitance type sensor to prevent an erroneous operation caused by a variation in the intensity of illumination and avoid an inconvenience of having to replace a liquid-absorbing paper for sensing the variation in the intensity of illumination.

The present invention also provides a leakage sensor constructed in a manner that a board circuit part and a sensing part are integrated in a two-sided (multi-layered) board structure to minimize the leakage sensor such that the leakage sensor can be applied to semiconductor and LCD equipment having a small mounting space.

The present invention provides a capacitance type leakage sensor capable of sensing leakage using a dielectric constant varied due to leaked liquid such as water or chemicals infiltrated into a sensor housing.

The capacitance type leakage sensor includes a sensor board having pole plates generating sensor fields for detecting a variation in a dielectric constant due to leaked liquid, a circuit board including processing components for detecting a current variation in response to the dielectric constant between the pole plates, which is

varied according to the leaked liquid placed in the sensor fields passing through a case to be extended to the outside, amplifying the detected current variation and outputting the amplified current variation, the case that houses and
5 protects the sensor board and is sealed up such that the leaked liquid is not infiltrated thereinto from the outside, and a cable extended to the outside through the case to transmit the output signal of the circuit board and supply operating power to the circuit board.

10 The circuit board and the sensor board are constructed in a two-sided board or a multi-layer board to reduce the area of the components inside the housing to miniaturize the leakage sensor.

15 **Brief Description of the Drawings**

Further objects and advantages of the invention can be more fully understood from the following detailed description taken in conjunction with the accompanying drawings, in which:

20 FIG. 1 is an exploded perspective view of a capacitance type leakage sensor according to an embodiment of the present invention;

FIG. 2 is an exploded perspective view of a capacitance type leakage sensor according to another
25 embodiment of the present invention;

FIG. 3 is a block diagram of a circuit of a circuit board for sensing leakage;

FIG. 4a illustrates an example of setting a sensor using a metal holder;

30 FIG. 4b illustrates an example of setting a sensor using a nonmetal holder; and

FIG. 5 illustrates a capacitance type sensor field

applied to the present invention.

Best Mode for Carrying Out the Invention

The present invention will now be described in detail
5 in connection with preferred embodiments with reference to
the accompanying drawings. For reference, like reference
characters designate corresponding parts throughout several
views.

A capacitance type leakage sensor according to the
10 present invention includes a sensor board 10 on which pole
plates generating sensor fields for detecting a variation
in a dielectric constant in response to leaked liquid is
mounted, a circuit board 20 having processing components
15 constant between the pole plates mounted on the sensor
board 10 in response to the leaked liquid coming into
contact with the sensor board 10, converting the sensed
current variation into a signal and outputting the
converted signal, a housing 30 and a protection cover 40
20 for protecting the sensor board 10 and the circuit board 20.
A cable 50 is connected to the circuit board 20 through the
housing 30 to supply power to the circuit board 20 and
transmits the output signal of the circuit board 20.

In addition, a light-emitting diode 60 is mounted on
25 the circuit board 20 as an indicator for indicating the
operating state of the sensor. Furthermore, a structure for
exposing the light-emitting diode 60 to the outside is
formed at a portion of the housing 30, which corresponds to
the light-emitting diode 60. For example, a transparent
30 window is formed in the housing 30 such that the light-
emitting diode 60 can be seen through the transparent
window.

As described above, the capacitance type leakage sensor of the present invention includes the sensor board 10 having the pole plates for sensing leaked liquid and the circuit board 20 for detecting a dielectric constant variation through the sensor board 10 to sense whether leakage is generated or not.

The sensor board 10 and the circuit board 20 can be integrated in a two-sided board structure or a multi-layered board structure to miniaturize the leakage sensor. The sensor board 10 and the circuit board 20 can be separated from each other, as illustrated in FIG. 2.

The housing 30 and the protection cover 40 house the sensor board 10 and the circuit board 20 in such a manner that the pole plates of the sensor board 10 face the protection cover 40, that is, a place in which leaked liquid is collected.

Because external liquid is sensed while the sensor board 10 is housed in the housing 30 and the protection cover 40, the housing 30 and the protection cover 40 are made using a fluorine resin such as Teflon (PTFE), which has a small dielectric constant and is robust to leaked water or chemical liquid, as a basic material. PE, PVC, PC and PEEK can be also used for the housing 30 and the protection cover 40. The fluorine resin includes PFA and PVDF in addition to Teflon. PE or PVC is used according to the kinds of chemicals to be sensed because the Teflon is expensive.

Special epoxy is filled in the housing 30 and the protection cover 40 to prevent the leakage sensor from being floated due to its own weight even when a large amount of liquid is leaked. Furthermore, the special epoxy prevents leaked liquid from infiltrating into the housing

30 to improve the durability of the leakage sensor.

The circuit board 20 includes an RF oscillator, a detector, an amplifier and an output circuit. The circuit board 20 amplifies a current varied with a change in the dielectric constant between the pole plates mounted on the sensor board 10 and outputs the amplified current through the cable 50.

FIG. 3 is a block diagram of the circuit board 20.

The inside of the leakage sensor of the present invention is filled with epoxy and sealed up such that any liquid cannot infiltrate into the sensor from the outside. As shown in FIGS. 4a and 4b, the leakage sensor is installed in a place where leaked liquid is collected using holders 70 and 71 that are fixing means. The holders 70 and 71 can be made of a metal as shown in FIG. 4a or Teflon (PTFE) or PVC as shown in FIG. 4b.

The leakage sensor of the present invention having the above-described configuration uses the dielectric constant of a material. All of natural materials have their own dielectric constants. For example, air, plastic material, glass, water and alcohol respectively have dielectric constants of 1, 2, 6, 81 and 25. All the materials other than air can be sensed using their dielectric constants. The present invention senses materials having dielectric constants larger than the dielectric constant of air.

The present invention constructs the leakage sensor that senses a variation in the dielectric constant of a material in response to a change in the distance between the material and an electrode. When a dielectric (metal or nonmetal) becomes close to the electrode, polarization occurs in the dielectric to increase the dielectric constant. Accordingly, the leakage sensor of the present

invention senses a variation in the dielectric constant and amplifies the variation to sense leakage.

FIG. 5 illustrates a sensor field for explaining the capacitance type leakage sensor of the present invention.

5 When leaked liquid is collected at the bottom part of the sensor installed in a place where the leaked liquid can be collected and flows into the protection cover 40, a dielectric constant between sensor fields of two pole plates set in the direction of the bottom part of the
10 sensor board 10, that is, the protection cover 40, is varied. Here, the leaked liquid may not come into contact with the protection cover 40.

As described above, the housing 30 and the protection cover 40 are made of materials having very small dielectric
15 constants. Even when the housing 30 and the protection cover 40 have dielectric constants that are directly detected, the sensitivity of the sensor can be controlled in consideration of the dielectric constants of the housing
30 and the protection cover 40.

20 The circuit board 20 detects a current in response to the dielectric constant varied according to leaked liquid infiltrated between the sensor fields of the two pole plates. The dielectric constant between the two pole plates is varied according to whether liquid is leaked or not and
25 a current detected in response to this variation is also changed. The circuit board 20 amplifies the changed current, outputs the amplified current and transmits it to a main center. Accordingly, the main center judges whether liquid is leaked in the place where the sensor is installed.

30 As described above, the present invention provides a leakage sensor capable of sensing chemicals or water using the characteristic of the capacitance type sensor. A means

for sensing leakage (board) and a circuit for processing leakage (board) can be integrated in a two-sided or multi-layered board structure to miniaturize the leakage sensor. Thus, the leakage sensor can be easily set and a place
5 where the sensor is set is less restricted. Accordingly, the leakage sensor can be applied to semiconductor and LCD equipment.

Furthermore, the leakage sensor of the present invention does not require a liquid-absorbing paper, and
10 thus an inconvenience of having to replace the liquid-absorbing paper can be avoided. Moreover, the leakage sensor of the present invention is filled with special epoxy so that it is not floated due to its own weight even when a large amount of liquid is leaked. In addition,
15 chemicals cannot infiltrate into the sensor, and thus the durability of the leakage sensor is semi-permanent.

While the present invention has been described with reference to the particular illustrative embodiments, it is not to be restricted by the embodiments but only by the
20 appended claims. It is to be appreciated that those skilled in the art can change or modify the embodiments without departing from the scope and spirit of the present invention.

What Is Claimed Is:

1. A capacitance type leakage sensor comprising:
 - a sensor board having pole plates generating sensor
5 fields for detecting a variation in a dielectric constant
due to leaked liquid to be sensed;
 - a circuit board including processing components for
detecting a current variation in response to a dielectric
constant between the pole plates, which is varied in
10 response to the leaked liquid placed in the sensor fields
passing through a case to be extended to the outside,
amplifying the detected current variation and outputting
the amplified current variation;
 - the case for housing and protecting the sensor board
15 and the circuit board, the case being sealed up such that
leaked liquid is not infiltrated into the case from the
outside; and
 - a cable extended to the outside through the case to
transmit the output signal of the circuit board and supply
20 operating power to the circuit board.
2. The capacitance type leakage sensor as claimed
in claim 1, further comprising an indicating means for
indicating the operating state of the leakage sensor, the
25 case having a structure that can expose the indicating
means such that the indicating means can be seen from the
outside.
3. The capacitance type leakage sensor as claimed
30 in claim 1, wherein the case includes a protection cover
for protecting the sensor board, and a housing placed on
the protection cover to house the circuit board and the

sensor board.

4. The capacitance type leakage sensor as claimed in claim 3, wherein the pole plates mounted on the sensor board include two positive pole plates, and the pole plates are arranged to face the protection cover such that the sensor fields are generated while passing through the protection cover.

10 5. The capacitance type leakage sensor as claimed in any one of claims 1 to 4, wherein the circuit board and the sensor board are constructed in a two-sided board or a multi-layer board.

15 6. The capacitance type leakage sensor as claimed in any one of claims 1 to 4, wherein the case is filled with epoxy.

1 / 5

FIG. 1

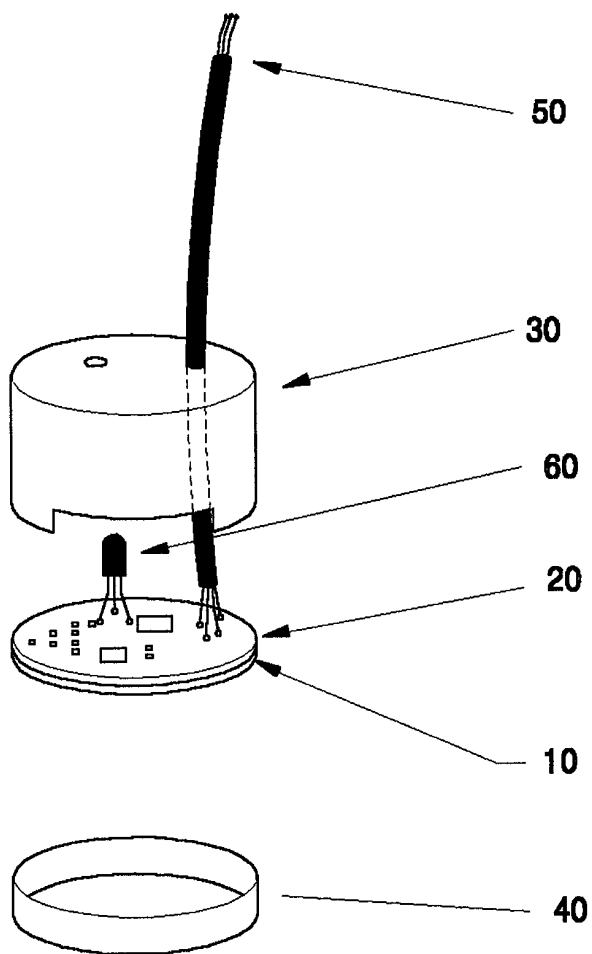

2 / 5

FIG. 2

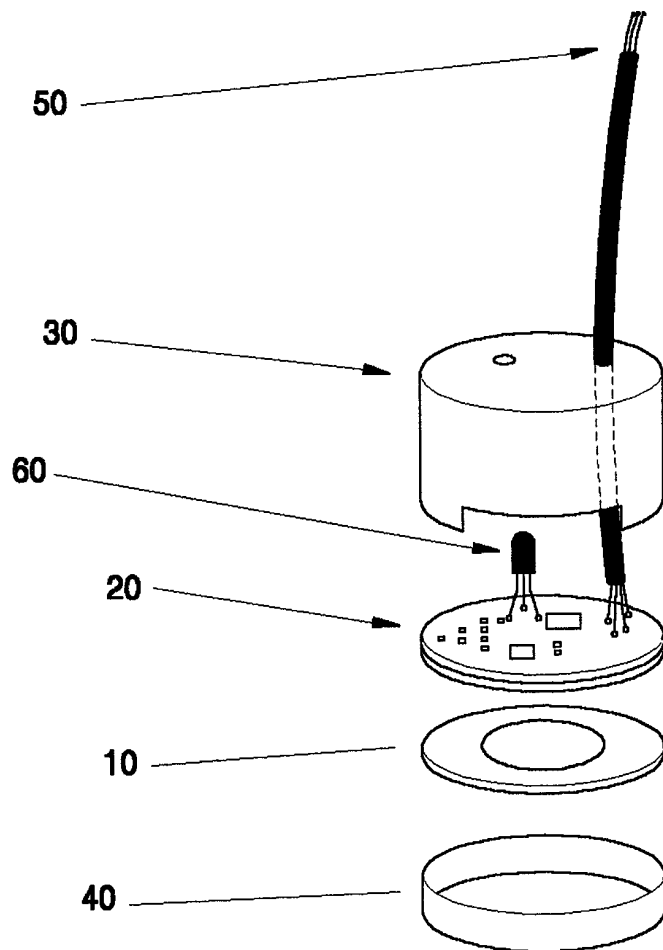

3 / 5

FIG. 3

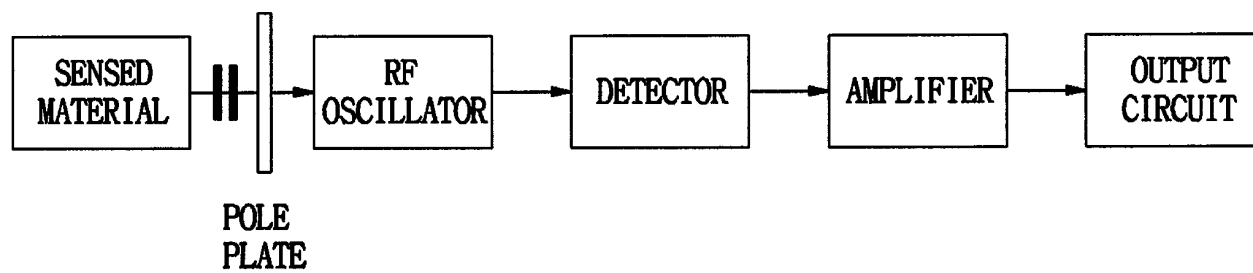
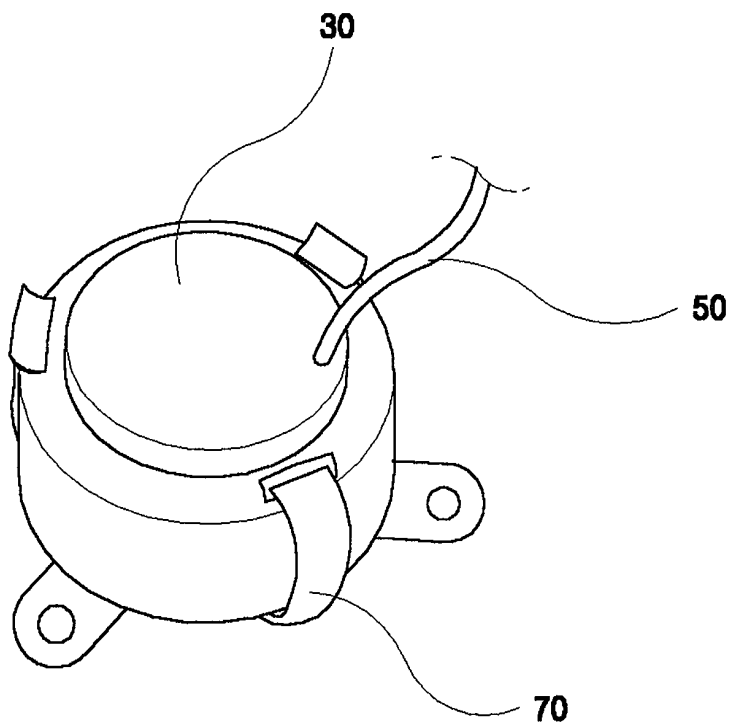

FIG. 4a



4 / 5

FIG. 4b

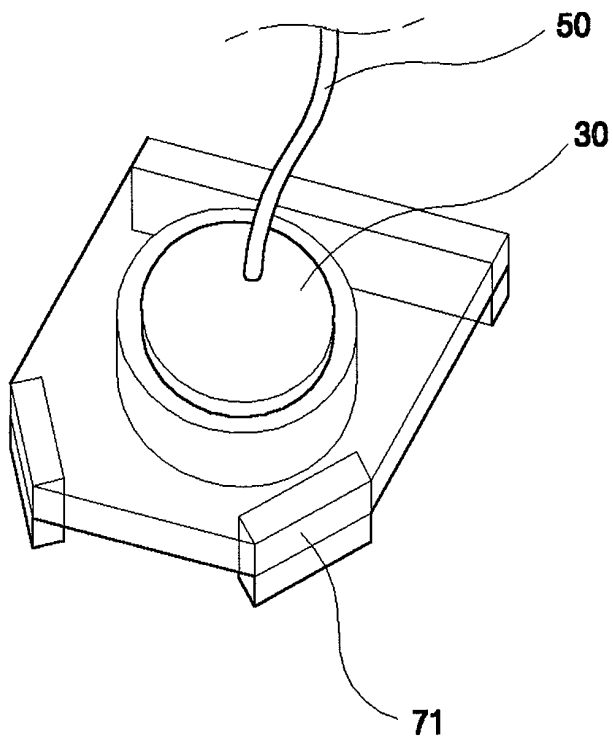
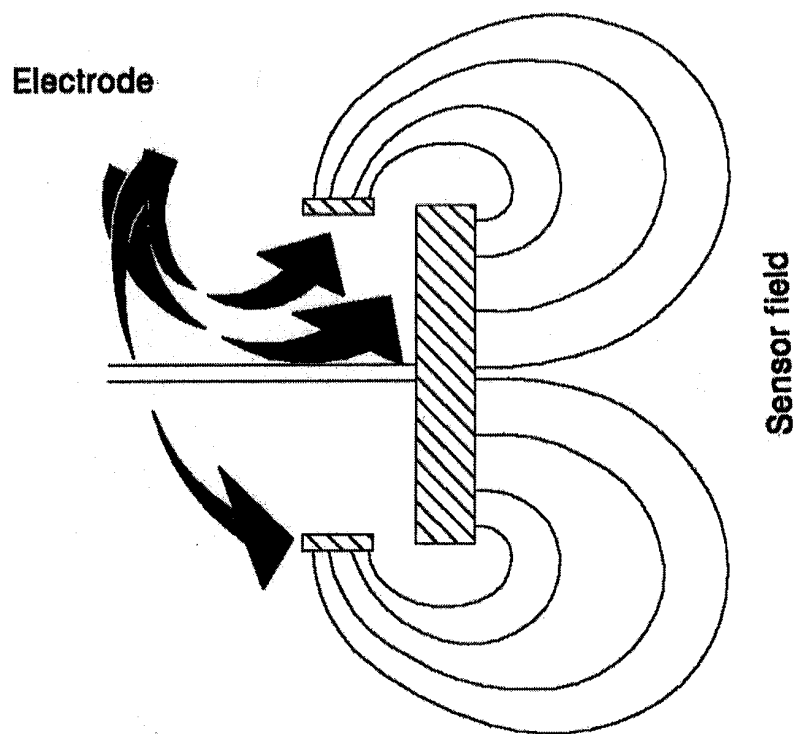

FIG. 5



INTERNATIONAL SEARCH REPORT

International application No.
PCT/KR2006/000110

A. CLASSIFICATION OF SUBJECT MATTER				
<i>G01M 3/40(2006.01)i</i>				
According to International Patent Classification (IPC) or to both national classification and IPC				
B. FIELDS SEARCHED				
Minimum documentation searched (classification system followed by classification symbols) G01M 3/40 IPC8				
Documentation searched other than minimum documentation to the extent that such documents are included in the fields searched KR, JP as above IPC				
Electronic data base consulted during the international search (name of data base and, where practicable, search terms used) KIPONET, "capacitive", "leak", "water", "liquid", "sensor", "diode", "alarm"				
C. DOCUMENTS CONSIDERED TO BE RELEVANT				
Category*	Citation of document, with indication, where appropriate, of the relevant passages	Relevant to claim No.		
Y	US 5017909A (Standex International Corp) 21 May 1991 see the abstract, claims 1-16	1-5		
Y	US 5402075A(Prospects Corp) 28 Mar 1995 see the abstract, claims 1-25	1-5		
Y	US 5642098A(OEMS Corp) 24 June 1997 see the abstract	1-5		
A	US 6269693B1(Daimler-Chrysler AG) 07 Aug 2001 see the whole documents	1-6		
A	US 6742387B2(Denso Corp) 01 Jun 2004 see the whole documents	1-6		
A	US 5075816(vaisala Oy) 24 Dec 1991 see the whole documents	1-6		
A	US 5012683(E.I. Dupont de Nemours and Company) 07 May 1991 see the whole documents	1-6		
<input checked="" type="checkbox"/> Further documents are listed in the continuation of Box C. <input checked="" type="checkbox"/> See patent family annex.				
<table style="width: 100%; border: none;"> <tr> <td style="width: 50%; border: none; vertical-align: top;"> * Special categories of cited documents: "A" document defining the general state of the art which is not considered to be of particular relevance "E" earlier application or patent but published on or after the international filing date "L" document which may throw doubts on priority claim(s) or which is cited to establish the publication date of citation or other special reason (as specified) "O" document referring to an oral disclosure, use, exhibition or other means "P" document published prior to the international filing date but later than the priority date claimed </td> <td style="width: 50%; border: none; vertical-align: top;"> "T" later document published after the international filing date or priority date and not in conflict with the application but cited to understand the principle or theory underlying the invention "X" document of particular relevance; the claimed invention cannot be considered novel or cannot be considered to involve an inventive step when the document is taken alone "Y" document of particular relevance; the claimed invention cannot be considered to involve an inventive step when the document is combined with one or more other such documents, such combination being obvious to a person skilled in the art "&" document member of the same patent family </td> </tr> </table>			* Special categories of cited documents: "A" document defining the general state of the art which is not considered to be of particular relevance "E" earlier application or patent but published on or after the international filing date "L" document which may throw doubts on priority claim(s) or which is cited to establish the publication date of citation or other special reason (as specified) "O" document referring to an oral disclosure, use, exhibition or other means "P" document published prior to the international filing date but later than the priority date claimed	"T" later document published after the international filing date or priority date and not in conflict with the application but cited to understand the principle or theory underlying the invention "X" document of particular relevance; the claimed invention cannot be considered novel or cannot be considered to involve an inventive step when the document is taken alone "Y" document of particular relevance; the claimed invention cannot be considered to involve an inventive step when the document is combined with one or more other such documents, such combination being obvious to a person skilled in the art "&" document member of the same patent family
* Special categories of cited documents: "A" document defining the general state of the art which is not considered to be of particular relevance "E" earlier application or patent but published on or after the international filing date "L" document which may throw doubts on priority claim(s) or which is cited to establish the publication date of citation or other special reason (as specified) "O" document referring to an oral disclosure, use, exhibition or other means "P" document published prior to the international filing date but later than the priority date claimed	"T" later document published after the international filing date or priority date and not in conflict with the application but cited to understand the principle or theory underlying the invention "X" document of particular relevance; the claimed invention cannot be considered novel or cannot be considered to involve an inventive step when the document is taken alone "Y" document of particular relevance; the claimed invention cannot be considered to involve an inventive step when the document is combined with one or more other such documents, such combination being obvious to a person skilled in the art "&" document member of the same patent family			
Date of the actual completion of the international search 28 APRIL 2006 (28.04.2006)	Date of mailing of the international search report 28 APRIL 2006 (28.04.2006)			
Name and mailing address of the ISA/KR Korean Intellectual Property Office 920 Dunsan-dong, Seo-gu, Daejeon 302-701, Republic of Korea Facsimile No. 82-42-472-7140	Authorized officer CHUNG, Sang Tae Telephone No. 82-42-481-5497 <div style="float: right; text-align: right;"> </div>			

INTERNATIONAL SEARCH REPORT

International application No.

PCT/KR2006/000110

C (Continuation). DOCUMENTS CONSIDERED TO BE RELEVANT		
Category*	Citation of document, with indication, where appropriate, of the relevant passages	Relevant to claim No.
A	US 6647782B2(Denso Corp) 18 Nov 2003 see the whole documents	1-6

INTERNATIONAL SEARCH REPORT

Information on patent family members

International application No.

PCT/KR2006/000110

Patent document cited in search report	Publication date	Patent family member(s)	Publication date
US05017909	21.05.1991	CA2006480AA	06.07.1990
		CA2006480C	21.06.1994
		EP00377508A1	11.07.1990
		EP0377508A1	11.07.1990
		EP377508A1	11.07.1990
		JP02276918	13.11.1990
		JP2276918A2	13.11.1990
		KR1019900012089	03.08.1990
		US5017909A	21.05.1991
		US5182545A	26.01.1993
US5402075A	28.03.1995	EP614532A1	14.09.1994
		EP614532A4	26.06.1996
		JP6511561T2	22.12.1994
		US05402075	28.03.1995
		W09408247A1	14.04.1994
US05642098	24.06.1997	US5642098A	24.06.1997
US6269693B1	07.08.2001	EP1001260A1	17.05.2000
		US06269693	07.08.2001
US06742387	01.06.2004	DE10253913A1	28.05.2003
		JP15156464	30.05.2003
		JP2003156464A2	30.05.2003
		US20030094045A1	22.05.2003
		US2003094045A1	22.05.2003
		US2003094045AA	22.05.2003
		US6742387BB	01.06.2004
US05012683	07.05.1991	CA2034548AA	19.07.1991
		DE69103777C0	13.10.1994
		DE69103777T2	02.02.1995
		EP00438159A1	24.07.1991
		EP00438159B1	07.09.1994
		EP0438159A1	24.07.1991
		EP438159A1	24.07.1991
		EP438159B1	07.09.1994
		JP4218726A2	10.08.1992
		US5012683A	07.05.1991
		US06647782	18.11.2003
JP2003028824A2	29.01.2003		
US20030010119A1	16.01.2003		