

(19)



(11)

**EP 2 028 433 A1**

(12)

**EUROPEAN PATENT APPLICATION**

(43) Date of publication:  
**25.02.2009 Bulletin 2009/09**

(51) Int Cl.:  
**F41A 15/06<sup>(2006.01)</sup>**

(21) Application number: **08104845.6**

(22) Date of filing: **23.07.2008**

(84) Designated Contracting States:  
**AT BE BG CH CY CZ DE DK EE ES FI FR GB GR  
 HR HU IE IS IT LI LT LU LV MC MT NL NO PL PT  
 RO SE SI SK TR**  
 Designated Extension States:  
**AL BA MK RS**

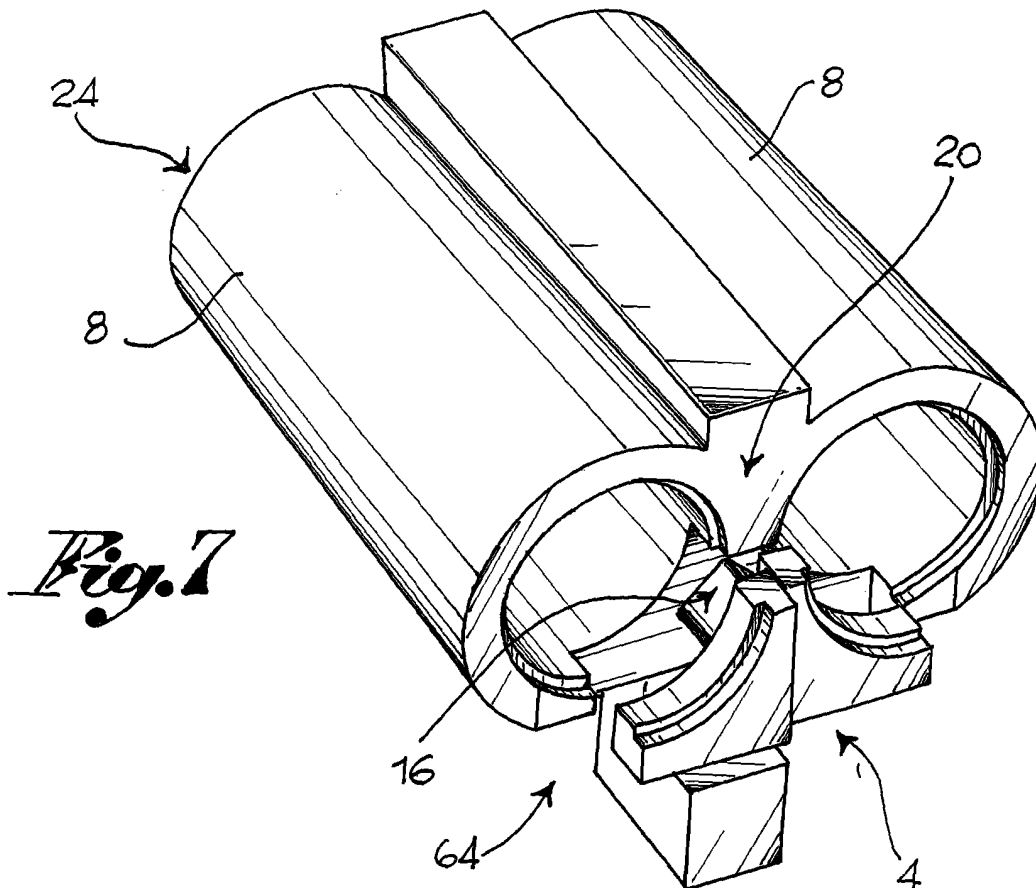
(71) Applicant: **Fausti Stefano S.r.l.  
 25060 Marcheno (BS) (IT)**  
 (72) Inventor: **Belleri, Giordano  
 I-25063, Gardone Val Trompia, BRESCIA (IT)**  
 (74) Representative: **Pulieri, Gianluca Antonio  
 Jacobacci & Partners S.p.A.  
 Piazza dela Vittoria, 11  
 25122 Brescia (IT)**

(30) Priority: **27.07.2007 IT BS20070110**

(54) **Anti-rotation extractor for shotgun, and related shotgun**

(57) An anti-rotation extractor (4) for shotgun (24), in particular for a break-action shotgun, suitable for ejecting the cartridge case when the break-action is opened. The

extractor (4) is guided by a housing (16) on the breech (20) of the shotgun with which it creates a prismatic type coupling in such a way as to ensure functioning without jamming.



**EP 2 028 433 A1**

## Description

**[0001]** This invention concerns an extractor for shotguns, in particular break-action shotguns, and a related shotgun.

**[0002]** Extractors have the function of ejecting the cartridge case from the chamber, in particular after the cartridge has been fired.

**[0003]** Extractors of a well known type consist of a head, set in the receiver, which accommodates an arc of the cartridge base, and a receiver shank guided in a special housing.

**[0004]** The head creates a coupling of form with the cartridge base which may have a groove or collar to facilitate grasping and extraction of the cartridge case.

**[0005]** On opening the break action a lever mechanism engages with the extractor shank and at least partially extracts the cartridge case from the barrels, thus favouring automatic ejection of the cartridge case.

**[0006]** State of the art extractors consist of a cylindrical shank set in a cylindrical housing of the breech and a pin connected to the head, in an offset position with regard to the shank and the cylindrical housing, in such a way as to engage in a corresponding hole in the breech.

**[0007]** the shank has the function of guiding the translation motion of the extractor along an axial direction and the pin has the function of preventing rotation of the extractor with regard to the said axial direction.

**[0008]** In fact it is of fundamental importance that the extractor should not rotate with regard to the housing, this in order to avoid the head jamming on the cartridge case base and preventing extraction from the barrels.

**[0009]** There are numerous disadvantages in state of the art solutions. In fact the pins, due to dimensional tolerances or clearances, are not perfectly aligned with the related coupling hole.

**[0010]** Consequently state of the art extractors often tend to jam. The phenomenon is further increased by heat deformations of the extractor generated by heating of the shotgun after numerous rounds have been fired.

**[0011]** The subject-matter of this invention is an extractor and related shotgun intended to eliminate the drawbacks mentioned above in connection with current technique.

**[0012]** These drawbacks and limitations are resolved by an extractor in accordance with claim 1 and by a shotgun in accordance with claim 13.

**[0013]** Other forms of making the extractor and shotgun in accordance with the invention are described in the subsequent claims.

**[0014]** Further characteristics and advantages of this invention will be more clearly understandable from the following description of the most preferable though not limitative examples of its manufacture, in which:

**[0015]** figure 1 shows a perspective view of an extractor in accordance with a form of this invention;

**[0016]** figure 2 shows a perspective view of the extractor in figure 1 with a different angulation;

**[0017]** figure 3 shows a plan view of the extractor in figure 1, from the side of arrow III in figure 1;

**[0018]** figure 4 shows a side view of the extractor in figure 1, from the side of arrow IV in figure 1;

5 **[0019]** figures 5a-5f show sectional views of the extractor along the plane of section V-V in figure 3, in accordance with possible variants in the implementation of this invention.

10 **[0020]** figure 6 shows a perspective view of a shotgun component suitable for housing an extractor in accordance with this invention;

**[0021]** figure 7 shows a perspective view of a shotgun component fitted with an extractor in accordance with this invention.

15 **[0022]** The elements or parts thereof shared by the forms of creation described below will be indicated by the same numerical references.

**[0023]** With reference to the above figures, 4 globally indicates an extractor for shotguns suitable for ejecting a cartridge case from shotgun 8.

20 **[0024]** Extractor 4 consists of a shank 12 such as to run axially along axial direction X-X within housing 16 set in breech 20 of shotgun 24.

25 **[0025]** The extractor moreover consists of head 28, associable with said breech 20 in such a way as to intercept a part of a cartridge case base and bring about ejection of the cartridge case from barrel 8. Preferably the head includes a hook-up part 32 suitable for engaging the base of a cartridge. For example, hook-up part 32 may include a tapering portion extending for an arc of a circle in such a way as to be inserted into the groove of a cartridge base. Hook-up part 32 may also include a collar extending for an arc of a circle in such a way as to engage the lip of a cartridge base.

30 **[0026]** Most favourably, at least one portion of restraint 40 of the shank has a transversal section, with regard to a plane of section perpendicular to said axial direction X-X, equipped with at least one projection 45 with regard to the maximum imaginary circle 46 containable in the said section, in such a way as to achieve a prismatic type coupling with regard to housing 16 of shotgun 24, at least partially counterprofiled with regard to the said portion of restraint 40 of shank 12 (figures 5a-5e).

35 **[0027]** In other words, at least one portion of restraint 40 of shank 12 has a transversal section, with regard to a plane of section perpendicular to said axial direction X-X, with non-circular geometry in such a way as to achieve, with housing 16 of shotgun 24, at least partially counterprofiled with regard to the said portion of restraint 40 of shank 12, a prismatic type coupling.

40 **[0028]** In yet other words, the geometry of shank 12, in correspondence to portion of restraint 40, is non-circular in such a way that after coupling with housing 16 of breech 20 it allows an axial translation of the extractor with regard to housing 16 but prevents any rotation of shank 12 and therefore of extractor 4 with regard to housing 16. So hook-up part 32 may vary its axial position with regard to housing 16, following activation of extractor

4, but cannot rotate with regard to housing 16 and therefore with regard to the base of the cartridge case in the shotgun barrel.

**[0029]** The portion of restraint extends in such a way as to achieve prismatic coupling with housing 16 even in a configuration of maximum protrusion of the extractor from the housing itself. In other words, even in extracted configuration the portion of restraint 40 is coupled with the housing in such a way as to constitute a prismatic guide for the extractor.

**[0030]** In accordance with a possible form of implementation the portion of restraint of the shank has a transversal section that is triangular, quadrangular, for example square or rectangular, elliptical or hexagonal.

**[0031]** In accordance with another form of implementation (figure 5c), portion of restraint 40 of the shank has a transversal section at least partially circular and equipped, in correspondence to a part of circular side wall 47, with at least one ribbing 48 suitable for preventing rotation of the shank with regard to the housing.

**[0032]** It is also possible to create (figure 5d) a portion of restraint 40 of the shank with a transversal section at least partially circular and equipped, in correspondence to a part of circular side wall 47, with at least one groove 49 suitable for preventing rotation of shank 12 with regard to a counterprofiled housing.

**[0033]** Preferably the transversal section of shank 12 is substantially constant along its axial extent from engagement extremity 50 of shank 12 in housing 16 to head 28 of extractor 4.

**[0034]** Another possibility is a shank 12 with a transversal section at least partially tapered, running from head 28 to an engagement extremity 50 of the extractor in housing 16. This configuration favours the insertion of shank 12 in housing 16.

**[0035]** Shank 12 has at least one recess 60 suitable for engagement with an action mechanism 64 of shotgun 24, suitable for extracting extractor 4 from its housing 16.

**[0036]** Extractor 4 may be subdivided into two parts 4', 4", symmetrical with regard to a symmetry plane parallel to the said axial direction X-X, each part of the extractor 4', 4" being suitable for interfacing with cartridges in side by side or over-and-under shotgun barrels. The two parts 4', 4" are mechanically separate in such a way as to be activated by action mechanism 64 independently. In this way it is possible, on opening the break action, to remove only the fired cartridge case.

**[0037]** A shotgun 24 in accordance with this invention preferably has, in breech 20, a housing 16 for extractor 4, the said housing being at least partially counterprofiled with regard to portion of restraint 40 of shank 12 of extractor 4. In this way, in one mounting configuration of extractor 4, the shank creates with the shotgun housing a coupling of form suitable to permit translation of shank 12 with regard to the housing along axial direction X-X and to prevent rotation of the shank with regard to the housing in terms of axial direction X-X.

**[0038]** In other words, shotgun 24 consists of a breech

20 with a housing 16 for the extractor that is at least partially counterprofiled with regard to portion of restraint 40 of the extractor shank in such a way as to create, in a mounting configuration of extractor 4, a prismatic coupling of shank 12 and housing 16 suitable for permitting solely the translation of the extractor in housing 16 and preventing rotation of the extractor with regard to housing 16.

**[0039]** The shotgun housing may therefore have a transversal section that is triangular or quadrangular, for example square or rectangular, elliptical, hexagonal, trapezoidal or, for example, swallow-tail.

**[0040]** In accordance with further embodiments, the extractor housing has a transversal section at least partially circular and equipped, in correspondence to a circular portion of lateral wall, with at least one ribbing suitable for engagement with groove 49 of shank 12 of extractor 4, in such a way as to prevent rotation of extractor 4 in housing 16.

**[0041]** In accordance with a further embodiment, the extractor housing has a transversal section at least partially circular equipped, in correspondence to a circular portion of lateral wall, with at least one groove suitable for receiving ribbing 48 of shank 12 of extractor 4, in such a way as to prevent rotation of extractor 4 in housing 16.

**[0042]** The housing of shotgun 24 may have a transversal section substantially constant along its axial extension from an extremity of engagement for the extractor to an extremity of arrest of the extractor. There is moreover the possibility of creating a housing 16 with a transversal section at least partially tapered, moving from an extremity of engagement for the extractor to an extremity of arrest of the extractor.

**[0043]** Preferably the shotgun consists of double barrels 8, side by side or over-and-under, and an extractor 4 subdivided into two parts 4', 4", mechanically distinct and symmetrical with regard to a symmetry plane parallel to the said axial direction, each part 4', 4" of extractor 4 being suitable for interfacing with cartridges contained in the said barrels.

**[0044]** The shotgun moreover consists of action mechanism 64, for example of a well known type, suitable for engagement with extractors 4 in such a way as to activate their extraction. The shotgun is preferably of the break-action kind and the action mechanism is actuated by the movement of opening the break action. In other words, on opening the break action the extractors extract the cartridge cases from the barrels.

**[0045]** Most favourably, the creation of housing 16 in breech 20 sets out from a full section of breech 20, working it with an electro-erosion head. Preferably the electro-erosion head is counterprofiled with regard to the housing in such a way as to obtain the housing in the breech in negative. In other words the electro-erosion head has the form of the shank of the associable extractor. It is also possible to create a housing 16 which is initially cylindrical, for example by drilling a dead hole and subsequently working the housing with an electro-erosion head

in such a way as to obtain a non-circular geometry.

**[0046]** In other words a dead hole may be drilled with a diameter equal to the diameter of the maximum imaginary circle 46 containable in the said housing section and the latter be subsequently modified in such a way as to render it non-circular and suitable for creating a prismatic guide for the extractor.

**[0047]** The advantage of first drilling a dead hole lies in limiting the portion of material to be eroded by the electro-erosion head, thus reducing the time and costs of electro-erosion.

**[0048]** As may be appreciated from the preceding descriptions, the extractor and the shotgun in accordance with the invention overcome the drawbacks involved in the current technique.

**[0049]** In particular, all rotation of the extractor is prevented, both when it is fully lodged in the housing and when it is fully extracted from the breech.

**[0050]** This ensures that the extractor is always guided axially in its housing, without rotating with regard to the latter and therefore without jamming.

**[0051]** Unusually, the extractor creates a prismatic guide with the housing of the breech. In other words the housing has the function not only of guiding the axial translation movement of the shank but also of preventing any rotation with regard to the housing. In yet other words, the extractor shank has both the function of extractor axial guide and anti-rotation device.

**[0052]** With view to meeting contingent and specific requirements a specialised technician could carry out numerous modifications and variations on the extractors and shotguns described above, all remaining within the context of the invention as defined in the following claims.

## Claims

1. Extractor (4) for shotgun, suitable for expelling a cartridge case from a shotgun barrel (8), comprising
  - a shank (12) running axially along axial direction (X-X) within a housing (16) on the breech (20) of the shotgun
  - and a head (28) associable with said breech (20) in such a way as to intercept part of the base of a cartridge case and extract it from the barrel (8),

distinguished by the fact that

at least one portion of restraint (40) of the shank (12) has a transversal section with regard to a plane of section perpendicular to said axial direction (X-X), equipped with at least one projection (45) with regard to the maximum imaginary circle (46) containable in the said section, in such a way as to achieve a prismatic type coupling with the said housing (16) of the shotgun, counterprofiled with regard to the said portion of restraint (40) of the shank (12).

2. Extractor (4) for shotgun in accordance with claim 1, in which at least one portion of restraint (40) of the shank (12) has a transversal section, with regard to a plane of section perpendicular to said axial direction (X-X), with non-circular geometry in such a way as to achieve, with the housing (16) of the shotgun (24), at least partially counterprofiled with regard to the said portion of restraint (40) of the shank (12), a prismatic type coupling.
3. Extractor (4) for shotgun in accordance with claim 1 or 2, in which the portion of restraint (40) extends in such a way as to create a prismatic coupling with the housing (16) also in a configuration of maximum protrusion of the extractor from the housing (16) itself.
4. Extractor (4) per shotgun in accordance with claim 1, 2 or 3 in which the said portion of restraint of the shank has a triangular transverse section.
5. Extractor (4) in accordance with claim 1, 2 or 3 in which the said portion of restraint (40) of the shank (12) has a quadrangular transverse section.
6. Extractor (4) in accordance with claim 1, 2 or 3 in which the said portion of restraint (40) of the shank (12) has an elliptical transverse section.
7. Extractor (4) in accordance with claim 1, 2 or 3 in which the said portion of restraint (40) of the shank (12) has an at least partially circular transverse section equipped, in correspondence to a part of the circular side wall (47), with at least one ribbing (48) suitable for preventing rotation of the shank (12) with regard to a housing (16) counterprofiled thereto.
8. Extractor (4) in accordance with claim 1, 2 or 3, in which the said portion of restraint (40) of the shank (12) has an at least partially circular transverse section equipped, in correspondence to a part of the circular side wall (47), with at least one groove (49) suitable for preventing rotation of the shank (12) with regard to a housing (16) counterprofiled thereto.
9. Extractor (4) in accordance with any of the preceding claims from 1 to 8 in which the said shank (12) has an at least partially tapered transversal section, moving from the head (28) towards an engagement extremity (50) in the housing (16).
10. Extractor (4) in accordance with any of the preceding claims in which the said shank (12) has at least one recess (60) suitable for engagement with an action mechanism (64) of the associable shotgun for extracting the extractor (4) from its housing (16).
11. Extractor (4) in accordance with any of the preceding claims in which the said head (28) includes a hook-

up portion (32) at least partially counterprofiled with the base of a cartridge.

12. Extractor (4) in accordance with any of the preceding claims in which the said extractor (4) is subdivided into two parts (4',4"), symmetrical with regard to a symmetry plane parallel to the said axial direction (X-X), each part (4',4") of the extractor being suitable for interfacing with cartridges in side by side or over-and-under shotgun barrels.

13. Shotgun (24) including at least one extractor (4) in accordance with any of the preceding claims from 1 to 12, the shotgun comprising a breech (20) with a housing (16) for extractor, at least partially counterprofiled with regard to the said portion of restraint (40) of shank (12) of the extractor (4) in such a way that in a configuration of mounting the extractor (4), the shank (12) creates with the housing (16) of the shotgun a coupling suitable to permit translation of the shank (12) with regard to housing (16) along axial direction (X-X) and to prevent rotation of the shank (12) with regard to housing (16) along axial direction (X-X).

14. Shotgun (4) in accordance with claim 13, comprising a breech (20) with an extractor housing (16) at least partially counterprofiled with regard to the said portion of restraint (40) of the shank (12) of the extractor (4) in such a way that, in a configuration of mounting the extractor (4), a prismatic coupling is created between the shank (12) and the housing (16) suitable for permitting solely the translation of the extractor (4) in the housing (16) and preventing rotation of the extractor (4) with regard to the housing (16).

15. Shotgun (4) in accordance with any of the preceding claims from 13 to 14, comprising double barrels (8), side by side or over-and-under, and an extractor (4) subdivided into two parts (4',4"), mechanically distinct and symmetrical with regard to a symmetry plane parallel to the said axial direction, each part (4',4") of the extractor (4) being suitable for interfacing with cartridges contained in the said barrels.

5

10

15

20

25

30

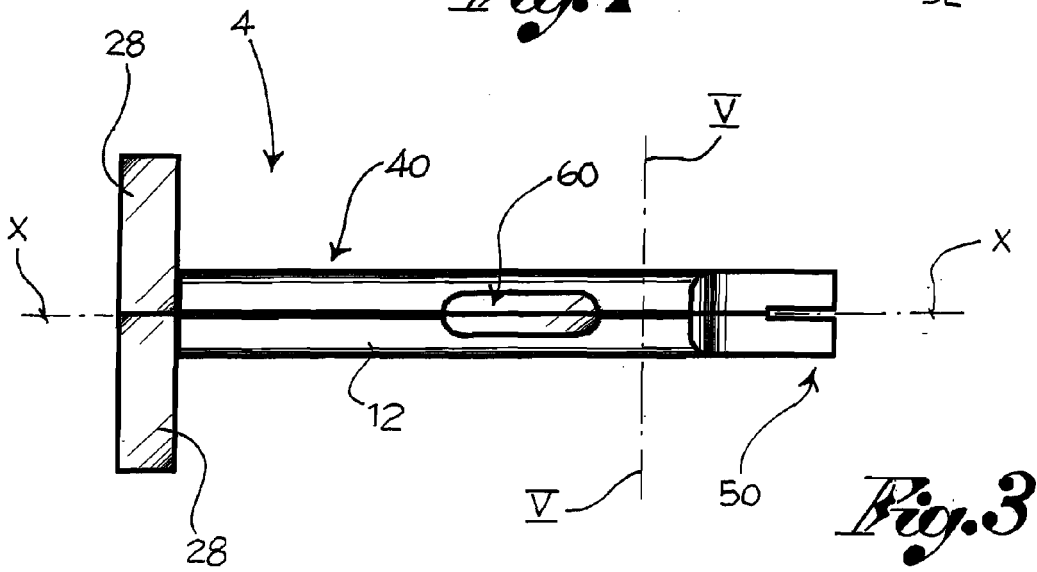
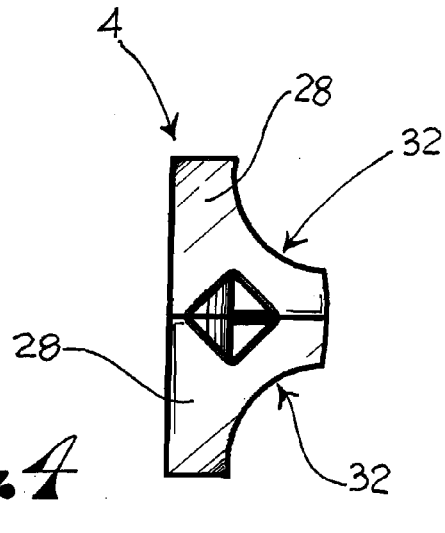
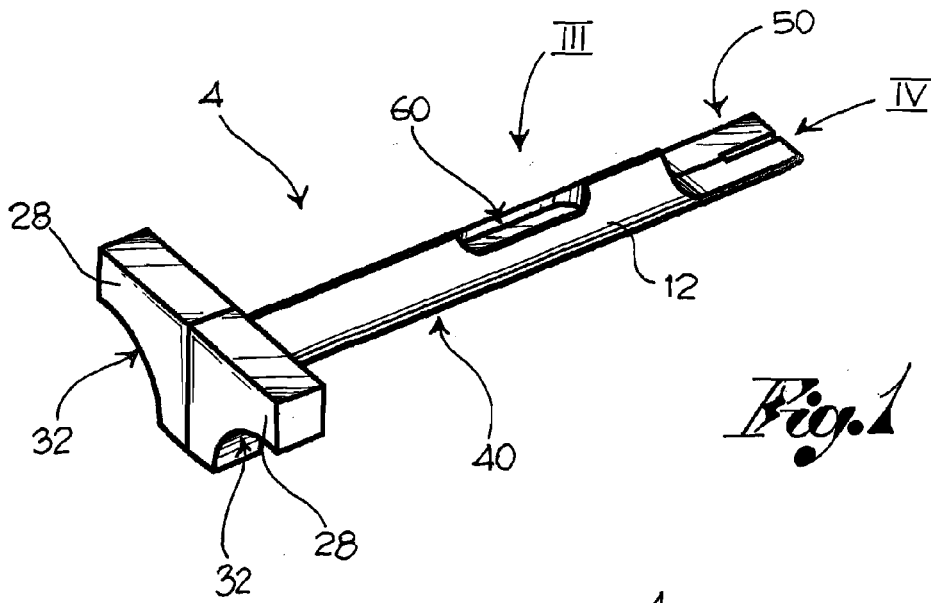
35

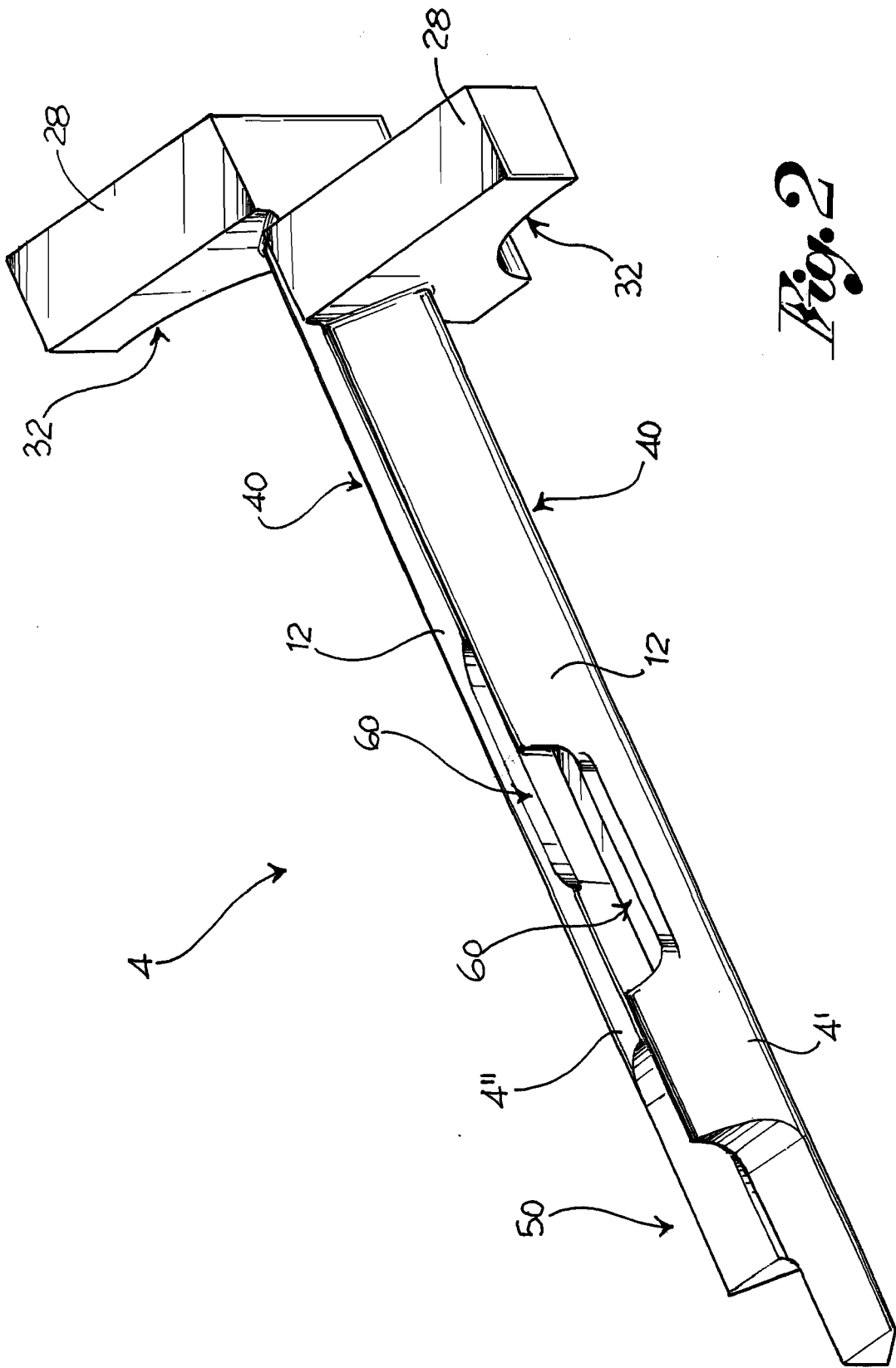
40

45

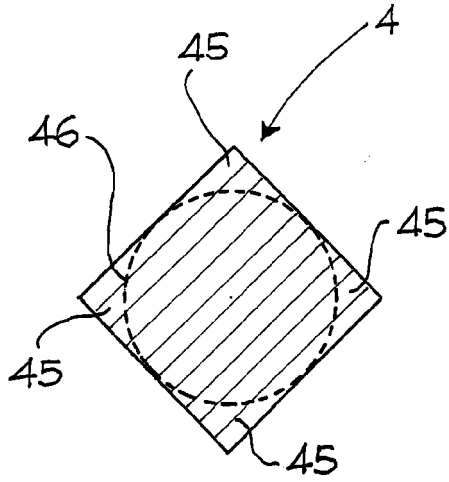
50

55

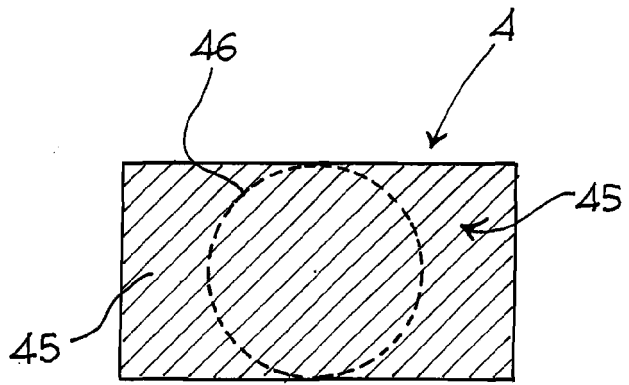




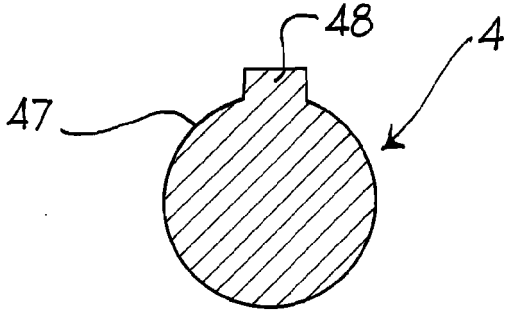
*Fig. 2*



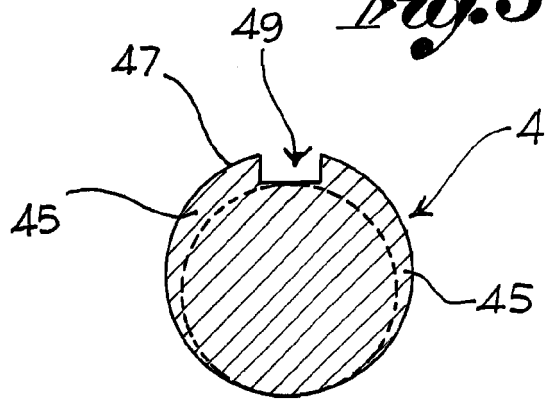
*Fig. 5a*



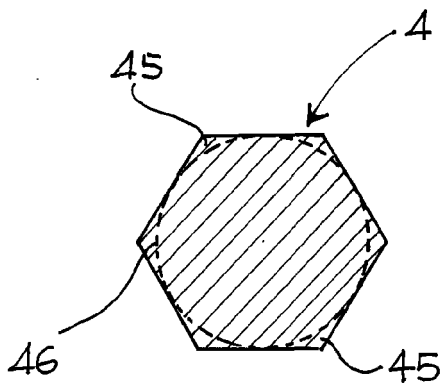
*Fig. 5b*



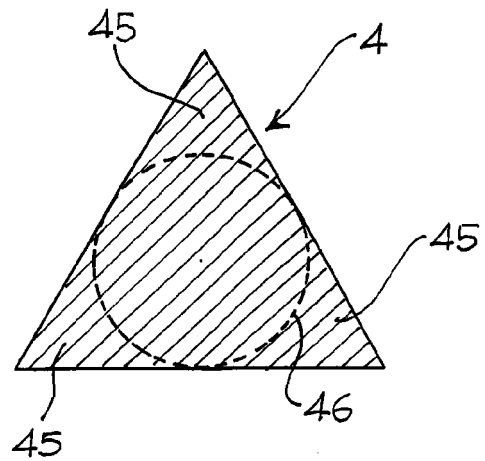
*Fig. 5c*



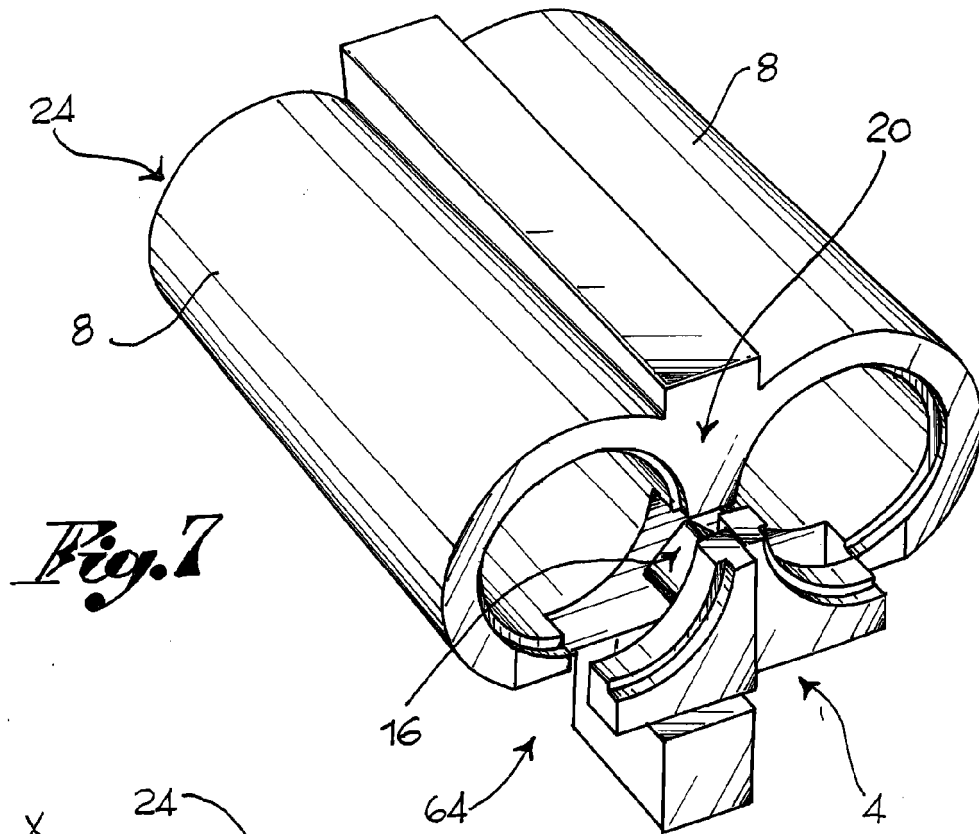
*Fig. 5d*



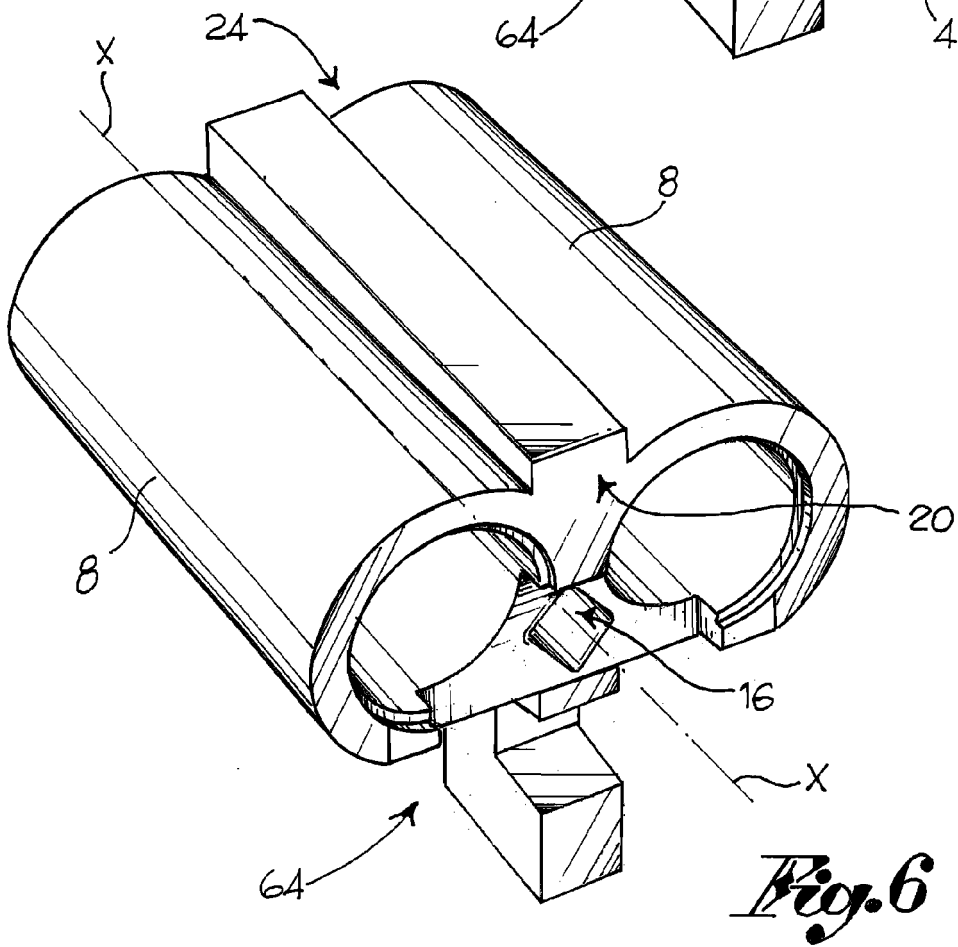
*Fig. 5e*



*Fig. 5f*



*Fig. 7*



*Fig. 6*



## EUROPEAN SEARCH REPORT

Application Number  
EP 08 10 4845

DOCUMENTS CONSIDERED TO BE RELEVANT			
Category	Citation of document with indication, where appropriate, of relevant passages	Relevant to claim	CLASSIFICATION OF THE APPLICATION (IPC)
X	US 2 952 933 A (STEVENS BRUCE W) 20 September 1960 (1960-09-20) * figures 1,3,4 * * column 2, line 24 - column 3, line 52 * -----	1-6, 11-15	INV. F41A15/06
X	US 5 018 293 A (MAINLAND DONALD R [US]) 28 May 1991 (1991-05-28) * abstract; figures 4,6,8 * * column 4, line 66 - column 6, line 11 * -----	1-6,9, 10,12-15	
X	BE 354 877 A (NICOLAS LAJOT) 1928  * figure * * page 2, line 14 - line 22 * * page 3, line 7 - line 10 * -----	1-6, 11-15	
X	FR 1 111 992 A (PEYRONNET ÉMILE) 7 March 1956 (1956-03-07) * figures 6-8 * * page 1, right-hand column, paragraph 2 - paragraph 3 * -----	1-3,7,8, 11,13,14	
X	US 2005/262749 A1 (ROUSSEAU JOSEPH F N [US] ET AL) 1 December 2005 (2005-12-01) * figures 6,8-14 * * paragraph [0073] - paragraph [0074] * -----	1-3, 10-15	
The present search report has been drawn up for all claims			
Place of search The Hague		Date of completion of the search 21 November 2008	Examiner Schwingel, Dirk
CATEGORY OF CITED DOCUMENTS X : particularly relevant if taken alone Y : particularly relevant if combined with another document of the same category A : technological background O : non-written disclosure P : intermediate document		T : theory or principle underlying the invention E : earlier patent document, but published on, or after the filing date D : document cited in the application L : document cited for other reasons ----- & : member of the same patent family, corresponding document	

2

EPO FORM 1503 03.82 (P04C01)

**ANNEX TO THE EUROPEAN SEARCH REPORT  
ON EUROPEAN PATENT APPLICATION NO.**

EP 08 10 4845

This annex lists the patent family members relating to the patent documents cited in the above-mentioned European search report. The members are as contained in the European Patent Office EDP file on The European Patent Office is in no way liable for these particulars which are merely given for the purpose of information.

21-11-2008

Patent document cited in search report	Publication date	Patent family member(s)	Publication date
US 2952933	A	20-09-1960	NONE
US 5018293	A	28-05-1991	NONE
BE 354877	A		NONE
FR 1111992	A	07-03-1956	NONE
US 2005262749	A1	01-12-2005	AT 403128 T 15-08-2008 EP 1447638 A1 18-08-2004 US 2004103575 A1 03-06-2004

EPO FORM P0459

For more details about this annex : see Official Journal of the European Patent Office, No. 12/82