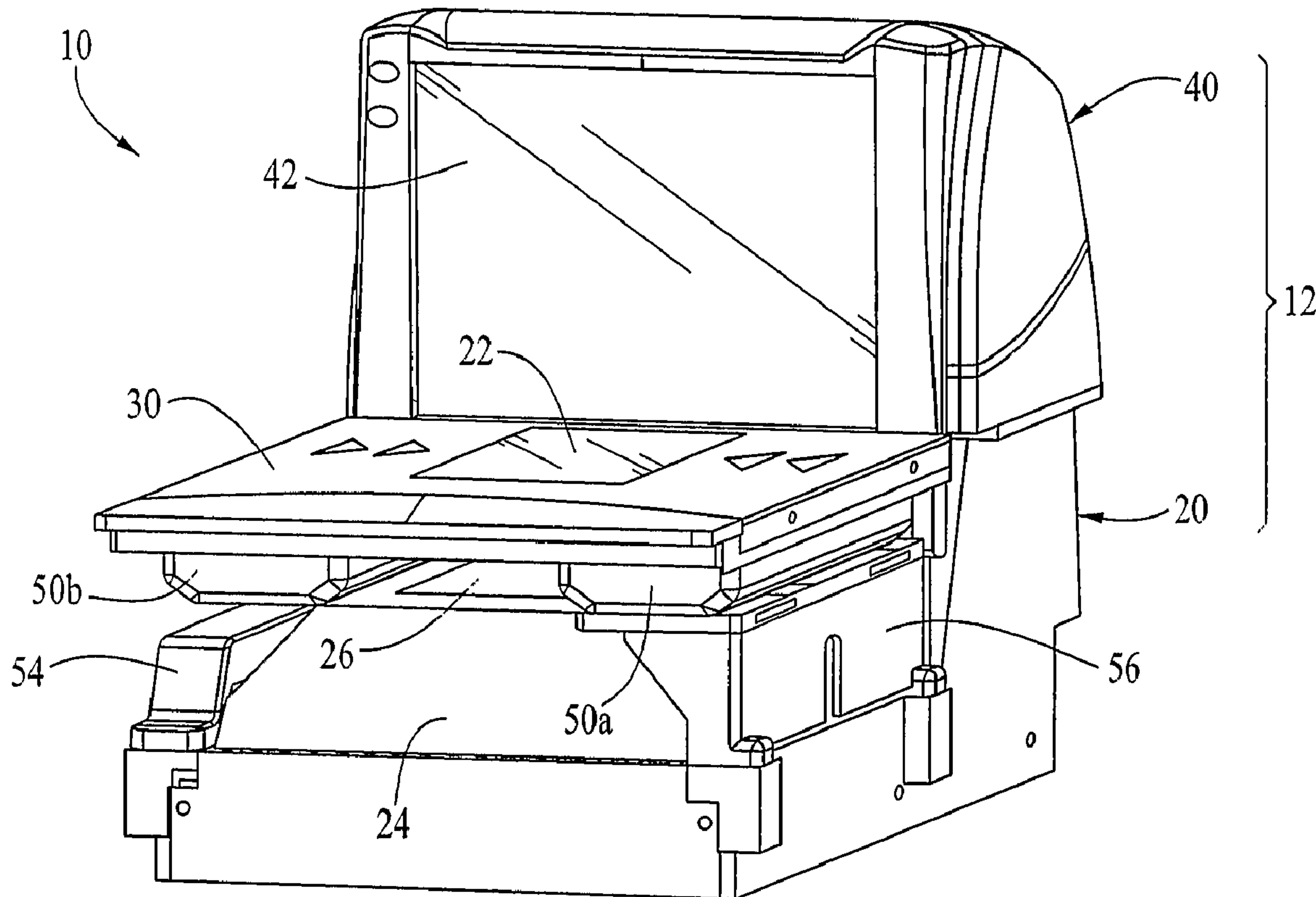




(86) Date de dépôt PCT/PCT Filing Date: 2003/01/31  
 (87) Date publication PCT/PCT Publication Date: 2003/08/07  
 (45) Date de délivrance/Issue Date: 2013/05/28  
 (85) Entrée phase nationale/National Entry: 2005/01/10  
 (86) N° demande PCT/PCT Application No.: US 2003/003041  
 (87) N° publication PCT/PCT Publication No.: 2003/065323  
 (30) Priorité/Priority: 2002/02/01 (US10/062,274)

(51) Cl.Int./Int.Cl. *G08B 13/14* (2006.01),  
*G07G 1/00* (2006.01), *G08B 13/24* (2006.01)  
 (72) Inventeurs/Inventors:  
 ACOSTA, JORGE L., US;  
 SVETAL, MICHAEL P., US;  
 SALIM, MOHAMED A., US;  
 RUDEEN, ROBERT W., US;  
 BONTLY, CRAIG H., US;  
 HOSKINSON, JEFFREY J., US  
 (73) Propriétaires/Owners:  
 SENSORMATIC ELECTRONICS, LLC, US;  
 DATALOGIC ADC, INC., US  
 (74) Agent: SMART & BIGGAR

(54) Titre : LECTEUR DE DONNEES ET SYSTEME ELECTRONIQUE DE SURVEILLANCE D'ARTICLES COMBINES  
 (54) Title: COMBINED DATA READER AND ELECTRONIC ARTICLE SURVEILLANCE (EAS) SYSTEM



(57) Abrégé/Abstract:

An integrated data reader and electronic article surveillance (EAS) system (10), and methods of operation. In one configuration, a data reader such as a bar code scanner is equipped with an EAS deactivation module disposed behind the scanner surface



(57) **Abrégé(suite)/Abstract(continued):**

preferably downstream and/or upstream of the scanner window (22, 42). The system (10) may be configured such that the EAS deactivation module is interchangeable from the right side of the scanner housing (which is preferred for left-to-right scanning motion) to the left side of the scanner housing (which is preferred for a right-to-left scanning motion). In other configurations, the deactivation module may be disposed in the housing adjacent to the window and oriented longitudinally and parallel to the sweep direction of the item. The EAS deactivation modules (350a, 350b) have various configurations such as simple planar coils, a magnetically active core with coil windings, or two parts L-shape construction.

(12) INTERNATIONAL APPLICATION PUBLISHED UNDER THE PATENT COOPERATION TREATY (PCT)

(19) World Intellectual Property  
Organization  
International Bureau



(43) International Publication Date  
7 August 2003 (07.08.2003)

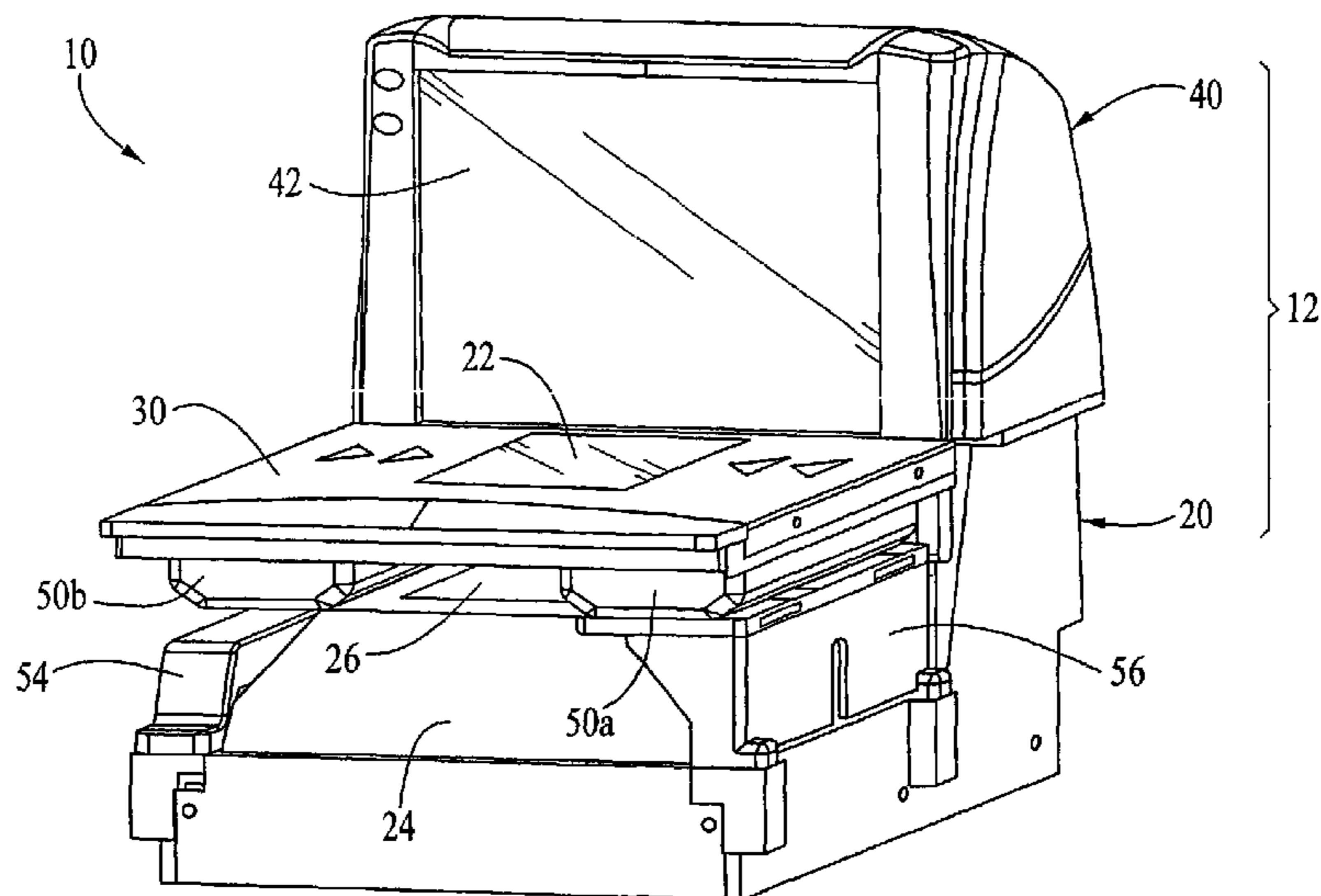
PCT

(10) International Publication Number  
**WO 2003/065323 A3**

- (51) International Patent Classification<sup>7</sup>: **G08B 13/14**
- (21) International Application Number: PCT/US2003/003041
- (22) International Filing Date: 31 January 2003 (31.01.2003)
- (25) Filing Language: English
- (26) Publication Language: English
- (30) Priority Data:  
60/353,139 1 February 2002 (01.02.2002) US
- (71) Applicants: **PSC SCANNING, INC.** [US/US]; 959 Terry Street, Eugene, OR 97402 (US). **SENSORMATIC ELECTRONICS CORPORATION** [US/US]; 6600 Congress Avenue, Boca Raton, FL 33487 (US).
- (71) Applicants and  
(72) Inventors: **ACOSTA, Jorge, L.** [US/US]; 4075 Aerial Way, #202, Eugene, OR 97402 (US). **SVETAL, Michael, P.** [US/US]; 4075 Aerial Way, #135, Eugene, OR 97102 (US). **SALIM, Mohamed, A.** [SO/US]; 1626 Oak Patch Rd., Eugene, OR 97402 (US). **RUDEEN, Robert, W.** [US/US]; 2345 Oakway Terrace, Eugene, OR 97401 (US). **BONTLY, Craig, H.** [US/US]; 2892 West 18th St., Eugene, OR 97402 (US). **HOSKINSON, Jeffrey, J.** [US/US]; 3091 Shirley St., Eugene, OR 97404 (US).
- (74) Agents: **RAFTER, John, A., Jr.** et al.; Stoel Rives LLP, 900 SW Fifth Avenue, Suite 2600, Portland, OR 97204-1268 (US).
- (81) Designated States (*national*): AE, AG, AL, AM, AT, AU, AZ, BA, BB, BG, BR, BY, BZ, CA, CH, CN, CO, CR, CU, CZ, DE, DK, DM, DZ, EC, EE, ES, FI, GB, GD, GE, GH, GM, HR, HU, ID, IL, IN, IS, JP, KE, KG, KP, KR, KZ, LC, LK, LR, LS, LT, LU, LV, MA, MD, MG, MK, MN, MW, MX, MZ, NO, NZ, OM, PH, PL, PT, RO, RU, SC, SD, SE, SG, SK, SL, TJ, TM, TN, TR, TT, TZ, UA, UG, UZ, VC, VN, YU, ZA, ZM, ZW.

[Continued on next page]

(54) Title: COMBINED DATA READER AND ELECTRONIC ARTICLE SURVEILLANCE (EAS) SYSTEM



(57) Abstract: An integrated data reader and electronic article surveillance (EAS) system (10), and methods of operation. In one configuration, a data reader such as a bar code scanner is equipped with an EAS deactivation module disposed behind the scanner surface preferably downstream and/or upstream of the scanner window (22, 42). The system (10) may be configured such that the EAS deactivation module is interchangeable from the right side of the scanner housing (which is preferred for left-to-right scanning motion) to the left side of the scanner housing (which is preferred for a right-to-left scanning motion). In other configurations, the deactivation module may be disposed in the housing adjacent to the window and oriented longitudinally and parallel to the sweep direction of the item. The EAS deactivation modules (350a, 350b) have various configurations such as simple planar coils, a magnetically active core with coil windings, or two parts L-shape construction.

WO 2003/065323 A3

**WO 2003/065323 A3**

**(84) Designated States (regional):** ARIPO patent (GH, GM, KE, LS, MW, MZ, SD, SL, SZ, TZ, UG, ZM, ZW), Eurasian patent (AM, AZ, BY, KG, KZ, MD, RU, TJ, TM), European patent (AT, BE, BG, CH, CY, CZ, DE, DK, EE, ES, FI, FR, GB, GR, HU, IE, IT, LU, MC, NL, PT, SE, SI, SK, TR), OAPI patent (BF, BJ, CF, CG, CI, CM, GA, GN, GQ, GW, ML, MR, NE, SN, TD, TG).

— *with amended claims*

**(88) Date of publication of the international search report:**  
11 December 2003

**Date of publication of the amended claims:** 22 January 2004

**Published:**

— *with international search report*

*For two-letter codes and other abbreviations, refer to the "Guidance Notes on Codes and Abbreviations" appearing at the beginning of each regular issue of the PCT Gazette.*

## COMBINED DATA READER AND ELECTRONIC ARTICLE SURVEILLANCE (EAS) SYSTEM

### Background of the Invention

**[0001]** The field of the present invention relates to data reading systems and electronic article security (EAS) systems. In particular, a method and apparatus are described herein for integrating a data reading system such as a bar code scanner with an EAS system.

**[0002]** In both retail checkout and inventory control environments, items are typically provided with readable tags or labels such as bar codes or RFID tags. Data reading devices such as barcode scanners and RFID readers are provided at the checkout station to read the codes or tags and obtain the data contained therein. The data may be used to identify the article, its price, and other characteristics or information related to checkout or inventory control. These data readers automate the information retrieval to facilitate and speed the checkout process. Thus data readers such as bar code scanners are pervasive at retail checkout.

**[0003]** Scanners generally come in three types: (a) handheld, such as the PowerScan™ scanner, (b) fixed and installed in the countertop such as the Magellan® scanner, or (c) a hybrid scanner such as the Duet® scanner usable in either a handheld or fixed mode. Each of these scanners is manufactured by PSC Inc. of Eugene, Oregon. In a typical operation, retail clerk uses either a handheld scanner to read the barcode symbols on the articles one at a time or passes the articles through the scan field of the fixed scanner one at a time. The clerk then places the articles into a shopping bag or other suitable container.

**[0004]** Though bar codes provide for rapid and accurate item identification at checkout, the bar codes do not provide for item security against theft. Electronic article surveillance (EAS) systems have employed either reusable EAS tags or disposable EAS tags to monitor articles to prevent shoplifting and unauthorized

removal of articles from store. Reusable EAS tags are normally removed from the articles before the customer exits the store. Disposable EAS tags are generally attached to the packaging by adhesive or are disposed inside item packaging. These tags remain with the articles and must be deactivated before they are removed from the store by the customer. Deactivation devices use coils which are energized to generate a magnetic field of sufficient magnitude to render the EAS tag inactive. Once deactivated, the tags are no longer responsive to the incident energy of the EAS system so that an alarm is not triggered.

**[0005]** In one type of deactivation system the checkout clerk passes the articles one at a time over a deactivation device to deactivate the tags and then places the articles into a shopping bag or other container. This system employs a deactivation coil (or coils) in a separate housing disposed horizontally within the counter typically downstream of the fixed scanner. The clerk moves the tagged articles through the scan volume scanning the bar code and then subsequently moves the item across the horizontal top surface of the deactivation coil housing such that the tag is disposed generally coplanar with the coil.

**[0006]** Some retail establishments having high volumes find it desirable to expedite and facilitate the checkout process including the scanning of the bar code data and the deactivation of the EAS tags. In the typical point of sale (POS) location such as the checkout counter of a retail checkout station, counter space is limited. In one system, an EAS deactivation coil is disposed around the horizontal scan window of a two-window "L" shaped scanner such as the Magellan® scanners. In such a system, bar code scanning and EAS tag deactivation presumably are accomplished over the same scan volume. However, the present inventors have recognized that such a configuration may not best accommodate the expected motion of items through the checkout station.

#### Summary of the Invention

**[0007]** The present invention is directed to an integrated data reader and EAS system, and methods of operation. In a preferred configuration, a data reader such as a bar code scanner is equipped with one or more EAS deactivation modules disposed behind the scanner surface and arranged to generate a deactivation field of a desired orientation to deactivate EAS tags on items as they are passed through the scan field defined by the scanner window(s) of the bar code scanner.

71073-161

Some embodiments of the invention relate to a checkout system for data reading and electronic article security (EAS) deactivation, comprising a housing including a lower housing section containing a lower window oriented generally horizontally and an upper housing section containing an upper window oriented generally vertically; a data reader disposed in the housing to read an item through the upper and lower windows as the item is passed through a read volume defined between the upper and lower windows; an EAS deactivation unit disposed in the housing, wherein the deactivation unit comprises a magnetic coil unit including a central portion and outer windings disposed about the central portion, the magnetic coil unit generating a magnetic field for deactivating electronic security tags being located in at least a portion of the read volume.

Some embodiments of the invention relate to a method for checkout of an item bearing an optical code and having a deactivatable security tag, comprising the steps of: passing the item along an item path and through a read volume of a data reader, the data reader being disposed in a housing; reading the optical code on the item with the data reader through a window in the housing; generating a security tag deactivation field with a security tag deactivation unit, the deactivation unit comprising a magnetic coil unit formed of outer windings arranged about a central core disposed in the housing, the deactivation field being located in the item path and at least partially overlapping the read volume for deactivating electronic security tags being passed through the read volume.

Some embodiments of the invention relate to a checkout device comprising: a scale assembly including a base portion and a weigh plate over the base portion, wherein the weigh plate includes an aperture; a barcode reader between the base portion and the weigh plate, the barcode reader reading a barcode affixed to an item through the aperture in the weigh plate; and a security label deactivation system disposed between the base portion and the weigh plate which deactivates a security label affixed to the item after the barcode is read by the barcode reader, the security label deactivation system integrated within the scale

71073-161

assembly, wherein the security label deactivation system includes a magnetic coil assembly for sensing and deactivating the security label.

Some embodiments of the invention relate to a checkout device for reading optical codes on items being passed through a read volume, comprising an enclosure; a removable platter positioned over the enclosure and below the read  
5 volume, the platter including a platter window disposed therein; a data reader including a reader window disposed in the enclosure and below the platter window, the data reader reading an optical code on an item being passed through the read volume; a magnetic deactivation coil unit disposed between the platter and the data  
10 reader, the magnetic deactivation coil unit including a central portion and outer windings arranged about the central portion, the magnetic deactivation coil unit generating a magnetic field for deactivating an electronic article surveillance tag on the item being passed through the read volume.

Some embodiments of the invention relate to a checkout device  
15 comprising an optical code reader including an upper portion having a substantially vertical aperture and a lower portion having a substantially horizontal aperture; a platter suspended above the lower portion; and a security label deactivation system including a first magnetic coil unit disposed in the lower portion below the platter, the first magnetic coil assembly having a central portion with outer windings disposed  
20 about the central portion, the first magnetic deactivation coil unit generating a magnetic field for deactivating an electronic article surveillance tag, and a second magnetic coil unit disposed in the upper portion, the second magnetic coil unit having a central portion with outer windings disposed about the central portion, the second magnetic deactivation coil unit generating a magnetic field for deactivating an  
25 electronic article surveillance tag.

Some embodiments of the invention relate to a checkout device comprising: a scale assembly including a base portion and a weigh plate over the base portion, wherein the weigh plate includes an aperture; a barcode reader between the base portion and the weigh plate which reads a barcode through the



71073-161

aperture in the weigh plate; a security label deactivation system; and a controller that enables the security label deactivation system only after successful reading of the barcode, wherein the security label deactivation system comprises a magnetic coil unit disposed between the weigh plate and the base portion, the magnetic coil unit  
5 including outer windings disposed around a central core.

Some embodiments of the invention relate to a checkout device comprising: a barcode reader including a first portion having a substantially horizontal aperture and a second portion having a substantially vertical aperture; a weigh platter suspended above the first portion; and a security label deactivation  
10 system adjacent the first portion and under the weigh platter, wherein the security label deactivation system comprises a magnetic coil unit including a central portion and outer windings disposed about the central portion, the magnetic coil unit generating a magnetic field for deactivating electronic security tags.

Brief Description of the Drawings

[0008] Fig. 1 is a schematic diagram in a front perspective view of a combined data reader and EAS system according to a first embodiment of the present invention.

[0009] Fig. 2 is a front plan view of Fig. 1.

[0010] Fig. 3 is a left side plan view of Fig. 1.

[0011] Fig. 4 is a schematic diagram in a front perspective view of the system of Fig. 1 illustrated with the housing and weigh platter removed.

[0012] Fig. 5 is a front plan view of Fig. 4.

[0013] Fig. 6 is a left side plan view of Fig. 4.

[0014] Fig. 7 is a schematic diagram in a front right perspective view of a combined data reader and EAS system according to a second embodiment.

[0015] Fig. 8 is a front right left perspective view of the system of Fig. 7.

[0016] Fig. 9 is a schematic diagram in a front left perspective view of the system of Fig. 7 illustrated with the housing and weigh platter removed.

[0017] Fig. 10 is a schematic diagram in a front right perspective view of the system of Fig. 7 illustrated with the housing and weigh platter removed.

[0018] Fig. 11 is a schematic diagram in a front right perspective view of the system of Figs. 7-10, with the EAS coil unit inverted to the left side of the system.

[0019] Fig. 12 is a front left perspective view of the system of Fig. 11.

[0020] Fig. 13 is perspective view of a combined data reader and EAS system according to an alternate embodiment with deactivation unit(s) disposed in a vertical section of the reader.

[0021] Fig. 14 is perspective view of a combined data reader and EAS system according to an alternate embodiment, the data reader installed in a checkout counter and having multi-dimensional deactivation unit(s).

[0022] Fig. 15 is a left side plan view of Fig. 14.

[0023] Fig. 16 is perspective view of a combined data reader and EAS system according to an alternate embodiment with a deactivation unit disposed longitudinally between the horizontal and vertical sections of the reader.

[0024] Fig. 17 is a left side plan view of Fig. 16.

[0025] Fig. 18 is perspective view of a combined data reader and EAS system according to an alternate embodiment with a deactivation unit disposed longitudinally at the proximal end of the horizontal section distal from the vertical section.

71073-161

[0026] Fig. 19 is a left side plan view of Fig. 18.

[0027] Fig. 20 is perspective view of a combined data reader and EAS system according to an alternate embodiment with a deactivation unit disposed longitudinally at the upper end of the vertical section distal from the horizontal section.

[0028] Fig. 21 is a left side plan view of Fig. 20.

Detailed Description of Preferred Embodiments

[0029] Preferred embodiments of the present invention will now be described with reference to the drawings. To facilitate description, any reference numeral representing an element in one figure will represent the same element in any other figure.

[0030] Figs. 1-6 illustrate a combined data reader and EAS system 10 according to a first preferred embodiment. Referring primarily to Figs. 1-3, the system 10 includes an outer housing 12 with a lower housing section 20 containing a horizontal window 22 and an upper housing section 40 containing a vertical window 42. The lower housing section 20 includes a scale system supporting the weigh platter 30. The weigh platter 30 may comprise a single plane, or may comprise multiple planes as described in U.S. Patent No. 5,834,708 when the scanner-scale comprises a two-plane or vertical plane scanner. Though the system 10 is illustrated as a two-plane scanner with horizontal window 22 and vertical window 42, the system may alternately comprise a single window, either horizontal or vertical.

[0031] The system 10 includes one or two EAS coil units 50a, 50b each preferably encased in a plastic enclosure. The coil units 50a, 50b are each disposed between the weigh platter 30 and the bottom inner scan housing 24, but laterally outside the horizontal window 22 (that is, to the left or right as from the position of Figs. 1-2) so as to not interfere with the scan pattern being generated and projected out window 22.

[0032] Various components of the system 10, such as the enclosure 40/20 and even the platter 30, may be constructed of any suitable material, but are preferably constructed of a plastic or other suitable material that does not interfere with the magnetic fields produced by the coils.

[0033] Figs. 4-6 illustrate the system 10 with portions of the housing removed to better illustrate the internal components. The system 10 includes a first laser module and collector assembly 58a disposed on one side of the unit producing a first laser

beam directed onto one side of the polygon mirror 59 and a second laser beam and collector assembly 58b disposed on the other side of the unit from the first assembly 58a producing a first laser beam directed onto one side of the polygon mirror 59. The first and second reading beams are scanned by the polygon mirror 59 across pattern mirrors 53 in the lower housing section 20, usually reflecting off a first (primary) pattern mirror and then a second (secondary) mirror with some of the scan lines being formed by reflection off a third (tertiary) pattern mirror, and then all the scan lines being directed out through one of the windows 22, 42 projecting a complex scan pattern into the scan volume. Alternately, the only a single laser diode may be required generating a laser beam which is split by a beam splitter into a first and second reading beams, the first reading beam being directed onto the first side of the polygon mirror 59 and the second reading beam being directed onto the second side of the polygon mirror 59.

**[0034]** The system 10 of Figs. 1-3 is illustrated with two coil units 50a and 50b, but the system may be operative with one coil unit or two coil units. In a first configuration, the system 10 is provided with only one coil unit. Presuming that the scanner 10 is installed in a checkout counter with the flow of goods going from left-to-right (as viewed in Figs. 1-6), the coil unit 50a is disposed downstream of the scan volume. Items are passed left-to-right over the window 22 and through the scan volume where the scanner reads the optical code. Once the scanner has read the optical code on the item and identified it, in the same motion, the item is passed through the deactivation field of the coil unit 50a which is in communication with the scanner and deactivates the EAS tag on the item. Alternately, the system may be installed in a checkout counter with the flow of goods going from right-to-left (as viewed in Figs. 1-6), with the coil unit 50b disposed downstream of the scan volume. Items are passed right-to-left over the window 22 and through the scan volume where the scanner reads the optical code. Once the scanner has read the optical code on the item and identified it, in the same motion, the item is passed through the deactivation field of the coil unit 50b which is in communication with the scanner and deactivates the EAS tag on the item. In a single coil unit configuration, the other coil unit may be omitted yielding cost savings. In any of these configurations, the deactivation field and the scan volume may overlap.

**[0035]** In yet another embodiment, the system may comprise two coil units 50a, 50b. The coil units 50a and 50b comprise different functions. For example,

presuming that the scanner 10 is installed in a checkout counter with the flow of goods going from right-to-left (as viewed in Figs. 1-6), the coil unit 50a is disposed upstream of the scan volume and the coil unit 50b is disposed downstream of the scan volume. Items are passed right-to-left over the window 22 and through the scan volume where the scanner reads the optical code. The downstream coil 50b may be configured and operable for deactivating an EAS tag and the upstream coil unit 50a may be configured and operable to sense an EAS tag. In operation, the upstream coil 50a senses the presence of an EAS tag even before the item is scanned thus alerting the system 10 that the item being scanned has an EAS tag. Once the scanner has read the optical code on the item and identified it, in the same motion, the item is passed through the deactivation field of the downstream coil unit 50b, which has been alerted by the upstream of the presence of the EAS tag, and which deactivates the EAS tag.

**[0036]** The coil unit 50a may be physically and electrically integrated into the scanner to a range of varying degrees. The unit is disposed laterally in a cavity between the weigh platter and the lower enclosure 24. The unit 50a is also disposed laterally of the lower window 26 to avoid interfering with the scan beam projected off the lower mirror array and through the lower window 26. The coil unit 50a is mounted on a mounting bracket or coil mount 56. The coil mount 56 is mounted onto a side of the lower enclosure 24.

**[0037]** The above-described construction is just one example for mounting and positioning the coil units 50a, 50b. In one alternative, the coil units 50a, 50b may be integrated into the lower enclosure 24 or mounted directly thereto. In another alternative, the coil units 50a, 50b may be mounted to or even integrated or otherwise incorporated into the platter 30.

**[0038]** Since the scanner may be installed in a checkout counter in either a left-to-right or right-to-left configuration, the coil unit 50a is preferably constructed to be interchangeable and usable in the position of the unit 50b. Figs. 7-12 illustrate an alternate embodiment for a system 100 in which the deactivator coil units are interchangeable.

**[0039]** The system 100 comprises a two plane scanner in the same configuration as the previous embodiment with a vertical window 142 disposed in the upper housing section 140 and a horizontal window 122 disposed in the weigh platter 130 of the lower housing section 120. The EAS coil unit 150 is disposed beneath the

weigh platter 130 mounted via the coil mount 156. Alternately, the system 100 may comprise a vertical scanner window 142 only (the lower window 122 omitted) the lower housing section 120 being configured with or without the weigh platter and scale. In yet another alternative, the unit may comprise a horizontal scanner, with the horizontal window 122 only, the upper housing section 140 being omitted.

**[0040]** Returning to describing the illustrated configuration illustrated, the weigh platter 130 is supported by a spider 135 which is operably connected to the load cell 110. The load cell is mounted onto a mounting block 116 to the lower enclosure 124.

**[0041]** The coil unit 150 is illustrated in Figs. 7-10 on the right side of the weigh platter 130, preferable for a left-to-right scanning. The spider 135 has a U-shaped construction, with the central portion 135a disposed over the load cell 110, and a first lateral extension 135b disposed at the front of the weigh platter 130 and second lateral extension disposed at the rear of the weigh platter 130.

**[0042]** The system 100 is readily convertible to a right-to-left configuration. Figs. 11-12 illustrate the system 100 of Figs. 7-10 reconfigured for a right-to-left scanning configuration. In Figs. 11-12 the coil unit 150 and mount bracket 156 have been moved to the left side of the housing. The spider 135 has also been rotated with the central portion 135a shifted to the right side of the housing, with the load cell 110 and mount 116 also to the right side of the housing. The lateral extensions 135b and 135c of the spider 135 maintain a support position below the weigh platter 130 and on opposite sides of the coil unit 150.

**[0043]** It is anticipated that the unit 100 may preferably be configured upon ordering at the manufacturer, and then assembled in the selected configuration (left-to-right or right-to-left) as ordered. By having the components being interchangeable, only a single configuration for each of (1) coil unit 150, (2) coil mount 156, (3) spider 135, (4) load cell 110, and (5) bracket 116. The coil unit 150 is connected by a suitable connector, such as an electrical cable, to electronics in the unit 100 such as a printed circuit board disposed in the lower housing section 120. Alternately the unit may be configured in the filed.

**[0044]** In order to convert from left-to-right configuration to right-to-left configuration, the weigh platter 130 is removed to gain access to the other components, and then the coil unit 150, coil mount 156, spider 135, load cell 110, and bracket 116 are removed. The bracket 116 is then reinstalled onto the right side

and the load cell 110 is mounted to the bracket 116. The spider 135 is rotated 180° and secured to the load cell 110. Finally the coil mount 156 is installed on the left side and the coil unit 150 reinstalled onto the coil mount. The electrical connections to the load cell 110 and coil unit 150 are reconnected as required. The cables may either be provided with alternate cable connection points on the unit or the cables may be of sufficient length to reach the load cell 110 or coil unit 150 in the alternate positions.

**[0045]** The scale system with load cell is only one example of a scanner-scale configuration. For example, in an alternative embodiment where the coil unit(s) is/are mounted to the weigh platter, the weighing mechanism would weigh the coil unit(s) along with the weigh platter and any items placed thereon. The weight calibration would then adjust for the additional weight of the coil unit(s) mounted thereon. Of course, the system does not require the scale and weigh platter. For example, scanners such as the Magellan® SL scanner are sold in scanner-scale and scanner-only versions. Thus the platter of any of the embodiments may merely comprise a scanner surface. The scanner may comprise a single plane horizontal scanner (with a horizontal window disposed in the counter surface below a scan volume) with the deactivation unit(s) installed therein, or a single plane vertical scanner (with a vertical window disposed to one side of the scan volume) with the deactivation unit(s) installed therein.

**[0046]** Fig. 13 illustrates another embodiment for configuring deactivation coil unit(s) on a multiplane (having both a vertical window 242 and a horizontal window 222) or vertical scanner (having only a vertical window 242, the lower housing section 220 and/or the horizontal window 222 being omitted). The unit 200 specifically illustrated in Fig. 13 is a multiplane scanner such as the Magellan® scanners available from PSC Inc. having an upper housing section 240 containing a vertical window 142 and a lower housing section 220 containing a horizontal window 222. The windows 242 and 222 are disposed in an L-shape and form a scan volume therebetween. Alternately, the unit may be a vertical scanner only with the horizontal window 222 omitted (with or without a weigh platter, or with or without a horizontal section). According to a first embodiment, a coil unit 250a is placed in the upper housing section 240 behind the window 242 on the right side of the section 240. Preferably in a left-to-right scanning configuration, the coil unit 250a is disposed

generally downstream of the scan volume, serving to deactivating an item's EAS tag after the item's optical code has been read by the scanner.

**[0047]** In a second embodiment, a coil unit 250b is placed in the upper housing section 240 behind the window 242 on the left (lateral) side of the section 240. Preferable for a right-to-left scanning configuration, the coil unit 250b is disposed generally downstream of the scan volume, serving to deactivating an item's EAS tag after the item's optical code has been read by the scanner.

**[0048]** In a third embodiment, the system 200 is provided with two coil units 250a, 250b. In one configuration, the upstream coil unit is operative to sense presence of an EAS tag and the downstream coil unit is operative to deactivate an EAS tag. Alternately, both coil units (upstream and downstream) may be operative to deactivate EAS tags according to a suitable operations protocol.

**[0049]** The coil units 250a, 250b are preferably of the same configuration and interchangeable. Thus a single coil unit 250a disposed on the right side may be readily removed and reinstalled on the left side thus converting the unit 200 from a left-to-right configuration to a right-to-left configuration or a single coil unit 250b disposed on the left side may be readily removed and reinstalled on the right side thus converting the unit 200 from a right-to-left configuration to a left-to-right configuration.

**[0050]** The enclosure of the units 250a, 250b may be integrated within the upper housing section 240 or may be removably connected on the outer surface of the enclosure. The housing section 240 may be formed with detents or connectors for accommodating physical mounting and electrical connection of the coil unit 250. Preferably the coils units 250a, 250b are preferably of the same configuration and interchangeable. Thus a single coil unit 250a disposed on the right side may be readily removed and reinstalled on the left side thus converting the unit 200 from a left-to-right configuration to a right-to-left configuration or a single coil unit 250b disposed on the left side may be readily removed and reinstalled on the right side thus converting the unit 200 from a right-to-left configuration to a left-to-right configuration.

**[0051]** Figs. 14-15 illustrate yet another configuration for a reader/EAS deactivation unit 300 providing multiplane deactivation. The unit 300 comprises either a vertical scanner (no horizontal window), or a multiplane scanner (vertical and horizontal windows 342, 322) with housing sections and windows arranged in a



generally L-shape. The scanner housing 310 has (a) an upper housing section 340, (b) a lower housing section 320, and (c) an EAS deactivation unit comprised of two parts: (1) a lower unit 350a disposed in the cavity within the lower housing section 320 below the weigh platter 330, and to one side of the horizontal window 322 and (2) an upper unit 350b arranged vertically next to the vertical window 342 in upper housing section 340. As in the previous embodiment, the system 300 may be configured with a single deactivation unit on one side of the windows 322, 342 or with two deactivation units, one on either side of the windows 322, 342.

**[0052]** According to a first embodiment, the lower deactivation unit 350a is placed on the left side of the lower housing section 320. Preferably in a right-to-left scanning configuration, the deactivation unit 350a is disposed generally downstream of the scan volume, serving to deactivating an item's EAS tag after the item's optical code has been read by the scanner. In order to provide better coverage for EAS tag deactivation, a second deactivation unit 350b is disposed in the upper housing section 340, also to the left side of the vertical window 342 and generally perpendicular to the first deactivation unit 350a. The deactivation units 350a and 350b thus form a generally L-shape creating a deactivation field better corresponding to the scan field. The angle at or off of 90° may be selected by the designer for the particular scanner configuration. The units 350a and 350b may be separate units, or they may be physically and/or electrically connected.

**[0053]** The system 300 is illustrated in Fig. 14 installed in a checkout counter. A retail checkstand, applicable to both the system 300 of Figs. 14-15 as well as the other embodiments described herein, would typically include a cash register with display screen, a keypad, and a checkout counter. The system 300 in Fig. 14 is illustrated installed within a checkout counter 375, the counter surface including a conveyor 380 on the upstream side for transporting items to the housing 320 for a right-to-left scanning operation. The scanner housing 310 is preferably installed in the checkout counter such that the window 322 and platter 330 are flush with the top surface of the counter 375.

**[0054]** In a preferred configuration, one of the units (for example lower unit 350a) comprises a coil unit having a central core of magnetically-active material (e.g. iron) with an outer wire winding through which current is passed to create the deactivating magnetic field. The second unit (in this example upper unit 350b) may comprise another coil unit, but may alternately comprise merely a core of magnetically active.

material, that is, a bare core unit without windings. The bare core unit 350b acts in concert the coil unit 350a to steer the magnetic field produced by the coil unit 350a into the scan volume. Alternately, the coil unit may be disposed in the upper housing section and the bare core unit disposed in the lower housing section.

**[0055]** In configurations similar to alternatives described for previous embodiments, the units 350a, 350b may be placed on either the left side which is preferable for a right-to-left scanning configuration, or on the right side which is preferable for left-to-right scanning, as it is believed to be preferable to locate the deactivation units generally downstream of the scan volume, serving to deactivating an item's EAS tag after the item's optical code has been read by the scanner. Alternately, the system 300 may be provided with unit pairs on both left and right sides. In one configuration, the upstream unit pair is operative to sense presence of an EAS tag and the downstream unit pair is operative to deactivate an EAS tag. Alternately, both unit pairs (upstream and downstream) may be operative to deactivate EAS tags according to a suitable operations protocol.

**[0056]** The upper unit 350b may be integrated within the upper housing section 340 (e.g. formed into the enclosure itself) or may be constructed to be mounted to the inside surface, or to the outside front or lateral surface of the enclosure. The upper housing section 340 may be formed with detents or connectors for accommodating physical mounting and electrical connection of the coil unit 350. Preferably the coil units are of the same configuration and interchangeable such that a single coil unit disposed on the right side may be readily removed and reinstalled on the left side and vice versa. Similarly, core units should be interchangeable as between the left and right sides.

**[0057]** Figs. 16-17 illustrate another configuration for a combined EAS and bar code reader 400. The data reader 410 is illustrated as an L-shaped scanner with a lower section 420 containing a horizontal scan window 422 disposed in the horizontal surface or weigh platter 430, and an upper section 440 containing a vertical scan window 442.

**[0058]** The deactivation unit 450 is disposed longitudinally along the direction of product movement and generally at the intersection between the lower section 420 and the upper section 440. The deactivation unit 450 is oriented longitudinally such that its long axis is arranged parallel to the scan direction that items are swept through the scan volume. This configuration may provide for a single configuration

working equally well for right-to-left or left-to-right sweep directions. The deactivation field generated may more closely match the scan volume, particularly for leading and trailing edges. The length of the unit 450 may be further extended to extend the deactivation zone enabling items to remain in the deactivation zone for a longer period of time as the item is swept through the scan volume. Such an extended deactivation zone may also more closely match the scan volume for leading and trailing side labels. This position for the deactivation unit 450 may also simplify scale integration.

**[0059]** Figs. 18-19 illustrate another configuration for a combined EAS and bar code reader 500. The data reader 510 is illustrated as an L-shaped scanner with a lower section 520 containing a horizontal scan window 522 disposed in the horizontal surface or weigh platter 530, and an upper section 540 containing a vertical scan window 542.

**[0060]** The deactivation unit 550 is disposed longitudinally along the scan direction of item sweep and in the lower housing section 520 distal from the upper housing section 540 and next to the operator (also know as "checker side"). The long axis of the deactivation unit 550 is arranged parallel to the direction through items are swept through the scan volume. This configuration may also provide for a single configuration working equally well for right-to-left or left-to-right sweep directions. The deactivation field generated may more closely match the scan volume, particularly for leading and trailing edges. The length of the unit 550 may be further extended to extend the deactivation zone enabling items to remain in the deactivation zone for a longer period of time as the item is swept through the scan volume. Such an extended deactivation zone may also more closely match the scan volume for leading and trailing side labels. This position for the deactivation unit 550 may also simplify scale integration.

**[0061]** Figs. 20-21 illustrate yet another configuration for a combined EAS and bar code reader 600. The data reader 610 is illustrated as an L-shaped scanner with a lower section 620 containing a horizontal scan window 622 disposed in the horizontal surface or weigh platter 630, and an upper section 640 containing a vertical scan window 642.

**[0062]** The deactivation unit 650 is disposed longitudinally along the direction of product movement and in a top portion of the upper section or bonnet 640 distal from the lower section 620. The long axis of the deactivation unit 650 is arranged parallel

to the sweep direction in which items are passed through the scan volume. This configuration may also provide for a single configuration working equally well for right-to-left or left-to-right sweep directions. The deactivation field generated may more closely match the scan volume, particularly for leading and trailing edges. The length of the unit 650 may be further extended to extend the deactivation zone enabling items to remain in the deactivation zone for a longer period of time as the item is swept through the scan volume. Such an extended deactivation zone may also more closely match the scan volume for leading and trailing side labels. In this upper location, the deactivation unit 650 is separated from the metal casting and weigh platter 630 so that magnetic field strength may be enhanced. Scale integration may also be simplified.

**[0063]** With respect to scale integration, the above embodiments of Figs. 1-12 illustrate a single load cell design. Figs. 22-23 illustrate a combined EAS and bar code reader with scale system 700 having two load cells 715, 717. The weigh platter (shown removed) which contains the horizontal window 722) rests on a front spider or bar 735 and a rear spider or bar 737. The front spider 735 is supported by the first load cell 715. Platter levelers 733, 734 are placed between the load cell 715 and the spider 735 for providing leveling adjustment of the weigh platter. Similarly, rear spider 737 is supported by the second load cell 717. Platter levelers 738, 739 are placed between the load cell 717 and the spider 737 for providing leveling adjustment of the weigh platter.

**[0064]** Fig. 24 illustrates yet another combined EAS and bar code reader with scale system 800 having a single load cell 815. The weigh platter (shown removed but which contains the horizontal window 822) rests on load posts 833, 834, 836, 837 which extend toward the bottom of the lower housing section 820 connecting onto spider 835. The spider 835 is in turn mounted onto the load cell 810. The load cell 810 is mounted onto a base 856 or chassis such as the bottom of the housing section 820.

**[0065]** By separating the load cell 810 and spider 835, additional space is provided for the deactivation coil 850 (or multiple coils as in previous embodiments) simplifying construction. The additional space also simplifies interchangeable configurations such as where the deactivation unit 850 disposed on the left lateral side of the window 822 needs to be switched to the right lateral side.

71073-161

**[0066]** In a preferred configuration, the core unit comprises a block of magnetically active material having a generally rectangular cross-section. In one configuration, the core is about 3 in (7.6cm) wide, 1.5 in (3.8cm) deep and 9 in (22.9cm) long. The unit is preferably elongated, having a length at least about three times its width. Alternately, the core may have a circular or oval cross-section of about 1.5 in (3.8cm) in diameter. The housing for the core unit may be made of a variety of materials but is preferably injection molded from a non-magnetically active material such as polystyrene or polycarbonate.

**[0067]** The systems disclosed may alternately comprise not only EAS deactivation units, but also activation units or combined activation/deactivation units usable with activatable EAS tags. In addition, the EAS tag deactivators/activators described may include deactivation or activation of various types of EAS tags such as magnetoacoustic, magnetomechanical, magnetostrictive, RF (e.g. RFID), microwave, and harmonic type tags. Moreover, in each of the above embodiments, the deactivation units may comprise coil units with or without internal (magnetically active) core. For example, deactivation coils without internal core are described in U.S. Patent No. 5,917,412. The deactivation units of the above embodiments may be controlled and operated by any suitable scheme as known by one skilled in the art, including but not limited to those schemes disclosed in U.S. Patent Nos. 5,917,412; 6,281,796; 6,169,483; and 5,059,951.

**[0068]** In the various embodiments described above, the data reader unit has been generally described as a two window L-shaped bar code scanner, but other types of data readers may be combined with the EAS deactivation/activation system. The data reader may be for example a laser bar code scanner, an imaging reader, or other type of reader for reading optical codes, reading tags, or otherwise identifying items being passed through a scan/read zone.

**[0069]** Thus the present invention has been set forth in the form of its preferred embodiments. It is nevertheless intended that modifications to the disclosed scanning systems may be made by those skilled in the art without altering the essential inventive concepts set forth herein.

**[0070]** It will be obvious to those having skill in the art that many changes may be made to the details of the above-described embodiments without departing from the

underlying principles of the invention. The scope of the present invention should, therefore, be determined only by the following claims.

71073-161

CLAIMS:

1. A checkout system for data reading and electronic article security (EAS) deactivation, comprising
- a housing including a lower housing section containing a lower window oriented generally horizontally and an upper housing section containing a upper window oriented generally vertically;
- a data reader disposed in the housing to read an item through the upper and lower windows as the item is passed through a read volume defined between the upper and lower windows;
- an EAS deactivation unit disposed in the housing, wherein the deactivation unit comprises a magnetic coil unit including a central portion and outer windings disposed about the central portion, the magnetic coil unit generating a magnetic field for deactivating electronic security tags being located in at least a portion of the read volume.
2. A checkout system according to claim 1 wherein the data reader comprises a first barcode scanner portion disposed in the lower housing section for generating first scan lines that pass through the horizontal window and into the read volume and a second barcode scanner portion disposed in the upper housing section for generating second scan lines that pass through the vertical window and into the read volume.
3. A checkout system according to claim 2 further comprising
- a weigh platter suspended above the first barcode scanner portion, wherein the magnetic coil unit is disposed between the first barcode scanner portion and the weigh platter.
4. A checkout system according to claim 1 further comprising

71073-161

a controller that enables the EAS deactivation unit only after successful reading of an identification tag on an item being passed through the read volume.

5. A checkout system according to claim 1 wherein the magnetic coil unit includes outer windings disposed around a central core of magnetically-active material.
6. A checkout system according to claim 1 wherein the magnetic coil unit is formed with outer windings without a central core.
7. A checkout system according to claim 1 further comprising a scale assembly including a base portion and a weigh platter over the base portion, wherein the weigh platter includes an aperture;  
wherein the magnetic coil unit is disposed between the weigh platter and the base portion.
8. A checkout system according to claim 1 further comprising a weigh platter suspended above the lower housing section, wherein the EAS deactivation unit is disposed below the weigh platter.
9. A checkout system according to claim 8 further comprising a load cell supporting the weigh platter.
10. A checkout system according to claim 9 further comprising a platter window disposed in the weigh platter.
11. A checkout system according to claim 10 wherein the magnetic coil unit is disposed in the housing adjacent to and downstream of the platter window.
12. A checkout system according to claim 10 wherein the magnetic coil unit is disposed in the housing to a lateral side of the platter window.



71073-161

13. A checkout system according to claim 12 wherein the magnetic coil unit is mounted to be interchangeable as between one lateral side of the platter window and the other.

14. A checkout system according to claim 1, wherein the system is an  
5 integrated system for barcode reading and EAS tag deactivation wherein the data reader comprises a barcode reader for reading a barcode label on an item being passed through a read volume of the barcode reader.

15. A checkout system according to claim 14 wherein an item is passed  
10 through the read volume in a direction of item movement from a position upstream of the barcode reader to a position downstream of the barcode reader and wherein magnetic coil unit is disposed to a downstream lateral side of the lower window.

16. A checkout system according to claim 1 wherein the magnetic coil unit comprises separate sense and deactivation coils.

17. A method for checkout of an item bearing an optical code and having a  
15 deactivatable security tag, comprising the steps of:

passing the item along an item path and through a read volume of a data reader, the data reader being disposed in a housing;

reading the optical code on the item with the data reader through a window in the housing;

20 generating a security tag deactivation field with a security tag deactivation unit, the deactivation unit comprising a magnetic coil unit formed of outer windings arranged about a central core disposed in the housing, the deactivation field being located in the item path and at least partially overlapping the read volume for deactivating electronic security tags being passed through the read volume.

71073-161

18. A method according to claim 17 wherein once the data reader has read the optical code on the item and identified it, activating the deactivation field of the deactivation coil and deactivating the security tag.

19. A method according to claim 17 further comprising

5 generating a security tag detection field with a detection unit, the detection unit being disposed in the housing, and the detection field being located in the item path upstream of the read volume;

alerting the deactivation unit upon detection of a security tag.

20. A method according to claim 17 wherein the magnetic coil unit is formed  
10 with outer windings disposed about a central core, the magnetic coil unit being disposed in the housing to one lateral side and downstream of the window.

21. A checkout device comprising:

a scale assembly including a base portion and a weigh plate over the base portion, wherein the weigh plate includes an aperture;

15 a barcode reader between the base portion and the weigh plate, the barcode reader reading a barcode affixed to an item through the aperture in the weigh plate; and

a security label deactivation system disposed between the base portion and the weigh plate which deactivates a security label affixed to the item after the  
20 barcode is read by the barcode reader, the security label deactivation system integrated within the scale assembly,

wherein the security label deactivation system includes a magnetic coil assembly for sensing and deactivating the security label.

22. A checkout device according to claim 21, wherein the barcode reader  
25 enables the security label deactivation system following reading of the barcode.

71073-161

23. A checkout device according to claim 21 wherein the security label deactivation system is activated as the item travels along a path which crosses a barcode reader read zone above the aperture and continues above the plane of the weigh plate, in response to an enabling signal sent by the barcode reader upon  
5 successful read of the barcode affixed to the item, the security label deactivation system operating to deactivate the security label affixed to the item while the item continues traveling along the path.
24. A checkout device for reading optical codes on items being passed through a read volume, comprising  
10 an enclosure;  
a removable platter positioned over the enclosure and below the read volume, the platter including a platter window disposed therein;  
a data reader including a reader window disposed in the enclosure and below the platter window, the data reader reading an optical code on an item being  
15 passed through the read volume;  
a magnetic deactivation coil unit disposed between the platter and the data reader, the magnetic deactivation coil unit including a central portion and outer windings arranged about the central portion, the magnetic deactivation coil unit generating a magnetic field for deactivating an electronic article surveillance tag on  
20 the item being passed through the read volume.
25. A checkout device according to claim 24 wherein the central portion of the magnetic deactivation coil unit comprises a core of magnetically active material.
26. A checkout device according to claim 24 wherein the central portion of the magnetic deactivation coil unit is without an internal core.
- 25 27. A checkout device comprising

71073-161

an optical code reader including an upper portion having a substantially vertical aperture and a lower portion having a substantially horizontal aperture;

a platter suspended above the lower portion; and

a security label deactivation system including

5 a first magnetic coil unit disposed in the lower portion below the platter, the first magnetic coil assembly having a central portion with outer windings disposed about the central portion, the first magnetic deactivation coil unit generating a magnetic field for deactivating an electronic article surveillance tag, and

10 a second magnetic coil unit disposed in the upper portion, the second magnetic coil unit having a central portion with outer windings disposed about the central portion, the second magnetic deactivation coil unit generating a magnetic field for deactivating an electronic article surveillance tag.

28. A checkout device comprising:

15 a scale assembly including a base portion and a weigh plate over the base portion, wherein the weigh plate includes an aperture;

a barcode reader between the base portion and the weigh plate which reads a barcode through the aperture in the weigh plate;

a security label deactivation system; and

20 a controller that enables the security label deactivation system only after successful reading of the barcode,

wherein the security label deactivation system comprises a magnetic coil unit disposed between the weigh plate and the base portion, the magnetic coil unit including outer windings disposed around a central core.

71073-161

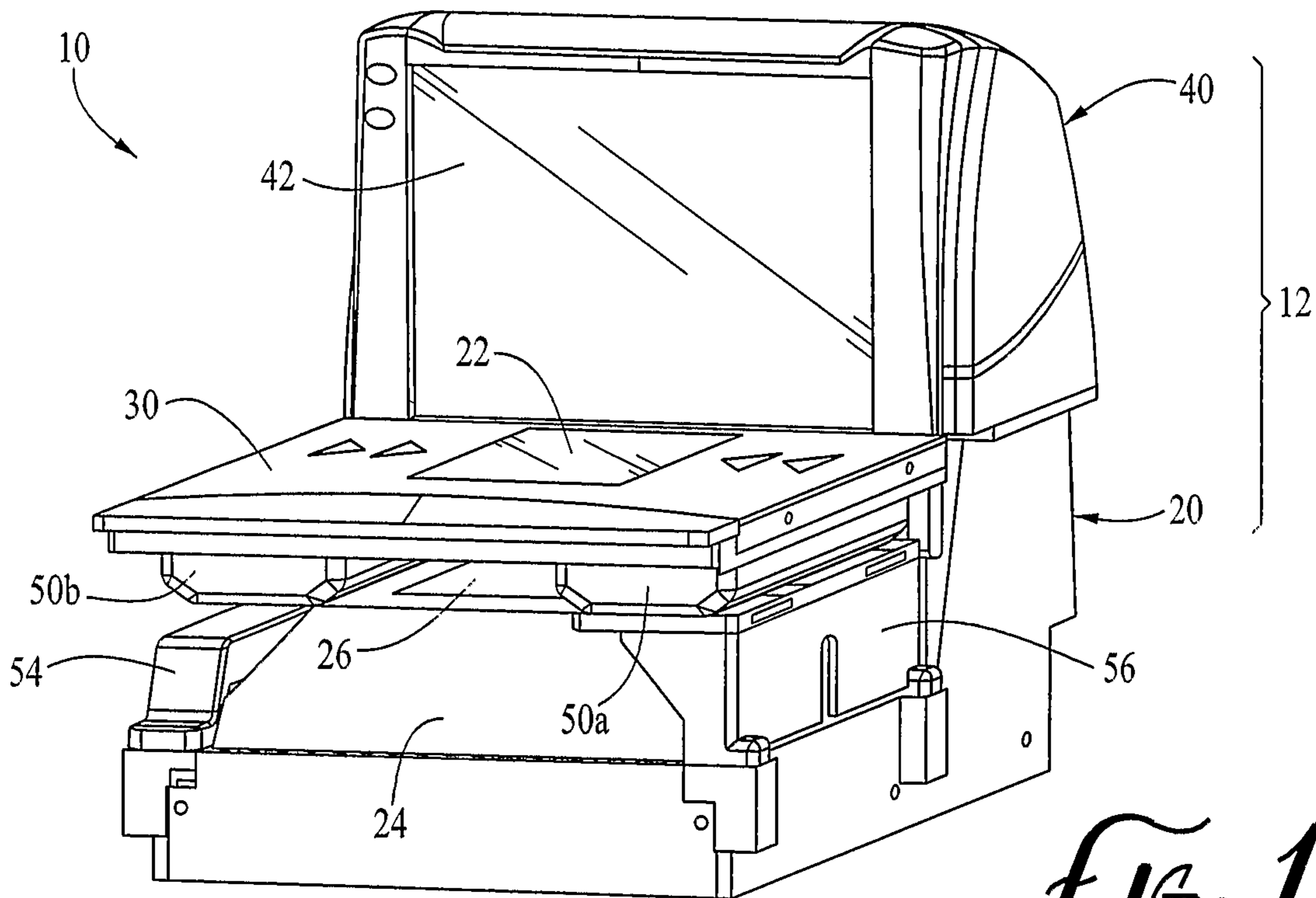
29. A checkout device according to claim 28 wherein the scale assembly further includes a load cell mounted in the base portion, the load cell supporting the weigh plate.

30. A checkout device comprising:

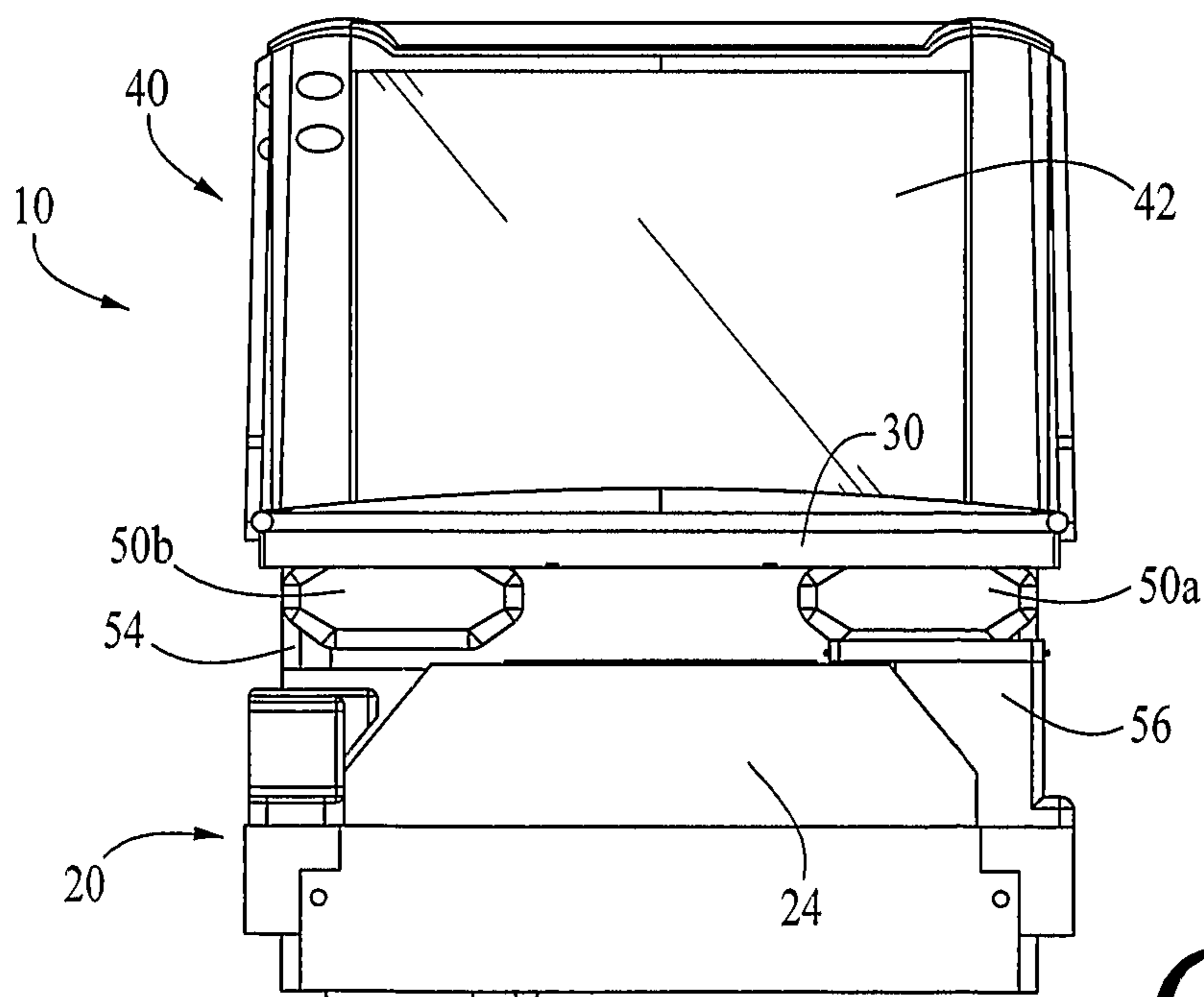
5 a barcode reader including a first portion having a substantially horizontal aperture and a second portion having a substantially vertical aperture;

a weigh platter suspended above the first portion; and

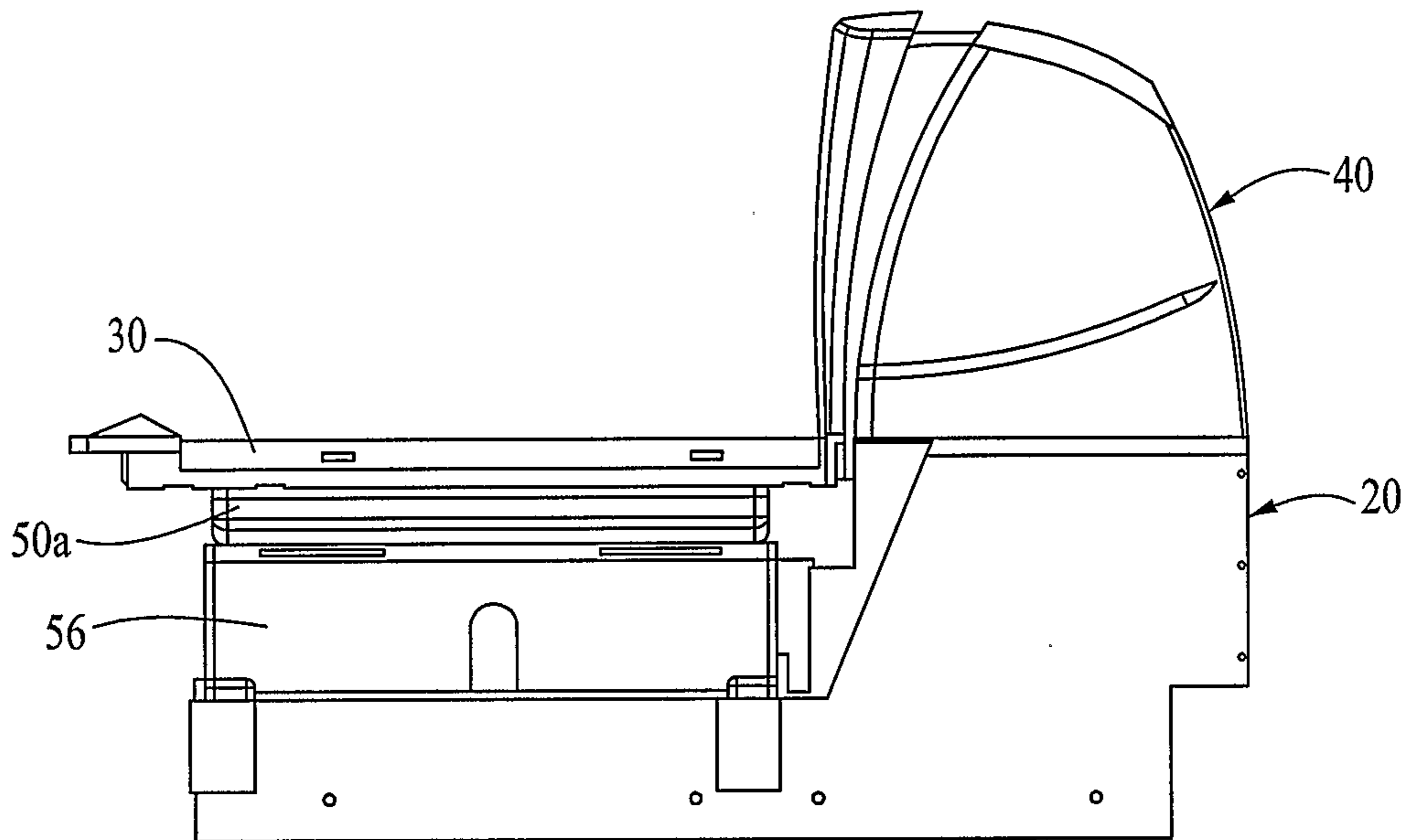
10 a security label deactivation system adjacent the first portion and under the weigh platter, wherein the security label deactivation system comprises a magnetic coil unit including a central portion and outer windings disposed about the central portion, the magnetic coil unit generating a magnetic field for deactivating electronic security tags.



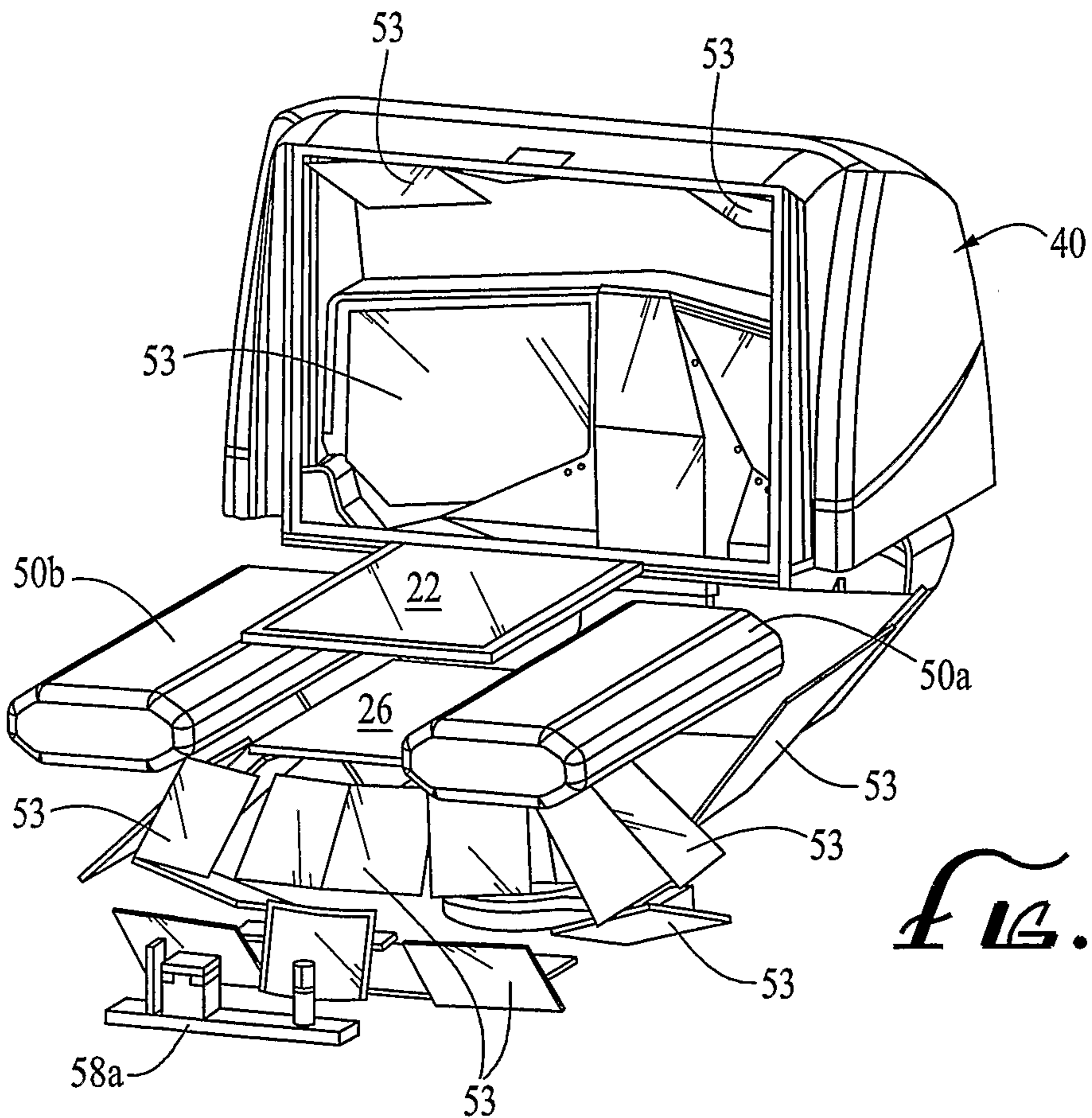
*FIG. 1*



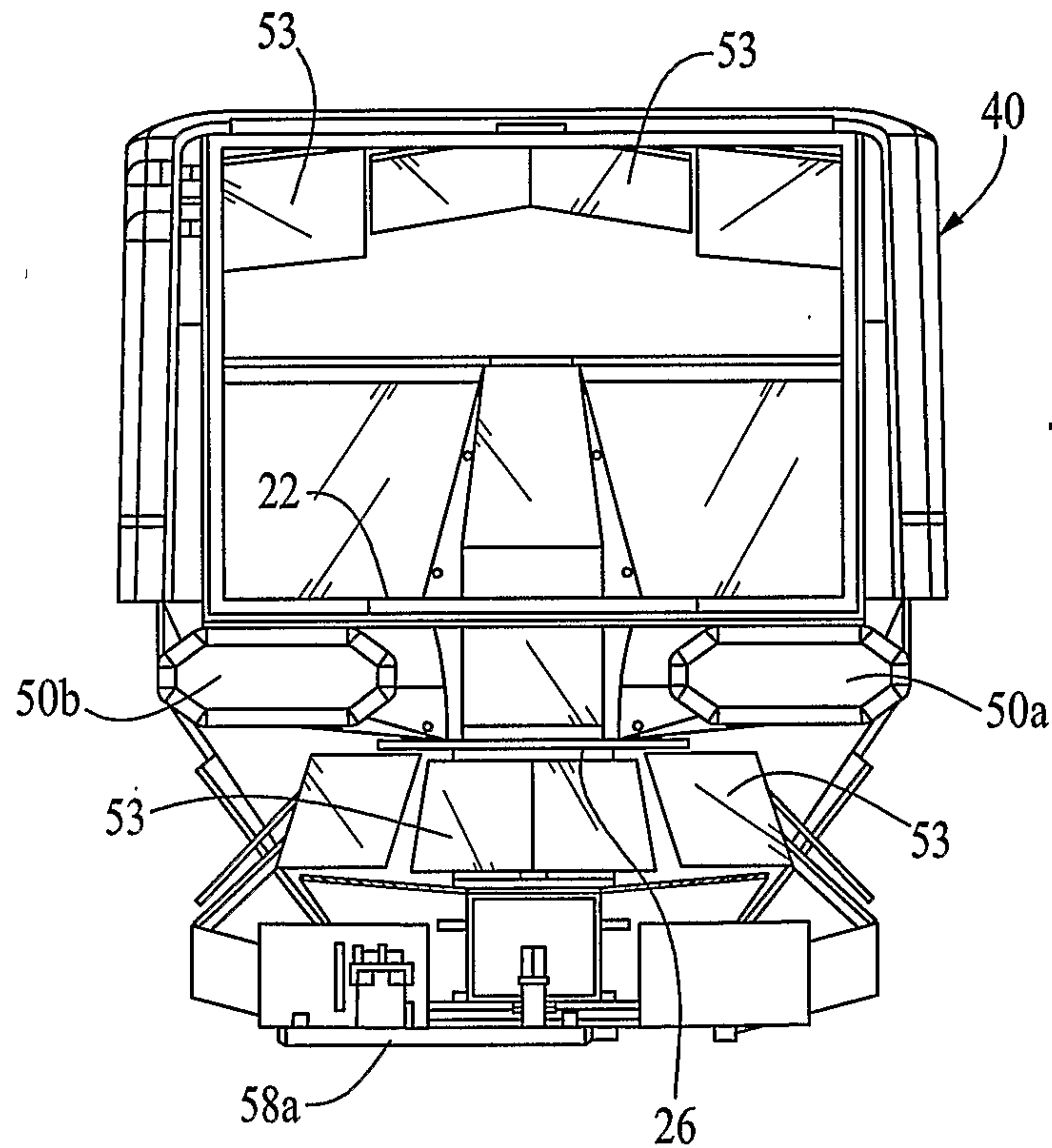
*FIG. 2*



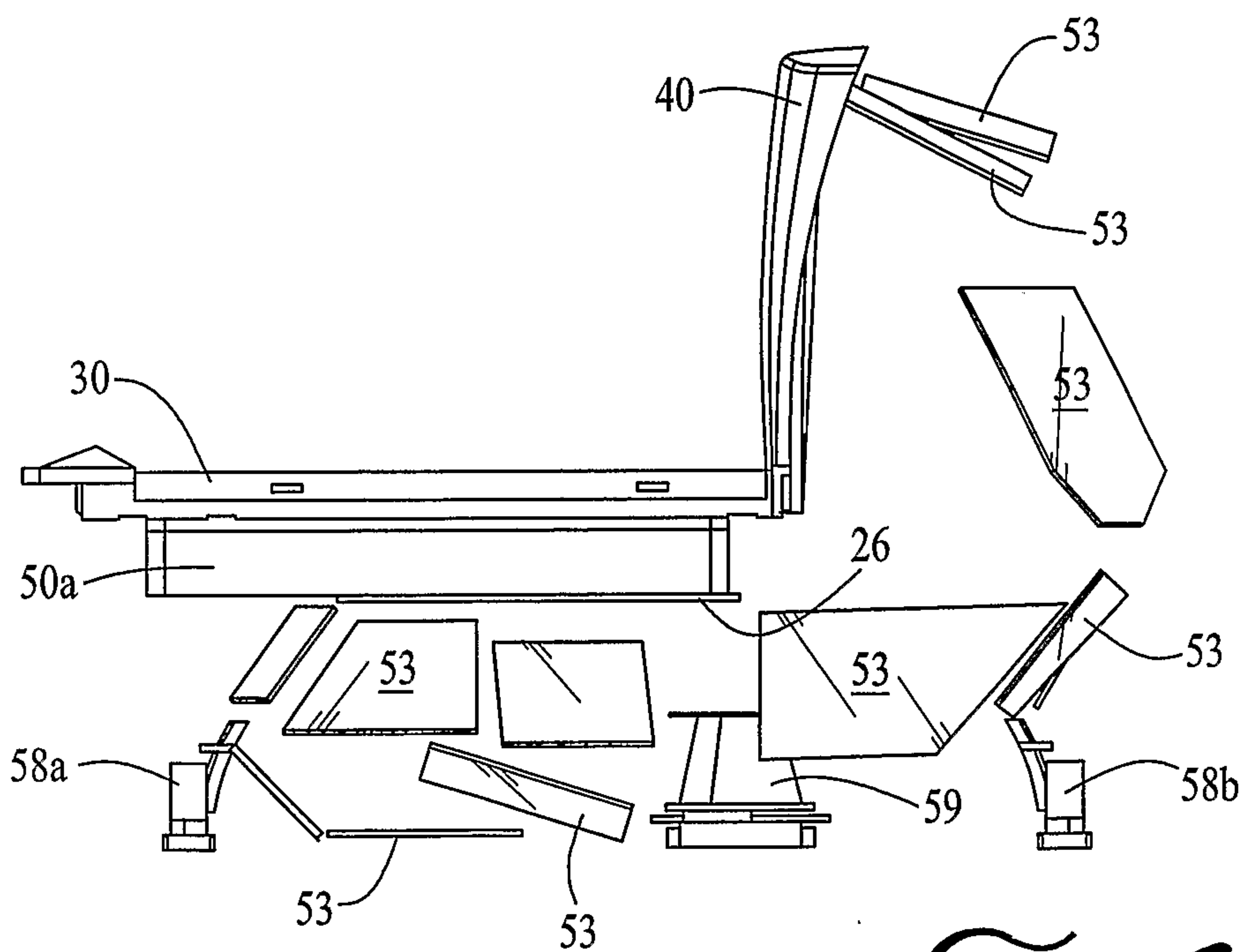
*FIG. 3*



*FIG. 4*

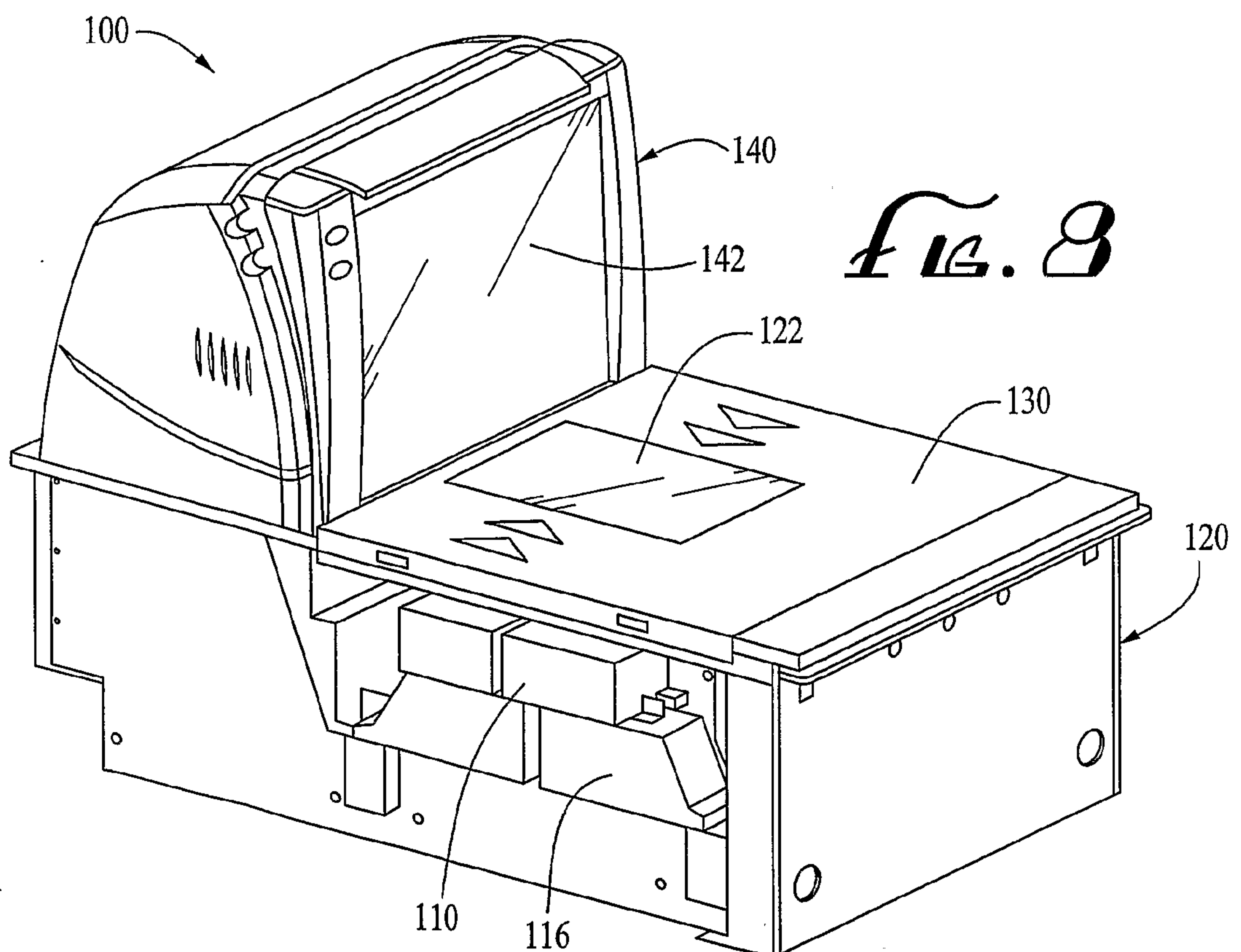
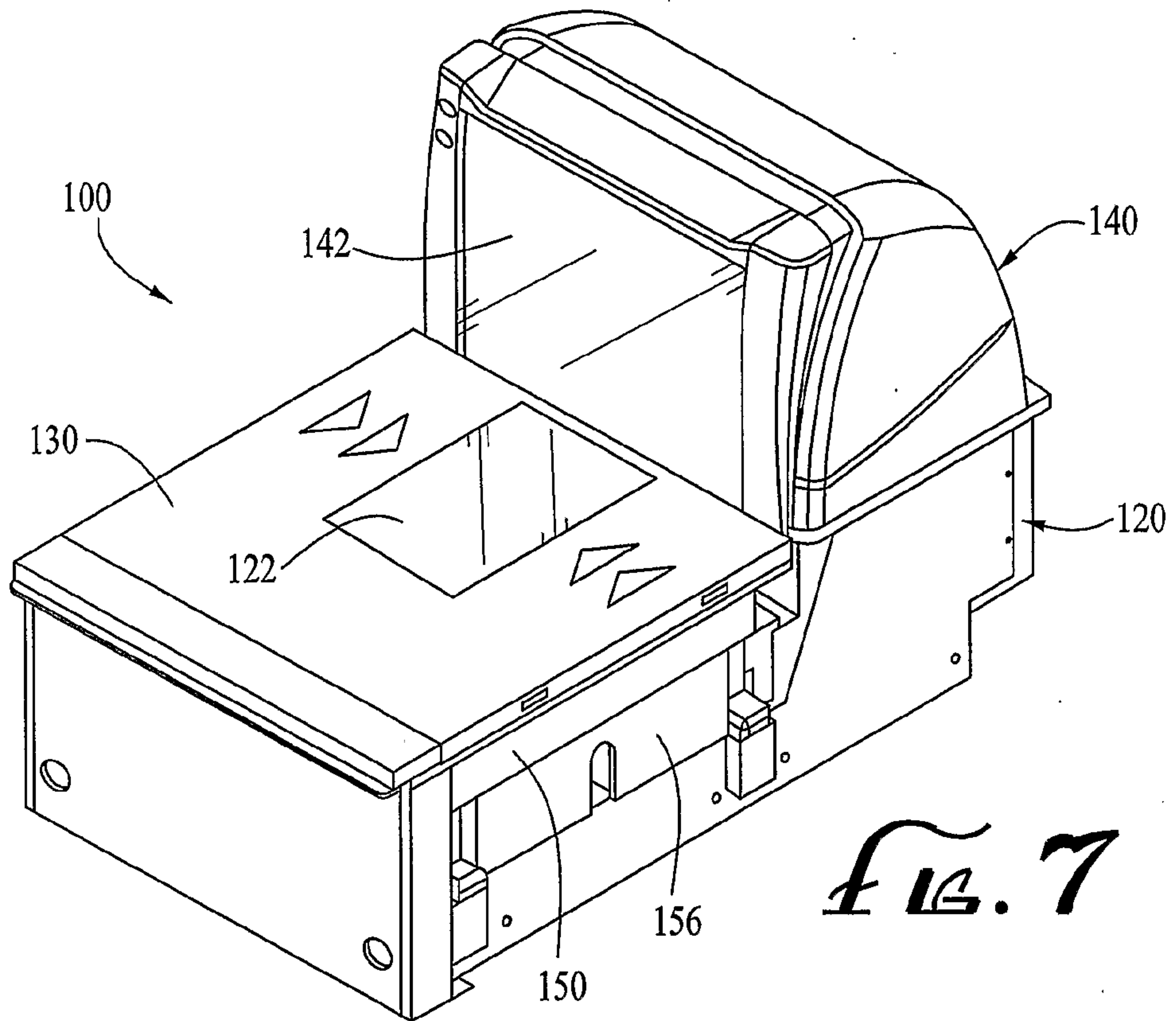


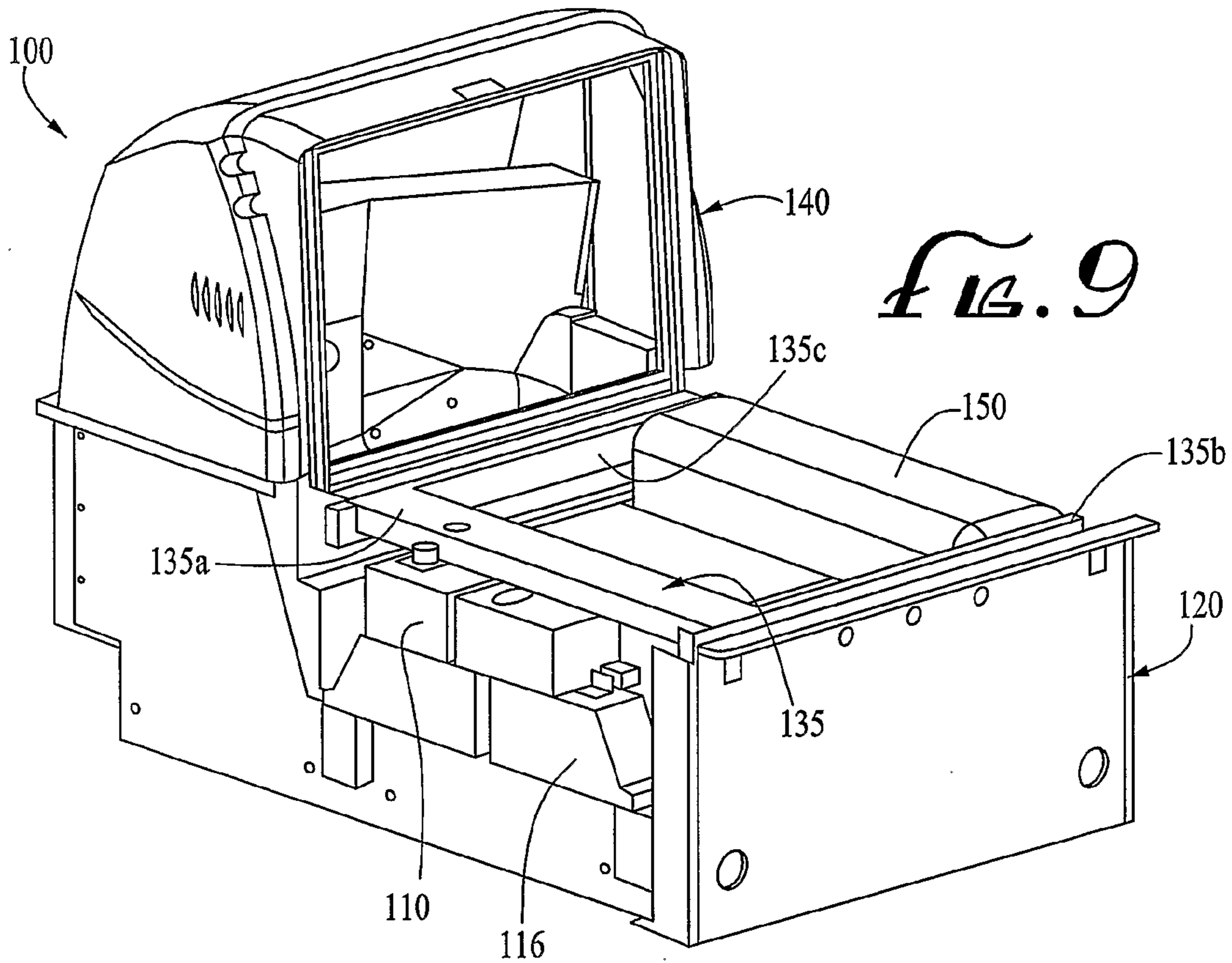
*FIG. 5*



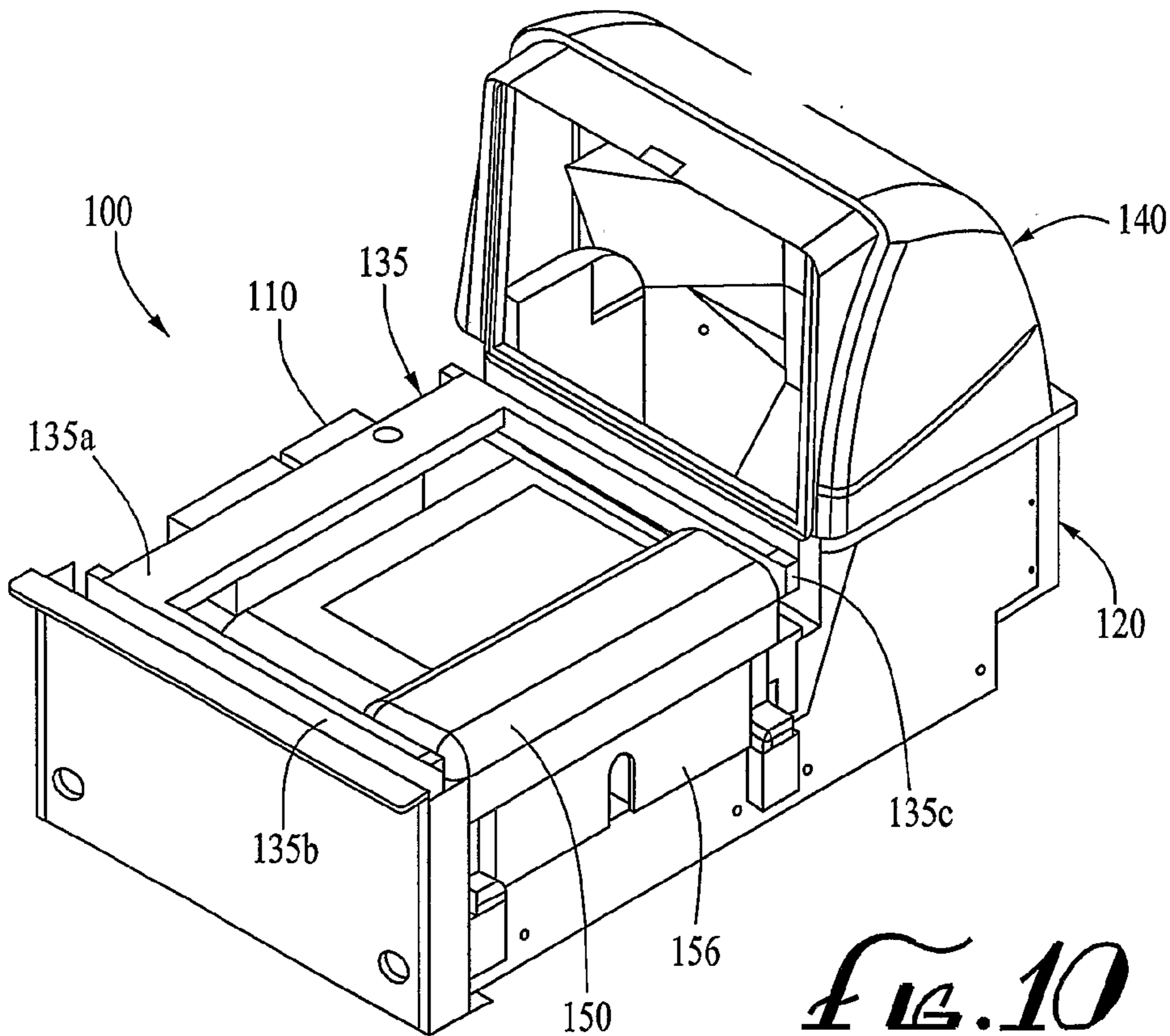
*FIG. 6*





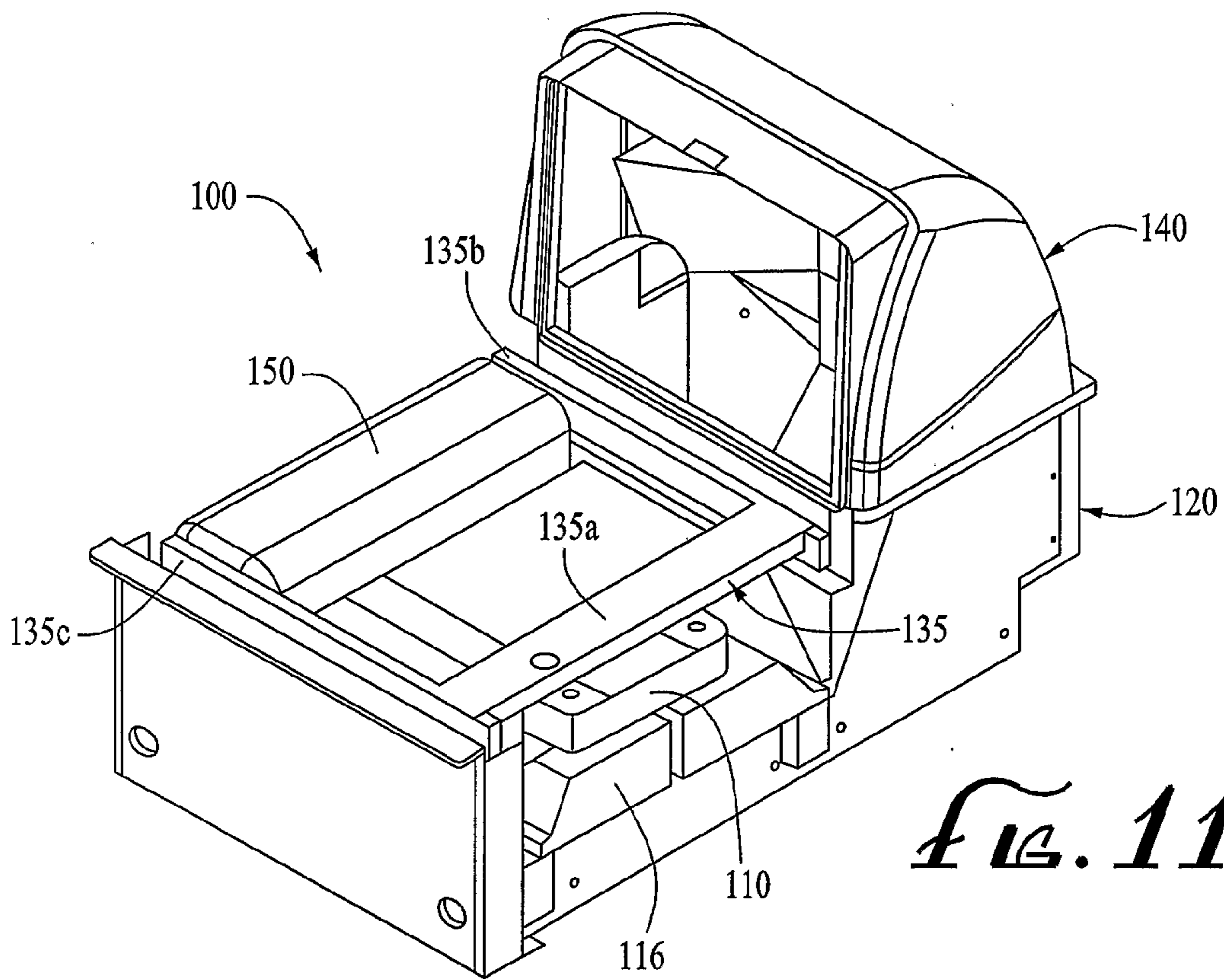


*Fig. 9*

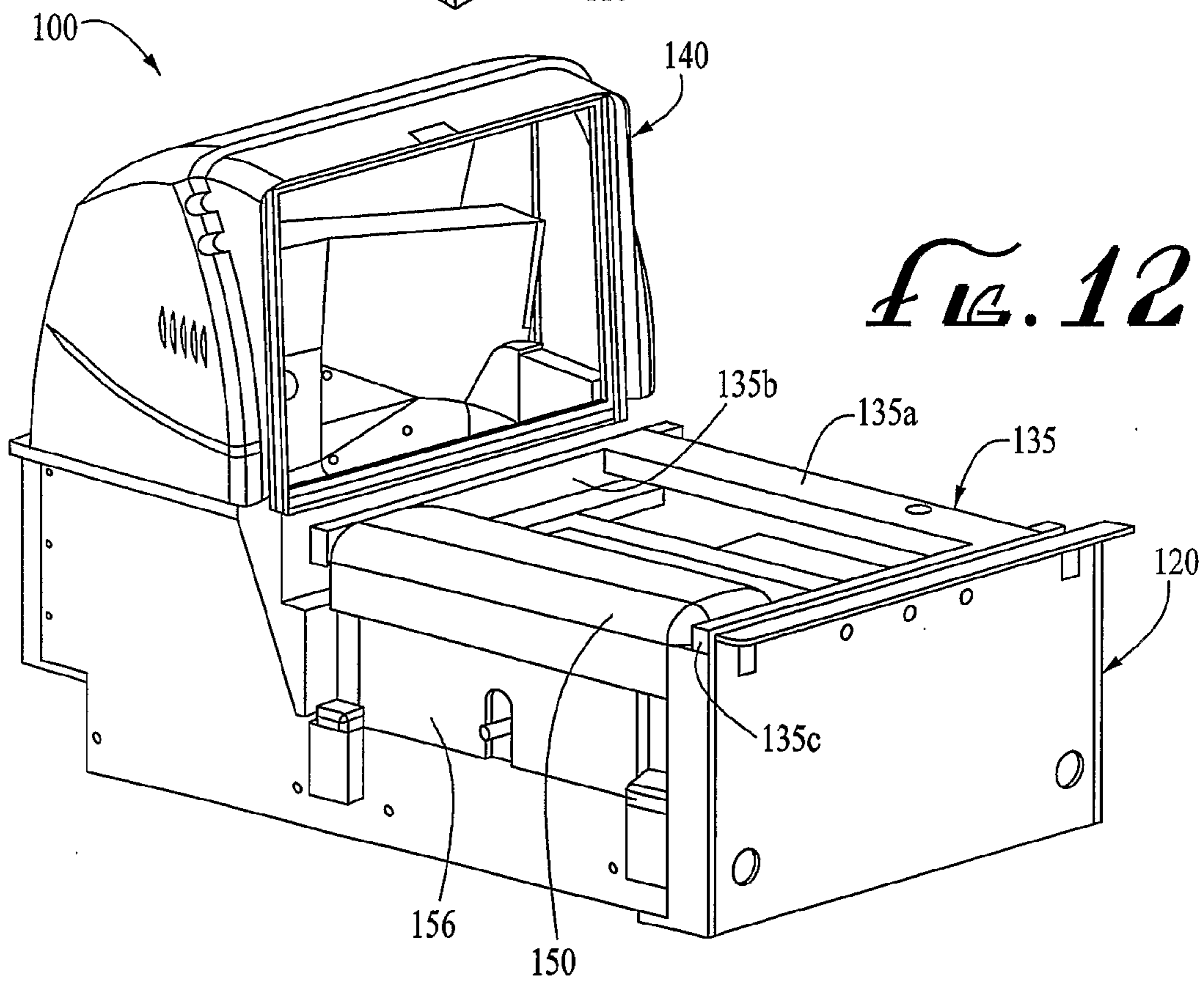


*Fig. 10*

6/13

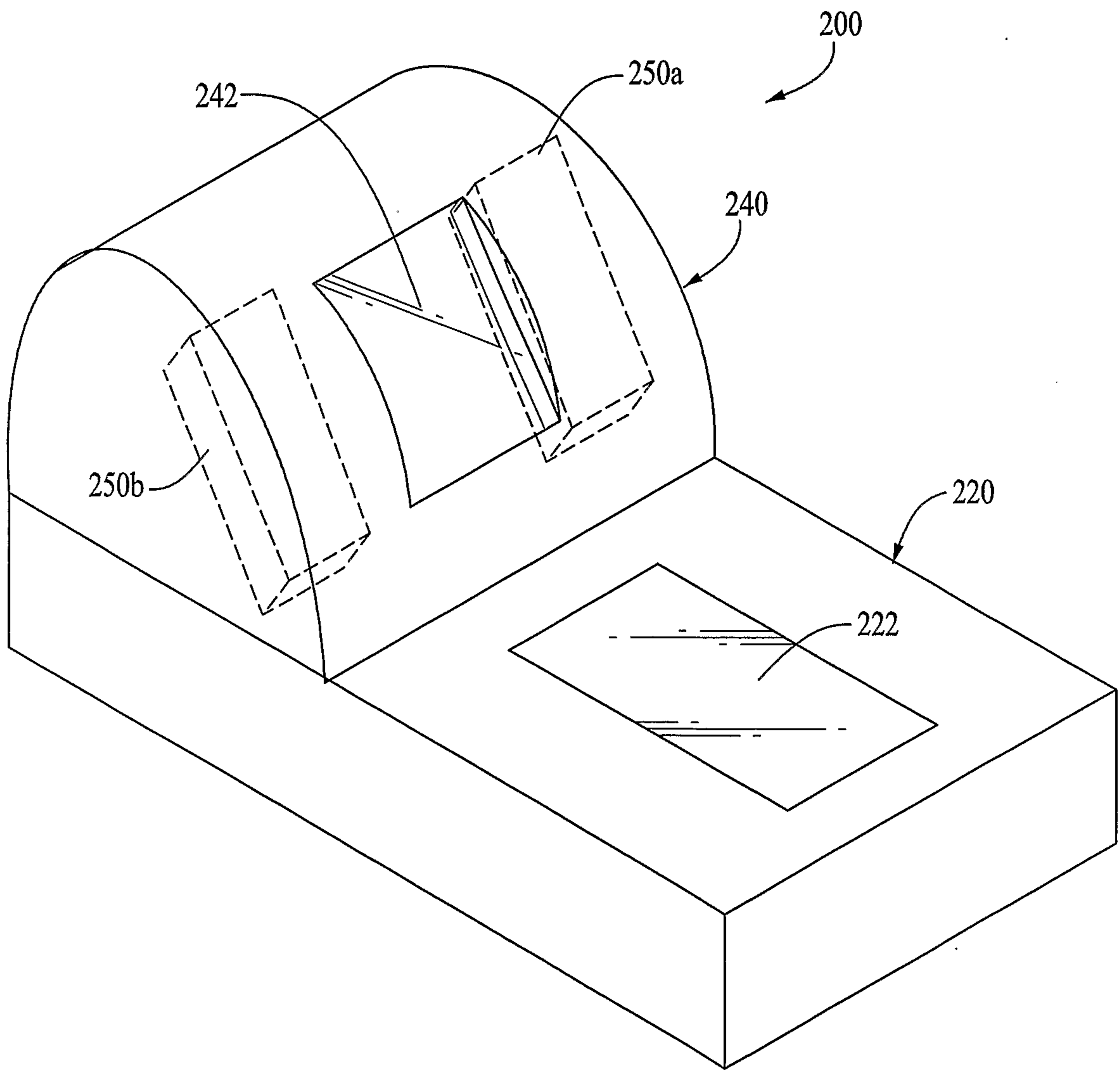


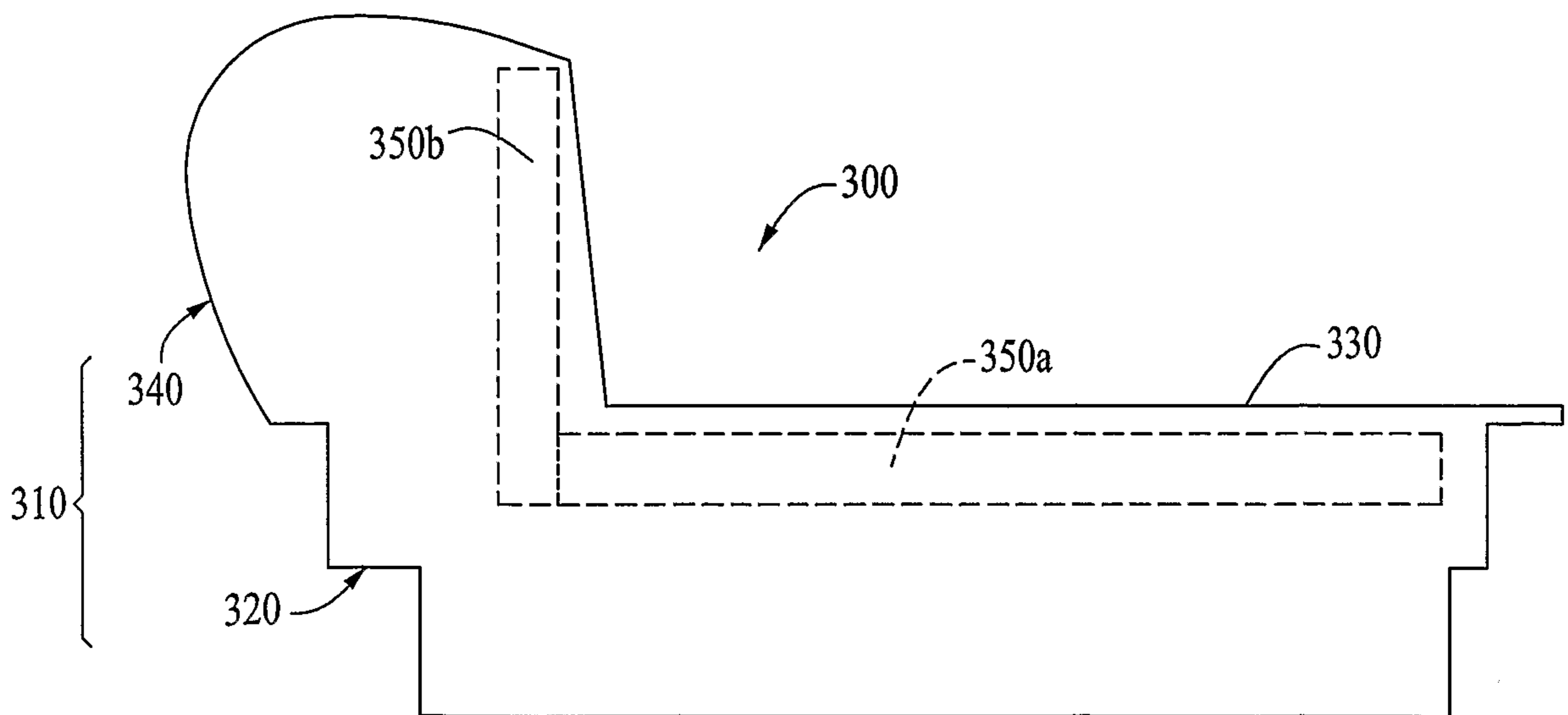
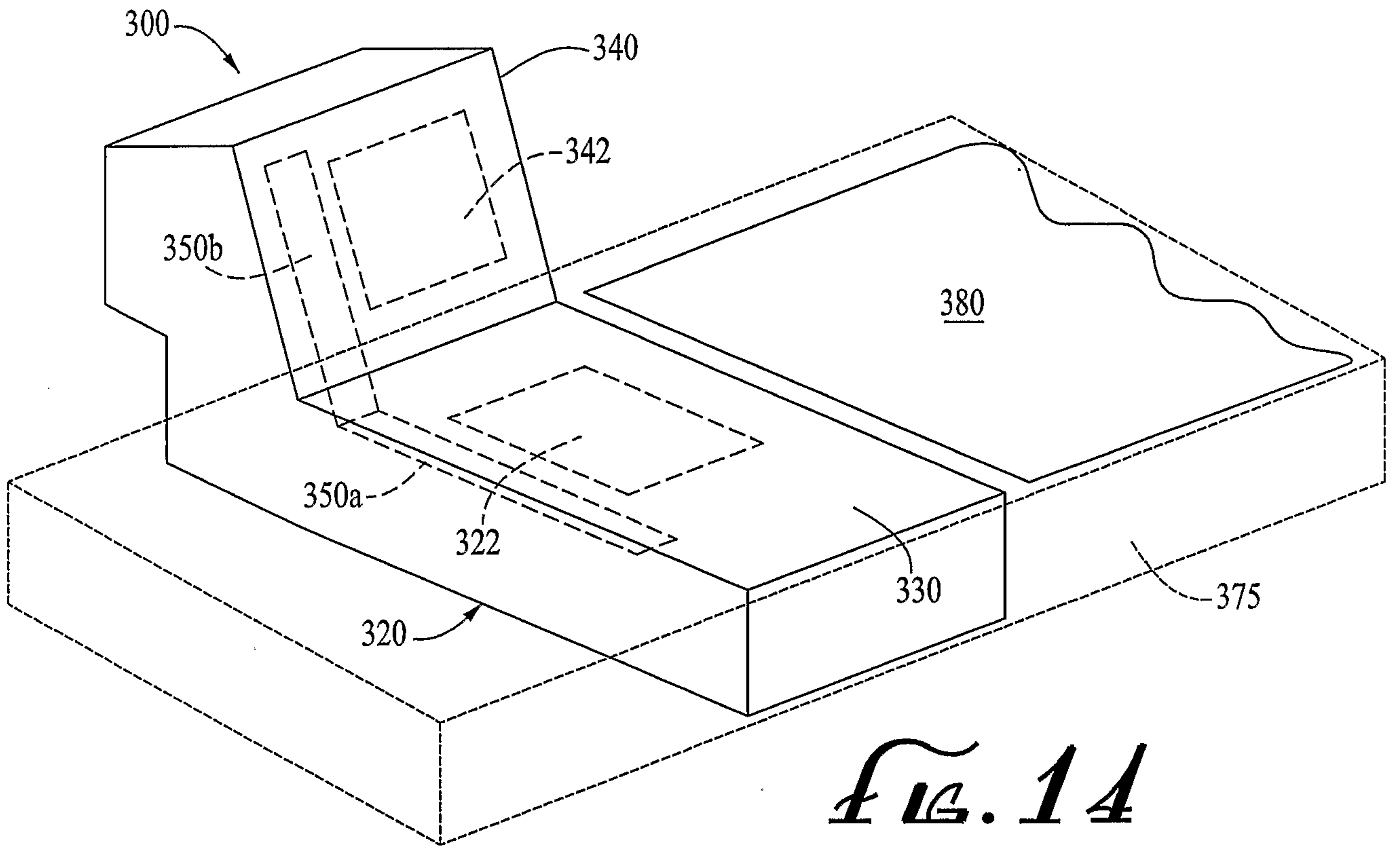
*Fig. 11*



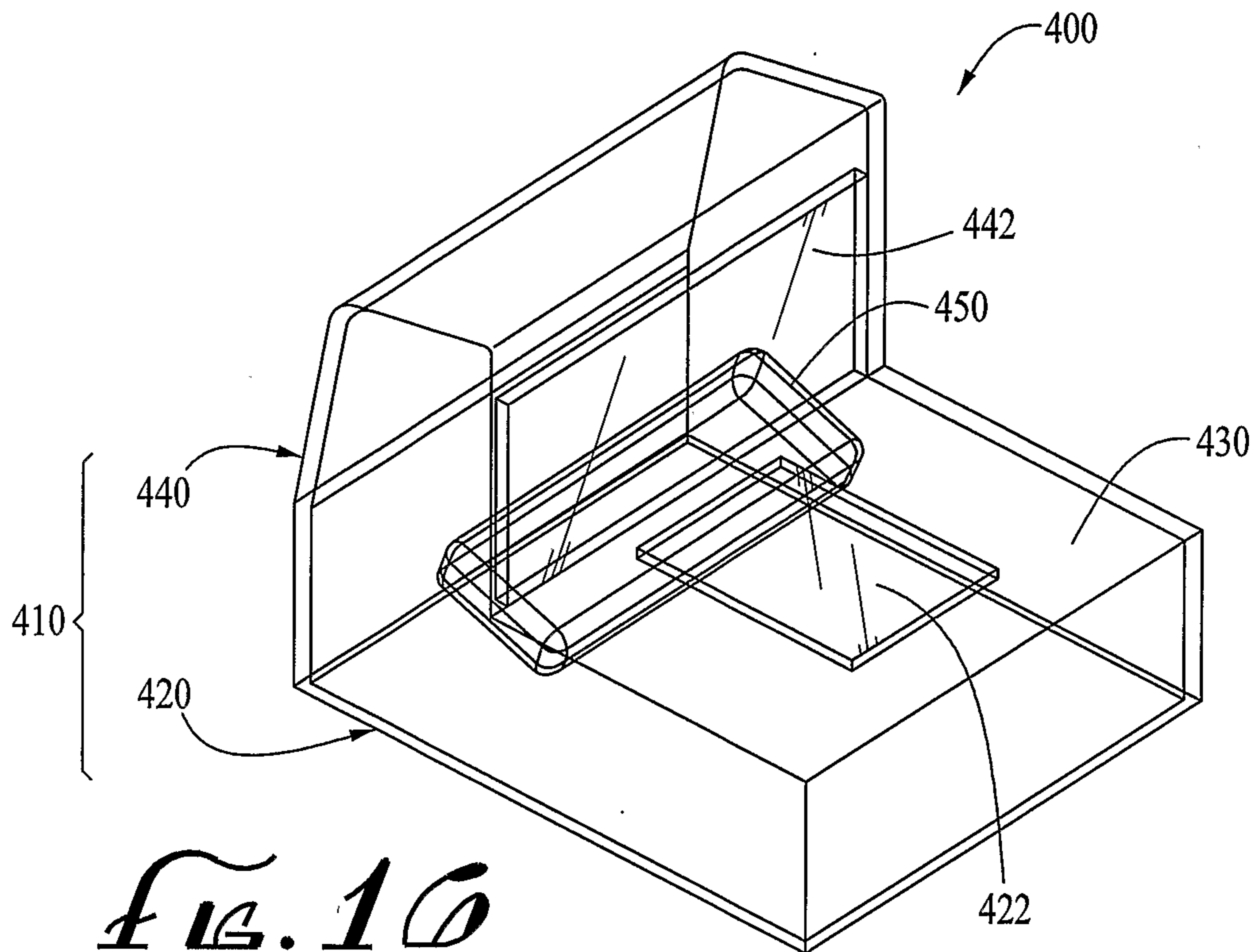
*Fig. 12*

*FIG. 13*

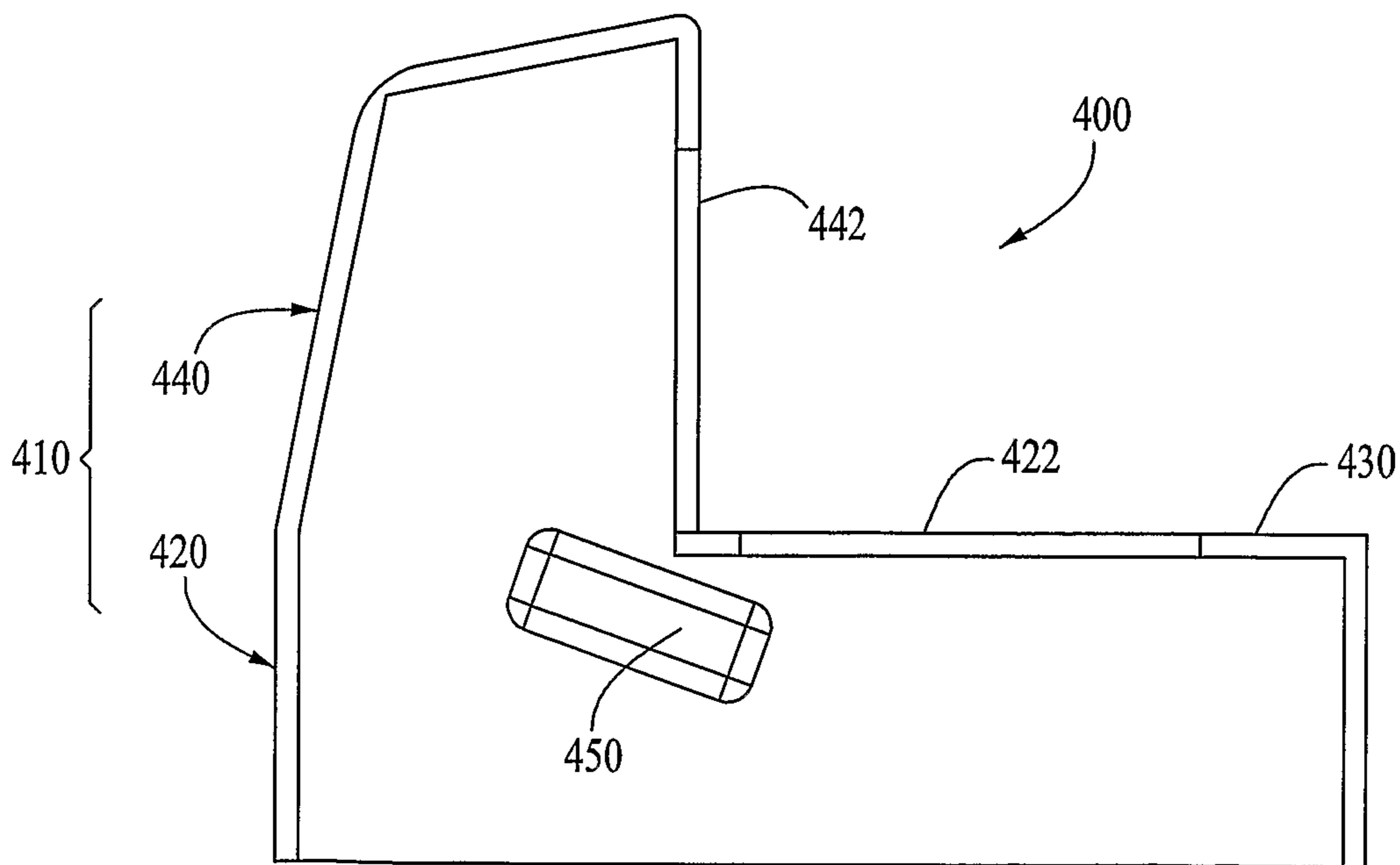




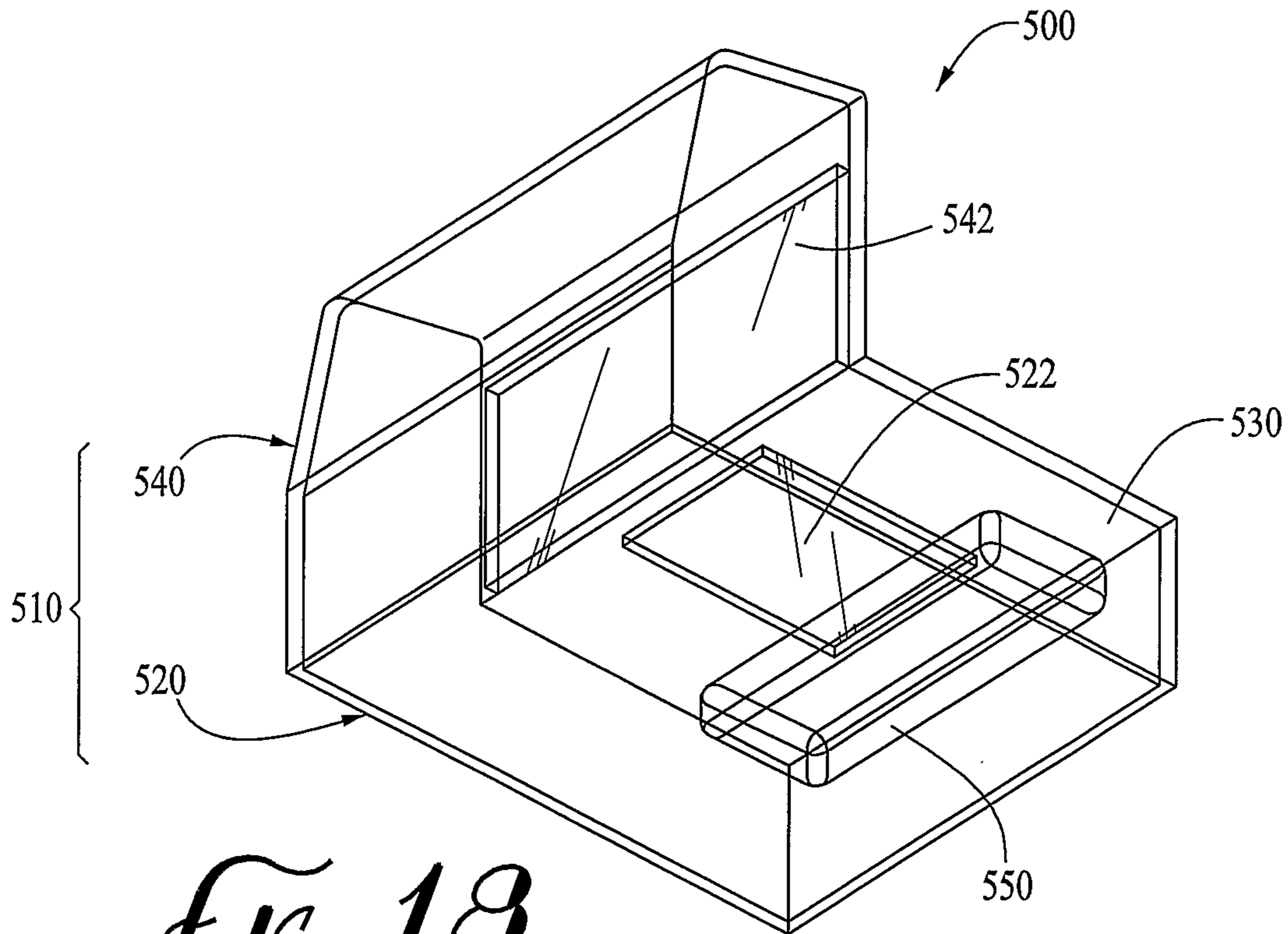
9/13



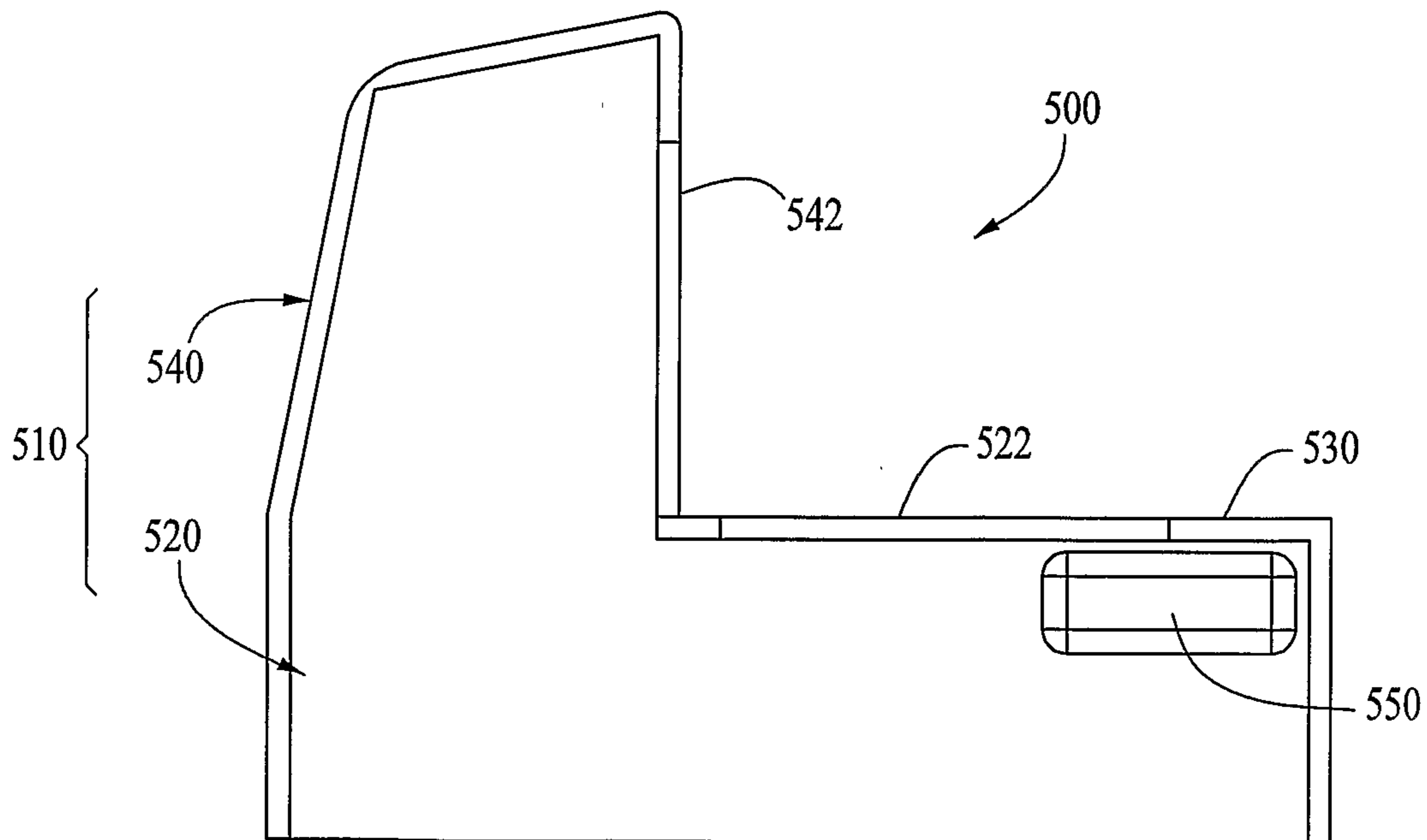
*FIG. 10*



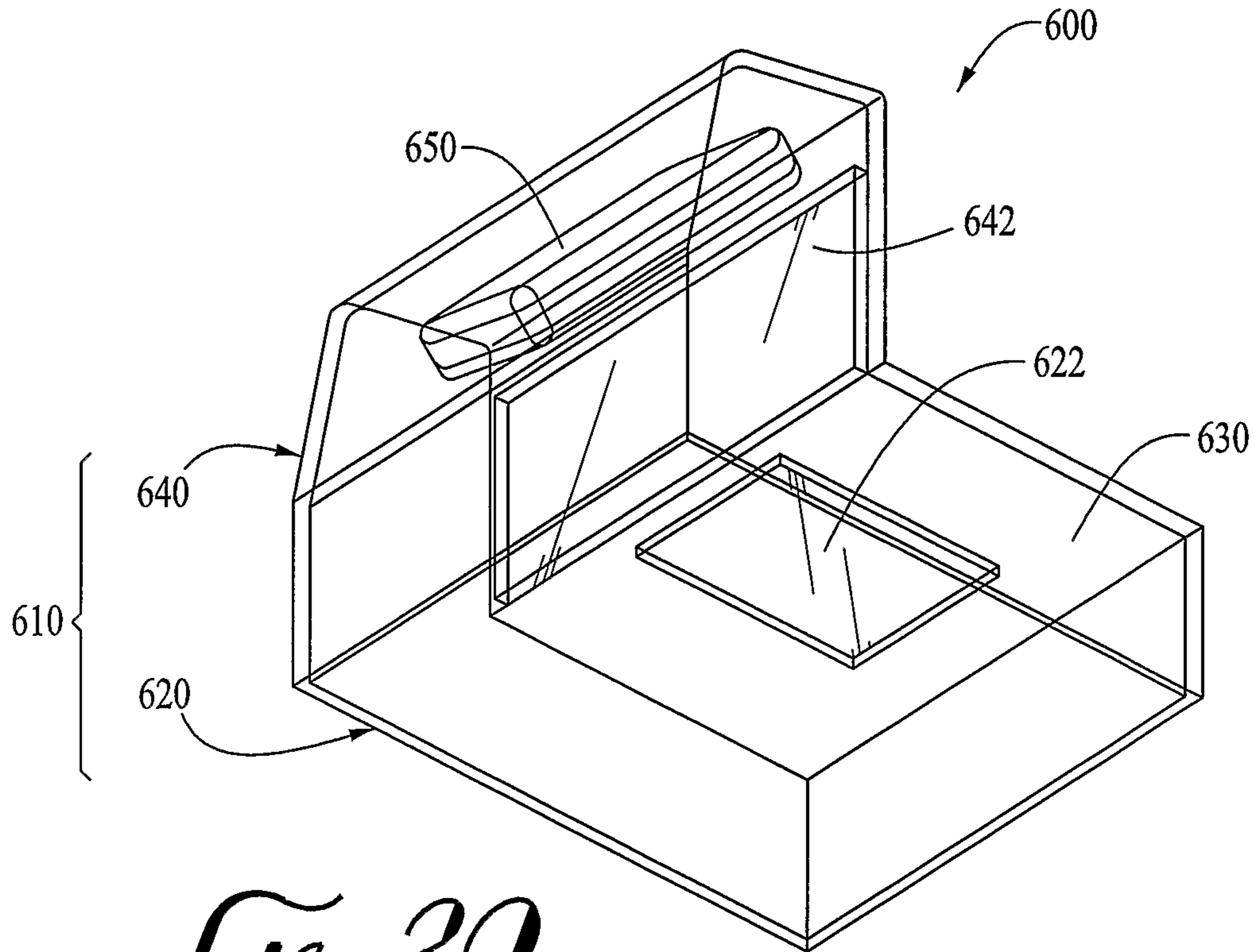
*FIG. 17*



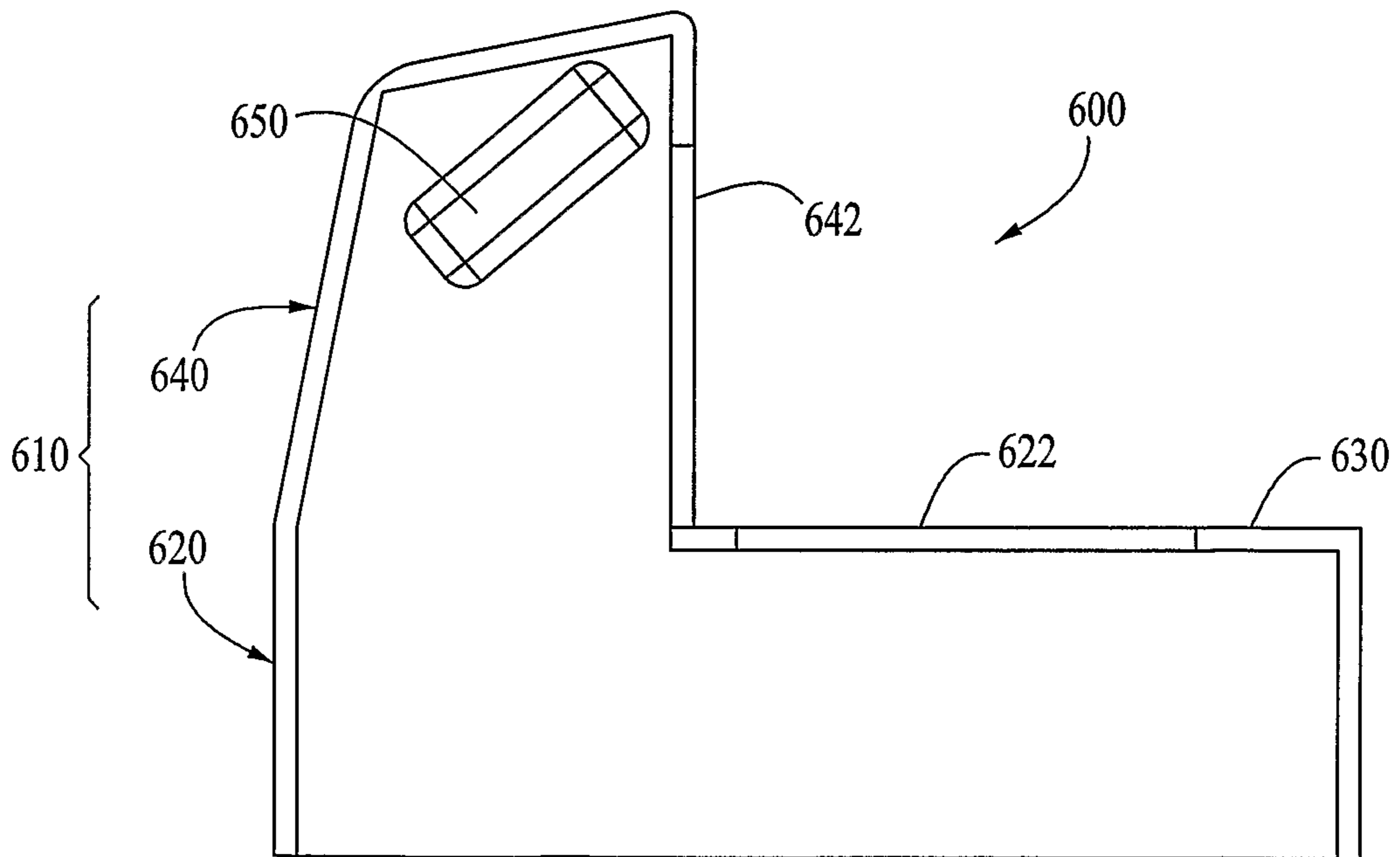
*FIG. 18*



*FIG. 19*

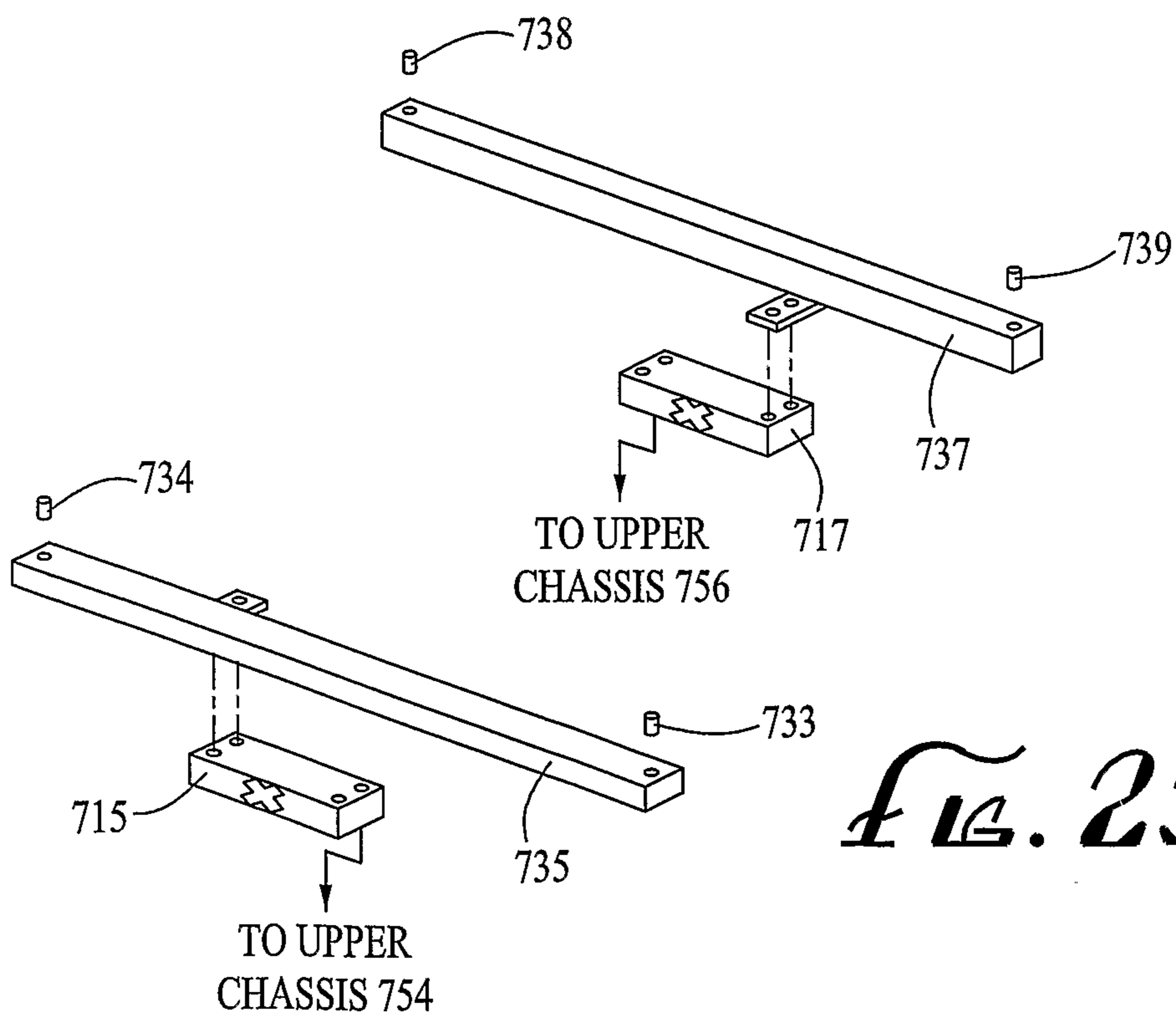
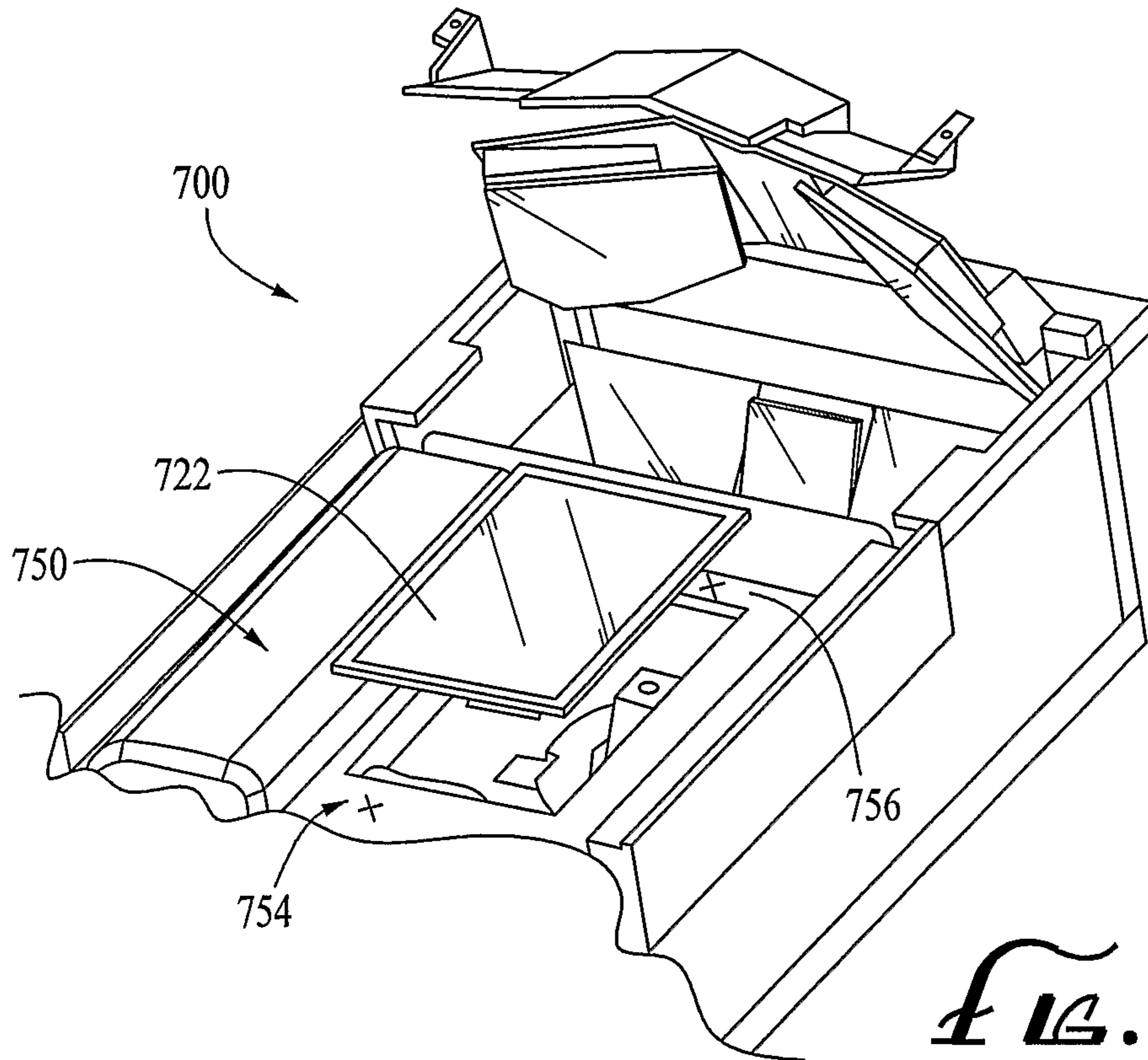


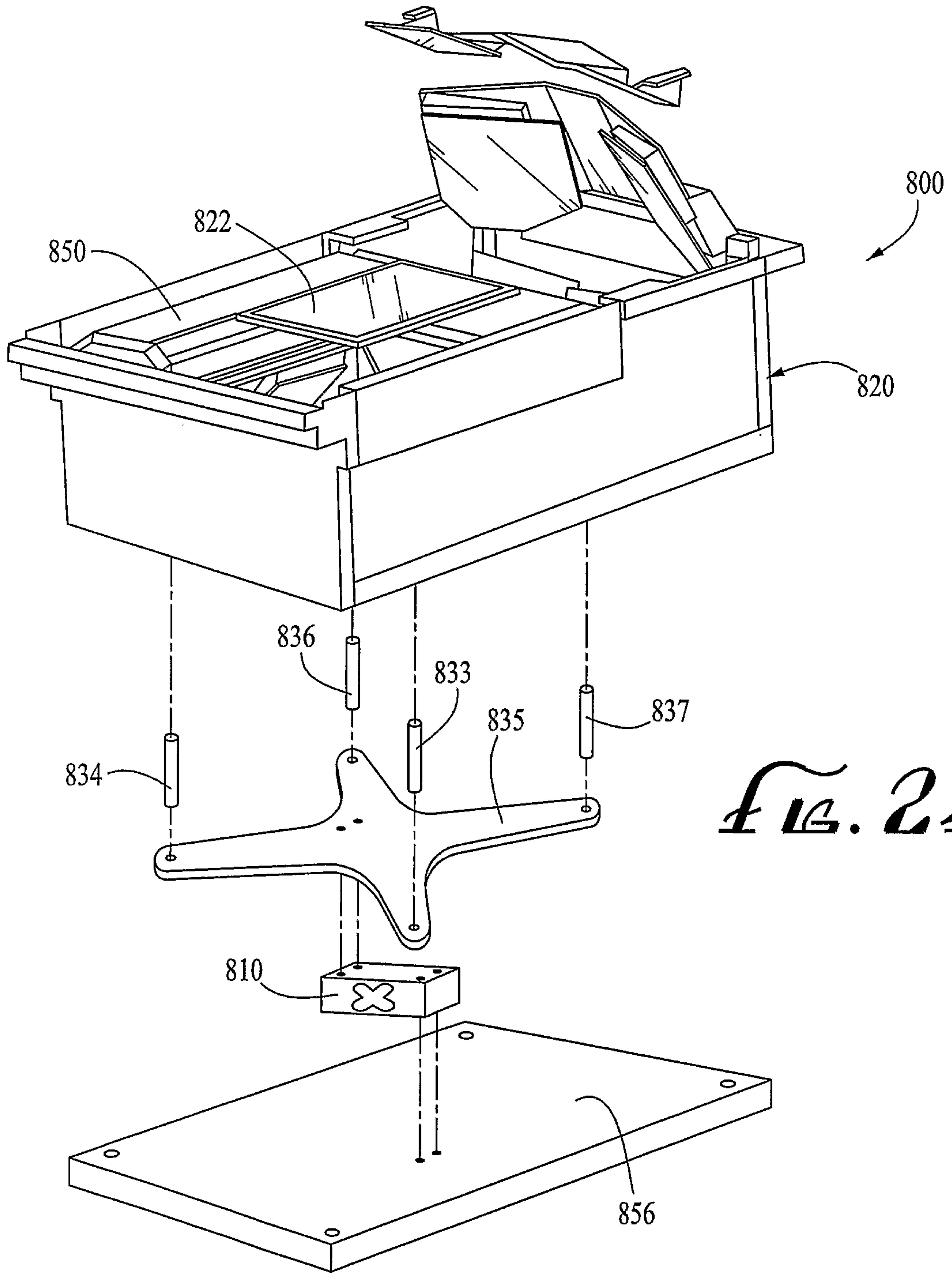
*FIG. 20*



*FIG. 21*







*FIG. 24*

