

(19) World Intellectual Property Organization  
International Bureau



(43) International Publication Date  
6 October 2005 (06.10.2005)

PCT

(10) International Publication Number  
WO 2005/092422 A1

(51) International Patent Classification<sup>7</sup>: A61M 25/01, 25/00

PH, PL, PT, RO, RU, SC, SD, SE, SG, SK, SL, SM, SY, TJ, TM, TN, TR, TT, TZ, UA, UG, US, UZ, VC, VN, YU, ZA, ZM, ZW.

(21) International Application Number: PCT/IE2005/000031

(84) Designated States (unless otherwise indicated, for every kind of regional protection available): ARIPO (BW, GH, GM, KE, LS, MW, MZ, NA, SD, SL, SZ, TZ, UG, ZM, ZW), Eurasian (AM, AZ, BY, KG, KZ, MD, RU, TJ, TM), European (AT, BE, BG, CH, CY, CZ, DE, DK, EE, ES, FI, FR, GB, GR, HU, IE, IS, IT, LT, LU, MC, NL, PL, PT, RO, SE, SI, SK, TR), OAPI (BF, BJ, CF, CG, CI, CM, GA, GN, GQ, GW, ML, MR, NE, SN, TD, TG).

(22) International Filing Date: 24 March 2005 (24.03.2005)

(25) Filing Language: English

(26) Publication Language: English

(30) Priority Data: S2004/0201 26 March 2004 (26.03.2004) IE

**Declaration under Rule 4.17:**

— as to applicant's entitlement to apply for and be granted a patent (Rule 4.17(ii)) for the following designations AE, AG, AL, AM, AT, AU, AZ, BA, BB, BG, BR, BW, BY, BZ, CA, CH, CN, CO, CR, CU, CZ, DE, DK, DM, DZ, EC, EE, EG, ES, FI, GB, GD, GE, GH, GM, HR, HU, ID, IL, IN, IS, JP, KE, KG, KP, KR, KZ, LC, LK, LR, LS, LT, LU, LV, MA, MD, MG, MK, MN, MW, MX, MZ, NA, NI, NO, NZ, OM, PG, PH, PL, PT, RO, RU, SC, SD, SE, SG, SK, SL, SM, SY, TJ, TM, TN, TR, TT, TZ, UA, UG, UZ, VC, VN, YU, ZA, ZM, ZW, ARIPO patent (BW, GH, GM, KE, LS, MW, MZ, NA, SD, SL, SZ, TZ, UG, ZM, ZW), Eurasian patent (AM, AZ, BY, KG, KZ, MD, RU, TJ, TM), European patent (AT, BE, BG, CH, CY, CZ, DE, DK, EE, ES, FI, FR, GB, GR, HU, IE, IS, IT, LT, LU, MC, NL, PL, PT, RO, SE, SI, SK, TR), OAPI patent (BF, BJ, CF, CG, CI, CM, GA, GN, GQ, GW, ML, MR, NE, SN, TD, TG)

(71) Applicant (for all designated States except US): BRIVANT RESEARCH & DEVELOPMENT LIMITED [IE/IE]; Unit 4, Westlink Commercial Park, Oranmore, Galway (IE).

(72) Inventors; and

(75) Inventors/Applicants (for US only): LUPTON, Henry, William [IE/IE]; Minehill House, Renville West, Oranmore, County Galway (IE). BRUZZI, Mark [IE/IE]; Shantalla Place, Galway (IE).

(74) Agent: F.F. GORMAN & CO.; 15 Clanwilliam Square, Dublin 2 (IE).

**Published:**

— with international search report

For two-letter codes and other abbreviations, refer to the "Guidance Notes on Codes and Abbreviations" appearing at the beginning of each regular issue of the PCT Gazette.

(54) Title: A GUIDE WIRE FOR USE IN RE-CANALISING A VASCULAR OCCLUSION IN A HUMAN OR ANIMAL SUBJECT

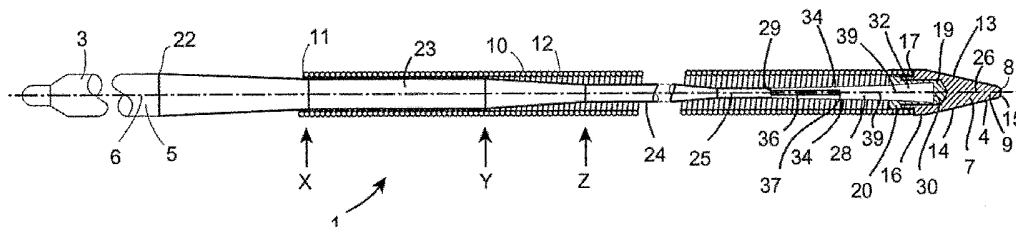

(57) Abstract: A guide wire (1) for re-canalising a vascular occlusion comprises a core wire (5) which terminates at its distal end (4) in a terminal member (7) for opening the occlusion. A helical coil sleeve (10) extends around the core wire (5) from the terminal member (7) to a location (11) along the core wire (5). The terminal member (7) defines first and second planar surface portions (13, 14) which converge towards a distal transversely extending leading edge portion (8). As the terminal member (7) is urged through the vascular occlusion, the first and second surface portions (13, 14) act on the occlusion to form an opening therethrough. A distal portion (28) of the core wire (5) is of spade-like configuration for facilitating bending thereof for directing the terminal member (7) out of a central major plane (35) defined by the distal portion (28) for facilitating aligning of the terminal member (7) with a branched vessel of the vascular system.

WO 2005/092422 A1

“A guide wire for use in re-canalising a vascular occlusion  
in a human or animal subject”

The present invention relates to a guide wire for use in a re-canalising process of a  
5 vascular occlusion in a human or animal subject, and in particular, for re-canalising a  
blocked or partially blocked artery, for example, in the cardiovascular system,  
although the invention is not limited to a guide wire for such use. The invention also  
relates to a method for re-canalising a vascular occlusion in a human or animal  
subject.

10

Guide wires are commonly used for guiding a catheter carrying a therapeutic or  
other device to a remote location in the vascular system of a subject. For example,  
where a vessel is occluded or partially occluded, a guide wire is used for guiding a  
catheter which may carry a balloon or a stent at its distal tip for locating in the artery  
15 in the occluded part thereof for maintaining a passage through the occlusion.  
However, prior to the insertion of the stent or other such device, the occlusion must  
be penetrated in order to open a passage therethrough for accommodating the stent.

20 Guide wires are provided for penetrating such occlusions or partial occlusions prior  
to the insertion of the catheter over the guide wire. U.S. Patent Specification No.  
6,348,040 of Stalker, et al discloses such a catheter which is provided with a  
vibrating tip. However, a disadvantage of the guide wire disclosed in this U.S.  
Patent specification is that in order to provide the vibrating tip, relatively expensive  
and, more importantly, cumbersome equipment is required, which must be attached  
25 to the guide wire.

U.S. Patent Specification No. 6,669,652 of Anderson, et al discloses a guide wire,  
which comprises a core wire and a helical coil extending around a distal portion of  
the core wire. The helical coil extends beyond the distal end of the core wire, and  
30 tapers to a distal point for penetrating the occlusion as the guide wire is urged  
forwardly. One disadvantage of the guide wire disclosed in this U.S. specification is  
that due to the fact that the tip is pointed, there is a danger of the tip penetrating the

wall of a vessel of the vascular system as the guide wire is being urged to the occlusion. Another disadvantage of this guide wire is that the portion of the helical coil which extends beyond the distal end of the core wire is relatively flaccid, and thus renders the guide wire difficult to guide through the vascular system, and in particular a vascular system with branched vessels.

U.S. Patent Specifications Nos. 5,527,298 and 5,127,917 disclose guide wires in which the distal end of the guide wires terminate in bulbous distal tip portions. The distal tip portions are of transverse cross-sectional area significantly greater than the transverse cross-sectional area of the guide wire, and taper to a distal point. The distal point facilitates penetration of the occlusion, and the tapering portion facilitates in easing the guide wire through the occlusion. However, a disadvantage of the guide wires disclosed in these two U.S. Patent specifications is that due to the fact that the transverse cross-sectional area of the bulbous distal tip portions are significantly greater than the transverse cross-sectional area of the guide wire, difficulty is experienced in subsequently urging a catheter over the bulbous tip portions.

There is therefore a need for a guide wire which is suitable for use in a re-canalising process of a vascular occlusion in a human or animal subject.

The present invention is directed towards providing such a guide wire, and the invention is also directed towards providing a method for re-canalising a vascular occlusion in a human or animal subject.

According to the invention there is provided a guide wire for use in a re-canalising process for re-canalising a vascular occlusion in a human or animal subject, the guide wire extending between a proximal end and a distal end, and defining a longitudinally extending main central axis, wherein the guide wire terminates at its distal end in a terminal member extending axially from the guide wire, the terminal member tapering to a distal leading tip portion for engaging and gradually opening the occlusion as the terminal member is urged therethrough.

Preferably, the leading edge portion is an elongated leading edge portion.  
Advantageously, the leading edge portion extends in a direction at an angle relative to an axial direction defined by the main central axis.

5

In one embodiment of the invention the leading edge portion extends in a direction at an angle in the range of 1° to 90° relative to an axial direction defined by the main central axis. Preferably, the leading edge portion extends in a direction at an angle in the range of 45° to 90° relative to an axial direction defined by the main central axis. Advantageously, the leading edge portion extends in a direction at an angle of approximately 60° relative to an axial direction defined by the main central axis.

10

In one embodiment of the invention the leading edge portion extends in a direction substantially transversely of the main central axis.

15

In one embodiment of the invention a first surface portion of the terminal member converges towards an opposite second surface portion thereof towards the leading edge portion.

20

In another embodiment of the invention the first surface portion of the terminal member is planar.

In a further embodiment of the invention the first surface portion of the terminal member is convex in a longitudinal direction relative to the main central axis.

25

In a still further embodiment of the invention the first surface portion of the terminal member is concave in a longitudinal direction relative to the main central axis.

30

In a still further embodiment of the invention the first surface portion of the terminal member is sequentially convex and concave in a longitudinal direction relative to the main central axis.

In one embodiment of the invention a distal portion of the first surface portion of the terminal member is concave in a longitudinal direction relative to the main central axis.

- 5 In another embodiment of the invention a proximal portion of the first surface portion of the terminal member is convex in a longitudinal direction relative to the main central axis.

10 In another embodiment of the invention the first surface portion of the terminal member is convex in a transverse direction relative to the main central axis.

In a further embodiment of the invention the second surface portion of the terminal member converges towards the first surface portion towards the leading edge portion.

15

In one embodiment of the invention the second surface portion of the terminal member is planar.

20 In another embodiment of the invention the second surface portion of the terminal member is convex in a longitudinal direction relative to the main central axis.

In a further embodiment of the invention the second surface portion of the terminal member is concave in a longitudinal direction relative to the main central axis.

25 In a still further embodiment of the invention the second surface portion of the terminal member is sequentially convex and concave in a longitudinal direction relative to the main central axis.

30 In a still further embodiment of the invention a distal portion of the second surface portion of the terminal member is concave.

In a further embodiment of the invention a proximal portion of the second surface

portion of the terminal member is convex.

In one embodiment of the invention the second surface portion of the terminal member is convex in a transverse direction relative to the main central axis.

5

Preferably, the first and second surface portions terminate in the leading edge portion to define the leading edge portion as a chisel edge.

In one embodiment of the invention the first and second surface portions of the terminal member define an included angle in the range of  $1^\circ$  to  $179^\circ$ . Preferably, the first and second surface portions of the terminal member define an included angle in the range of  $5^\circ$  to  $90^\circ$ . Advantageously, the first and second surface portions of the terminal member define an included angle of approximately  $15^\circ$ .

15 In one embodiment of the invention the first and second surface portions of the terminal member are joined by spaced apart opposite third and fourth surface portions. Preferably, the leading edge portion of the terminal member extends between the third and fourth surface portions.

20 In one embodiment of the invention the third and fourth surface portions of the terminal member are planar surfaces. In an alternative embodiment of the invention the third and fourth surface portions of the terminal member are convex in a transverse direction relative to the main central axis.

25 In another embodiment of the invention the third and fourth surface portions of the terminal member are parallel to each other in an axial direction defined by the main central axis.

30 Alternatively, the third and fourth surface portions of the terminal member taper towards the leading edge portion.

In one embodiment of the invention the third and fourth surface portions of the

terminal member define an included angle in the range of 1° to 179°. Preferably, the third and fourth surface portions of the terminal member define an included angle in the range of 5° to 90°. Advantageously, the third and fourth surface portions of the terminal member define an included angle of approximately 15°.

5

In one embodiment of the invention the third surface portion of the terminal member is convex in a longitudinal direction relative to the main central axis. Alternatively, the third surface portion of the terminal member is concave in a longitudinal direction relative to the main central axis.

10

In another embodiment of the invention the third surface portion of the terminal member is sequentially convex and concave in a longitudinal direction relative to the main central axis.

15

In a still further embodiment of the invention a distal portion of the third surface portion of the terminal member is concave in a longitudinal direction relative to the main central axis, and in a further embodiment of the invention a proximal portion of the third surface portion of the terminal member is convex in a longitudinal direction relative to the main central axis.

20

In one embodiment of the invention the fourth surface portion of the terminal member is convex in a longitudinal direction relative to the main central axis. Alternatively, the fourth surface portion of the terminal member is concave in a longitudinal direction relative to the main central axis.

25

In one embodiment of the invention the fourth surface portion of the terminal member is sequentially convex and concave in a longitudinal direction relative to the main central axis. In a further embodiment of the invention a distal portion of the fourth surface portion of the terminal member is concave in a longitudinal direction

30

relative to the main central axis, and in a still further embodiment of the invention a proximal portion of the fourth surface portion of the terminal member is convex in a longitudinal direction relative to the main central axis.

Preferably, the leading edge portion is radiused from the first surface portion of the terminal member to the second surface portion thereof. Advantageously, the leading edge portion is radiused in plan view.

5

In another embodiment of the invention the leading edge portion is convex in plan view. Alternatively, the leading edge portion is concave in plan view.

In one embodiment of the invention the maximum outer transverse cross-sectional area of the terminal member is substantially similar to the outer transverse cross-sectional area of the guide wire adjacent the terminal member. Preferably, the outer transverse cross-sectional area of the terminal member adjacent the guide wire is similar to the outer transverse cross-sectional area of the guide wire adjacent the terminal member so that the outer surface of the terminal member is in axial alignment with the outer surface of the guide wire adjacent the terminal member. Advantageously, the guide wire adjacent the terminal member and the terminal member adjacent the guide wire are of circular transverse cross-section, and are of substantially similar outer diameters.

Advantageously, the transverse width of the leading edge portion is substantially similar to the transverse width of the guide wire adjacent the terminal member in a plane containing the leading edge portion and extending parallel to the main central axis.

In one embodiment of the invention the guide wire comprises an elongated core wire extending from the proximal end to the distal end. Preferably, the terminal member is secured to the distal end of the core wire.

Advantageously, the core wire terminates in a distal portion of rectangular transverse cross-section defining first and second opposite major surfaces joined by first and second opposite minor surfaces for facilitating bending thereof for offsetting the terminal member relative to the main central axis for facilitating guiding of the

terminal member into a branched vessel of a vascular system.

In one embodiment of the invention the first and second major surfaces of the distal portion of the core wire converge towards each other towards the distal end thereof.

5 Alternatively, the first and second major surfaces of the distal portion of the core wire extend substantially parallel to each other.

In another embodiment of the invention the first and second minor surfaces of the distal portion of the core wire diverge from each other towards the distal end thereof.

10 Alternatively, the first and second minor surfaces of the distal portion of the core wire extend substantially parallel to each other.

In one embodiment of the invention a reinforcing means is provided on the distal portion of the core wire for minimising axial twisting thereof.

15

In another embodiment of the invention the first and second major surfaces of the distal portion of the core wire define therebetween a central major plane extending parallel to the main central axis and cutting the first and second minor surfaces, and the distal portion is curved in the central major plane for offsetting the terminal member relative to the main central axis for in turn facilitating guiding of the terminal member into a branched vessel of a vascular system.

20

Preferably, the central major plane defined by the first and second major surfaces of the distal portion of the core wire extends transversely of a plane containing the leading edge portion of the terminal member and extending parallel to the main central axis.

25

Advantageously, the central major plane defined by the first and second major surfaces of the distal portion of the core wire extends substantially parallel to a plane containing the leading edge portion of the terminal member and extending parallel to the main central axis.

30

In one embodiment of the invention the core wire extending from the distal portion thereof to the proximal end is of circular transverse cross-section.

In another embodiment of the invention a sleeve extends along the core wire from the terminal member and terminates at a location intermediate the distal end and the proximal end of the core wire. Preferably, the sleeve is of external circular transverse cross-section. Advantageously, the external diameter of the sleeve is substantially similar to the diameter of the terminal member adjacent the guide wire. Ideally, the sleeve comprises a helical coil located around the core wire adjacent the distal end thereof.

In one embodiment of the invention a plug extends from the terminal member adjacent a proximal end thereof for engaging an internal bore defined by the sleeve for securing the sleeve to the terminal member.

Preferably, the terminal member is secured to the sleeve by brazing or soldering.

Advantageously, a core wire engaging bore extends into the terminal member for engaging the distal end of the core wire.

Preferably, the core wire engaging bore extends axially into the terminal member.

Advantageously, the terminal member is secured to the core wire by brazing, soldering, welding or adhesive. Ideally, the soldering or brazing, soldering, welding or adhesive material is a radiopaque material.

In one embodiment of the invention the terminal member is of radiopaque material.

In another embodiment of the invention at least a portion of the terminal member is of a magnetic material for facilitating urging of the terminal member through a vascular system by a magnetic urging means located externally of the subject.

In a further embodiment of the invention the terminal member is of a magnetic material.

5 In one embodiment of the invention a distal portion of the guide wire is of a magnetic material for facilitating urging of the terminal member through a vascular system by a magnetic urging means located externally of the subject.

10 The invention also provides in combination the guide wire according to the invention and a magnetic urging means for urging the terminal member through a vascular occlusion.

Preferably, the magnetic urging means for urging the terminal member through a vascular system to a vascular occlusion.

15 The invention also provides a method for re-canalising a vascular occlusion in a human or animal subject, the method comprising urging the terminal member of the guide wire according to the invention through the occlusion for gradually opening thereof.

20 Preferably, the terminal member is urged by the guide wire through a vascular system to the occlusion prior to being urged through the occlusion.

Advantageously, the terminal member is urged through the occlusion by a magnetic urging means located externally of the subject.

25 Ideally, the terminal member is urged through a vascular system by a magnetic urging means located externally of the subject.

30 The advantages of the invention are many. The guide wire according to the invention is particularly suitable for use in re-canalising a vascular occlusion in a vascular system in a human or animal body, and in particular, for use re-canalising an occluded or partially occluded vessel in the cardiovascular system of the human

or animal body. By virtue of the fact that the terminal member tapers to a distal leading edge portion, the distal leading edge portion initially engages the vascular occlusion, and as the terminal member is urged through the vascular occlusion, the tapering portion of the terminal member gradually opens the occlusion, until the  
5 terminal member opens the occlusion to define a bore of transverse cross-section corresponding to the maximum external transverse cross-sectional area of the terminal member.

By providing the terminal member to be of transverse cross-sectional area  
10 substantially similar to that of the guide wire, so that the outer surface of the terminal member is aligned with and substantially coincides with the outer surface of the guide wire, a catheter can be readily easily passed over the guide wire and over the terminal member, without snagging on the terminal member.

15 A particular advantage is achieved when the terminal member terminates in a transversely extending distal leading edge portion. The transversely extending leading edge portion facilitates ease of penetration of the vascular occlusion, and subsequent gradual opening of the vascular occlusion as the transversely extending leading edge portion is urged through the occlusion. By providing the terminal  
20 member with respective opposite first and second surface portions which converge towards each other towards the distal leading tip portion, a particularly advantageous form of the terminal member is obtained, and the terminal member is particularly suitable for gradually opening the vascular occlusion as the terminal member is urged therethrough. By providing the first and second converging surface portions  
25 as planar surface portions, a further advantage is achieved in that the rate of penetration of the occlusion can be maintained relatively constant through the constant increase in surface contact. Tapering the third and fourth surface portions of the terminal member further enhances this advantage.

30 The provision of the terminal member with a first surface portion which is either convex or concave, or is sequentially convex and concave from the proximal to the distal end thereof, provides a gradual transition from the tapering portion of the

terminal member to the guide wire.

By providing the terminal member of a magnetic material, the terminal member can be urged through the vascular system by a magnetic field generated by a suitable magnetic urging device located externally of the subject. This has the added advantage that the terminal member can be urged through the vascular system by the magnetic field, rather than by pushing the guide wire into the subject. By being able to urge the terminal member through the vascular system by an externally generated magnetic field in particular facilitates in directing the terminal member into a branched vessel of a vascular system, without the need to pre-bend the guide wire. Additionally, by urging the terminal member by an externally generated magnetic field, the risk of puncturing a vessel of the vascular system as the terminal member is being urged therethrough is minimised.

Additionally, since it is important that the guide wire remain flexible in order to negotiate the tortuous vascular systems of the anatomy, by magnetically pulling the guide wire through the vascular system, the guide wire can be provided to be considerably more flexible than would be the case where the guide wire is being provided to be pushed through the vascular system. The more flexible a guide wire is, the less easy it is to guide it through the vascular system by pushing. Thus, in order to facilitate relatively accurate guiding of a guide wire through the vascular system which is to be pushed through the vascular system, the guide wire must be of lesser flexibility than where the guide wire is being pulled through the vascular system. Additionally, by providing the guide wire to be magnetically pulled through the vascular system, there is a lesser risk of the terminal member entering a false lumen between the laminae of a vessel.

The invention will be more clearly understood from the following description of some preferred embodiments thereof, which are given by way of example only, with reference to the accompanying drawings, in which:

Fig. 1 is a side elevational view of a guide wire according to the invention,

Fig. 2 is a perspective view of a portion of the guide wire of Fig. 1,

Fig. 3 is another perspective view of the portion of Fig. 2 of the guide wire of  
5 Fig. 1,

Fig. 4 is a transverse cross-sectional side elevational view of the guide wire  
of Fig. 1,

10 Fig. 5 is a partly transverse cross-sectional side elevational view of a portion  
of the guide wire of Fig. 1,

Fig. 6 is a partly transverse cross-sectional plan view of the portion of Fig. 5,  
on the line VI-VI of Fig. 5 of the guide wire of Fig. 1,

15 Fig. 7 is a transverse cross-sectional side elevational view of a portion of the  
guide wire of Fig. 1,

20 Fig. 8 is an end elevational view of the portion of Fig. 7 of the guide wire of  
Fig. 1,

Fig. 9 is a side elevational view of another portion of the guide wire of Fig. 1,

25 Fig. 10 is a transverse cross-sectional side elevational view of a portion of the  
guide wire of Fig. 1 with a portion of the guide wire curved,

Fig. 11 is a transverse cross-sectional side elevational view similar to Fig. 7  
of a detail similar to that of Fig. 7 of a guide wire according to another  
embodiment of the invention,

30 Fig. 12 is a transverse cross-sectional side elevational view similar to Fig. 7  
of a detail similar to that of Fig. 7 of a guide wire according to another

embodiment of the invention,

Fig. 13 is a perspective view of a portion of a guide wire according to another embodiment of the invention,

5

Fig. 14 is a perspective view of a portion of a guide wire according to a further embodiment of the invention,

10

Fig. 15 is a perspective view of a portion of a guide wire according to a still further embodiment of the invention,

Fig. 16 is a perspective view of a portion of a guide wire according to a further embodiment of the invention,

15

Fig. 17 is an end elevational view of the portion of the guide wire of Fig. 16,

Fig. 18 is a perspective view of a part of the portion of the guide wire of Fig. 16,

20

Fig. 19 is a side elevational view of a portion of a guide wire according to a still further embodiment of the invention,

Fig. 20 is a top plan view of the portion of the guide wire of Fig. 19,

25

Fig. 21 is an end view of the portion of the guide wire of Fig. 19,

Fig. 22 is a top plan view of a portion of a guide wire according to another embodiment of the invention,

30

Fig. 23 is an end elevational view of the portion of the guide wire of Fig. 22,

Fig. 24 is a top plan view of a portion of a guide wire according to a further

embodiment of the invention,

Fig. 25 is an end elevational view of the portion of the guide wire of Fig. 24,

5 Fig. 26 is a top plan view of a portion of a guide wire according to another embodiment of the invention,

Fig. 27 is an end elevational view of the portion of the guide wire of Fig. 26,

10 Fig. 28 is a top plan view of a portion of a guide wire according to another embodiment of the invention,

Fig. 29 is an end elevational view of the portion of the guide wire of Fig. 28,

15 Fig. 30 is a perspective view of the portion of the guide wire of Fig. 28,

Fig. 31 is a perspective view of a portion of a guide wire according to another embodiment of the invention,

20 Fig. 32 is a perspective view of a part of the portion of the guide wire of Fig. 31,

Fig. 33 is a perspective view of a portion of a guide wire according to another embodiment of the invention,

25 Fig. 34 is a perspective view of a part of the portion of the guide wire of Fig. 33,

30 Fig. 35 is a perspective view of a portion of a guide wire according to a further embodiment of the invention,

Fig. 36 is a perspective view of a portion of a guide wire according to a still

further embodiment of the invention,

Fig. 37 is an end elevational view of the portion of the guide wire of Fig. 36,

5 Fig. 38 is a side elevational view of a portion of a guide wire according to a still further embodiment of the invention, and

Fig. 39 is a top plan view of the portion of the guide wire of Fig. 38.

10 Referring to the drawings and initially to Figs. 1 to 10, there is illustrated a guide wire according to the invention, indicated generally by the reference numeral 1, for use in a re-canalising process for re-canalising a vascular occlusion in a vascular system of a human or animal subject. The guide wire 1 extends between a proximal end 3 and a distal end 4 and comprises a core wire 5 of circular transverse cross-section and of  
15 stainless steel material which extends from the proximal end 3 to the distal end 4, and defines a longitudinally extending main central axis 6. A terminal member 7 of circular transverse cross-section adjacent its proximal end portion 16 defines a central axis 9, and is secured to the core wire 5 at its distal end 4, and extends axially therefrom with the central axis 9 of the terminal member 7 coinciding with the  
20 main central axis 6 of the core wire 5. The terminal member 7 tapers to a distal leading edge portion, which in this embodiment of the invention is a transversely extending elongated leading edge portion 8 in the form of a chisel edge for engaging and penetrating the occlusion or partial occlusion in a vessel of the vascular system as the guide wire 1 is urged through the vascular system. The leading edge portion  
25 8 extends at 90° to the main central axis 6. A sleeve, in this embodiment of the invention provided by a tightly wound helical coil 10 of stainless steel material is secured to the terminal member 7 at the proximal end portion 16 thereof, and extends therefrom over the core wire 5, and terminates at a location 11 intermediate the proximal end 3 and the distal end 4 of the guide wire 1, but towards the distal  
30 end 4. The helical coil 10 is of circular transverse cross-section, and defines a bore 12 of circular transverse cross-section.

The terminal member 7 is of radiopaque material, in this embodiment of the invention platinum alloy, so that it is visible under X-rays as the guide wire 1 is being urged through the vascular system. The outer diameter of the terminal member 7 at its proximal end portion 16 is constant and is substantially similar to the outer diameter of the helical coil 10 adjacent the terminal member 7 so that as a catheter is being urged along the guide wire 1, the catheter can readily easily be urged over the terminal member 7. The terminal member 7 defines a first surface portion 13 and a second surface portion 14 which converge towards each other and terminate in the leading edge portion 8. In this embodiment of the invention the first and second surface portions 13 and 14 are planar, and the leading edge portion 8 is radiused, with a radius  $r$ , between the first and second surface portions 13 and 14 to form the leading edge portion 8 to be convex in a plane perpendicular to a plane containing the leading edge portion 8. The radius  $r$  of the convex surface 15 of the leading edge portion 8 is sufficiently large to provide the leading edge portion 8 to be sufficiently blunt to prevent the leading edge portion 8 penetrating a wall of a vessel of the vascular system, but not so blunt as would prevent the leading edge portion 8 penetrating an occlusion or a partial occlusion in a vessel of the vascular system. The first and second surface portions 13 and 14 define an included angle  $\alpha$ , see Fig. 7, which is sufficiently acute for gradually opening the occlusion as the terminal member 7 is urged therethrough, while at the same time avoiding detaching any of the occluding material from the vessel, in order to avoid urging the occluding material forwardly with the guide wire 1. The first and second surface portions 13 and 14 are joined by third and fourth surface portions 18 and 21, respectively, which extend from the proximal end portion 16 of the terminal member 7 to the leading edge portion 8. The third and fourth surface portions 18 and 21 are radiused, and are of the same radius as the outer surface of the proximal end portion 16, and thus, coincide with the outer surface of the proximal end portion 16, and are convex in a transverse direction relative to the main central axis 6.

The first and second surface portions 13 and 14 define a central major plane 26 which bisects the included angle  $\alpha$  defined by the first and second surface portions 13 and 14. In this embodiment of the invention the central major plane 26 defined by

the first and second surface portions 13 and 14 contains the main central axis 6 and the leading edge portion 8. The transverse width of the leading edge portion 8 is thus similar to the diameter of the proximal end portion 16 of the terminal member 7, and furthermore, the transverse cross-section of the portion of the terminal member  
5 formed by the first and second surface portions 13 and 14 is such as not to extend beyond the outer transverse cross-sectional profile of the circular proximal end portion 16 of the terminal member 7.

In this embodiment of the invention the included angle  $\alpha$  defined by the first and  
10 second surface portions 13 and 14 of the terminal member 7 is approximately  $15^\circ$ , however, it is envisaged that the included angle  $\alpha$  defined by the first and second surface portions 13 and 14 may be any acute angle in the range  $5^\circ$  to  $60^\circ$ , although it is believed that it is preferable that the acute angle  $\alpha$  defined by the first and second surface portions 13 and 14 should lie in the range  $12^\circ$  to  $30^\circ$ . In this  
15 embodiment of the invention the radius  $r$  of the radiused convex surface 15 of the leading edge portion of the terminal member 7 is approximately 0.075mm, although it is envisaged that the radius of the radiused convex surface 15 may lie in the range 0.02mm to 0.14mm, although it is believed that it is preferable that the radius  $r$  should lie within the range 0.05mm to 0.10mm.

20

A plug 17 extends axially from the terminal member 7 for engaging the bore 12 in the helical coil 10 at the distal end thereof. The diameter of the plug 17 is such that the difference between the diameter of the plug 17 and the diameter at the proximal end portion 16 of the terminal member 7 is equal to twice the diameter of the wire  
25 forming the helical coil 10, so that when the plug member 17 is engaged in the bore 12 of the helical coil 10, the outer surface defined by the helical coil 10 substantially coincides with the outer surface of the proximal end portion 16 of the terminal member 7. A bore 19 extends axially into the plug 17 and into the terminal member 7 for accommodating the distal end 4 of the core wire 5 for securing the terminal  
30 member 7 to the core wire 5. In this embodiment of the invention the core wire 5 and the helical coil 10 are soldered to the terminal member 7 by solder 20 which fills the bore 19 as well as a distal portion of the bore 12 of the helical coil 10 for securing

the terminal member 7 to the core wire 5 and the helical coil 10.

The core wire 5 commences to taper at a location 22 at the proximal side of the location 11 at which the helical coil 10 terminates, and tapers to its distal end 4. In this embodiment of the invention the core wire 5 tapers in steps as is illustrated in Fig. 4. The core wire 5 tapers from the location 22 to a first portion 23 of constant diameter, and tapers from the first portion 23 to a second portion 24 of constant diameter, and in turn tapers from the second portion 24 to a third portion 25 of constant diameter. A distal portion 28 extends from the third portion 25 at 29 to a transversely extending distal tip 30, and is of spade-like configuration having a rectangular transverse cross-section. The distal portion 28 defines a first major surface 32 and a second major surface 33, which are joined by opposite minor surfaces 34. The first and second major surfaces 32 and 33 converge towards each other towards the distal tip 30, while the minor surfaces 34 diverge away from each other towards the distal tip 30. The first and second major surfaces 32 and 33 define therebetween a central major plane 35 which contains the transversely extending distal tip 30 and the main central axis 6, and extends perpendicular to the minor surfaces 34. The spade-like configuration of the distal portion 28 facilitates bending of the guide wire at the distal portion 28 for urging the terminal member 7 out of the central major plane 35 for facilitating aligning the guide wire 1 with a branching vessel of the vascular system and directing the terminal member 7, and in turn the guide wire 1 into the branching vessel.

A reinforcing means, in this embodiment of the invention provided by a reinforcing rib 36 extends longitudinally along the first major surface 32 of the distal portion 28 from the location 29, and terminates at a location 37 intermediate the location 29 and the distal tip 30 for minimising torsional twisting of the core wire along the distal portion 28. Where the distal portion 28 is to be bent for bending the terminal member 7 out of the central major plane 35, the distal portion 28 is bent between the location 37 and the terminal member 7.

A portion 38 of the distal portion 28 of the core wire 5 may be curved in the central

major plane 35 as illustrated in Fig. 10 for directing the terminal member 7 out of a central minor plane 39 defined between the minor surfaces 34 and containing the main central axis 6 and extending perpendicularly of the first and second major surfaces 32 and 33. Forming the curved portion 38 in the distal portion 28 also facilitates aligning of the terminal member 7 with a branched vessel of the vascular system, and directing the terminal member 7, and in turn, the guide wire 1 into the branched vessel. When the guide wire 1 is provided with the distal portion 28 curved at 38, the distal portion 28 could still be bent between the location 37 and the terminal member 7 for directing the terminal member 7 out of the central major plane 35. In this way, the terminal member 7 would be directed out of both the major and minor central planes 35 and 39, respectively.

In practice, bending of the distal portion 28 between the location 37 and the terminal member 7 for urging the terminal member 7 out of the central major plane 35 would typically be carried out manually by a surgeon or a paramedic prior to inserting the guide wire 1 into the subject. The curved portion 38 for directing the terminal member 7 out of the central minor plane 39 would normally be factory formed.

The amount by which the curved portion 38 of the distal portion 28 is curved determines the amount by which the terminal member 7 is offset from the central major plane 35, in other words, the amount of curvature in the curved portion 38 determines the included angle  $\theta$  which the central axis 9 of the terminal member 7 makes with the main central axis 6, namely, the angular offset of the terminal member 7 relative to the main central axis 6. In Fig. 10 the angle  $\theta$  is illustrated as being  $90^\circ$ , however, it will be readily apparent to those skilled in the art that the angle  $\theta$  may be any desired angle, and typically will lie between  $0^\circ$  and  $90^\circ$ . The angle at which the portion of the distal portion 28 between the location 37 and the terminal member 7 may be bent may be any desired angle, and typically would be in the range from  $0^\circ$  to  $90^\circ$ .

In this embodiment of the invention the terminal member 7 is secured to the distal portion 28 of the core wire 5 with the central major plane 26 defined by the first and

second surface portions 13 and 14 extending perpendicularly to the central major plane 35 defined by the first and second major surfaces 32 and 33 of the distal portion 28 of the core wire 5. Accordingly, the leading edge portion 8 extends perpendicularly to the central major plane 35 defined by the first and second major surfaces 32 and 33 of the distal portion 28 of the core wire 5. This facilitates bending of the flattened distal portion 28 in the direction of the arrows A and B, see Fig. 6. However, it is envisaged that the terminal member 7 may be secured to the core wire 5 with the central major plane 26 defined between the first and second surface portions 13 and 14 of the terminal member 7 extending parallel to or coinciding with the central major plane 35 defined between the first and second major surfaces 32 and 33 of the distal portion 28 of the core wire 5. In which case the leading edge portion 8 would extend parallel to or coincide with the central major plane 35 defined by the first and second major surfaces 32 and 33 of the distal portion 28 of the core wire 5.

In use, the guide wire 1 is urged through the vascular system of the subject towards the occluded vessel. On reaching the occluded vessel, the guide wire is gradually urged forward and the leading edge portion 8 of the terminal member 7 engages the occlusion and commences penetration thereof. As the leading edge portion 8 penetrates the occlusion, the first and second surface portions 13 and 14 commence to gradually open the occlusion, and further urging of the guide wire 1 causes the terminal member 7 to open the occlusion with the diameter of the opening formed in the occlusion corresponding to the diameter of the terminal member 7 adjacent the guide wire 1. Further urging of the guide wire 1 through the occlusion maintains the occlusion open with a diameter corresponding to that of the terminal member 7. Thereafter a catheter (not shown) is passed over the guide wire 1 and is guided into the occlusion. If the guide wire 1 is carrying a balloon, stent or other therapeutic device, the device is located in the opening formed in the occlusion by the terminal member 7, and the guide wire 1 and the catheter (not shown) are removed.

Prior to entering the guide wire 1 into the vascular system of the subject, the guide wire 1 may be bent adjacent the terminal member 7 thereof by bending the distal

portion 28 between the location 37 and the terminal member 7 in the direction of the arrows A or B for facilitating aligning of the terminal member 7 with a branched vessel of the vascular system as the guide wire 1 is being urged through the vascular system. Additionally, as mentioned above, the guide wire 1 may be supplied with the curved portion 38 already formed in the distal portion 28 as illustrated in Fig. 10, and if desired, the distal portion 28 may be bent between the location 37 and the terminal member 7 for urging the terminal member 7 out of the central major plane 35 for further enhancing alignment of the guide wire 1 with a branched vessel of the vascular system.

10

It is also envisaged that the terminal member 7 may be provided with wells or holes on its outer surface, in particular, along the first and second surface portions 13 and 14 for retaining therapeutic drugs or other compositions, liquid or otherwise, for assisting in urging of the guide wire 1 through the vascular system, and in particular, for assisting in urging the terminal member 7 through the occlusion or partial occlusion. Such drugs or other compositions, which may be in liquid, powder or other suitable form, may be drugs which would facilitate in dilation of a vessel, or dissolving the material of the occlusion. For example, if the occlusion were caused by a thrombosis, one of the drugs may be suitable for dissolving the thrombosis.

20

Referring now to Fig. 11, a terminal member, indicated generally by the reference numeral 50, of a guide wire (not shown) also according to the invention is illustrated. In this embodiment of the invention the core wire and sleeve of the guide wire are similar to the core wire 5 and the sleeve 10 of the guide wire 1 of Figs. 1 to 10. The terminal member 50 is substantially similar to the terminal member 7, and similar components are identified by the same reference numerals. In this embodiment of the invention a proximal portion 51 of the terminal member 50 is of outer circular transverse cross-section, and the terminal member 50 terminates in a leading edge portion 8 similar to the leading edge portion 8 of the terminal member 7. However, while an axial bore 19 extends into the terminal member 50 for engaging the distal end 4 of the core wire 5, the terminal member 50 is provided without a plug similar to the plug 17 of the terminal member 7. In this case the helical coil 10 would be

30

abutted against an end face 52, and would be brazed or soldered to the end face 52 with the outer surface defined by the helical coil coinciding with the outer surface defined by the proximal portion 51 of the terminal member 50. The soldering or brazing of the helical coil 10 to the end face 52 of the terminal member 50 could be carried out simultaneously with soldering or brazing the core wire 5 into the bore 19 of the terminal member 50, or after the terminal member 50 had been brazed or soldered to the core wire 5.

Referring now to Fig. 12, there is illustrated a terminal member 55 of a guide wire (not shown) also according to the invention. In this embodiment of the invention the core wire and the sleeve of the guide wire are similar to the core wire 5 and the sleeve 10 of the guide wire 1 of Figs. 1 to 10. The terminal member 55 is substantially similar to the terminal member 7 and similar components are identified by the same reference numerals. In this embodiment of the invention an axial plug 17 extends from the terminal member 55, however, the terminal member 55 is provided without an axial bore similar to the axial bore 19 of the terminal member 7. Thus, in this embodiment of the invention the axial plug 17 engages the bore 12, helical coil 10, and the distal end of the core wire 5 is abutted against an end face 56 of the terminal member 55 and brazed or soldered thereto.

Referring now to Fig. 13, there is illustrated a terminal member 60 of a guide wire (not shown) also according to the invention. In this embodiment of the invention the core wire and the sleeve of the guide wire are similar to the core wire 5 and the sleeve 10 of the guide wire 1 of Figs. 1 to 10. The terminal member 60 is substantially similar to the terminal member 7, and similar components are identified by the same reference numerals. The terminal member 60 comprises a proximal end portion 61 of circular transverse cross-section. However, in this embodiment of the invention the terminal member 60 comprises a first surface portion 62 which converges towards a second surface portion 63, the outer transverse cross-sectional profile of which coincides with the corresponding cross-sectional profile of the proximal end portion 61. The first surface portion 62 is convex in the longitudinal direction of the central axis 9 of the terminal member 60 and converges towards the

second surface portion 63 in a direction towards the leading edge portion 8 to form with the second surface portion 63, the transversely extending leading edge portion 8. The surface 15 of the leading edge portion 8 is radiused between the first and second surface portions 62 and 63, and defines one straight edge 64 adjacent the first surface portion 62 and one arcuate edge 65 adjacent the second surface portion 63. Additionally, side edges 66 of the first surface portion 62 are radiused to merge into the outer surface of the terminal member 60. In this embodiment of the invention the straight edge 64 of the leading edge portion 8 is contained in a plane which extends parallel to a plane containing the main central axis 6, but is offset therefrom.

Otherwise, the terminal member 60 is substantially similar to the terminal member 1.

The advantage of the terminal member 60 is that since the straight edge 64 of the leading edge portion 8 is offset from the main central axis 6, the guide wire according to this embodiment of the invention can be guided through a vascular system to access a space between layers of a vessel. This, thus, permits angioplasty or other surgical procedures to be carried out in a new sub-intimal lumen. Sub-intimal angioplasty is a technique where a lumen is created between the layers of the vessel adjacent to the true lumen of the vessel.

Referring now to Fig. 14, there is illustrated a terminal member 70 of a guide wire (not shown) also according to the invention. In this embodiment of the invention the core wire and the sleeve of the guide wire are similar to the core wire 5 and the sleeve 10 of the guide wire 1 of Figs. 1 to 10. The terminal member 70 is substantially similar to the terminal member 60 and similar components are identified by the same reference numerals. The main difference between the terminal member 70 and the terminal member 60 is that the first surface portion 62 is concave instead of convex. Otherwise, the terminal member 70 is similar to the terminal member 60. The advantage of providing the first surface portion 62 of concave shape as opposed to convex shape is that probing by the terminal member 70 may initially have less contact area due to the concave surface.

Referring now to Fig. 15, there is illustrated a terminal member 75 of a guide wire (not shown) also according to the invention. In this embodiment of the invention the core wire and the sleeve of the guide wire are similar to the core wire 5 and the sleeve 10 of the guide wire 1 of Figs. 1 to 10. The terminal member 75 is substantially similar to the terminal member 60 and similar components are identified by the same reference numerals. The main difference between the terminal member 75 and the terminal member 60 is that the first surface portion 62 is formed sequentially by a proximal convex portion 76 and a distal concave portion 77.

10 Additionally, the terminal member 75 is of a magnetic material, in this embodiment of the invention a ferrous material, so that the terminal member 75 can be urged through the vascular system, and also through an occlusion in a vessel of the vascular system by a magnetic field generated by a magnetic urging means (not shown), which would be located externally of the subject. Such an urging means, typically, would develop a magnetic field which could be moved and/or directed for urging the terminal member 75, and in turn, the guide wire (not shown) through the vascular system. Otherwise, the terminal member 75 is similar to the terminal member 60.

20 The advantage of providing the terminal member 75 of a magnetic material is that the member can be urged through the vascular system by an externally generated magnetic field, rather than by urging the terminal member 75 through the vascular system by pushing the guide wire 1 into the subject. By virtue of the fact that the terminal member 75 is urged by a magnetic field through the vascular system, rather than by pushing the guide wire 1 into the subject, minimises the danger of the terminal member 75 puncturing a vessel of the vascular system as the terminal member 75 is being urged therethrough. Additionally, by virtue of the fact that the guide wire is being pulled rather than being pushed, the guide wire can be provided with considerably more flexibility than could otherwise be provided if the guide wire were being pushed through the vascular system.

30

Referring now to Figs. 16 to 18, there is illustrated a terminal member 80 of a guide

wire also according to the invention, only a distal end portion 81 of the guide wire is illustrated. In this embodiment of the invention the core wire of the guide wire, the distal portion 28 of which is illustrated, and the sleeve 10, the distal portion also of which is illustrated, are similar to the core wire 5 and the sleeve 10 of the guide wire 1 of Figs. 1 to 10. The terminal member 80 is also substantially similar to the terminal member 7 described with reference to Figs. 1 to 10, and similar components are identified by the same reference numerals. In this embodiment of the invention the terminal member 80 is essentially formed by solder 82. The distal portion 28 of the core wire 5 extends beyond the sleeve 10, and is soldered to the sleeve 10 by the solder 82 which forms the terminal member 80. The leading edge portion 8 of the terminal member 80 is formed by a distal end 83 of the distal portion 28 of the core wire 5, and the solder 82 is shaped to form the first, second, third and fourth surface portions 13, 14, 18 and 21, respectively. However, in this embodiment of the invention the outer surface of the terminal member 80 at the proximal end portion 16 of the terminal member 80 formed by the solder 82 is of circular cross-section, and is of similar diameter to the outer diameter of the sleeve 10. Additionally, as well as the first and second surface portions 13 and 14 tapering towards the leading edge portion 8 of the terminal member 80, the third and fourth surface portions 18 and 21 also taper from the proximal end portion 16 of the terminal member 80 to the leading edge portion 8. The first, second, third and fourth surface portions 13, 14, 18 and 21, respectively, are radiused surfaces, and thus, are convex in transverse cross-section relative to the main central axis 6. The distal portion 28 of the guide wire 5 is centrally located in the sleeve 10, and accordingly, the plane containing the leading edge portion 8 also contains the main central axis 6 of the guide wire.

Otherwise, the guide wire and the terminal member 80 according to this embodiment of the invention is similar to the guide wire 1 and the terminal member 7, and their use is similar to that described with reference to the guide wire 1 of Figs. 1 to 10.

Referring now to Figs. 19 to 21, there is illustrated a terminal member 85 of a guide wire (not shown) also according to the invention. In this embodiment of the invention the core wire and the sleeve of the guide wire are similar to the core wire 5 and the

sleeve 10 of the guide wire 1 of Figs. 1 to 10. The terminal member 85 is substantially similar to the terminal member 7 of the guide wire 1 of Figs. 1 to 10, and similar components are identified by the same reference numerals. The main difference between the terminal member 85 and the terminal member 7 is that in the  
5 terminal member 85 the leading edge portion 8 extends at an angle  $\phi$  to the main central axis 6, which in this embodiment of the invention is approximately 70°.

Otherwise, the terminal member 85 and its use in conjunction with a guide wire is similar to the terminal member 7 of the guide wire 1 described with reference to Figs.  
10 1 to 10.

Referring now to Figs. 22 and 23, there is illustrated a terminal member 90 of a guide wire (not shown) also according to the invention. In this embodiment of the invention the core wire and the sleeve of the guide wire are similar to the core wire 5 and the sleeve 10 of the guide wire 1 of Figs. 1 to 10. The terminal member 90 is  
15 substantially similar to the terminal member 7 described with reference to Figs. 1 to 10 and similar components are identified by the same reference numerals. The main difference between the terminal member 90 and the terminal member 7 is that firstly, the leading edge portion 8 extends at an angle  $\phi$  to the main central axis 6,  
20 which in this embodiment of the invention is approximately 60°, and secondly, the third and fourth surface portions 18 and 21 converge from the proximal end portion 16 of the terminal member 90 to the leading edge portion 8. In this embodiment of the invention the first, second, third and fourth surface portions 13, 14, 18 and 21 are radiused, and thus are convex in a transverse direction relative to the main central  
25 axis 6.

Otherwise, the terminal member 90 is similar to the terminal member 7.

Referring now to Figs. 24 and 25, there is illustrated a terminal member 95 of a  
30 guide wire (not shown) also according to the invention. In this embodiment of the invention the core wire and sleeve of the guide wire are similar to the core wire 5 and the sleeve 10 of the guide wire 1 of Figs. 1 to 10. The terminal member 95 is

substantially similar to the terminal member 7, and similar components are identified by the same reference numerals. The main difference between the terminal member 95 and the terminal member 7 is that the leading edge portion 8 is radiused in plan view, and thus, is convex in plan view. Otherwise, the terminal member 95 is similar  
5 to the terminal member 7.

Referring now to Figs. 26 and 27, there is illustrated a terminal member 100 of a guide wire (not shown) also according to the invention. In this embodiment of the invention the core wire and the sleeve of the guide wire are similar to the core wire 5  
10 and the sleeve 10 of the guide wire 1 of Figs. 1 to 10. The terminal member 100 is substantially similar to the terminal member 7, and similar components are identified by the same reference numerals. The main difference between the terminal member 100 and the terminal member 7 is that the leading edge portion 8 is radiused in plan view, and in this embodiment of the invention is concave in plan view. Otherwise,  
15 the terminal member 100 is similar to the terminal member 7.

Referring now to Figs. 29 to 30, there is illustrated a terminal member 105 of a guide wire (not shown) also according to the invention. In this embodiment of the invention the core wire and the sleeve of the guide wire are similar to the core wire 5 and the  
20 sleeve 10 of the guide wire of Figs. 1 to 10. The terminal member 105 is substantially similar to the terminal member 7, and similar components are identified by the same reference numerals. The main difference between the terminal member 105 and the terminal member 7 is that the portion of the terminal member which extends between the proximal end portion 16 and the leading edge portion 8 along  
25 which the first and second surface portions 13 and 14 taper towards the leading edge portion is twisted through an angle of approximately 90°. Otherwise, the terminal member 105 is similar to the terminal member 7, and the use of the terminal member 105 and its guide wire is similar to the guide wire 1 described with reference to Figs. 1 to 10.

30

Referring now to Figs. 31 and 32, there is illustrated a terminal member 110 of a guide wire also according to the invention, only a distal portion 111 of the guide wire

is illustrated in Figs. 31 and 32. In this embodiment of the invention the core wire, the distal portion 28 of which is illustrated and the sleeve, a distal portion 10 of which is illustrated, of the guide wire are similar to the core wire 5 and the sleeve 10 of the guide wire 1 of Figs. 1 to 10. The terminal member 110 is substantially similar to the terminal member 7 of the guide wire 1 of Figs. 1 to 10, and similar components are identified by the same reference numerals. Additionally, the terminal member 110 of this embodiment of the invention is somewhat similar to the terminal member 80 described with reference to Figs. 16 to 18. In this embodiment of the invention the terminal member 110 is essentially formed by solder 112 which solders the distal portion 28 of the guide wire to the sleeve 10 of the guide wire. The main difference between the terminal member 110 and the terminal member 80 is that in this embodiment of the invention the distal portion 28 of the core wire is wider than the distal portion of the guide wire of Figs. 16 to 18, and thus, the leading edge portion 8 of the terminal member 110 is longer than the leading edge portion 8 of the terminal member 80. Additionally, the reinforcing rib 36 of the distal portion 28 of the core wire 5, in this embodiment of the invention, extends into the terminal member 110. The solder 112 is shaped to form the terminal member 110 in similar fashion as the solder 82 is shaped to form the terminal member 80.

Otherwise, the terminal member 110 is similar to the terminal member 80, which in turn is substantially similar to the terminal member 7.

Referring now to Figs. 33 and 34, there is illustrated a terminal member 115 of a guide wire also according to the invention, only a distal end 116 of the guide wire is illustrated. In this embodiment of the invention the core wire and sleeve of the guide wire are similar to the core wire 5 and the sleeve 10 of the guide wire 1 of Figs. 1 to 10. The terminal member 115 is substantially similar to the terminal member 110, which in turn is substantially similar to the terminal member 7, and similar components are identified by the same reference numerals. The main difference between the terminal member 115 and the terminal member 110 is that a distal portion extension 119 is secured to the distal portion 28 of the core wire 5, and is not centrally located in the sleeve 10. Rather, the distal portion extension 119 defines a

central major plane 135, which is parallel to but offset from a plane containing the main central axis 6. As in the case of the terminal member 110, the terminal member 115 is essentially formed by solder 117, and accordingly, by virtue of the fact that the distal portion extension 119 is offset from the main central axis 6, the leading edge portion 8 of the terminal member 115, which is formed by a distal end 118 of the distal portion extension 119 of the core wire 5, is contained in a plane which extends parallel to a plane containing the main central axis 6 of the core wire, but is offset therefrom. Otherwise, the terminal member 115 is substantially similar to the terminal member 110, which in turn is substantially similar to the terminal member 7.

Referring now to Fig. 35, there is illustrated a terminal member 120 of a guide wire (not shown) also according to the invention. In this embodiment of the invention the core wire and the sleeve of the guide wire are similar to the core wire 5 and sleeve 10 of the guide wire 1 of Figs. 1 to 10. The terminal member 120 is substantially similar to the terminal member 7, and similar components are identified by the same reference numerals. The main difference between the terminal member 120 and the terminal member 7 is that in this embodiment of the invention only the first surface portion 13 is angled to converge with the second surface portion 14. Otherwise, the terminal member 120 is similar to the terminal member 7.

Referring now to Figs. 36 and 37, there is illustrated a terminal member 125 of a guide wire (not shown) also according to the invention. In this embodiment of the invention the core wire and the sleeve of the guide wire are similar to the core wire 5 and the sleeve 10 of the guide wire 1 of Figs. 1 to 10. The terminal member 125 is substantially similar to the terminal member 7, and similar components are identified by the same reference numerals. The main difference between the terminal member 125 and the terminal member 7 is that a leading portion 126 of the terminal member 125 is of wedge shape construction, and extends from an intermediate portion 127 which is located between the proximal end portion 16 and the leading portion 126. The leading portion 126 defines the leading edge portion 8 which extends transversely relative to the main central axis 6 of the guide wire, and is contained in

a plane which also contains the main central axis 6.

The first and second surface portions 13 and 14 extend from the proximal end portion 16 to the leading edge portion 8 and converge along the intermediate portion 127 and the leading portion 126. However, the portion of the first and second surface portions 13 and 14 which are defined by the intermediate portion 127 are radiused, and thus, convex in a direction transversely of the main central axis 6, while the portion of the first and second surface portions 13 and 14 defined by the leading portion 126 are planar surfaces. The third and fourth surface portions 18 and 21, which are defined by the leading portion 126 are planar surfaces, and extend parallel to each other. However, the portions of the third and fourth surface portions 18 and 20 which are defined by the intermediate portion 127 converge from the proximal end portion 16 to the leading portion 126. The third and fourth surface portions 18 and 21 which are defined by the intermediate portion 127 are radiused, and thus, convex in a direction transversely of the main central axis 6 of the guide wire.

Otherwise, the terminal member 127 is similar to the terminal member 7.

Referring now to Figs. 38 and 39, there is illustrated a terminal member 140 of a guide wire (not shown) also according to the invention. In this embodiment of the invention the core wire and the sleeve of the guide wire are similar to the core wire 5 and the sleeve 10 of the guide wire 1 of Figs. 1 to 10. The terminal member 140 is substantially similar to the terminal member 7, and similar components are identified by the same reference numerals. The main difference between the terminal member 140 and the terminal member 7 is that the acute angle  $\alpha$  defined by the first and second surface portions 13 and 14 is less than the acute angle  $\alpha$  defined by the first and second surface portions 13 and 14 of the terminal member 7, and accordingly, the length of the first and second surface portions 13 and 14 between the proximal end portion 16 and the leading edge portion 8 is longer in the terminal member 140 than it is in the terminal member 7. Additionally, the portion of the terminal member 140 extending between the proximal end portion 16 and the leading edge portion 8 is

bent at an angle  $\beta$  out of the central major plane 26 defined by the first and second surface portions 13 and 14, so that the leading edge portion 8 is offset from the main central axis 6, for facilitating guiding of the terminal member 140, and in turn the guide wire into a branching vessel. Otherwise, the terminal member 140 is similar to the terminal member 7, and its use along with the guide wire according to this embodiment of the invention is similar to that of the guide wire 1 described with reference to Figs. 1 to 10.

While the guide wire according to the invention has been described for use in opening an occluded vessel in the cardiovascular system of a human or animal subject, it will be readily apparent to those skilled in the art that the guide wire according to the invention may be used for opening a vascular occlusion in any other vascular system of the human or animal body.

While the sleeve extending around the core wire 5 adjacent its distal end has been described as being provided by a helical coil, any other suitable sleeve may be provided, for example, in certain cases, it is envisaged that the sleeve may be provided as a sleeve of plastics material, composite polymer material, or any other polymer material.

It will be appreciated that the guide wire may be produced of materials other than those described, for example, the core wire may be of any other suitable material besides stainless steel, for example, nickel titanium alloy, MP35N, composite polymers, and the like. Similarly, the helical coil or other sleeve may be of any other suitable material besides stainless steel, for example, nickel titanium alloy, MP35N, composite polymers, and the like, and the terminal member may be of any other material besides platinum alloy, however, it is preferable that the terminal member or a portion thereof or a portion of the guide wire adjacent the terminal member should be of a radiopaque material. Where the terminal member is of a magnetic material, the magnetic material may be any other suitable magnetic material besides that described with reference to the terminal member 75 of Fig. 15. Indeed, in certain cases it is envisaged that the terminal member may be constructed only partly of a

magnetic material. However, it is preferable that the terminal member, even where it is of a magnetic material, should be of a radiopaque material for facilitating tracking of the terminal member as it is being urged through the vascular system.

5     Needless to say, while only the terminal member 75 has been described as being of a magnetic material, it will be readily apparent to those skilled in the art that any of the other terminal members described may be of a magnetic material.

Needless to say, any other suitable securing means for securing the terminal  
10     member to the core wire and to the helical coil or other sleeve may be used besides soldering and brazing. Indeed, in certain cases, it is envisaged that the terminal member may be secured to the core wire and the helical coil or other sleeve by welding, adhesive or any other suitable securing means. It is also envisaged in certain cases that the terminal member may be integrally formed with the core wire  
15     from the same material.

Furthermore, while the terminal member in some of the embodiments of the invention described with reference to the drawings has been described as being formed or partly formed by solder, it will be appreciated that instead of the terminal  
20     member being formed or partly formed by solder, it may be formed or partly formed by any other suitable material, for example, a brazing material, a welding material, indeed, by an adhesive or any other suitable filler material.

It is also envisaged that while in some of the embodiments of the invention described  
25     with reference to the drawings the terminal member has been described as having a bore extending into the terminal member for engaging the distal portion of the core wire, in certain cases, it is envisaged that a plug portion may extend from the terminal member for securing to the distal portion of the core wire by any suitable securing means, for example, soldering, brazing, welding or adhesive. In which  
30     case, it is envisaged that, in general, the plug portion would be a relatively flat member in order to abut and lie parallel to one of the major surfaces of the distal portion of the core wire.

Additionally, while the terminal members of the guide wires described with reference to the drawings in general have been described as having first and second surface portions joined by third and fourth surface portions, which extend to the leading edge portion from the proximal end portion, it is envisaged in certain cases that a portion of the first surface portion may be formed by portions of the third and fourth surface portions, so that when viewed from the distal end of the terminal member in the direction of the proximal end thereof, the transverse cross-section of the terminal member would be substantially triangular. The base of the triangle forming the second surface portion and the leading edge portion, while the two sides of the triangle would form the third and fourth surface portions, or the first surface portion, depending on how the terminal member is viewed. In which case, it is envisaged that the surface portion of the terminal member forming the base of the triangle may be planar or convex when viewed in a transverse direction, and the portions of the surface of the terminal member forming the two sides of the triangle may be planar or convex when viewed in a transverse direction. In such cases, the first surface portion may be formed by the apex of the triangle defined by the third and fourth sides thereof, and the apex may be radiused or not radiused.

It is also envisaged that the third and fourth surface portions of the terminal member may be planar, convex or concave in a longitudinal direction, or may be a combination of one or more of planar, concave and convex in a longitudinal direction.

Claims

1. A guide wire for use in a re-canalising process for re-canalising a vascular occlusion in a human or animal subject, the guide wire extending between a proximal end and a distal end, and defining a longitudinally extending main central axis, characterised in that the guide wire terminates at its distal end in a terminal member extending axially from the guide wire, the terminal member tapering to a distal leading edge portion for engaging and gradually opening the occlusion as the terminal member is urged therethrough.
2. A guide wire as claimed in Claim 1 characterised in that the leading edge portion is an elongated leading edge portion.
3. A guide wire as claimed in Claim 1 or 2 characterised in that the leading edge portion extends in a direction at an angle relative to an axial direction defined by the main central axis.
4. A guide wire as claimed in any preceding claim characterised in that the leading edge portion extends in a direction at an angle in the range of  $1^\circ$  to  $90^\circ$  relative to an axial direction defined by the main central axis.
5. A guide wire as claimed in Claim 4 characterised in that the leading edge portion extends in a direction at an angle in the range of  $30^\circ$  to  $90^\circ$  relative to an axial direction defined by the main central axis.
6. A guide wire as claimed in Claim 5 characterised in that the leading edge portion extends in a direction at an angle of approximately  $60^\circ$  relative to an axial direction defined by the main central axis.
7. A guide wire as claimed in any preceding claim characterised in that the leading edge portion extends in a direction substantially transversely of the main central axis.

8. A guide wire as claimed in any preceding claim characterised in that a first surface portion of the terminal member converges towards an opposite second surface portion thereof towards the leading edge portion.

5 9. A guide wire as claimed in Claim 8 characterised in that the first surface portion of the terminal member is planar.

10 10. A guide wire as claimed in Claim 8 characterised in that the first surface portion of the terminal member is convex in a longitudinal direction relative to the main central axis.

11. A guide wire as claimed in Claim 8 characterised in that the first surface portion of the terminal member is concave in a longitudinal direction relative to the main central axis.

15

12. A guide wire as claimed in Claim 8 characterised in that the first surface portion of the terminal member is sequentially convex and concave in a longitudinal direction relative to the main central axis.

20 13. A guide wire as claimed in any of Claims 8 to 12 characterised in that a distal portion of the first surface portion of the terminal member is concave in a longitudinal direction relative to the main central axis.

25 14. A guide wire as claimed in any of Claims 8 to 13 characterised in that a proximal portion of the first surface portion of the terminal member is convex in a longitudinal direction relative to the main central axis.

30 15. A guide wire as claimed in any of Claims 8 to 14 characterised in that the first surface portion of the terminal member is convex in a transverse direction relative to the main central axis.

16. A guide wire as claimed in any of Claims 8 to 15 characterised in that the

second surface portion of the terminal member converges towards the first surface portion towards the leading edge portion.

17. A guide wire as claimed in any of Claims 8 to 16 characterised in that the  
5 second surface portion of the terminal member is planar.

18. A guide wire as claimed in any of Claims 8 to 16 characterised in that the  
second surface portion of the terminal member is convex in a longitudinal direction  
relative to the main central axis.

10

19. A guide wire as claimed in any of Claims 8 to 16 characterised in that the  
second surface portion of the terminal member is concave in a longitudinal direction  
relative to the main central axis.

15 20. A guide wire as claimed in any of Claims 8 to 16 characterised in that the  
second surface portion of the terminal member is sequentially convex and concave  
in a longitudinal direction relative to the main central axis.

21. A guide wire as claimed in any of Claims 8 to 20 characterised in that a distal  
20 portion of the second surface portion of the terminal member is concave.

22. A guide wire as claimed in any of Claims 8 to 21 characterised in that a  
proximal portion of the second surface portion of the terminal member is convex.

25 23. A guide wire as claimed in any of Claims 8 to 22 characterised in that the  
second surface portion of the terminal member is convex in a transverse direction  
relative to the main central axis.

24. A guide wire as claimed in any of Claims 8 to 23 characterised in that the first  
30 and second surface portions terminate in the leading edge portion to define the  
leading edge portion as a chisel edge.

25. A guide wire as claimed in any of Claims 8 to 24 characterised in that the first and second surface portions of the terminal member define an included angle in the range of  $1^\circ$  to  $179^\circ$ .
- 5 26. A guide wire as claimed in any of Claims 8 to 25 characterised in that the first and second surface portions of the terminal member define an included angle in the range of  $5^\circ$  to  $90^\circ$ .
27. A guide wire as claimed in any of Claims 8 to 26 characterised in that the first  
10 and second surface portions of the terminal member define an included angle of approximately  $15^\circ$ .
28. A guide wire as claimed in any of Claims 8 to 27 characterised in that the first  
15 and second surface portions of the terminal member are joined by spaced apart opposite third and fourth surface portions.
29. A guide wire as claimed in Claim 28 characterised in that the leading edge  
portion of the terminal member extends between the third and fourth surface  
portions.  
20
30. A guide wire as claimed in Claim 28 or 29 characterised in that the third and fourth surface portions of the terminal member are planar surfaces.
31. A guide wire as claimed in Claim 28 or 29 characterised in that the third and  
25 fourth surface portions of the terminal member are convex in a transverse direction relative to the main central axis.
32. A guide wire as claimed in any of Claims 28 to 31 characterised in that the  
third and fourth surface portions of the terminal member are parallel to each other in  
30 an axial direction defined by the main central axis.
33. A guide wire as claimed in any of Claims 28 to 31 characterised in that the

third and fourth surface portions of the terminal member taper towards the leading edge portion.

34. A guide wire as claimed in Claim 32 characterised in that the third and fourth  
5 surface portions of the terminal member define an included angle in the range of  $1^\circ$   
to  $179^\circ$ .

35. A guide wire as claimed in Claim 33 characterised in that the third and fourth  
10 surface portions of the terminal member define an included angle in the range of  $5^\circ$   
to  $90^\circ$ .

36. A guide wire as claimed in Claim 34 characterised in that the third and fourth  
15 surface portions of the terminal member define an included angle of approximately  
 $15^\circ$ .

37. A guide wire as claimed in any of Claims 28 to 36 characterised in that the  
third surface portion of the terminal member is convex in a longitudinal direction  
relative to the main central axis.

20 38. A guide wire as claimed in any of Claims 28 to 36 characterised in that the  
third surface portion of the terminal member is concave in a longitudinal direction  
relative to the main central axis.

39. A guide wire as claimed in any of Claims 28 to 36 characterised in that the  
25 third surface portion of the terminal member is sequentially convex and concave in a  
longitudinal direction relative to the main central axis.

40. A guide wire as claimed in any of Claims 28 to 39 characterised in that a  
30 distal portion of the third surface portion of the terminal member is concave in a  
longitudinal direction relative to the main central axis.

41. A guide wire as claimed in any of Claims 28 to 40 characterised in that a

proximal portion of the third surface portion of the terminal member is convex in a longitudinal direction relative to the main central axis.

42. A guide wire as claimed in any of Claims 28 to 41 characterised in that the  
5 fourth surface portion of the terminal member is convex in a longitudinal direction relative to the main central axis.

43. A guide wire as claimed in any of Claims 28 to 41 characterised in that the  
10 fourth surface portion of the terminal member is concave in a longitudinal direction relative to the main central axis.

44. A guide wire as claimed in any of Claims 28 to 41 characterised in that the  
fourth surface portion of the terminal member is sequentially convex and concave in a longitudinal direction relative to the main central axis.

15 45. A guide wire as claimed in any of Claims 28 to 44 characterised in that a distal portion of the fourth surface portion of the terminal member is concave in a longitudinal direction relative to the main central axis.

20 46. A guide wire as claimed in any of Claims 28 to 45 characterised in that a proximal portion of the fourth surface portion of the terminal member is convex in a longitudinal direction relative to the main central axis.

47. A guide wire as claimed in any of Claims 8 to 46 characterised in that the  
25 leading edge portion is radiused from the first surface portion of the terminal member to the second surface portion thereof.

48. A guide wire as claimed in any preceding claim characterised in that the  
leading edge portion is radiused in plan view.

30 49. A guide wire as claimed in any preceding claim characterised in that the leading edge portion is convex in plan view.

50. A guide wire as claimed in any of Claims 1 to 48 characterised in that the leading edge portion is concave in plan view.

5 51. A guide wire as claimed in any preceding claim characterised in that the maximum outer transverse cross-sectional area of the terminal member is substantially similar to the outer transverse cross-sectional area of the guide wire adjacent the terminal member.

10 52. A guide wire as claimed in any preceding claim characterised in that the outer transverse cross-sectional area of the terminal member adjacent the guide wire is similar to the outer transverse cross-sectional area of the guide wire adjacent the terminal member so that the outer surface of the terminal member is in axial alignment with the outer surface of the guide wire adjacent the terminal member.

15

53. A guide wire as claimed in any preceding claim characterised in that the guide wire adjacent the terminal member and the terminal member adjacent the guide wire are of circular transverse cross-section, and are of substantially similar outer diameters.

20

54. A guide wire as claimed in any preceding claim characterised in that the transverse width of the leading edge portion does not exceed the transverse width of the guide wire adjacent the terminal member in a plane containing the leading edge portion and extending parallel to the main central axis.

25

55. A guide wire as claimed in any preceding claim characterised in that the guide wire comprises an elongated core wire extending from the proximal end to the distal end.

30 56. A guide wire as claimed in Claim 55 characterised in that the terminal member is secured to the distal end of the core wire.

57. A guide wire as claimed in Claim 55 or 56 characterised in that the core wire terminates in a distal portion of rectangular transverse cross-section defining first and second opposite major surfaces joined by first and second opposite minor surfaces for facilitating bending thereof for offsetting the terminal member relative to the main central axis for facilitating guiding of the terminal member into a branched vessel of a vascular system.

58. A guide wire as claimed in Claim 57 characterised in that the first and second major surfaces of the distal portion of the core wire converge towards each other towards the distal end thereof.

59. A guide wire as claimed in Claim 58 characterised in that the first and second major surfaces of the distal portion of the core wire extend substantially parallel to each other.

60. A guide wire as claimed in Claim 58 or 59 characterised in that the first and second minor surfaces of the distal portion of the core wire diverge from each other towards the distal end thereof.

61. A guide wire as claimed in Claim 58 or 59 characterised in that the first and second minor surfaces of the distal portion of the core wire extend substantially parallel to each other.

62. A guide wire as claimed in any of Claims 57 to 61 characterised in that a reinforcing means is provided on the distal portion of the core wire for minimising axial twisting thereof.

63. A guide wire as claimed in any of Claims 57 to 62 characterised in that the first and second major surfaces of the distal portion of the core wire define therebetween a central major plane extending parallel to the main central axis and cutting the first and second minor surfaces, and the distal portion is curved in the central major plane for offsetting the terminal member relative to the main central

axis for in turn facilitating guiding of the terminal member into a branched vessel of a vascular system.

64. A guide wire as claimed in Claim 63 characterised in that the central major  
5 plane defined by the first and second major surfaces of the distal portion of the core wire extends transversely of a plane containing the leading edge portion of the terminal member and extending parallel to the main central axis.

65. A guide wire as claimed in Claim 63 characterised in that the central major  
10 plane defined by the first and second major surfaces of the distal portion of the core wire extends substantially parallel to a plane containing the leading edge portion of the terminal member and extending parallel to the main central axis.

66. A guide wire as claimed in any of Claims 57 to 65 characterised in that the  
15 core wire extending from the distal portion thereof to the proximal end is of circular transverse cross-section.

67. A guide wire as claimed in any of Claims 55 to 66 characterised in that a  
20 sleeve extends along the core wire from the terminal member and terminates at a location intermediate the distal end and the proximal end of the core wire.

68. A guide wire as claimed in Claim 67 characterised in that the sleeve is of external circular transverse cross-section.

25 69. A guide wire as claimed in Claim 68 characterised in that the external diameter of the sleeve is substantially similar to the diameter of the terminal member adjacent the guide wire.

30 70. A guide wire as claimed in any of Claims 67 to 69 characterised in that the sleeve comprises a helical coil located around the core wire adjacent the distal end thereof.

71. A guide wire as claimed in any of Claims 67 to 70 characterised in that a plug extends from the terminal member adjacent a proximal end thereof for engaging an internal bore defined by the sleeve for securing the sleeve to the terminal member.
- 5 72. A guide wire as claimed in any of Claims 67 to 71 characterised in that the terminal member is secured to the sleeve by brazing or soldering.
73. A guide wire as claimed in any of Claims 55 to 72 characterised in that a core wire engaging bore extends into the terminal member for engaging the distal end of  
10 the core wire.
74. A guide wire as claimed in Claim 73 characterised in that the core wire engaging bore extends axially into the terminal member.
- 15 75. A guide wire as claimed in any of Claims 55 to 74 characterised in that the terminal member is secured to the core wire by brazing, or soldering, welding or adhesive.
76. A guide wire as claimed in Claim 75 characterised in that the soldering,  
20 brazing, welding or adhesive material is a radiopaque material.
77. A guide wire as claimed in any preceding claim characterised in that at least a portion of the terminal member is of radiopaque material.
- 25 78. A guide wire as claimed in any preceding claim characterised in that at least a portion of the terminal member is of a magnetic material for facilitating urging of the terminal member through a vascular system by a magnetic urging means located externally of the subject.
- 30 79. A guide wire as claimed in Claim 78 characterised in that the terminal member is of a magnetic material.

80. A guide wire as claimed in any preceding claim characterised in that a distal portion of the guide wire is of a magnetic material for facilitating urging of the terminal member through a vascular system by a magnetic urging means located externally of the subject.

5

81. In combination the guide wire as claimed in any of Claims 78 to 80 and a magnetic urging means for urging the terminal member through a vascular occlusion.

10

82. In combination the guide wire as claimed in any of Claims 78 to 80 and a magnetic urging means for urging the terminal member through a vascular system to a vascular occlusion.

15

83. A method for re-canalising a vascular occlusion in a human or animal subject, the method comprising urging the terminal member of the guide wire of any of Claims 1 to 53 through the occlusion for gradually opening thereof.

20

84. A method as claimed in Claim 83 characterised in that the terminal member is urged by the guide wire through a vascular system to the occlusion prior to being urged through the occlusion.

25

85. A method as claimed in Claim 83 or 84 characterised in that the terminal member is urged through the occlusion by a magnetic urging means located externally of the subject.

86. A method as claimed in any of Claims 83 to 85 characterised in that the terminal member is urged through a vascular system by a magnetic urging means located externally of the subject.

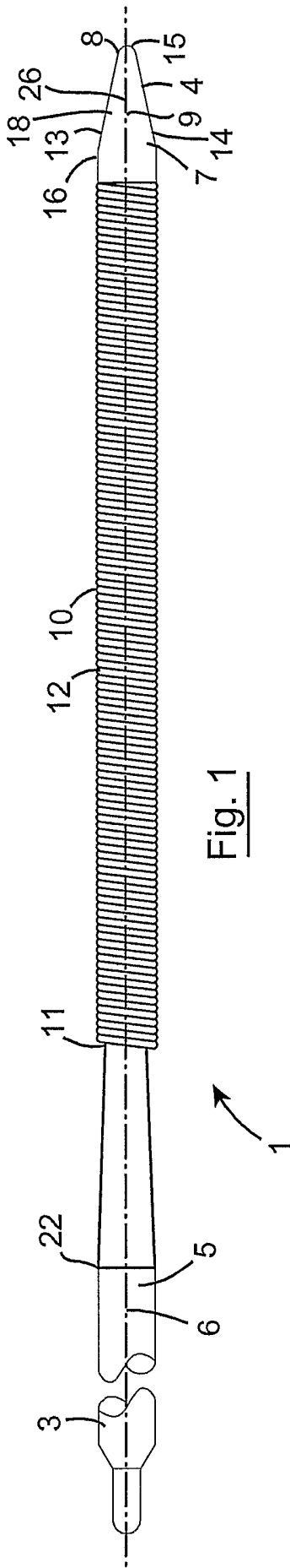

Fig. 1

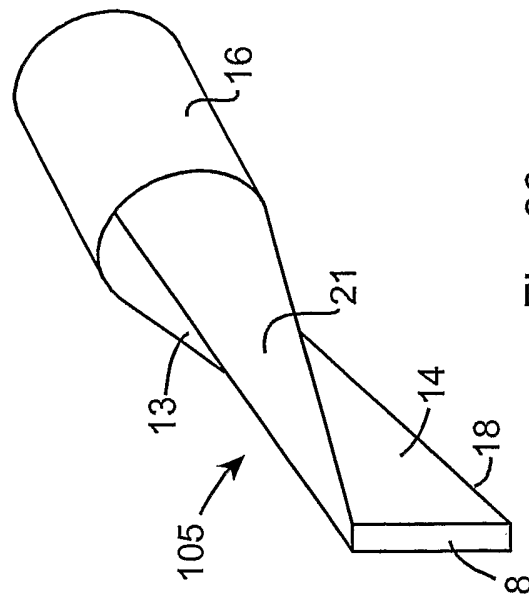

Fig. 30

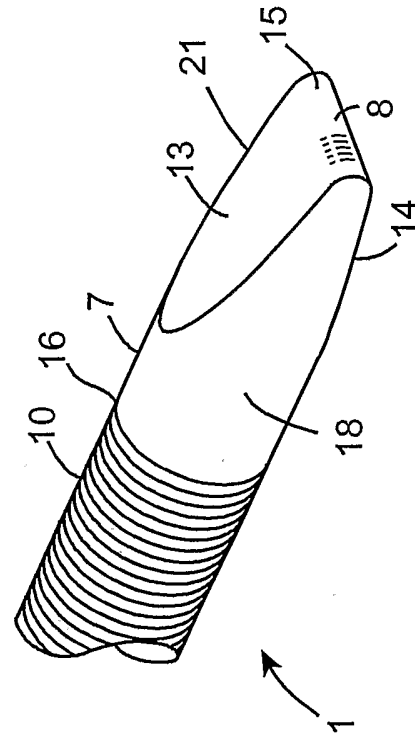

Fig. 2

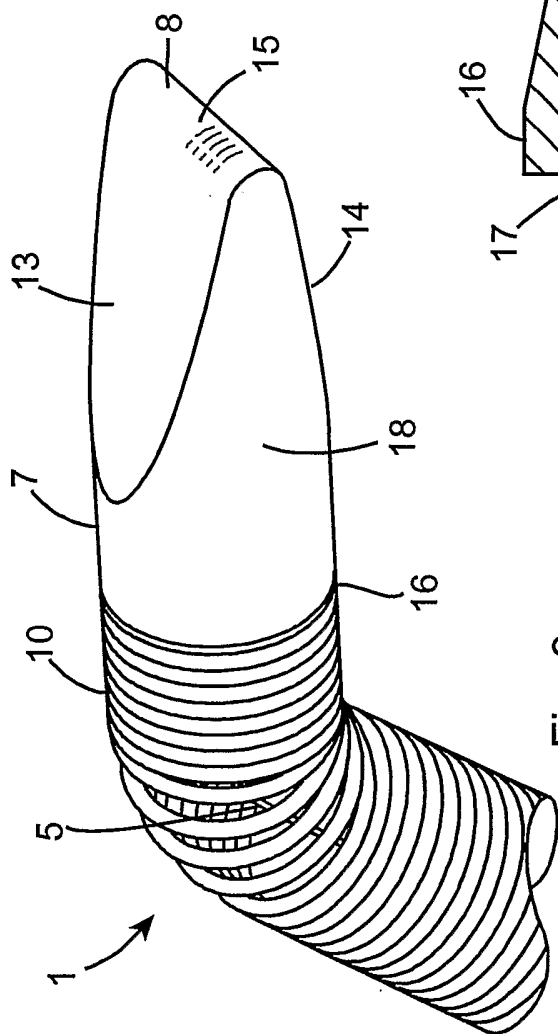

Fig. 3

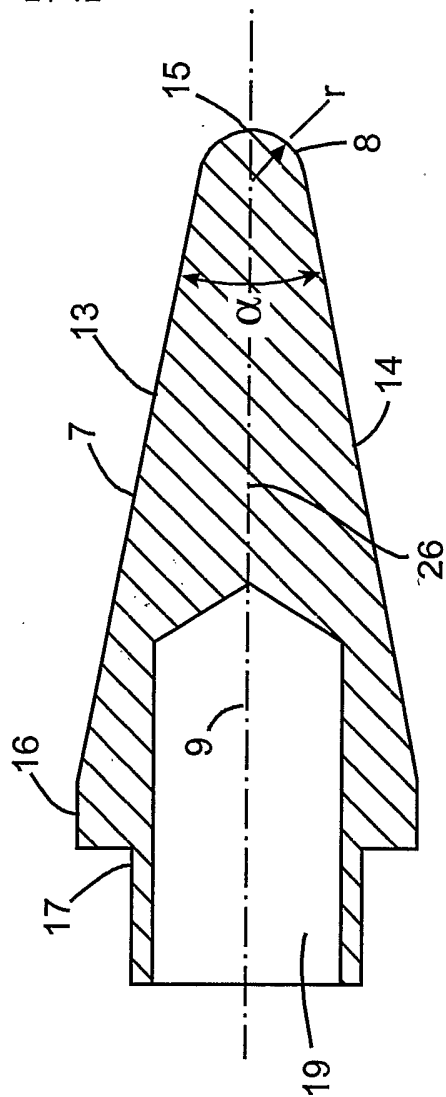

Fig. 7

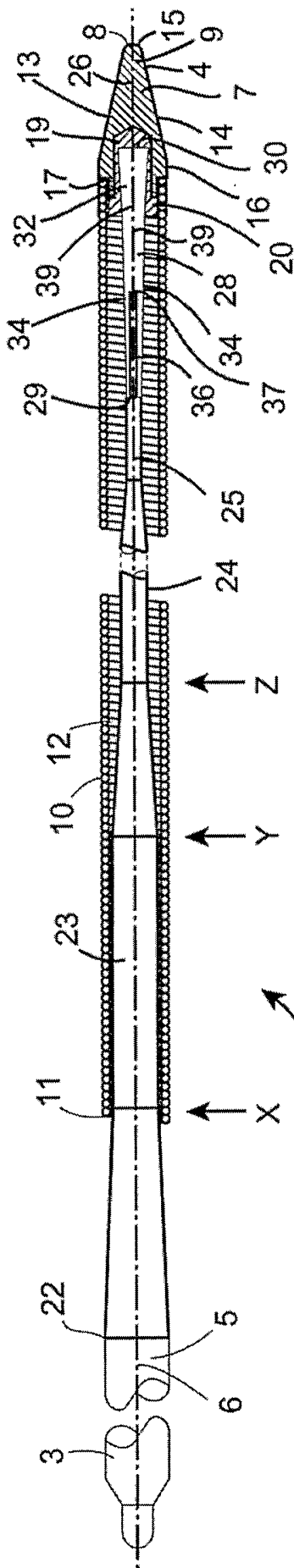

Fig. 4

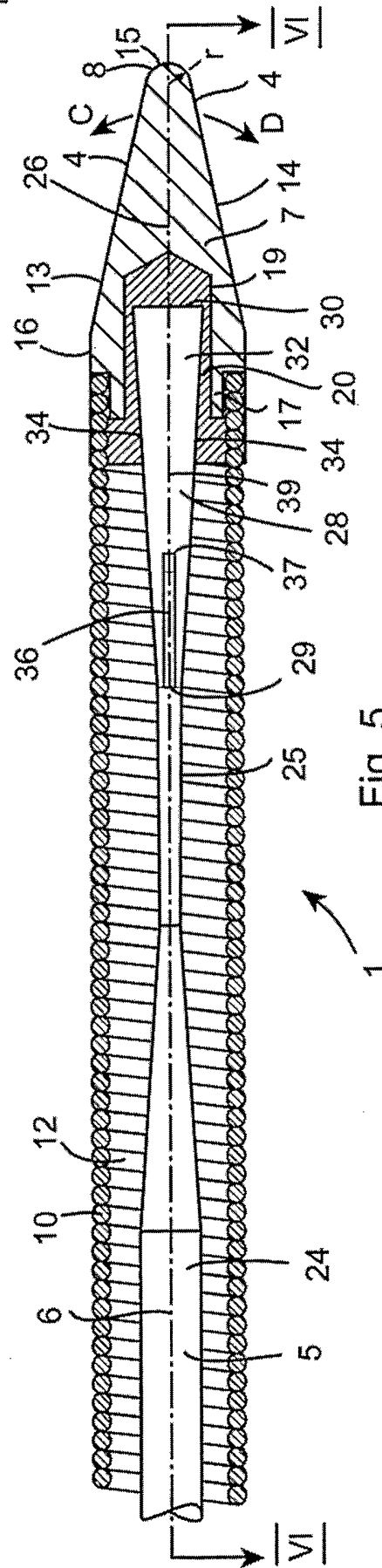

Fig. 5

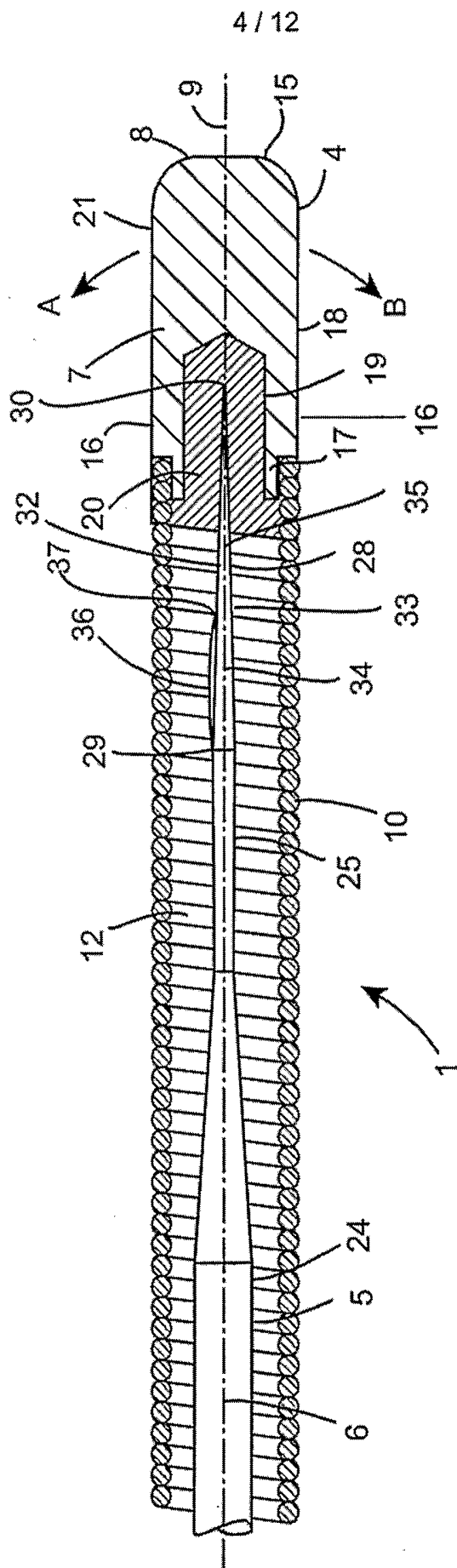

Fig. 6

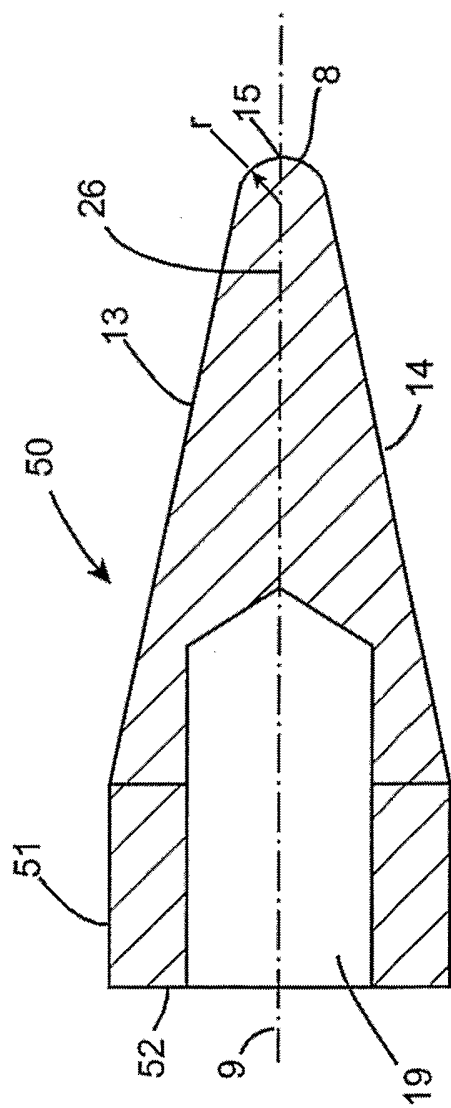

Fig. 11

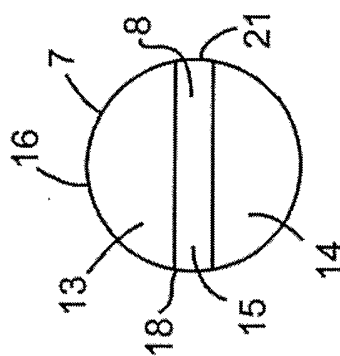
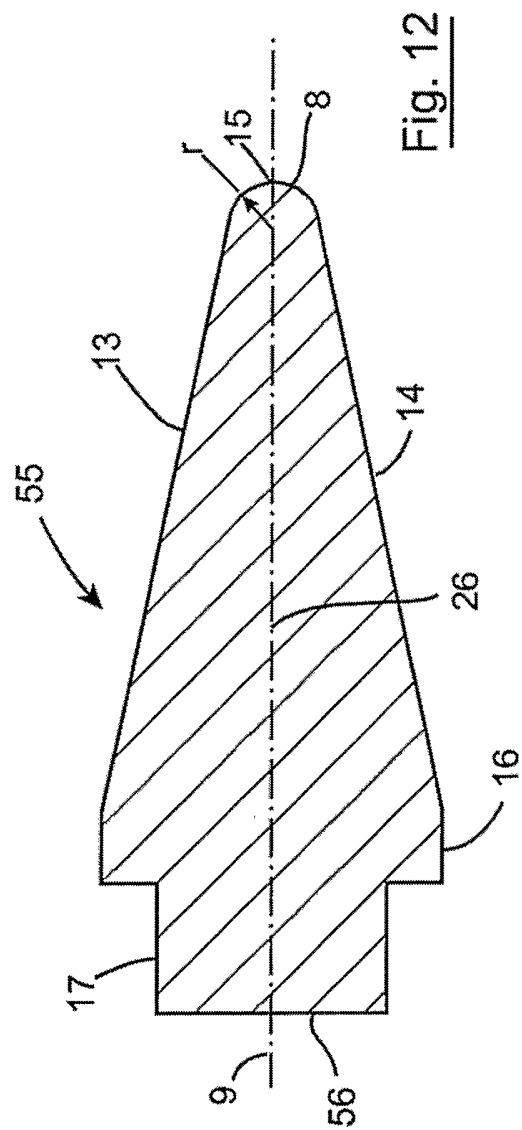
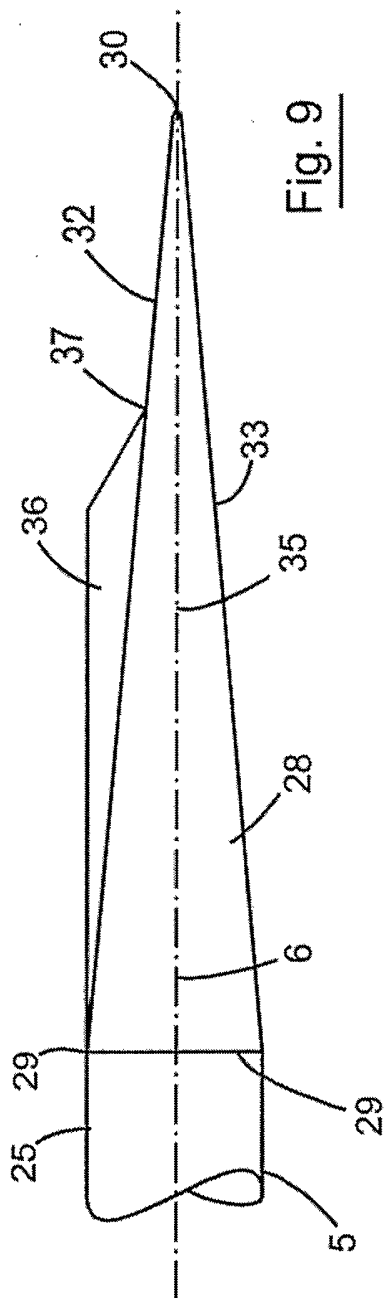
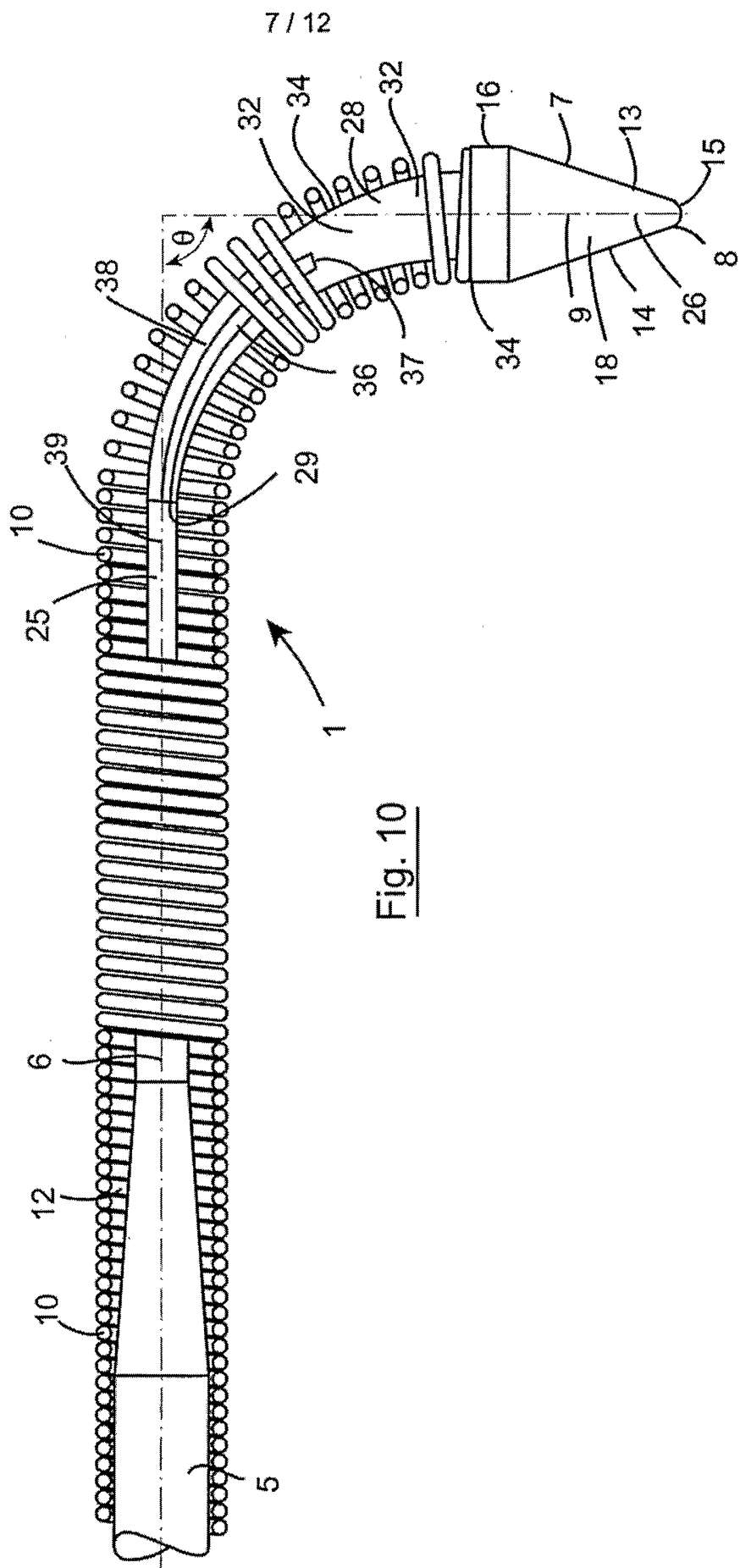

Fig. 8





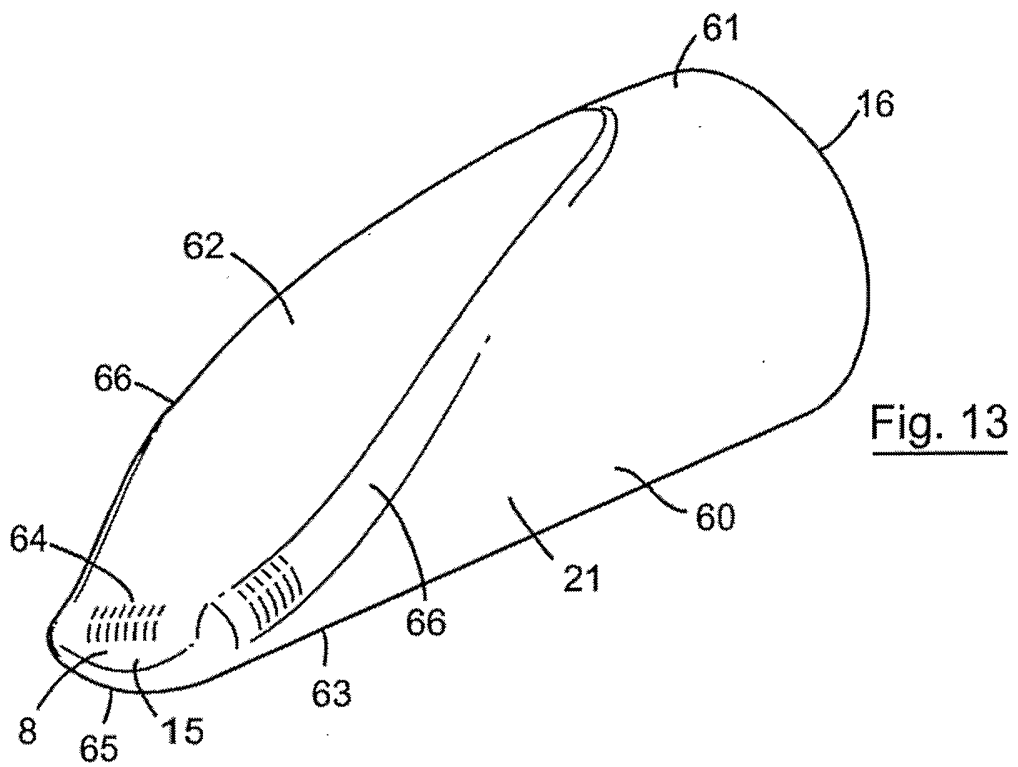

Fig. 13

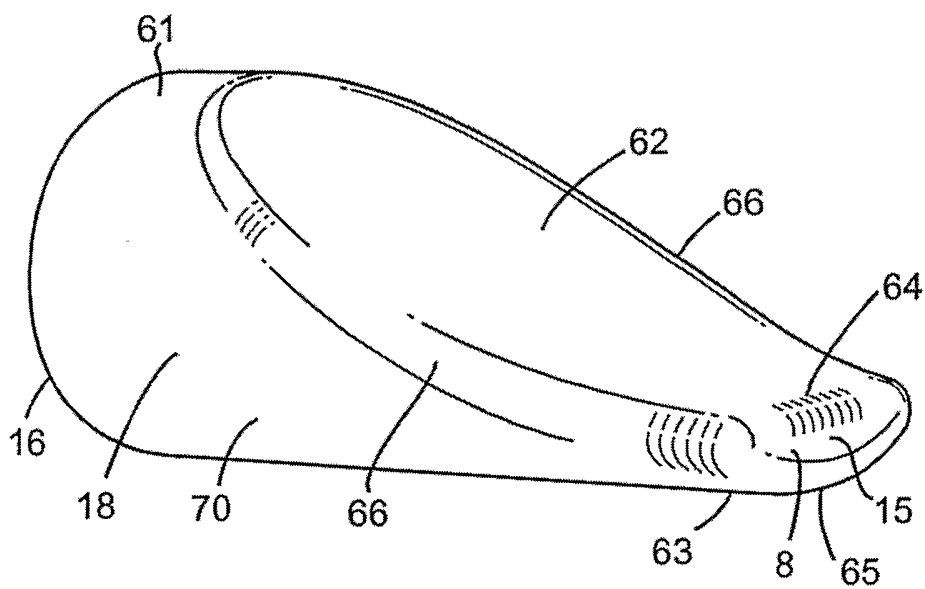

Fig. 14

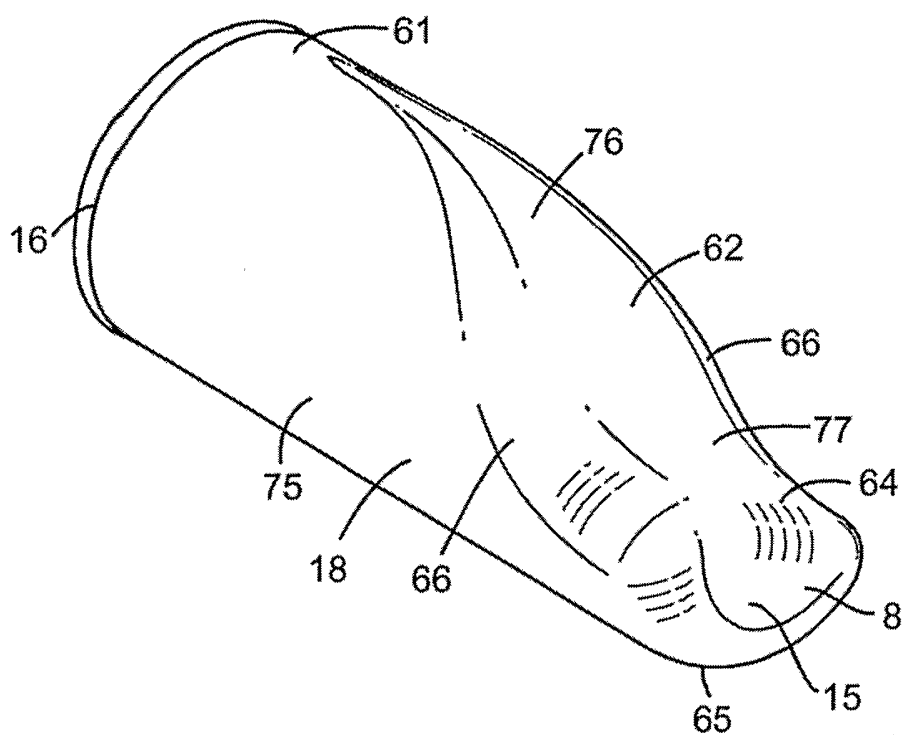

Fig. 15

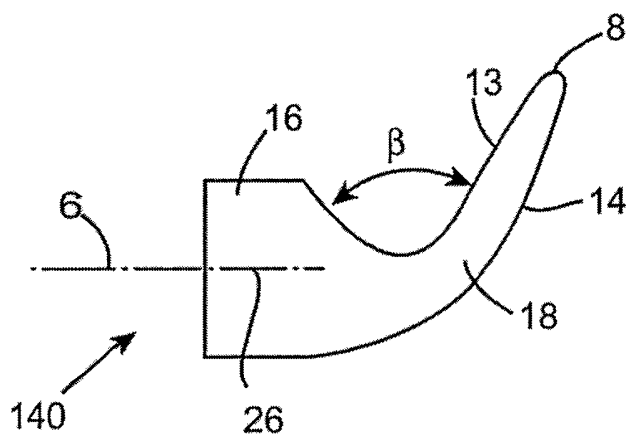

Fig. 38

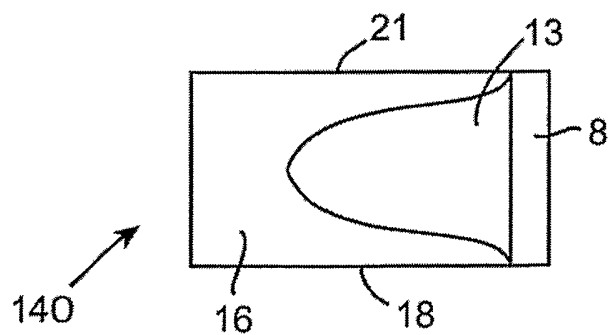
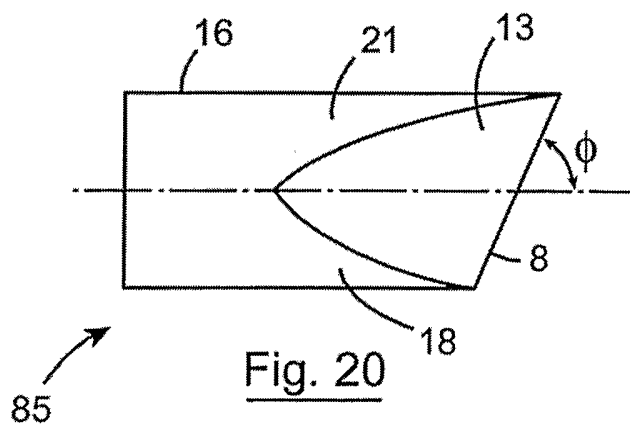
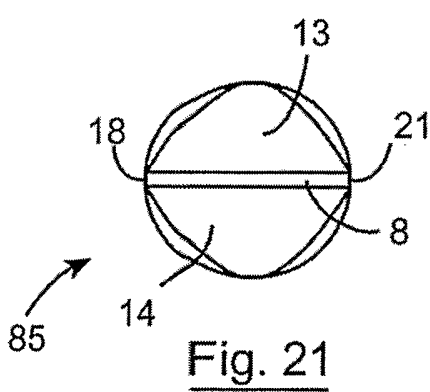
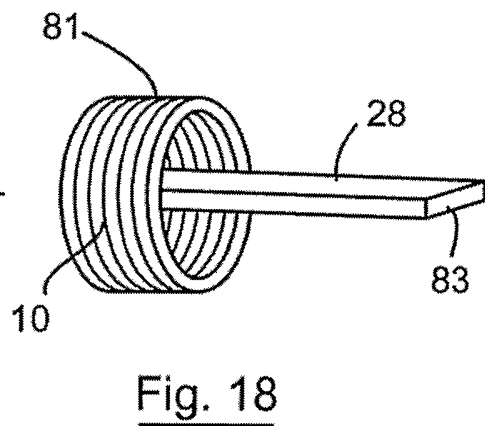
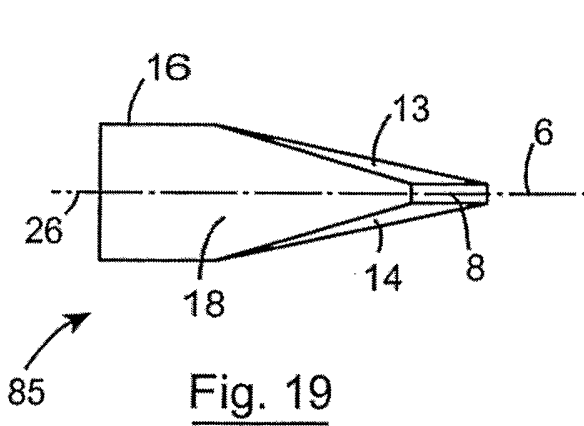
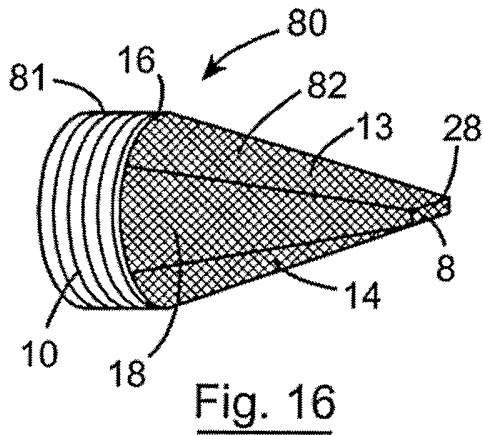
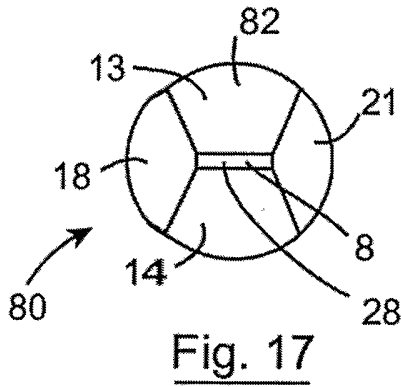

Fig. 39



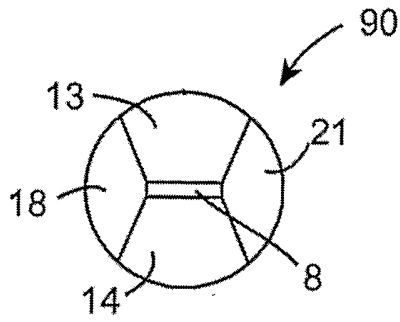

Fig. 23

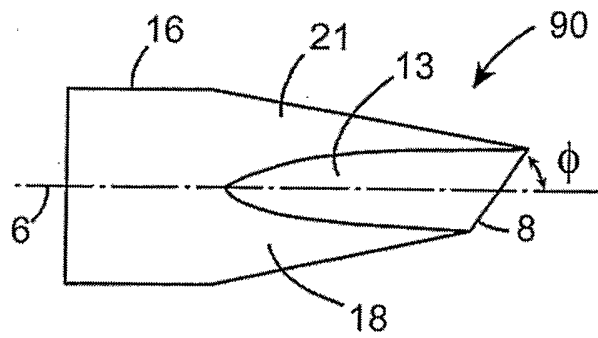

Fig. 22

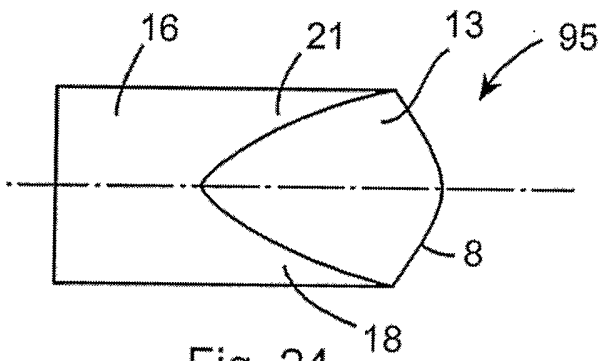

Fig. 24

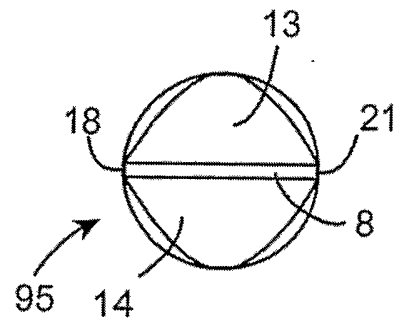

Fig. 25

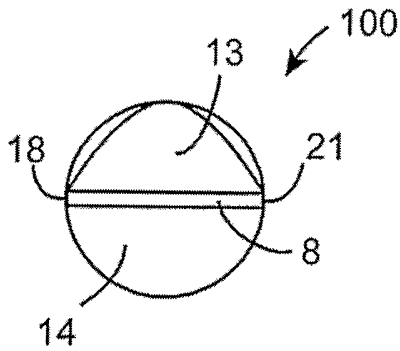

Fig. 27

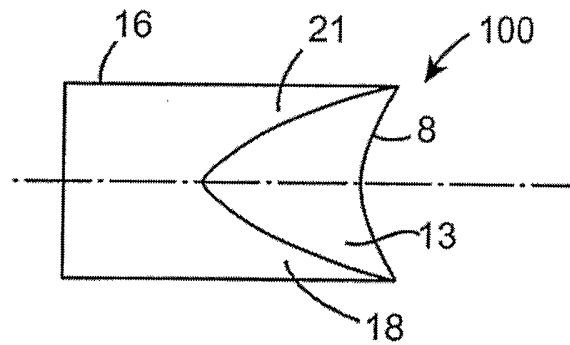

Fig. 26

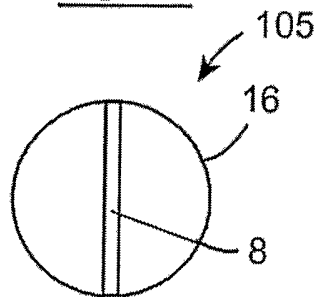

Fig. 29

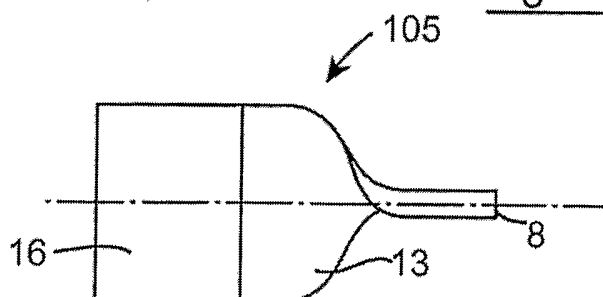

Fig. 28

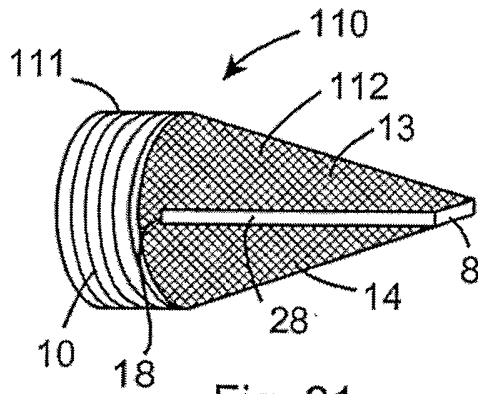

Fig. 31

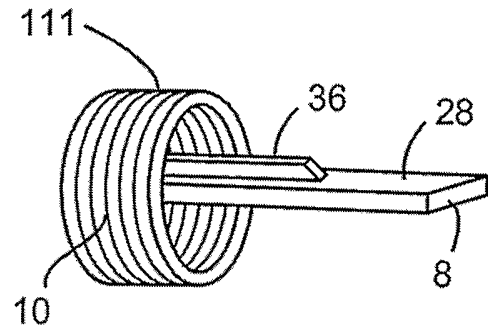

Fig. 32

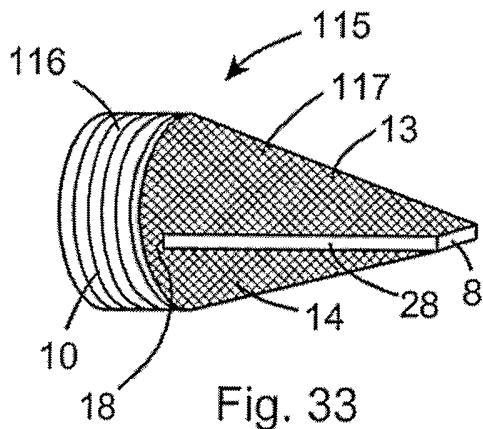

Fig. 33

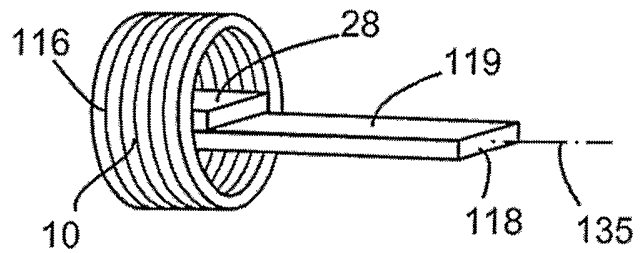

Fig. 34

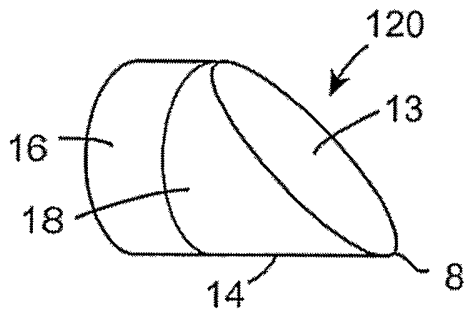

Fig. 35

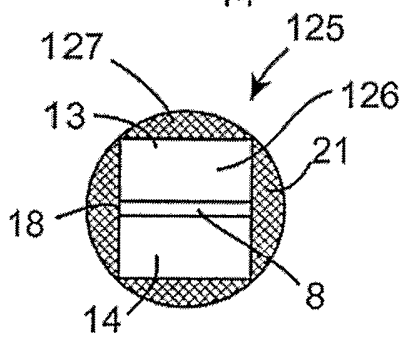

Fig. 37

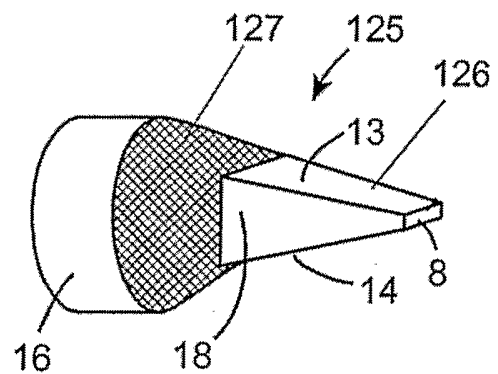

Fig. 36

## INTERNATIONAL SEARCH REPORT

International Application No  
PCT/IE2005/000031A. CLASSIFICATION OF SUBJECT MATTER  
IPC 7 A61M25/01 A61M25/00

According to International Patent Classification (IPC) or to both national classification and IPC

## B. FIELDS SEARCHED

Minimum documentation searched (classification system followed by classification symbols)  
IPC 7 A61M

Documentation searched other than minimum documentation to the extent that such documents are included in the fields searched

Electronic data base consulted during the international search (name of data base and, where practical, search terms used)

EPO-Internal

## C. DOCUMENTS CONSIDERED TO BE RELEVANT

Category °	Citation of document, with indication, where appropriate, of the relevant passages	Relevant to claim No.
X	US 2003/013993 A1 (JAFARI MO ET AL) 16 January 2003 (2003-01-16)  paragraphs '0021! - '0033!; ----- -/--	1-5, 7-9, 16, 17, 24-30, 32-36, 38, 40-43, 45, 46, 51-59, 61, 66

 Further documents are listed in the continuation of box C. Patent family members are listed in annex.

° Special categories of cited documents :

"A" document defining the general state of the art which is not considered to be of particular relevance

"E" earlier document but published on or after the international filing date

"L" document which may throw doubts on priority claim(s) or which is cited to establish the publication date of another citation or other special reason (as specified)

"O" document referring to an oral disclosure, use, exhibition or other means

"P" document published prior to the international filing date but later than the priority date claimed

"T" later document published after the international filing date or priority date and not in conflict with the application but cited to understand the principle or theory underlying the invention

"X" document of particular relevance; the claimed invention cannot be considered novel or cannot be considered to involve an inventive step when the document is taken alone

"Y" document of particular relevance; the claimed invention cannot be considered to involve an inventive step when the document is combined with one or more other such documents, such combination being obvious to a person skilled in the art.

"&" document member of the same patent family

Date of the actual completion of the international search

3 June 2005

Date of mailing of the international search report

15/06/2005

Name and mailing address of the ISA  
European Patent Office, P.B. 5818 Patentlaan 2  
NL - 2280 HV Rijswijk  
Tel. (+31-70) 340-2040, Tx. 31 651 epo nl,  
Fax: (+31-70) 340-3016

Authorized officer

Vänttinen, H

## INTERNATIONAL SEARCH REPORT

International Application No

PCT/IE2005/000031

C.(Continuation) DOCUMENTS CONSIDERED TO BE RELEVANT		
Category °	Citation of document, with indication, where appropriate, of the relevant passages	Relevant to claim No.
X	US 5 365 942 A (SHANK ET AL) 22 November 1994 (1994-11-22)  column 5, paragraph 2 - column 6, paragraph 1; figures 4-8 -----	1,8,9, 16,17, 24-30, 48, 50-57, 60,62, 67-70
X	WO 92/08510 A (BOSTON SCIENTIFIC CORPORATION) 29 May 1992 (1992-05-29)  page 5, line 33 - page 14, line 27; figures -----	1,8,10, 13,16, 19,21,55
X	US 6 235 007 B1 (DIVINO, JR. VINCENT ET AL) 22 May 2001 (2001-05-22)  column 3, line 53 - column 8, line 29; figures -----	1,55, 67-70, 72-77
X	WO 98/42399 A (RADIUS MEDICAL TECHNOLOGIES, INC) 1 October 1998 (1998-10-01) page 5, line 16 - page 8, last line ; figures -----	1,55, 67-70, 72-77
X	FR 1 465 723 A (SOCIETE GENERALE DE CONSTRUCTIONS ELECTRIQUES ET MECANIQUES) 30 March 1967 (1967-03-30) the whole document -----	1,78-82
X	US 3 674 014 A (HANS TILLANDER) 4 July 1972 (1972-07-04) the whole document -----	1,78-82
A	US 6 522 909 B1 (GARIBALDI JEFFREY M ET AL) 18 February 2003 (2003-02-18) the whole document -----	1,78-82

# INTERNATIONAL SEARCH REPORT

International application No.  
PCT/IE2005/000031

## Box II Observations where certain claims were found unsearchable (Continuation of item 2 of first sheet)

This International Search Report has not been established in respect of certain claims under Article 17(2)(a) for the following reasons:

1.  Claims Nos.: 83-86  
because they relate to subject matter not required to be searched by this Authority, namely:  
Rule 39.1(iv) PCT - Method for treatment of the human or animal body by surgery
2.  Claims Nos.:  
because they relate to parts of the International Application that do not comply with the prescribed requirements to such an extent that no meaningful International Search can be carried out, specifically:
3.  Claims Nos.:  
because they are dependent claims and are not drafted in accordance with the second and third sentences of Rule 6.4(a).

## Box III Observations where unity of invention is lacking (Continuation of item 3 of first sheet)

This International Searching Authority found multiple inventions in this international application, as follows:

1.  As all required additional search fees were timely paid by the applicant, this International Search Report covers all searchable claims.
2.  As all searchable claims could be searched without effort justifying an additional fee, this Authority did not invite payment of any additional fee.
3.  As only some of the required additional search fees were timely paid by the applicant, this International Search Report covers only those claims for which fees were paid, specifically claims Nos.:
4.  No required additional search fees were timely paid by the applicant. Consequently, this International Search Report is restricted to the invention first mentioned in the claims; it is covered by claims Nos.:

### Remark on Protest

- The additional search fees were accompanied by the applicant's protest.
- No protest accompanied the payment of additional search fees.

## INTERNATIONAL SEARCH REPORT

Information on patent family members

International Application No

PCT/IE2005/000031

Patent document cited in search report		Publication date	Patent family member(s)	Publication date
US 2003013993	A1	16-01-2003	US 6464650 B2	15-10-2002
			AU 2484700 A	24-07-2000
			WO 0040288 A1	13-07-2000
			US 6491648 B1	10-12-2002
US 5365942	A	22-11-1994	US 5147317 A	15-09-1992
			US RE37148 E1	24-04-2001
			JP 2575238 B2	22-01-1997
			JP 4231071 A	19-08-1992
			CA 2056873 A1	04-06-1992
			EP 0495299 A1	22-07-1992
			JP 4292175 A	16-10-1992
WO 9208510	A	29-05-1992	CA 2095814 A1	10-05-1992
			DE 69124395 D1	06-03-1997
			DE 69124395 T2	28-08-1997
			EP 0556316 A1	25-08-1993
			ES 2098489 T3	01-05-1997
			JP 6505646 T	30-06-1994
			US 5303714 A	19-04-1994
			US 5385152 A	31-01-1995
			WO 9208510 A1	29-05-1992
			US 6235007	B1
US 5797876 A	25-08-1998			
AU 4335399 A	20-12-1999			
DE 69924487 D1	04-05-2005			
EP 1083958 A2	21-03-2001			
JP 2002516728 T	11-06-2002			
WO 9962584 A2	09-12-1999			
US 2002040232 A1	04-04-2002			
AU 714589 B2	06-01-2000			
AU 3500297 A	14-01-1998			
CA 2258966 A1	31-12-1997			
EP 0917479 A1	26-05-1999			
JP 2001500751 T	23-01-2001			
WO 9749447 A1	31-12-1997			
US 6123698 A	26-09-2000			
AU 1145597 A	19-06-1997			
CA 2238861 A1	05-06-1997			
DE 69632483 D1	17-06-2004			
DE 69632483 T2	12-05-2005			
EP 0874658 A2	04-11-1998			
JP 2000501010 T	02-02-2000			
WO 9719713 A2	05-06-1997			
US 5976119 A	02-11-1999			
ZA 9609961 A	17-06-1997			
WO 9842399	A	01-10-1998	US 5885227 A	23-03-1999
			AU 6561598 A	20-10-1998
			WO 9842399 A1	01-10-1998
FR 1465723	A	30-03-1967	NONE	
US 3674014	A	04-07-1972	SE 336642 B	12-07-1971
			CH 521759 A	30-04-1972
			DE 2044368 A1	06-05-1971
			DK 124171 B	25-09-1972

# INTERNATIONAL SEARCH REPORT

information on patent family members

International Application No

PCT/IE2005/000031

Patent document cited in search report	Publication date	Patent family member(s)	Publication date
US 3674014      A		GB      1283453 A	26-07-1972
		JP      48015111 B	12-05-1973
		NL      7015449 A	03-05-1971
		NO      123499 B	29-11-1971
US 6522909      B1	18-02-2003	US      2004030244 A1	12-02-2004
		AU      5548299 A	28-02-2000
		EP      1115327 A2	18-07-2001
		WO      0007641 A2	17-02-2000
		US      6315709 B1	13-11-2001