



(11) **EP 2 853 813 B1**

(12) **EUROPEAN PATENT SPECIFICATION**

(45) Date of publication and mention of the grant of the patent:
26.10.2016 Bulletin 2016/43

(51) Int Cl.:
F23D 14/22 (2006.01) **F23D 14/06** (2006.01)
F23D 14/58 (2006.01) **F23D 23/00** (2006.01)

(21) Application number: **13466023.2**

(22) Date of filing: **30.09.2013**

(54) **Burner head**

Brennerkopf

Tête de brûleur

(84) Designated Contracting States:
AL AT BE BG CH CY CZ DE DK EE ES FI FR GB GR HR HU IE IS IT LI LT LU LV MC MK MT NL NO PL PT RO RS SE SI SK SM TR

(43) Date of publication of application:
01.04.2015 Bulletin 2015/14

(73) Proprietor: **Vysoké Učení Technické V Brno**
690 01 Brno (CZ)

(72) Inventors:
• **Skryja, Pavel**
58827 Rybne (CZ)
• **Jurena, Tomas**
74706 Opava (CZ)
• **Stehlik, Petr**
61600 Brno (CZ)

- **Belohradsky, Petr**
66441 Popuvky (CZ)
- **Hajek, Jiri**
616 00 Brno - Kralovo Pole (CZ)
- **Tabasova, Andrea**
98055 Klenovec (CZ)
- **Nejezchleb, Radek**
67905 Krtiny (CZ)

(74) Representative: **Malusek, Jiri**
Mendlovo namesti 1 a
603 00 Brno (CZ)

(56) References cited:
JP-A- H08 178 224 JP-A- 2008 111 591
US-A- 5 660 045

EP 2 853 813 B1

Note: Within nine months of the publication of the mention of the grant of the European patent in the European Patent Bulletin, any person may give notice to the European Patent Office of opposition to that patent, in accordance with the Implementing Regulations. Notice of opposition shall not be deemed to have been filed until the opposition fee has been paid. (Art. 99(1) European Patent Convention).

DescriptionField of the invention

[0001] The invention relates to a burner head formed on the primary portion of a gas burner in which gases having different calorific values will be burnt.

Background of the invention

[0002] Gases are commonly burnt by means of gas burner heads and nozzles having diverse constructional arrangements. Such burner heads or nozzles are mostly designed to burn a particular noble gaseous fuel. Besides that, such burner heads do not enable non-noble gases to be burnt, such as by-products from chemical and processing industries or gases originating from alternative sources (e.g. biogas, landfill gas or the like). In most cases, such gases are waste products having low and variable calorific values. Common gas burner heads are not able to ensure a sufficient stability of the burning process when lean gases are burnt and an oversupply of combustion air cannot be avoided. Frequent changes to the combustion conditions, such as varying pressure ratios inside a combustion chamber, cause the flame to extinguish, thus giving rise to hazardous situations. Typical examples include plants operating in a charge mode, waste incineration plants and the like.

[0003] Document JPH081781224 discloses a burner head according to the preamble of claim 1.

[0004] In JP2008111591 burner head is presented formed by a hollow cylindrical welded-on piece, the bottom internal circumference of the welded-on piece being welded to the outer burner feed pipe and the top internal circumference of the being welded to the inner burner feed pipe, the head being provided with the power nozzles arranged in the area of the bevelled front face.

[0005] In US 5, 660, 045 burner head is presented and with the annular flame catcher on the top outlet from a nozzle having a triangular cross-section with the upper leg perpendicularly adjoining the outer wall of the head and with the hypotenuse extending in a slanting inward and downward direction.

[0006] The objective of the invention is to present a gas burner head which will be able to ensure a sufficient stability of the burning process when lean gases are burnt during an oversupply of combustion air.

Summary of the invention

[0007] The above drawbacks are largely eliminated by a burner head according to claim 1.

Brief description of the drawings

[0008] The invention will be further explained with reference to the accompanying drawing, wherein Fig. 1 shows a gas burner with an inner feed pipe of the first

combustion stage, the end of the pipe being provided with the burner head according to the invention, and Fig. 2 shows the burner head in a detailed view.

5 Preferred embodiment of the invention

[0009] Fig. 1 shows a gas burner with an inner feed pipe of the first combustion stage in a general view, the end of the pipe being provided with the burner head according to the invention. It is evident that the gas burner 1 consists of the gas supply branch 8, which is provided with the flange 9 at the its inlet end, the outlet end of the gas supply branch 8 leading into the gas distributor. The gas distributor 10 is interconnected with the outer burner feed pipe 7 of the first combustion stage by means of the connecting pipe 17. The connecting pipe 17 is attached to the outer burner feed pipe 7 by means of the pipe union 15. Within the combustion area, the outer burner feed pipe 7 is supplemented by the inner burner feed pipe 4 made of a refractory material, the latter being inserted in the former and forming an extension of the same. The inner burner feed pipe 4 is coaxial relative to the outer burner feed pipe 7 of the first combustion stage. The common end of the burner feed pipes 4, 7 carries the burner head 22 which is formed by a hollow cylindrical welded-on piece, the bottom internal circumference of the welded-on piece being welded to the outer burner feed pipe 7 and the top internal circumference of the being welded to the inner burner feed pipe 4.

[0010] Either end of the connecting pipe 17 is provided by one pipe union 15, the first of the latter being connected to the primary gas distributor 10 and the second one being connected to the welded-one branch 14, in which the nozzle 21 for restricting the flow of gas supplied to the burner head 22 is arranged. Furthermore, the feed pipes 12 of the second combustion stage are visible, which are connected to the respective pipe of the gas distributor 10 by means of the pipe union 11. Thus, the gas distributor 10 is provided with one inlet formed by the gas supply branch 8, one outlet leading to the first gas stage and formed by the connecting pipe 17 and three outlets leading to the second gas stage and formed by the feed pipes 12, of which only one is visible in Fig. 1.

[0011] The feed pipes 12 of the second combustion stage are terminated by the secondary nozzles 13 which are fixed in their position by means of the respective lock nuts (not shown).

[0012] The gas distributor 10 is attached to the inner burner feed pipe 4 of the first combustion stage. The entire gas burner 1 is welded to the cover 6 which is shown in a partial view in Fig. 1. The cover 6 is, in turn, attached to an air box by means of the respective threaded coupling member (not shown). The cover is provided with the gasket 18, with the insulating member 19, with the holder 16 for the insulating member and with the refractory caulking compound 20.

[0013] Fig. 2 is a detailed view showing the burner head 22 on a primary burner. The burner head is formed by a

welded-on piece attached to the burner feed pipes 4 and 7 and provided with the power nozzles 3 arranged in the area of the bevelled front face 25, with the stabilizing nozzles 5 arranged underneath the power nozzles and formed in the cylindrical wall and with the flame catcher 21 arranged underneath the stabilizing nozzles 5 and extending from the outer wall of the head 22, the flame catcher having a triangular cross-section with the upper leg 24 perpendicularly adjoining the outer wall of the head 22 and with the hypotenuse 23 extending in a slanting inward and downward direction.

[0014] The burner head 22 itself and the flame catcher 21 have 80 mm and 100 mm in diameter, respectively. These diametric dimensions are important with respect to the necessity of ensuring a sufficient stability of the flame in the area of the stabilizing nozzles 5. In the latter area, a considerable decrease of the turbulent flow and an increase of the backflow of the combustion air occur. The stabilizing nozzles 5 are suitably arranged between the flame catcher 21 and the front face of the burner head 22 and are formed by bores having their axes inclined at the angle β . Thus, the stabilizing nozzles enable the fuel to be appropriately mixed with the combustion air supplied to serve as oxidizing agent during the combustion process. After having been prepared under the above conditions, the combustible mixture achieves a flow velocity that is lower than the burning velocity. Thus, the flame remains "on the leeward side". In this manner, the flame can get stabilized in the above area. Owing to that, the flame provides a sufficient initiation energy, which is required for igniting the air-fuel mixture, the latter being formed by mixing the gas flowing out of the power nozzles with the combustion air flowing around the burner head. If the flame were not anchored in the area of the flame catcher 21 in the above described manner, it would get torn away from the burner head 22.

[0015] The above described gas burner eliminates the above mentioned unreliable operational properties. The maximum stability of combustion is achieved particularly by means of the constructional arrangement of the head 22 of the primary burner. The desired stability of combustion is achieved by the incorporation of the flame catcher 21 into the gas burner head 22, since the flame catcher creates a turbulent whirling flow in the area of the stabilizing nozzles 5. Such flow is characterized by having a lower velocity downstream the flame catcher 21, thus mitigating turbulences and stabilizing the flame in said area. The above described arrangement enables the gas flowing out of the power nozzles to be reliably ignited. It provides a sufficient initiation energy, which is required for igniting the mixture and stabilizing the combustion process in the area of the power nozzles of the head 22. The gas burner head 22 has an annular shape which enables an auxiliary oil burner or suitable measuring and regulating members to be centrally positioned within the head. The gaseous fuel is supplied to the gas burner head through the annular gap between the burner feed tubes 7 and 4. The flow rate and the pressure of the

gaseous fuel are controlled by means of a restricting orifice which determines the ratio between the primary and secondary portions of the gas burner. Hence, the pressure of the gaseous fuel is lower in the primary portion than in the secondary one which significantly improves the stability of the primary portion and enables higher working pressures and flow rates to be utilized in the secondary portion. This considerably increases the efficiency of mixing the combustion air with the secondary fuel. According to the particular application, the burner head may be provided with 3 or four secondary nozzles. The angular orientation of the secondary nozzles relative to the axis of the burner head enables the tangential discharge of the gas to be achieved in the radial direction.

Claims

1. Burner head formed on a primary portion of a gas burner, the burner head is formed by a hollow cylindrical welded-on piece, the bottom internal circumference of a welded-on piece being welded to an outer burner feed pipe (7) and the top internal circumference of the being welded to the inner burner feed pipe (4), the head (22) being provided with a power nozzles (3) arranged in an area of a bevelled front face (25) and with an annular flame catcher (21) having a triangular cross-section with the upper leg (24) perpendicularly adjoining the outer wall of the head (22) and with a hypotenuse (23) extending in a slanting inward and downward direction, **characterized in that** underneath the the power nozzles (3) stabilizing nozzles (5) are arranged in the cylindrical wall at the angle (β) relative to the same, wherein underneath the stabilizing nozzles (5) the flame catcher (21) is arranged.

Patentansprüche

1. Brennerkopf, der auf dem primären Teil des Gasbrenners angeordnet ist, welcher als ein zylindrischer hohler angeschweisster Stück durchgeführt ist, wobei der untere Innenumfang des angeschweissten Stückes auf die Aussenrohr (7) und der obere Umfang auf die innere Brennerrohr (4) angeschweisst ist, wobei der Brennerkopf (22) im Gebiet des Frontfassetieren (25) mit Hauptdüsen (3) und mit einem Flammenfanger (21) ausgestattet ist, der im lotgerechten Schnitt eine Form des Dreiecks hat, mit einem oberen Schenkel (24), der senkrecht zu der Aussenwand des Brennerkopfes (22) anliegt und der untere Schenkel (23) ist in Richtung schräg-unten orientiert, **dadurch gekennzeichnet, dass** unter den Hauptdüsen (3) Stabilisierungsdüsen (5) in dem zylindrischen Wand unter dem Winkel (β) angeordnet sind, wobei unter den Stabilisierungsdüsen (5) der Flammenfanger (21) angeordnet ist.

Revendications

1. Tete de bruleur, positionée sur une pièce primaire de bruleur a gaz, qui est construite et soudée en forme cylindrique et creuse. L'arrondissement inférieur a l'intérieur d'une pièce soudée est soudé sur une tube de bruleur externe (7), et en meme temps est l'arrondissement supérieur a l'intérieur soudé sur une tube de bruleur interne (4). Tete (22) possède en endroit de crispation frontale (25) des tyuères de puissance (3) et accroche- flamme (21), qui a en coupe verticale une forme d'un triangle. Son bras (cathéte) supérieur (24) touche perpendiculairement coté externe du tete (22) et bras (cathéte) inférieur (23) est orienté obliquement vers bas. Tete de bruleur est **caractérisé en ce qu'**au dessous de tuyères puissantes (3) sont rangées des tuyères de stabilisation (5) en coté cylindrique en angle de (beta). Au dessous de tuyères de stabilisation (5) est rangé un accroche-flamme (21).

5

10

15

20

25

30

35

40

45

50

55

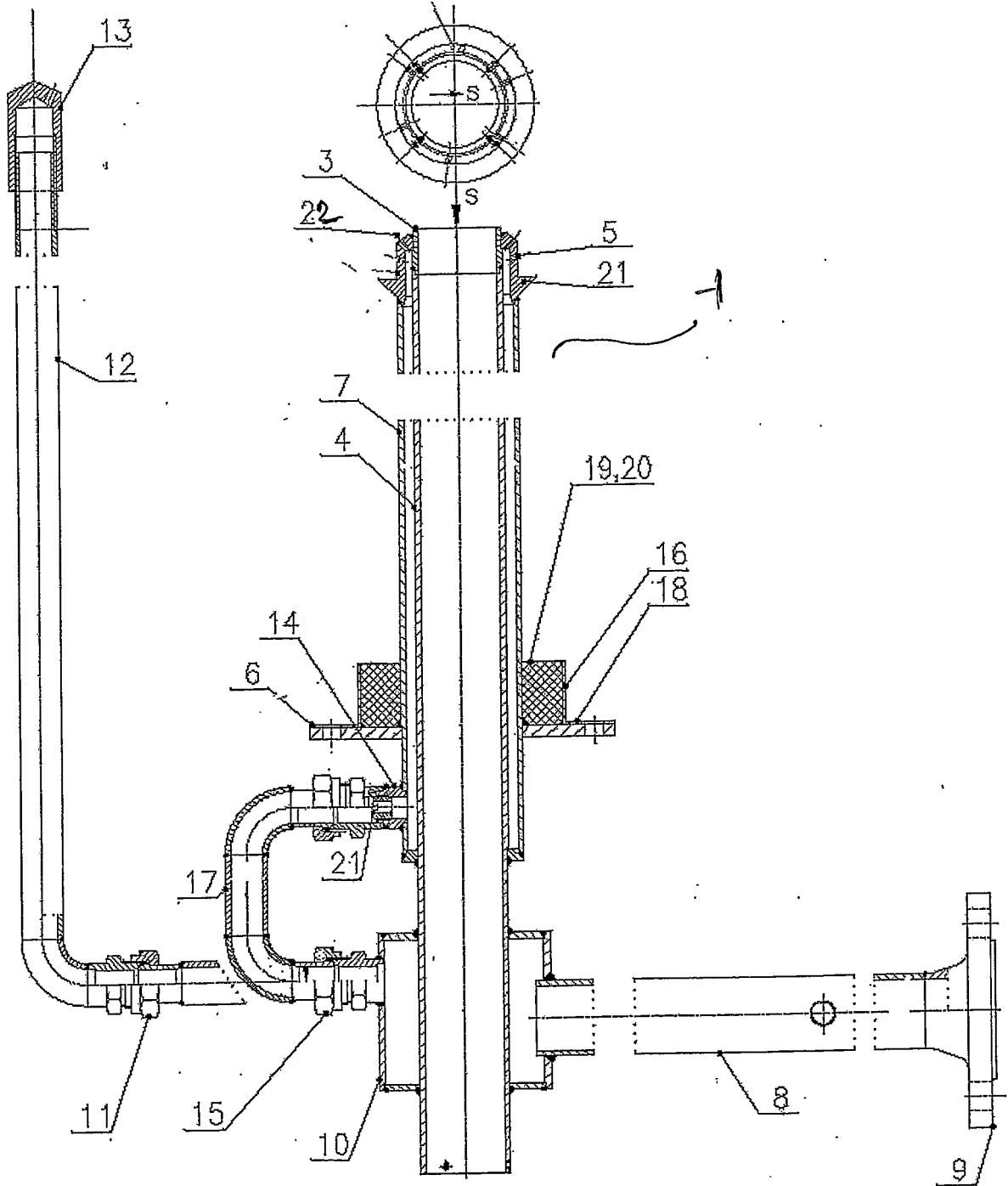

Fig.1

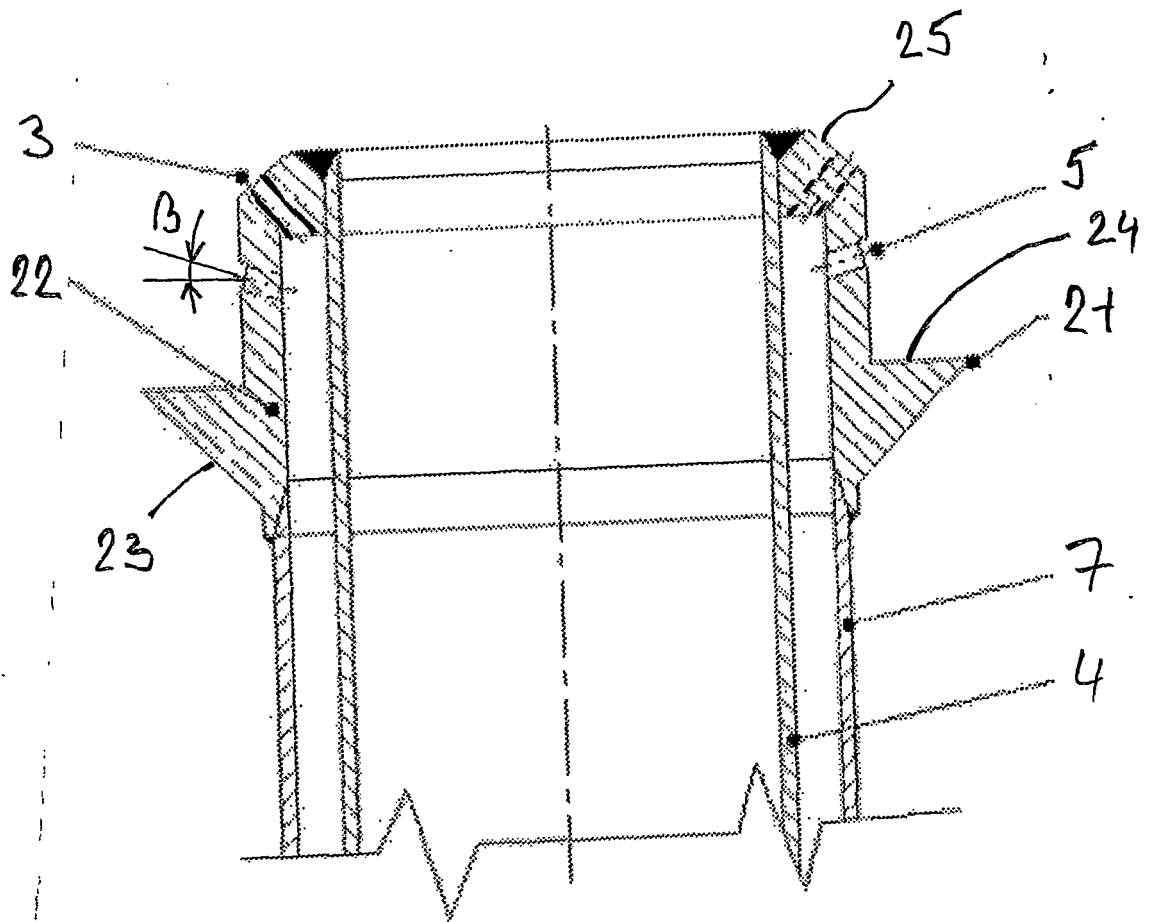

Fig.2

REFERENCES CITED IN THE DESCRIPTION

This list of references cited by the applicant is for the reader's convenience only. It does not form part of the European patent document. Even though great care has been taken in compiling the references, errors or omissions cannot be excluded and the EPO disclaims all liability in this regard.

Patent documents cited in the description

- JP H081781224 B [0003]
- JP 2008111591 B [0004]
- US 5660045 A [0005]