



(43) International Publication Date  
8 September 2017 (08.09.2017)

- (51) International Patent Classification:  
A47J 37/07 (2006.01)
- (21) International Application Number:  
PCT/US2017/019037
- (22) International Filing Date:  
23 February 2017 (23.02.2017)
- (25) Filing Language: English
- (26) Publication Language: English
- (30) Priority Data:  
62/301,793 1 March 2016 (01.03.2016) US
- (71) Applicant: SPECTRUM BRANDS, INC. [US/US]; 3001  
Deming Way, Middleton, Wisconsin 53562 (US).
- (72) Inventors: SMITH, Jacob Daniel; 6113 Winnequah  
Road, Monona, Wisconsin 53716 (US). GUCKENBER-  
GER, Matthew; W1456 Highway O, Oconomowoc, Wis-  
consin 53066 (US).
- (74) Agents: JIMENEZ, Jose, W. et al.; Kagan Binder, PLLC,  
Suite 200, Maple Island Building, 221 Main Street North,  
Stillwater, Minnesota 55082 (US).

(81) Designated States (unless otherwise indicated, for every  
kind of national protection available): AE, AG, AL, AM,  
AO, AT, AU, AZ, BA, BB, BG, BH, BN, BR, BW, BY,  
BZ, CA, CH, CL, CN, CO, CR, CU, CZ, DE, DJ, DK, DM,  
DO, DZ, EC, EE, EG, ES, FI, GB, GD, GE, GH, GM, GT,  
HN, HR, HU, ID, IL, IN, IR, IS, JP, KE, KG, KH, KN,  
KP, KR, KW, KZ, LA, LC, LK, LR, LS, LU, LY, MA,  
MD, ME, MG, MK, MN, MW, MX, MY, MZ, NA, NG,  
NI, NO, NZ, OM, PA, PE, PG, PH, PL, PT, QA, RO, RS,  
RU, RW, SA, SC, SD, SE, SG, SK, SL, SM, ST, SV, SY,  
TH, TJ, TM, TN, TR, TT, TZ, UA, UG, US, UZ, VC, VN,  
ZA, ZM, ZW.

(84) Designated States (unless otherwise indicated, for every  
kind of regional protection available): ARIPO (BW, GH,  
GM, KE, LR, LS, MW, MZ, NA, RW, SD, SL, ST, SZ,  
TZ, UG, ZM, ZW), Eurasian (AM, AZ, BY, KG, KZ, RU,  
TJ, TM), European (AL, AT, BE, BG, CH, CY, CZ, DE,  
DK, EE, ES, FI, FR, GB, GR, HR, HU, IE, IS, IT, LT, LU,  
LV, MC, MK, MT, NL, NO, PL, PT, RO, RS, SE, SI, SK,  
SM, TR), OAPI (BF, BJ, CF, CG, CI, CM, GA, GN, GQ,  
GW, KM, ML, MR, NE, SN, TD, TG).

Published:

— with international search report (Art. 21(3))

(54) Title: BONFIRE GRILLING APPLIANCE

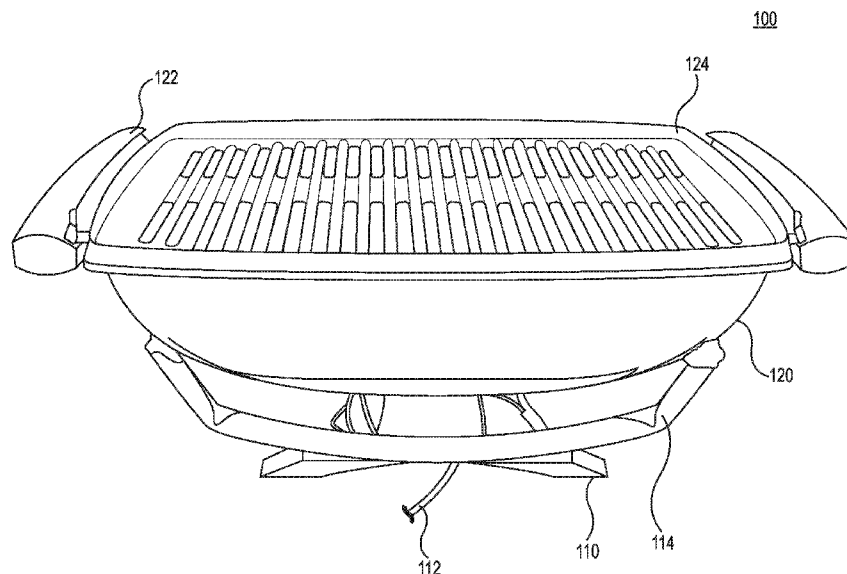

Fig. 1A

(57) Abstract: There is provided an indoor/outdoor tabletop grill appliance which uses quartz halogen tubes as radiant heating elements to provide cooking functionality combined with the aesthetics of the outdoor grilling experience. The invention provides the advantage of various forms of cooking that also speed up the cooking process: direct heat on the food item from the quartz halogen tubes, heat reflected back from the inner surfaces of the grilling chamber and onto the food item, convection heat directed about the food item due to the grilling chamber configuration and directed heat from the slotted platen this in contact with the food item received from the halogen tubes.



WO 2017/151374 A1

## BONFIRE GRILLING APPLIANCE

### CLAIM OF PRIORITY

**[0001]** This application claims priority to and the benefit of a U.S. Provisional Application with serial number 62/301,793, filed on March 1, 2016, which is incorporated herein by reference in its entirety.

### FIELD AND BACKGROUND OF THE INVENTION

**[0002]** The invention described herein relates generally to table top grills for indoor or outdoor use.

**[0003]** Various types of cooking apparatus are known including barbeques, and gas and electric tabletop grilling appliances. Some indoor tabletop grills have a natural gas burner or electric heating element positioned under a grilling sheet. In some models, an exhaust system is provided adjacent (e.g., above or behind the grill) to exhaust the combustion gasses and smoke emanating from foods being cooked. These indoor barbeques or tabletop grilling appliances have several disadvantages including a connection to a pressurized propane tank or canister; a noisy exhaust system that may be needed to vent out the smoke; difficulty in accurately controlling electric heating elements when it comes to cooking temperature; and weight and lack of portability for some models.

**[0004]** Existing tabletop models use electric resistance heating placed under a platen or a corrugated cooking surface which makes it difficult to clean since other food particles and grease may collect while the food item is cooking. Such cooking appliances attempt to simulate the taste and look of barbequed food but have not been very successful. There is a need for a tabletop cooking grill appliance that addresses the shortcomings of the market.

## SUMMARY

**[0005]** In various example embodiments, a design for an indoor/outdoor grill is provided which uses quartz halogen tube heaters to provide cooking functionality combined with the aesthetics of the grilling experience, resulting in food which better resembles current outdoor grills. Further, the invention provides the advantage of various forms of cooking that also speed up the cooking process: direct heat on the food item from the quartz halogen tubes, heat reflected back from the inner surfaces of the grilling chamber and onto the food item, convection heat directed about the food item due to the grilling chamber configuration and directed heat from the slotted platen this in contact with the food item received from the halogen tubes.

**[0006]** In one example embodiment, a new indoor/outdoor tabletop grilling appliance is provided that uses one or more quartz tubes to heat up quicker and hotter than current electric grills on the market with all of the components housed in a barbeque-style grill. In addition, by using a slotted platen or grilling plate the infrared (IR) emitted by the quartz or halogen tubes is allowed to aid in cooking foods placed on the grill. This same IR emission provides a visual glow and warmth to the grill that replicates current outdoor grills as well as providing a visual feedback for heat intensity. The design provided herein intends to capture the benefits of convection and radiant heat from the quartz tubes as well as direct heat via heating the slotted grill plate, thereby providing a very efficient and fast grilling experience. In addition, with the use of an appropriate temperature and electric controller the heat intensity from the halogen tubes will be variable (which will also be visually apparent) and will provide a pleasant charcoal-like glow.

**[0007]** In a related example embodiment, a tabletop grill for cooking food is provided that includes a grilling chamber having a highly reflective and low heat absorption inner surface for reflecting radiant energy to a food

item positioned therein, the grilling chamber being configured to direct emitted radiant energy in a convection manner about the food item. The grill further includes a radiant energy generating assembly emitting a substantial portion of energy in the visible light range of the electromagnetic spectrum, the radiant energy assembly being positioned within the grilling chamber to direct radiant energy at the food item, the food item receiving reflected radiant energy from the inner surface of the grilling chamber and being subjected to convection heat from the emitted radiant energy. Also included is a grill member for supporting the food item that is disposed within the grilling chamber, the grill member being formed of heat conducting material that emits direct heat energy absorbed from the radiant energy assembly to the food item when in contact with the food item. In a related embodiment, the grill further includes a temperature control device to control the radiant energy assembly for controlling radiant and visible light emitted by the radiant energy assembly. In a specific embodiment, the temperature control device controls radiant and visible light emitted by a first quartz halogen tube and by a second quartz halogen tube in one or more of the selected operating states: independent, timed operation, temperature and visual intensity.

**[0008]** In yet another example embodiment, a grill for cooking food is provided that includes a grilling chamber having a highly reflective and low heat absorption inner surface for reflecting radiant energy to a food item positioned therein, the grilling chamber configured to direct emitted radiant energy in a convection manner about the food item. Also included is a radiant energy generating assembly emitting a substantial portion of energy in the visible light range of the electromagnetic spectrum comprised of two quartz halogen tubes mounted in a substantially end to end configuration, the radiant energy assembly positioned within the grilling chamber to direct radiant energy at the food item, the food item receiving reflected radiant energy from the inner surface of the grilling chamber and being subjected to convection heat from the emitted radiant energy. A grill member for supporting the food item is also included that is disposed within the grilling

chamber, the grill member being formed of heat conducting material that emits direct heat energy absorbed from each of the quartz halogen tubes to the food item when the grill member is in contact with the food item. The grill also includes a temperature control device to control the radiant energy assembly for controlling radiant and visible light emitted by the radiant energy assembly.

**[0009]** In another related embodiment, there is provided a method of cooking a food item that includes the steps of configuring a grilling chamber with a highly reflective and low heat absorption inner surface that reflects radiant energy to a food item positioned therein, the grilling chamber configuration forming a convection heating process to speed up the cooking of the food item. The method also includes the step of directing radiant energy generated by a radiant energy assembly substantially in the visible light range of the electromagnetic spectrum at the food item, the food item receiving reflected radiant energy from the inner surface of the grilling chamber and receiving convection heat emitted from the radiant energy assembly. The method includes the step of supporting the food item on a grill member disposed within the grilling chamber formed from a heat conducting material that emits direct heat energy absorbed from the radiant energy assembly to the food item when in contact with the food item and includes controlling a temperature and visible light from the radiant energy assembly to simulate aesthetically an outdoor grilling appearance

**[0010]** The invention now will be described more fully hereinafter with reference to the accompanying drawings, which are intended to be read in conjunction with both this summary, the detailed description and any preferred and/or particular embodiments specifically discussed or otherwise disclosed. This invention may, however, be embodied in many different forms and should not be construed as limited to the embodiments set forth herein; rather, these embodiments are provided by way of illustration only and so that this disclosure will be thorough, complete and will fully convey the full scope of the invention to those skilled in the art.

## DESCRIPTION OF THE DRAWINGS

**[0011]** Other important objects and advantages of the invention will be apparent from the following detailed description of the invention taken in connection with the accompanying drawings in which:

**[0012]** FIGs. 1A-1B illustrate a perspective and top views of a tabletop grilling appliance in accordance with the teachings herein; and

**[0013]** FIGs. 2A-2B illustrate perspective and top views of the tabletop grilling appliance without the slotted platen in accordance with the teachings herein.

## DETAILED DESCRIPTION OF THE INVENTION

**[0014]** Following are more detailed descriptions of various related concepts related to, and embodiments of, methods and apparatus according to the present disclosure. It should be appreciated that various aspects of the subject matter introduced above and discussed in greater detail below may be implemented in any of numerous ways, as the subject matter is not limited to any particular manner of implementation. Examples of specific implementations and applications are provided primarily for illustrative purposes.

**[0015]** The various embodiments of the invention are directed to an indoor/outdoor grill consisting of four major components: a grill base, a cooking surface, a heating element, and a cover. The heating elements are quartz tubes. The tubes are mounted in the grill base. Above the tubes, held by the base, is a slotted plate which acts as the cooking surface. The cooking surface is heated by convection and radiation, both provided by the quartz tubes. The desired food is placed on the cooking surface and the cooking surface is then covered. The food is cooked through conduction by the plate, convection by the heat of the cavity, and direct IR from the element. This provides more effective heating which creates quicker heat up,

higher temperatures, and faster cooking times. Lastly, the light and IR emitted by the quartz tube provide similar aesthetics to current outdoor grills.

**[0016]** Referring now to the figures, FIGs. 1A-1B illustrate a perspective and top views of a tabletop grilling appliance 100 while FIGs. 2A-2B illustrate perspective and top views of tabletop grilling appliance 100 without a slotted platen or grill member in accordance with the teachings herein. In particular, tabletop grill 100 includes a grilling chamber 102 comprised of a top (not shown) and bottom 120 partial enclosures which form the grilling chamber. Bottom or grilling base 120 includes a grill stand 110, handles 122, a power source 112 (a power cord shown), a power conduit 114 that houses power lines to a radiant energy source assembly 128 (Fig. 2B) located within base 120, and a slotted platen or grill member 124 located over base 120 opening. In this example embodiment, base 120 has a highly reflective and low heat absorption inner surface 121 for reflecting radiant energy to a food item 104 positioned therein. Grilling chamber 102 is configured to direct emitted radiant energy in a convection manner about the food item (when the top or cover is on base 120) with radiant energy generating assembly 128 emitting a substantial portion of energy in the visible light range of the electromagnetic spectrum. In this example embodiment, radiant energy assembly 128 is positioned within grilling chamber 102 to direct radiant energy at the food item, the food item receiving reflected radiant energy from inner surface 121 of grilling chamber base 120 and subjected to convection heat from the emitted radiant energy.

**[0017]** Grilling appliance 100, in this example embodiment, also includes a grill member or slotted platen 124 for supporting the food item and is disposed within the grilling chamber (or over the opening of the base). Grill member 124 is formed of heat conducting material that emits direct heat energy absorbed from the radiant energy assembly to the food item when in contact with the food item. Grilling appliance 100 described herein captures the benefits of convection and direct radiant heat from radiant energy assembly 128 as well as direct heat via heating slotted grill plate 124 and

reflected heat from inner surface 121, thereby providing a very efficient and fast grilling experience. Although not shown, grilling appliance 100 includes a temperature controller for controlling radiant energy assembly 128, which is not only for controlling the cooking temperature but also for controlling the visual/light output so as to resemble a traditional grilling experience (such as embers in a charcoal grill or light from flames in a gas grill).

**[0018]** In this example embodiment and referring to FIGs. 2A-2B, radiant energy generating assembly 128 comprises two quartz halogen tube lamps 128A and 128B located in a substantial end to end configuration within grilling base 120. Each of the quartz halogen tubes are connected to a power source via a heat element electrical connector 126 which his then connected to power source 112 covered by a power conduit 114. Although not shown, in this example embodiment, grill appliance 100 includes a temperature control device to control radiant energy assembly 128 for controlling radiant and visible light emitted by quartz halogen tubes 128A and 128B. The temperature control device controls the radiant and visible light emitted by first quartz halogen tube 128A and by second quartz halogen tube 128B, thereby allowing a user to select one or more operating states for each of the tubes: individual independent operation, timed operation, desired temperature and desired visual intensity.

**[0019]** In a related embodiment, radiant energy generating assembly 128 includes a quartz halogen tube lamp 128A which is configurable to extend the length of the grill base (not shown). In a related embodiment, radiant energy assembly 128 includes a quartz body tungsten lamp. The lamps are generally any of the quartz body, tungsten-halogen or high intensity discharge lamps commercially available, e.g., 1 KW, 120 VAC quartz-halogen lamps, which are about 7 to 7.5 inches long and cook with approximately fifty percent (50%) of the energy in the visible and near-visible light portion of the spectrum at full lamp power, and that can run off a 15 amp outlet. In the example embodiments described herein, the inner surface of the grilling chamber comprises a low heat and light absorption and highly

reflective coating. In FIG. 2B, the inner surface of the grilling chamber includes a highly light reflective assembly 130A and 130B located under halogen tubes 128A and 128B, respectively. In a related embodiment, the highly reflective member(s) is configured to capture food particles falling from the grill or slotted platen 124. In various embodiments, grilling chamber 102 is selected from the group consisting of a two-piece mating configuration, a clamshell configuration and an enclosure with a front door configuration (similar to a toaster oven).

**[0020]** In a related embodiment, a method of cooking a food item utilizing a radiant energy source and a grilling chamber design that promotes rapid cooking due to the efficient use of the heating energy provided. The method includes configuring a grilling chamber 102 with a highly reflective and low heat absorption inner surface (or assembly) that reflects radiant energy to a food item positioned therein, the grilling chamber configuration forming a convection heating process to speed up the cooking of the food item. The method also includes directing radiant energy generated by a radiant energy assembly 128 substantially in the visible light range of the electromagnetic spectrum at the food item, the food item receiving reflected radiant energy from the inner surface of the grilling chamber and receiving convection heat emitted from the radiant energy assembly 128. The method further includes supporting the food item on a grill member or slotted platen 124 disposed within grilling chamber base 120 formed from a heat conducting material that emits direct heat energy absorbed from radiant energy assembly 128 to the food item when in contact with the food item. The method furthermore includes controlling a temperature and visible light from the radiant energy assembly to simulate aesthetically an outdoor grilling appearance.

**[0021]** In a typical bonfire, the color of the flames can range from White/Yellow (very hot), which is visible to the human at about 570nm; to Orange (hot) and visible to the human at about 590nm; down to Red (warm) which is visible from about 650nm-690nm. These various colors can have

the following actual heat temperatures emanating from the quart halogen tube(s) while cooking: Red: Just visible: 525 °C (980 °F); Dull: 700 °C (1,300 °F); Cherry, dull: 800 °C (1,500 °F); Cherry, full: 900 °C (1,700 °F); and Cherry, clear: 1,000 °C (1,800 °F). Orange: Deep: 1,100 °C (2,000 °F); Clear: 1,200 °C (2,200 °F); and White: Whitish: 1,300 °C (2,400 °F); Bright: 1,400 °C (2,600 °F); Dazzling: 1,500 °C (2,700 °F). Therefore, the tabletop grill, in one example embodiment, includes a controller that allows a user to vary the “heat” by color perceived by the user as when cooking in a bonfire. The controller is programmed such that it correlates the visible color of the “heat” from the quartz tube and power being delivered to the quartz tube (which can include a voltage-varying circuit or variable resistor).

**[0022]** The following patents and publications are incorporated by reference in their entireties: U.S. 4,700,051; 5,517,005; 5,990,454; and 6,369,367.

**[0023]** While the invention has been described above in terms of specific embodiments, it is to be understood that the invention is not limited to these disclosed embodiments. Upon reading the teachings of this disclosure many modifications and other embodiments of the invention will come to mind of those skilled in the art to which this invention pertains, and which are intended to be and are covered by both this disclosure and the appended claims. It is indeed intended that the scope of the invention should be determined by proper interpretation and construction of the appended claims and their legal equivalents, as understood by those of skill in the art relying upon the disclosure in this specification and the attached drawings.

## CLAIMS

What is claimed is:

1. A tabletop grill for cooking food comprising:
  - a grilling chamber having a highly reflective and low heat absorption inner surface for reflecting radiant energy to a food item positioned therein, the grilling chamber configured to direct emitted radiant energy in a convection manner about the food item;
  - a radiant energy generating assembly emitting a substantial portion of energy in the visible light range of the electromagnetic spectrum, the radiant energy assembly positioned within the grilling chamber to direct radiant energy at the food item, the food item receiving reflected radiant energy from the inner surface of the grilling chamber and subjected to convection heat from the emitted radiant energy; and
  - a grill member for supporting the food item and disposed within the grilling chamber, the grill member formed of heat conducting material that emits direct heat energy absorbed from the radiant energy assembly to the food item when in contact with the food item.
2. The grill according to claim 1 wherein the radiant energy generating assembly comprises a quartz halogen tube lamp.
3. The grill according to claim 1 wherein the radiant energy generating assembly comprises two quartz halogen tube lamps located in a substantial end to end configuration.
4. The grill according to claim 1 further comprising a temperature control device to control the radiant energy assembly for controlling radiant and visible light emitted by the radiant energy assembly.
5. The grill according to claim 1 wherein the radiant energy generating assembly comprises a quartz body tungsten lamp.
6. The grill according to claim 1 wherein the inner surface of the grilling chamber comprises a low heat and light absorption and highly reflective coating.

7. The grill according to claim 1 wherein the inner surface of the grilling chamber further comprises a highly light reflective member located under the radiant energy assembly.

8. The grill according to claim 7 wherein the highly reflective member is configured to capture food particles falling from the grill or slotted platen.

9. The grill according to claim 3 further comprising a temperature control device to control the radiant energy assembly for controlling radiant and visible light emitted by a first quartz halogen tube and by a second quartz halogen tube by one or more of the selected operating states: independent, timed operation, temperature and visual intensity.

10. The grill according to claim 1 wherein the grilling chamber is selected from the group consisting of a two-piece mating configuration, a clamshell configuration and an enclosure with a front door configuration.

11. A grill for cooking food comprising:

- a grilling chamber having a highly reflective and low heat absorption inner surface for reflecting radiant energy to a food item positioned therein, the grilling chamber configured to direct emitted radiant energy in a convection manner about the food item;

- a radiant energy generating assembly emitting a substantial portion of energy in the visible light range of the electromagnetic spectrum comprising two quartz halogen tubes mounted in a substantially end to end configuration, the radiant energy assembly positioned within the grilling chamber to direct radiant energy at the food item, the food item receiving reflected radiant energy from the inner surface of the grilling chamber and subjected to convection heat from the emitted radiant energy;

- a grill member for supporting the food item and disposed within the grilling chamber, the grill member formed of heat conducting material that emits direct heat energy absorbed from each of the quartz halogen tubes to the food item when in contact with the food item; and

- a temperature control device to control the radiant energy assembly for controlling radiant and visible light emitted by the radiant energy assembly.

12. The grill according to claim 11 wherein the temperature control device controls each quartz halogen tube so as to provide one or more of the selected operating states: independent, timed operation, temperature and visual intensity.

13. The grill according to claim 12 wherein the inner surface of the grilling chamber comprises a low heat and light absorption and highly reflective coating.

14. The grill according to claim 11 wherein the grilling chamber is selected from the group consisting of a two-piece mating configuration, a clamshell configuration and an enclosure with a front door configuration

15. A method of cooking a food item comprising the steps of:

configuring a grilling chamber with a highly reflective and low heat absorption inner surface that reflects radiant energy to a food item positioned therein, the grilling chamber configuration forming a convection heating process to speed up the cooking of the food item;

directing radiant energy generated by a radiant energy assembly substantially in the visible light range of the electromagnetic spectrum at the food item, the food item receiving reflected radiant energy from the inner surface of the grilling chamber and receiving convection heat emitted from the radiant energy assembly;

supporting the food item on a grill member disposed within the grilling chamber formed from a heat conducting material that emits direct heat energy absorbed from the radiant energy assembly to the food item when in contact with the food item; and

controlling a temperature and visible light from the radiant energy assembly to simulate aesthetically an outdoor grilling appearance.

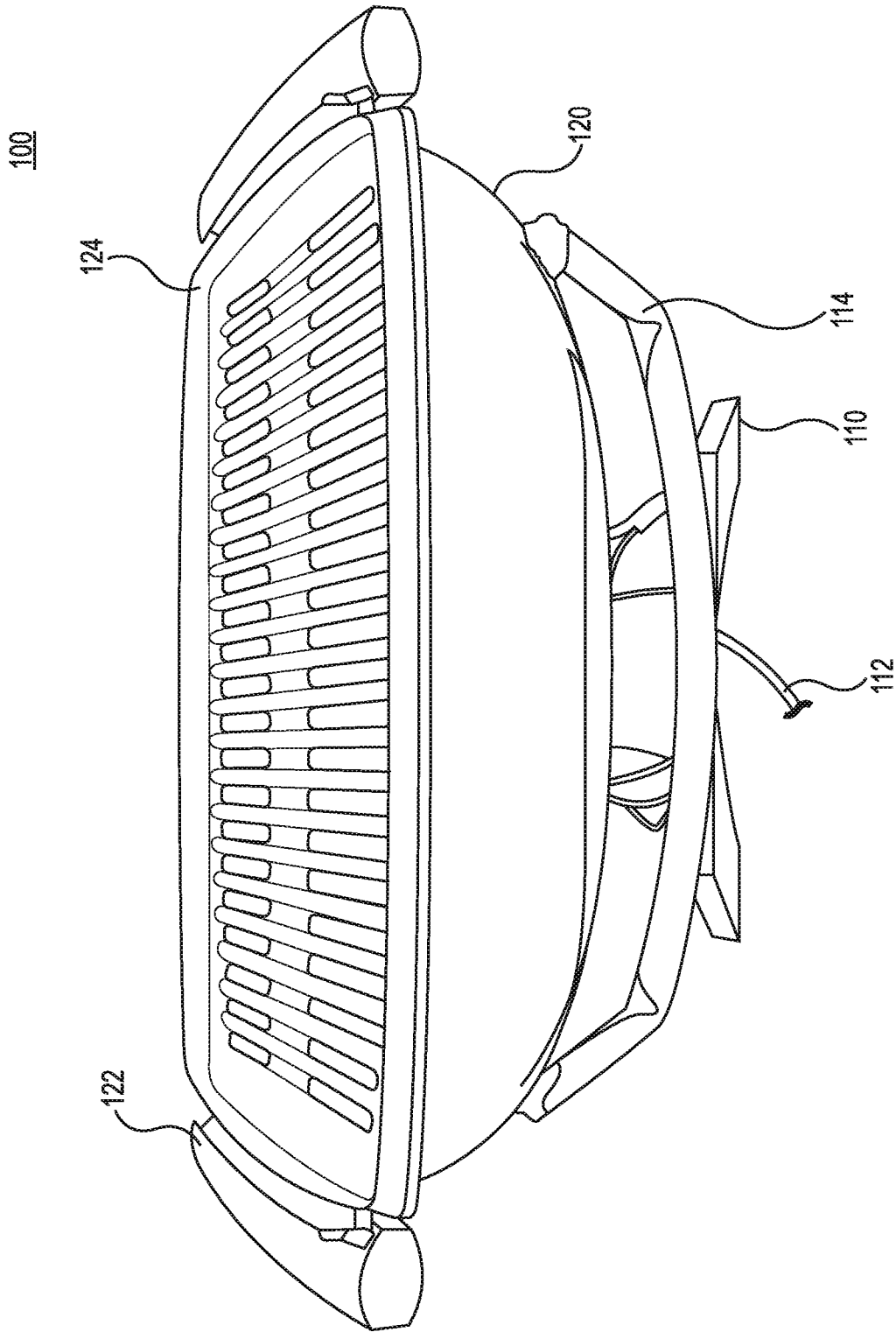

Fig. 1A

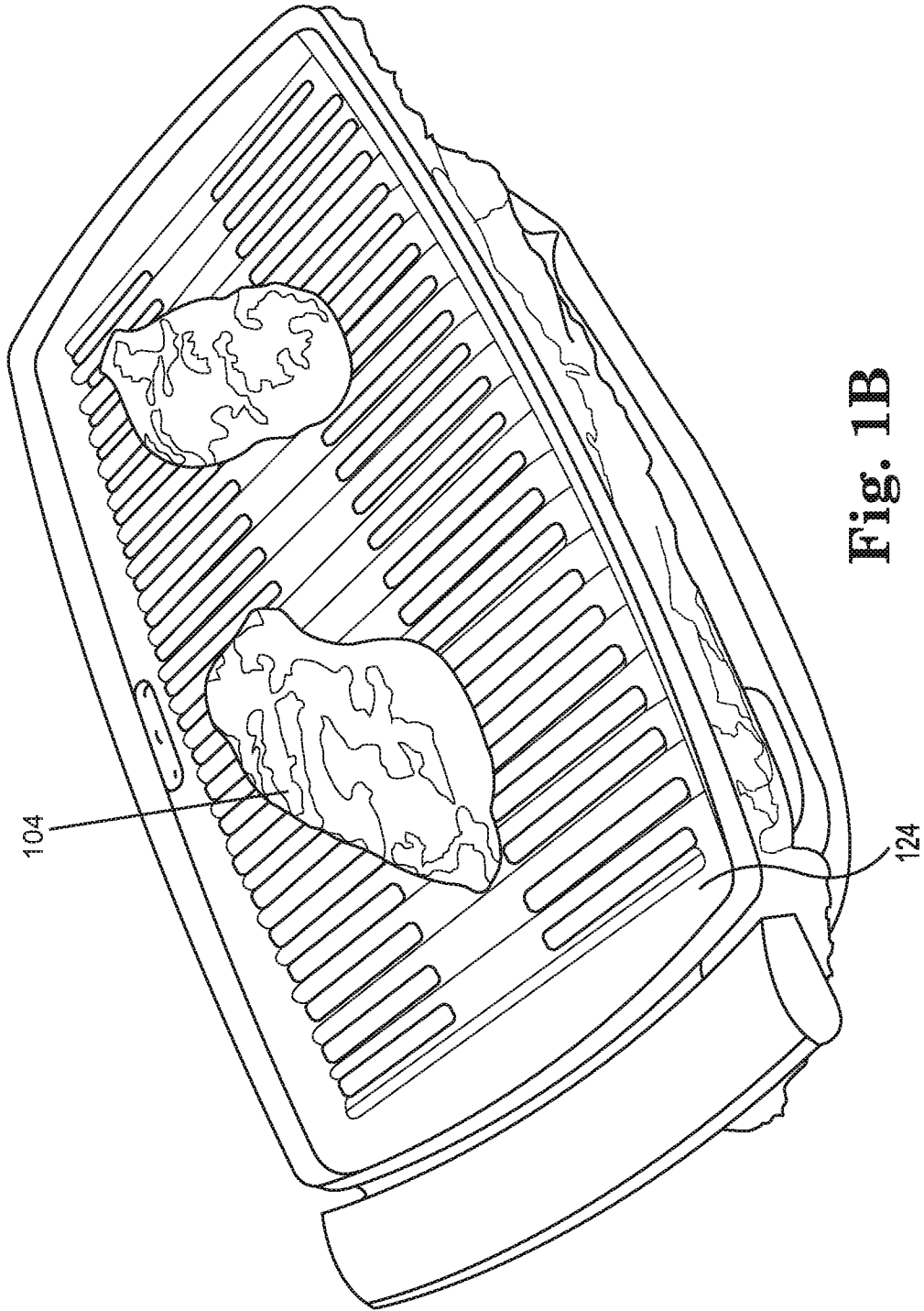

Fig. 1B

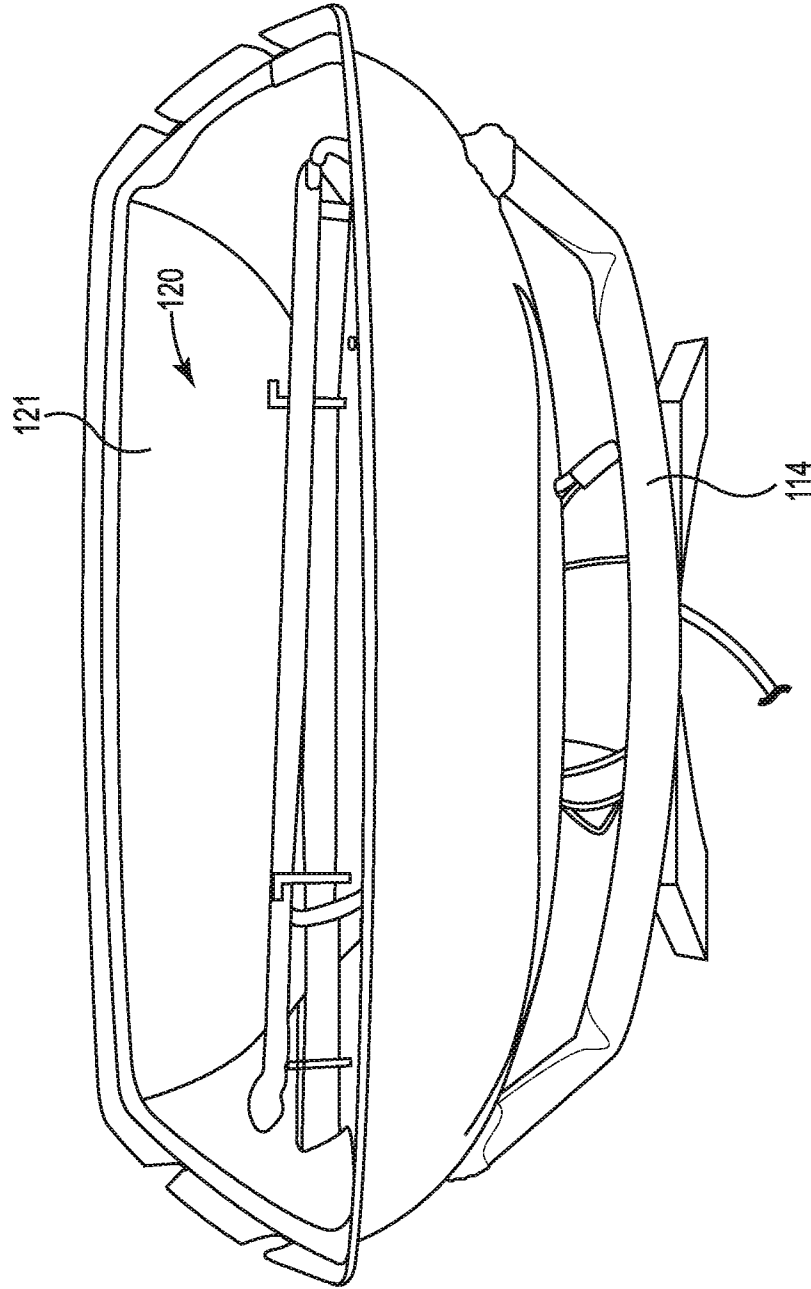

Fig. 2A

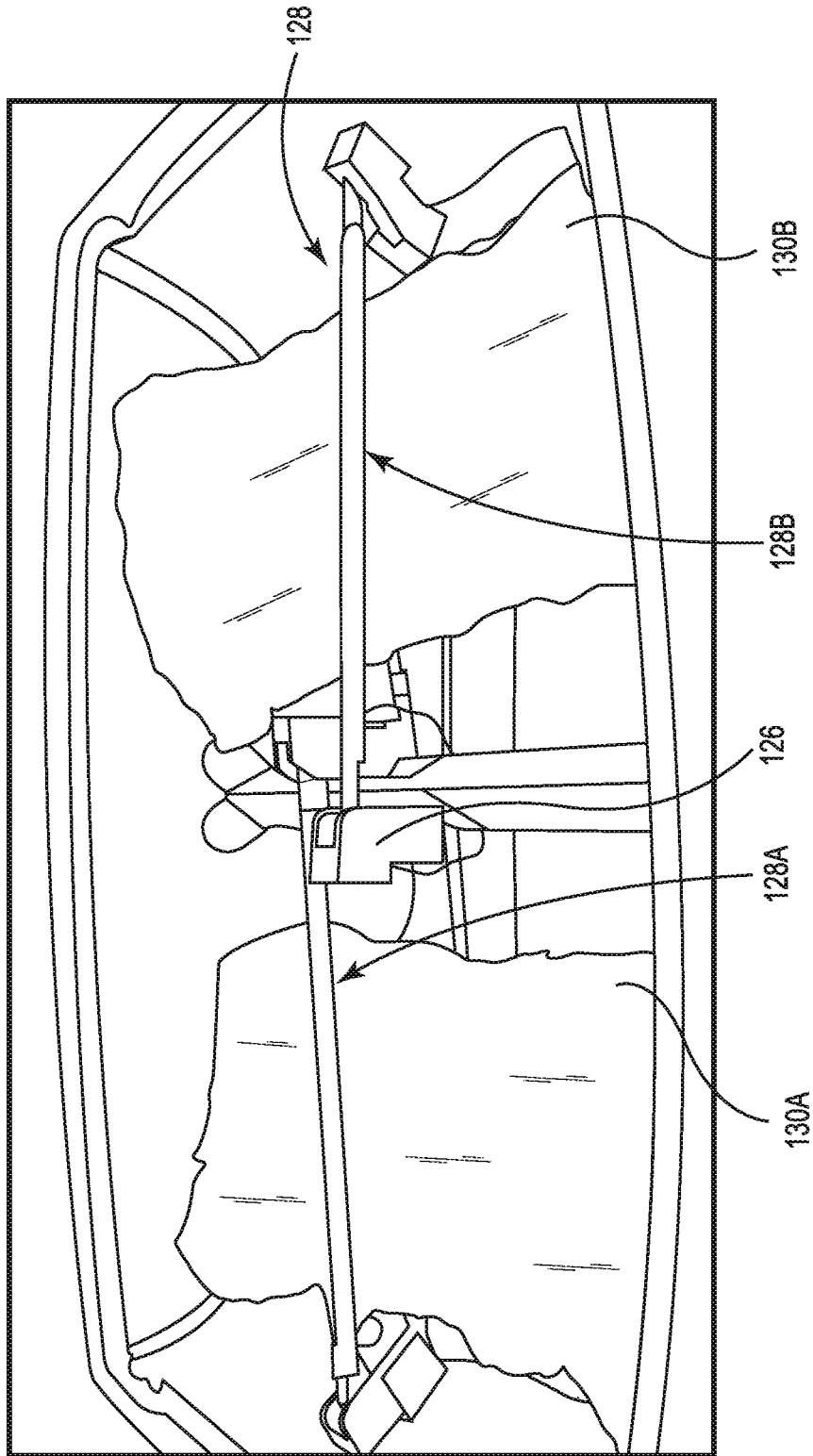

Fig. 2B

**INTERNATIONAL SEARCH REPORT**

International application No  
PCT/US2017/019037

**A. CLASSIFICATION OF SUBJECT MATTER**  
INV. A47J37/07  
ADD.  
  
According to International Patent Classification (IPC) or to both national classification and IPC

**B. FIELDS SEARCHED**  
Minimum documentation searched (classification system followed by classification symbols)  
A47J  
  
Documentation searched other than minimum documentation to the extent that such documents are included in the fields searched

Electronic data base consulted during the international search (name of data base and, where practicable, search terms used)  
EPO-Internal, WPI Data

**C. DOCUMENTS CONSIDERED TO BE RELEVANT**

Category*	Citation of document, with indication, where appropriate, of the relevant passages	Relevant to claim No.
X	US 2011/049125 A1 (HOME WILLIAM [TW]) 3 March 2011 (2011-03-03) paragraphs [0029] - [0035]; figures -----	1,4, 6-10,15
X	WO 2015/044164 A1 (KONINKL PHILIPS NV [NL]) 2 April 2015 (2015-04-02) page 25, line 14 - page 33, line 26; figures -----	1-7,9-15
X	EP 2 807 967 A1 (SPECTRUM BRANDS INC [US]) 3 December 2014 (2014-12-03) paragraphs [0008] - [0024], [0042]; figures -----	1-4,6-15
X	CN 204 207 619 U (CHEN QI) 18 March 2015 (2015-03-18) paragraphs [0028] - [0064]; figures ----- -/--	1,2,4, 6-15

Further documents are listed in the continuation of Box C.  See patent family annex.

\* Special categories of cited documents :

<p>"A" document defining the general state of the art which is not considered to be of particular relevance</p> <p>"E" earlier application or patent but published on or after the international filing date</p> <p>"L" document which may throw doubts on priority claim(s) or which is cited to establish the publication date of another citation or other special reason (as specified)</p> <p>"O" document referring to an oral disclosure, use, exhibition or other means</p> <p>"P" document published prior to the international filing date but later than the priority date claimed</p>	<p>"T" later document published after the international filing date or priority date and not in conflict with the application but cited to understand the principle or theory underlying the invention</p> <p>"X" document of particular relevance; the claimed invention cannot be considered novel or cannot be considered to involve an inventive step when the document is taken alone</p> <p>"Y" document of particular relevance; the claimed invention cannot be considered to involve an inventive step when the document is combined with one or more other such documents, such combination being obvious to a person skilled in the art</p> <p>"&amp;" document member of the same patent family</p>
---	---

Date of the actual completion of the international search  31 May 2017	Date of mailing of the international search report  19/06/2017
--	--

Name and mailing address of the ISA/ European Patent Office, P.B. 5818 Patentlaan 2 NL - 2280 HV Rijswijk Tel. (+31-70) 340-2040, Fax: (+31-70) 340-3016	Authorized officer  De Terlizzi, Marino
--	---

## INTERNATIONAL SEARCH REPORT

International application No  
PCT/US2017/019037

C(Continuation). DOCUMENTS CONSIDERED TO BE RELEVANT		
Category*	Citation of document, with indication, where appropriate, of the relevant passages	Relevant to claim No.
X	WO 99/12392 A1 (QUADLUX INC [US]) 11 March 1999 (1999-03-11) page 11, line 17 - page 31, line 30; figures	1-15
X	----- KR 100 512 533 B1 (QUADLUX INC) 5 September 2005 (2005-09-05) page 5, paragraph 1 - page 10, paragraph 4; figures -----	1-15

# INTERNATIONAL SEARCH REPORT

Information on patent family members

International application No PCT/US2017/019037
---

Patent document cited in search report	Publication date	Patent family member(s)	Publication date
US 2011049125	A1	03-03-2011	NONE
-----			
WO 2015044164	A1	02-04-2015	CN 105578936 A 11-05-2016
			EP 3048939 A1 03-08-2016
			KR 20160058925 A 25-05-2016
			US 2016227964 A1 11-08-2016
			WO 2015044164 A1 02-04-2015
-----			
EP 2807967	A1	03-12-2014	CA 2852976 A1 30-11-2014
			CN 104207658 A 17-12-2014
			EP 2807967 A1 03-12-2014
			US 2014352553 A1 04-12-2014
-----			
CN 204207619	U	18-03-2015	NONE
-----			
WO 9912392	A1	11-03-1999	AU 737538 B2 23-08-2001
			BR 9806163 A 07-11-2000
			CA 2270907 A1 11-03-1999
			EP 0938833 A1 01-09-1999
			JP 3289917 B2 10-06-2002
			JP 2001506360 A 15-05-2001
			WO 9912392 A1 11-03-1999
-----			
KR 100512533	B1	05-09-2005	NONE
-----			