

(19) World Intellectual Property
Organization
International Bureau



(43) International Publication Date
19 May 2005 (19.05.2005)

PCT

(10) International Publication Number
WO 2005/044126 A1

- (51) International Patent Classification⁷: **A61B 19/00**, 38017 (US). **RABURN, Kevin** [US/US]; 1670 Ronda Street, Memphis, TN 38108 (US).
17/34
- (21) International Application Number: PCT/US2003/031594
- (22) International Filing Date: 6 October 2003 (06.10.2003)
- (25) Filing Language: English
- (26) Publication Language: English
- (30) Priority Data:
10/679,158 3 October 2003 (03.10.2003) US
- (71) Applicant (for all designated States except US): **SMITH & NEPHEW, INC.** [US/US]; 1450 Brooks Road, Memphis, TN 38116 (US).
- (72) Inventors; and
- (75) Inventors/Applicants (for US only): **RUSSELL, Thomas, A.** [US/US]; 10328 Crooked Creek Road, Collierville, TN 38017 (US). **TERRILL-GRISONI, Lauralan** [US/US]; 2554 Ashburton Place North, Cordova, TN 38016 (US). **CULLEY, Patrick, J.** [US/US]; 3752 Davies Manor Drive, Memphis, TN 38133 (US). **RUFFIN, Therise** [US/US]; 1402 Crossview Lane, Collierville, TN
- (74) Agent: **PRATT, John, S.**; Kilpatrick Stockton LLP, Suite 2800, 1100 Peachtree Street, Atlanta, GA 30309-4530 (US).
- (81) Designated States (national): AE, AG, AL, AM, AT, AU, AZ, BA, BB, BG, BR, BY, BZ, CA, CH, CN, CO, CR, CU, CZ, DE, DK, DM, DZ, EC, EE, EG, ES, FI, GB, GD, GE, GH, GM, HR, HU, ID, IL, IN, IS, JP, KE, KG, KP, KR, KZ, LC, LK, LR, LS, LT, LU, LV, MA, MD, MG, MK, MN, MW, MX, MZ, NO, NZ, OM, PH, PL, PT, RO, RU, SC, SD, SE, SG, SK, SL, TJ, TM, TN, TR, TT, TZ, UA, UG, US, UZ, VC, VN, YU, ZA, ZM, ZW.
- (84) Designated States (regional): ARIPO patent (GH, GM, KE, LS, MW, MZ, SD, SL, SZ, TZ, UG, ZM, ZW), Eurasian patent (AM, AZ, BY, KG, KZ, MD, RU, TJ, TM), European patent (AT, BE, BG, CH, CY, CZ, DE, DK, EE, ES, FI, FR, GB, GR, HU, IE, IT, LU, MC, NL, PT, RO, SE, SI, SK, TR), OAPI patent (BF, BJ, CF, CG, CI, CM, GA, GN, GQ, GW, ML, MR, NE, SN, TD, TG).
- Published:
— with international search report
- For two-letter codes and other abbreviations, refer to the "Guidance Notes on Codes and Abbreviations" appearing at the beginning of each regular issue of the PCT Gazette.

(54) Title: SURGICAL POSITIONERS

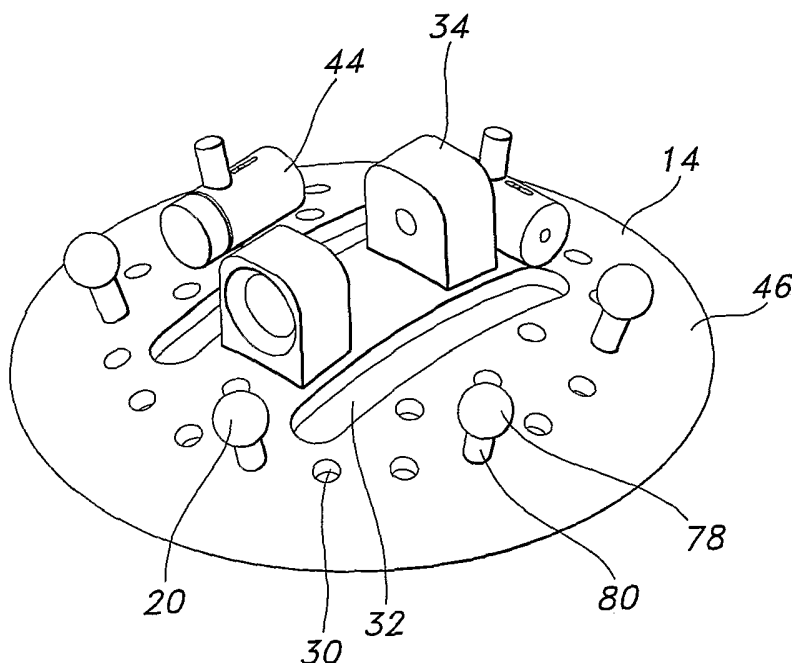

(57) Abstract: Surgical positioners may include platforms, surgical item positioners and/or surgical references as well as methods for using stabilizer platforms, surgical item positioners and/or surgical references. Stabilizer platforms may include low profile platforms rigidly mounted to portions of an individual's anatomy. Various items may be secured and/or stabilized by the stabilizer platform, including support platforms as well as surgical references. Support platforms may stabilize and assist surgeons in using, navigating, aligning and positioning surgical items. Surgical references may include modular fiducial systems that may be secured to stabilizer platforms, support platforms, surgical items and/or directly to portions of an individual's anatomy.

WO 2005/044126 A1

SURGICAL POSITIONERS

CROSS-REFERENCE TO RELATED APPLICATION

This application claims priority to U.S. Serial No.
5 filed with the U.S. Patent and Trademark Office on October 3, 2003,
entitled "Surgical Positioners," the contents of which are incorporated
herein by reference.

BACKGROUND

10 A major concern during surgical procedures as well as other medical
operations is carrying out the procedures with as much precision as is
possible. For example, in orthopedic procedures, less than optimum
alignment of implanted prosthetic components may cause undesired wear,
which may eventually lead to the failure of the implanted prosthesis and
15 necessitate revision. Other general surgical procedures, such as body
exploration from penetrating trauma, implant placement and neoplasm
surgery, also require precision in their execution.

With orthopedic procedures, previous practices have made precise
alignment of prosthetic components challenging. For example, in a total
20 knee arthroplasty, previous instrument design for resection of bone limited
the alignment of the femoral and tibial resections to average values for
varus/valgus, flexion/extension and external/internal rotation. Additionally,
surgeons often use visual landmarks or "rules of thumb" for alignment,
which can be misleading due to anatomical variability. Intramedullary
25 referencing instruments are also undesirable because they violate the
femoral and tibial canals, increasing the risk of fat embolism and
unnecessary blood loss in the patient. Similar problems may also be
encountered in other procedures, such as the replacement of hip and
shoulder joints as well as the insertion of an intramedullary canal nail into a
30 weakened or broken bone.

Several manufacturers currently produce image-guided surgical
navigation systems that are used to assist in performing surgical

procedures with greater precision. The TREON™ and iON™ systems with FLUORONAV™ software manufactured by Medtronic Surgical Navigation Technologies, Inc. are examples of such systems. The BrainLAB VECTORVISION™ system is another example of such a surgical navigation system. Systems and processes for accomplishing image-guided surgery are also disclosed in USSN 10/084,012, filed February 27, 2002 and entitled "Total Knee Arthroplasty Systems and Processes"; USSN 10/084,278, filed February 27, 2002 and entitled "Surgical Navigation Systems and Processes for Unicompartamental Knee Arthroplasty"; USSN 10/084,291, filed February 27, 2002 and entitled "Surgical Navigation Systems and Processes for High Tibial Osteotomy"; International Application No. US02/05955, filed February 27, 2002 and entitled "Total Knee Arthroplasty Systems and Processes"; International Application No. US02/05956, filed February 27, 2002 and entitled "Surgical Navigation Systems and Processes for Unicompartamental Knee Arthroplasty"; International Application No. US02/05783 entitled "Surgical Navigation Systems and Processes for High Tibial Osteotomy"; USSN 10/364,859, filed February 11, 2003 and entitled "Image Guided Fracture Reduction," which claims priority to USSN 60/355,886, filed February 11, 2002 and entitled "Image Guided Fracture Reduction"; and USSN 60/271,818, filed February 27, 2001 and entitled "Image Guided System for Arthroplasty"; USSN 10/229,372, filed August 27, 2002 and entitled "Image Computer Assisted Knee Arthroplasty", the entire contents of each of which are incorporated herein by reference as are all documents incorporated by reference therein.

These systems and processes use position and/or orientation tracking sensors such as infrared sensors acting in a stereoscopic manner or other sensors acting in conjunction with reference structures or reference transmitters to track positions of body parts, surgery-related items such as implements, instruments, trial prosthetics, prosthetic components, and virtual constructs or references such as rotational axes which have been calculated and stored based on designation of bone

landmarks. Processing capability such as any desired form of computer functionality, whether standalone, networked, or otherwise, takes into account the position and orientation information as to various items in the position sensing field (which may correspond generally or specifically to all or portions or more than all of the surgical field) based on sensed position and orientation of their associated reference structures such as fiducials, reference transmitters, or based on stored position and/or orientation information. The processing functionality correlates this position and orientation information for each object with stored information, such as a computerized fluoroscopic imaged file, a wire frame data file for rendering a representation of an instrument component, trial prosthesis or actual prosthesis, or a computer generated file relating to a rotational axis or other virtual construct or reference. The processing functionality then displays position and orientation of these objects on a screen or monitor. Thus, these systems and processes, by sensing the position of reference structures or transmitters, can display or otherwise output useful data relating to predicted or actual position and orientation of body parts, surgically related items, implants, and virtual constructs for use in navigation, assessment, and otherwise performing surgery or other operations.

Some of these reference structures or reference transmitters may emit or reflect infrared light that is then detected by an infrared camera. The references may be sensed actively or passively by infrared, visual, sound, magnetic, electromagnetic, x-ray, or any other desired technique. An active reference emits energy, and a passive reference merely reflects energy. In some embodiments, the reference structures have at least three, but usually four, markers or fiducials that are tracked by an infrared sensor to determine the position and orientation of the reference and thus the position and orientation of the associated instrument, implant component or other object to which the reference is attached.

The Medtronic imaging systems allow reference structures to be detected at the same time the fluoroscopy imaging is occurring. This

allows the position and orientation of the reference structures to be coordinated with the fluoroscope imaging. Then, after processing position and orientation data, the reference structures may be used to track the position and orientation of anatomical features that were recorded with a fluoroscope. Computer-generated images of instruments, components, or other structures that are fitted with reference structures may be superimposed on the fluoroscopic images. The instruments, trial, implant or other structure or geometry can be displayed as 3-D models, outline models, or bone-implant interface surfaces.

10 The reference structures described above are an important component of these systems and processes. FIG. 1 shows a reference structure 8 secured to a bone. FIG. 2 shows reference structures 8 as used in a surgical setting. In some systems, a reference transmitter, as opposed to a passive reference structure, actively transmits position and orientation data to the tracking system. FIG. 3 shows a reference transmitter or receiver 10 secured to a bone that is useable with such systems.

 Systems such as the Medtronic system may monitor the location and orientation of the reference structures 8, and consequently the portion of the anatomy or instruments secured to the reference structure 8, by either actively or passively detecting the position of fiducials 12 shown in FIGS. 1 and 2 associated with the reference structure 8. Because the fiducials 12 can be arranged in particular patterns, the system can determine the exact orientation and location of the reference structure 8 associated with the fiducials 12. In other words, depending upon the particular location of the individual fiducials 12, the system will "see" the reference structure 8 in a particular way and will be able to calculate the location and orientation of the reference structure based upon that data. Consequently, the system can determine the exact orientation and location of the portion of the anatomy or instrument associated with and connected to the reference structure 8.

As discussed above, the exact spatial relationship of the individual fiducials 12 with respect to each other and the associated anatomy or instrument forms the basis of how a fiducial-based system calculates the position and orientation of the associated items. Similarly, the exact spatial relationship of a reference transmitter or receiver 10 with respect to its associated anatomy or instrument forms the basis of how a transmitter-based system calculates the position and orientation of the associated anatomy or instruments. Consequently, once the spatial relationship of the fiducials 12 or reference transmitter or receiver 10 with respect to the associated item to be tracked has been registered in the system, subsequent changes in the position and/or orientation of the fiducials 12 or reference transmitter 10 may cause the system to erroneously calculate the position and orientation of the anatomy or instruments associated with the fiducials 12 or reference transmitter 10. Even minor changes in orientation and/or position of the references may lead to dramatic differences in how the system detects the orientation and/or location of the associated anatomy or instruments. Such changes may require the system to be recalibrated, requiring additional fluoroscopy or other imaging to be obtained, increasing the time and the expense of the procedure. Failure to recalibrate the system may lead to imprecision in the execution of the desired surgical procedure.

The references 8 and 10 shown in FIGS. 1-3 may be undesirable because they may be particularly vulnerable to change of location and/or orientation with respect to their associated instrument or anatomy. This may be especially problematic in busy operating rooms, where several people are working at once. References 8 and 10 may be particularly susceptible to being bumped, dislodged, or otherwise misplaced because they are cumbersome and prone to interfering with the surgical procedure because of their size. The references may also be susceptible to change in location and / or orientation because they are secured at a single location by a column or other structure to the bony anatomy, instruments,

or other structure and are distanced from the anatomy to which they are attached.

Some reference structures do not allow the repositioning or removal of individual fiducials with respect to the reference structure. This may be problematic because there may be times when it is desirable to place the reference structure in a location and orientation that can be effectively visualized and tracked by the system, yet remain out of the way of the surgeon. Moreover, reference structures that do not allow removal of the fiducials from the remainder of the reference structure prevent defective or inoperative fiducials from being replaced without replacing the entire reference structure.

Another major concern with carrying out surgeries and other medical operations with absolute precision is precisely targeting, aligning and/or navigating instruments with or without the assistance of image-guided surgical navigation systems. Problematically, during surgery a surgeon may need to use one hand to stabilize an instrument while using the other hand to target, align and/or navigate the instrument. If the surgeon is the sole means for stabilizing as well as aligning / navigating/targeting the instrument, distractions to the surgeon may result in the instrument becoming misaligned, increasing the chances for surgical error and/or increasing procedural tedium. For instance, if the surgeon looks away from the instrument to view a monitor, the surgeon may inadvertently move his or her hands, causing the instrument to move relative to the anatomy.

Some efforts to alleviate the above difficulties include the use of robotic arms. However, robotic arms may require the navigation of the instrument to be programmed and consequently executed without surgeon input during the robotic portion of the procedure. These robotic arms may be undesirable because they prevent the surgeon from using his or her intuition and experience to target, align and/or navigate the instrument. Additionally, these robotic arms prevent the surgeon from receiving tactile feedback, an important part of some surgical procedures. In addition, robots generally operate much more slowly than a skilled surgeon.

Other, non-robotic, instrument mounting arms have also been used to lock a navigated instrument into position. In addition to the other problems mentioned above, some previous instrument mounting arms may be undesirable because readjustment of the instrument, once locked into place, requires unlocking the arm. Unlocking the arm may increase the tedium of the procedure.

SUMMARY

Various aspects and embodiments of the present invention include surgical positioners capable of increasing surgical precision, as well as methods and procedures for utilizing the surgical positioners. These surgical positioners include certain platforms, which are securable to an individual's anatomy, each other, and/or any other desired structure. These platforms may be modular in nature, allowing various surgical items to be secured and/or stabilized in various orientations and locations. They provide stable bases for locating surgical items, including surgical references useful in conjunction with image-guided surgical navigation systems ("tracking systems"), such as the systems discussed above. These platforms may also be used as stable bases for other surgical instruments, used with or without tracking systems, including drills, reamers, surgical guides or any other desired instrumentation. These platforms may also be used to guide the installation of surgical implants, such as intramedullary nails. Consequently, various embodiments of the present invention allow ease of securing, locating, mounting, stabilizing, navigating, targeting, positioning and/or aligning surgical items relative to an individual's anatomy, thereby improving the precision with which surgical procedures may be performed.

In some embodiments, the stabilizer platform is adapted to contact an individual's skin at least at three points on a surface of the platform; adapted to be biased against the individual's skin by at least two fasteners, each of the fasteners connected to bone of the individual such

that at least one of the fasteners is not parallel to at least one other of the fasteners; and adapted to support at least one item.

In some embodiments, the stabilizer platform is adapted to contact an individual's skin at at least three points. The stabilizer platform may be
5 biased against the individual by a number of fasteners such that at least two of the fasteners are not parallel with respect to one another. Biasing the platform against the individual's skin in this manner may secure the platform to the individual's anatomy in a stable manner. The non-parallel orientation of the fasteners may resist various pushing, pulling, twisting
10 and/or other forces applied intentionally or accidentally to the fasteners, the stabilizer platform or other items secured to the stabilizer platform. In some embodiments, the stabilizer platform can be adapted such that at least some of the fasteners converge towards one another, creating an especially stable relationship between the stabilizer platform and the
15 individual's anatomy.

Other embodiments according to certain aspects of this invention provide methods and procedures for utilizing, securing, stabilizing and aligning various surgical referencing positioners, navigating positioners, and other items with respect to a portion of an individual's anatomy. These
20 methods secure the stabilizer platform to the individual's anatomy such that it is less likely to be dislodged or repositioned due to inadvertent contact.

In some embodiments, the surgical positioners may include a surgical item positioner. The surgical item positioner, which may include a
25 stabilizing system (such as, but not limited to stabilizer platforms coupled with arms) and an support platform adapted to connect to the stabilizing system, may assist a surgeon to precisely navigate, align, position, secure and/or balance a surgical item during surgical procedures. The surgical instrument positioner may include a support platform. The support
30 platform may be similar to or different from the stabilizer platform.

In some embodiments, the surgical item positioner may include a support platform and a stabilizing system. The support platform may be

adapted to contact an individual's skin at least at three points on a surface of the platform and support at least one item; and may be adapted to connect to a stabilizing system. The stabilizing system may be adapted to connect to the support platform, stabilize the support platform, and be
5 biased against the individual by at least one fastener. The stabilizing system, biased against a portion of an individual's anatomy, may stabilize the support platform.

Some embodiments of the present invention include a method of establishing a reference for use as a navigational aid in surgery, the
10 reference being less likely to be accidentally repositioned during surgical procedures. The method may include: positioning and securing a first modular fiducial to a structure; positioning and securing a second modular fiducial to the structure, the second modular fiducial able to be positioned at least somewhat independently of the first modular fiducial; and
15 positioning and securing at least one additional modular fiducial to the structure, the at least one additional modular fiducial able to be positioned at least somewhat independently of the first modular fiducial and the second modular fiducial. The first, second and at least one additional modular fiducials may be positioned in one of a plurality of patterns, some
20 of the patterns recognizable by a tracking system such that the tracking system can track the position and orientation of the pattern.

Establishing a reference using modular fiducials may provide a surgical reference that is less likely to be repositioned due to undesired or unintended contact. References formed from modular fiducials may also
25 allow placing the fiducials in locations that maximize visibility to the tracking system while remaining out of the surgeon's way.

In some embodiments, the referenced item may be a surgical item, such as a platform, drill, drill-guide, working channel, trial implant or any other desired item. In embodiments where a platform is the referenced
30 item, tracking the platform may also allow tracking of the anatomical structure to which the platform is secured. In other embodiments, the

modular fiducials may be individually and directly attached to the anatomical structure.

Other aspects and embodiments of the present invention will become apparent by reference to the remainder of this document.

5

STATEMENT OF INVENTION

In accordance with aspects of the present invention, there is provided:

A surgical positioner for supporting items used in surgery, the
10 surgical positioner comprising a platform characterized in that the platform includes structure which is adapted to: (i) contact an individual's skin at least at three points on a surface of the platform; (ii) be biased against the individual's skin by at least two fasteners, each of the fasteners connected to bone of the individual such that at least one of the fasteners is not
15 parallel to at least one other of the fasteners; and (iii) support at least one item by capturing a portion of the item.

A surgical positioner further characterized in that the platform includes a plurality of apertures defined by portions of the platform, at least one of the apertures adapted to receive one of the fasteners.

20 A surgical positioner further characterized in that the platform includes a first platform surface and a second platform surface, at least some of the plurality of apertures extending from the first platform surface to the second platform surface, the first platform surface defining a convex surface and the second platform surface defining a concave surface.

25 A surgical positioner further characterized in that at least two of the apertures are each adapted to receive one of the fasteners such that the at least two fasteners received by the apertures converge towards each other.

A surgical positioner further characterized in that the at least one
30 item includes at least one fiducial.

A surgical positioner further characterized in that the at least one fiducial includes at least one modular fiducial.

A surgical positioner further characterized in that at least three of the plurality of apertures defined by portions of the platform are adapted to receive at least three modular fiducials such that the modular fiducials can be received by at least some of the apertures such that the modular
5 fiducials form a pattern, the pattern recognizable by a tracking system such that the tracking system can track the position and orientation of the pattern.

A surgical positioner further characterized in that the at least one item includes a drill guide.

10 A surgical item positioner for supporting an item used in surgery characterized in that the surgical positioner includes:

(a) a support platform adapted to: (i) contact an individual's skin at least at three points on a surface of the platform; (ii) support at least one item; and (iii) be connected to a stabilizing system; and

15 (b) the stabilizing system, the stabilizing system adapted to: (i) connect to the support platform; (ii) stabilize the support platform; and (iii) be biased against the individual by at least one fastener.

A surgical item positioner further characterized in that the stabilizing system comprises:

20 (a) a stabilizer platform, the stabilizer platform adapted to: (i) contact an individual's skin at least at three points on a surface of the stabilizer platform; (ii) be biased against the individual's skin by at least two fasteners such that at least one of the fasteners is not parallel to at least one other of the fasteners; and (iii) be connected to the support platform by
25 an arm; and

(b) the arm, the arm adapted to connect the support platform to the stabilizer platform.

A surgical item positioner further characterized in that the stabilizer platform is adapted to receive the at least two fasteners such that the at
30 least two fasteners converge towards each other, the at least two fasteners adapted to be secured to the bony anatomy of the individual.

A surgical item positioner further characterized in that the arm comprises a flexible arm.

5 A surgical item positioner further characterized in that portions of the support platform define a portal, the portal adapted to receive the at least one item.

A surgical item positioner further characterized in that the portal is adapted to interact with a bearing in a rotating fashion, the bearing adapted to interact with portions of the item in a rotating and sliding fashion.

10 A surgical item positioner further characterized in that the bearing further comprises a plurality of protrusions extending from an outer surface of the bearing, at least some of the protrusions adapted to interact with a channel at least partially extending around an interior circumference of the portal.

15 A reference for use as a navigational positioner in surgery characterized in that the reference includes:

(a) a first modular fiducial secured to a structure;
(b) a second modular fiducial secured to the structure, the second modular fiducial positioned at least somewhat independently of the first modular fiducial; and

20 (c) at least one additional modular fiducial secured to the structure, the at least one additional modular fiducial positioned at least somewhat independently of the first modular fiducial and the second modular fiducial, wherein the first, second and at least one additional modular fiducials are positioned in one of a plurality of patterns, some of the patterns recognizable by a tracking system such that the tracking system can track the position and orientation of the pattern.

25 A reference further characterized in that portions of the first, second and at least one additional modular fiducials are captured and supported by a platform adapted to: (i) contact an individual's skin at least at three points on a surface of the platform; and (ii) be biased against the individual's skin by at least two fasteners, each of the fasteners connected

to bone of the individual such that at least one of the fasteners is not parallel to at least one other of the fasteners.

A reference further characterized in that the first, second and at least one additional modular fiducials are captured and supported by a plurality of apertures defined by the platform.

A reference further characterized in that the first, second and at least one additional modular fiducials are secured to a portion of an individual's bony anatomy.

A method for establishing a reference for use as a navigational positioner in surgery characterized in that the method includes: positioning and securing a first modular fiducial to a structure; positioning and securing a second modular fiducial to the structure, the second modular fiducial able to be positioned at least somewhat independently of the first modular fiducial; and positioning and securing at least one additional modular fiducial to the structure, the at least one additional modular fiducial able to be positioned at least somewhat independently of the first modular fiducial and the second modular fiducial, wherein the first, second and at least one additional modular fiducials are positioned in one of a plurality of patterns, some of the patterns recognizable by a tracking system such that the tracking system can track the position and orientation of the pattern.

A method for establishing a reference for use as a navigational positioner in surgery, further characterized in that securing the first, second and at least one additional modular fiducials includes securing the first, second and at least one additional modular fiducials to a platform and biasing the platform against an individual's skin.

A method for establishing a reference for use as a navigational positioner in surgery, further characterized in that biasing the platform against the individual's skin includes biasing the platform against the individual's skin using at least two fasteners, the platform adapted to be biased against the individual's skin by the at least two fasteners such that the at least two fasteners converge towards each other.

A method for establishing a reference for use as a navigational positioner in surgery, further characterized in that securing the first, second and at least one additional modular fiducials includes inserting ends of the modular fiducials into apertures defined by portions of the platform.

5 A method for establishing a reference for use as a navigational positioner in surgery, further characterized in that securing the first, second and at least one additional modular fiducials includes inserting the modular fiducials into apertures associated with identifiers.

10 A method for establishing a reference for use as a navigational positioner in surgery, further characterized in that securing the first, second and at least one additional modular fiducial includes securing the first, second and at least one additional modular fiducial to a portion of an individual's bony anatomy.

15 A method for establishing a reference for use as a navigational positioner in surgery, further characterized in that the tracking system provides feedback if the pattern created by the first, second and at least one additional modular fiducials is not recognizable by the tracking system.

20 A method for establishing a reference for use as a navigational positioner in surgery, further characterized in that the method includes using the tracking system to position an implant relative to an individual and installing the implant.

BRIEF DESCRIPTION OF THE DRAWINGS

25 FIG. 1 shows a side view of a reference structure secured to a portion of bone.

FIG. 2 shows a side view of two reference structures secured to portions of an individual's leg.

FIG. 3 shows a side view of a reference transmitter secured to a portion of bone.

30 FIG. 4 shows a perspective view of a stabilizer platform according to a first embodiment of the present invention biased against an individual's skin.

FIG. 5 shows a perspective view of a number of platforms according to another embodiment of the present invention, some of the platforms biased against an individual's skin and some of the platforms connected to some of the other platforms.

5 FIG. 6 shows a perspective view of a number of platforms according to another embodiment of the present invention, some of the platforms being used to guide and stabilize a surgical drill.

FIG. 7 shows a side sectional schematic view of a stabilizer platform according to another embodiment of the present invention.

10 FIG. 8 shows a perspective view of a stabilizer platform according to another embodiment of the present invention.

FIG. 9 shows a perspective view of a support platform according to another embodiment of the present invention.

15 FIG. 10 shows a perspective view of a support platform according to another embodiment of the present invention.

FIG. 11 shows a perspective view of a support platform according to another embodiment of the present invention.

FIG. 12 shows a perspective view of a rigid arm useful in certain embodiments of the present invention.

20 FIG. 13 shows a perspective view of a flexible arm useful in certain embodiments of the present invention.

FIG. 14 shows a perspective view of a bearing useful in certain embodiments of the present invention.

25 FIG. 15 shows a perspective view of a surgical instrument positioner according to another embodiment of the present invention.

FIG. 16 shows a perspective view of a modular fiducial according to another embodiment of the present invention.

30 FIG. 17 shows a perspective view of a stabilizer platform including a number of the modular fiducials of FIG. 16 according to another embodiment of the present invention.

FIG. 18 shows a schematic side view of the modular fiducial of FIG. 16.

FIG. 19 shows a schematic side view of a modular fiducial according to another embodiment of the present invention.

FIG. 20 shows a schematic side view of a modular fiducial according to another embodiment of the present invention.

5 FIG. 21 shows a schematic view of a tracking system according to another embodiment of the present invention.

DETAILED DESCRIPTION

FIG. 4 shows a platform 14 according to various aspects and
10 embodiments of the present invention. The platform 14 may be used as a stabilizer platform by being biased against portions of an individual's anatomy to provide a stable and low profile platform for securing other items that may be useful in various surgical procedures. Items may be secured to or stabilized by stabilizer platform 14 in a releasable, rigid
15 and/or movable manner.

Stabilizer platform 14 may be formed from any desired and suitable material and in any desired and suitable method. For instance, in some embodiments, stabilizer platform 14 may be formed from high impact, vacuum molded plastic. In other embodiments, stabilizer platform 14 may
20 be machined from stainless steel or aluminum.

Any desired item may be supported by stabilizer platform 14. Various items that may be supported by stabilizer platform 14 include, but are not limited to, reference transmitters (such as the reference transmitter 18 shown in FIG. 4), reference receivers, fiducials (such as the modular
25 fiducials 20 shown in FIGS. 16-20), flexible arms (such as the flexible arm 22 shown in FIG. 13), rigid arms (such as the rigid arm 24 shown in FIG. 12), rotating arms, drill guides (such as the drill guide 60 shown in FIG. 15), drills (such as the drill 86 shown in FIG. 6), saws, reamers, other orthopedic instruments, other stabilizer platforms 14, support platforms
30 (such as the support platforms 26 a, b and c shown in FIGS. 9-11), monitoring devices, prosthetics or any other desired instrument or other item or structure. Instrument receivers such as apertures 30, slots 32,

protrusions 34, instrument portals 50 a, b, and c, or other suitable structures for capturing, securing and/or stabilizing items may be included at various locations on stabilizer platform 14. Consequently, items may be supported in various locations and orientations as is desired and/or
5 convenient.

Reference transmitters 18, may be formed similarly and function similarly to typical reference transmitters 10 for use in tracking systems, such as the tracking systems described in the documents incorporated by reference into this document. However, reference transmitters 18, when
10 captured and stabilized by a stabilizer platform 14, which is in turn secured to an individual's anatomy, may be more secure, stable and/or may be less likely to be dislodged and/or repositioned than typical reference transmitters 10 secured to an individual's anatomy in typical fashions. FIG. 4 shows a reference transmitter 18 captured by protrusions 34, securing
15 the reference transmitter 18 to the platform 14.

Items may be captured by receivers, securing the items to the platform 14. Receivers may be apertures 30 extending through portions of stabilizer platform 14. Some of the other receivers shown in FIG. 4 are protrusions 34 extending through stabilizer platform 14 and slots 32
20 extending through portions of stabilizer platform 14. In other embodiments, receivers may be any desired structure capable of capturing or securing instruments or any other desired item. For instance, receivers may include locks, channels, clamps, receptors or any structure adapted to support instruments or any other desired item.

25 Stabilizer platform 14 may be biased against a portion of an individual's anatomy, such as the skin, by fasteners. Fasteners may be any suitable structure adapted to secure stabilizer platform 14 to a portion of an individual's anatomy, such as, but are not limited to, surgical pins, fixation pins 38, surgical screws, other screws, bolts, straps, bands,
30 adjustable collars or clamps. In certain embodiments, such as the embodiment shown in FIG. 4, a number of fixation pins 38 are used as fasteners.

Fixation pins 38 may secure stabilizer platform 14 to any desired and/or suitable portion of an individual's anatomy, such as body tissue, soft tissue, muscles, tendons, ligaments, cartilage, bony anatomy or any other desired and/or suitable anatomy. In certain embodiments of the present invention, fixation pins are inserted into bony anatomy to rigidly secure stabilizer platform 14. For instance, in embodiments where modular fiducials 20 or reference transmitters 18 for use with tracking systems are to be secured to stabilizer platform 14, the stabilizer platform 14 may be rigidly secured to a portion of an individual's bony anatomy to reduce the chance that the attached reference structure or structures will move.

Fixation pins 38, as well as other appropriate fasteners, may be assisted by retainers of various kinds. Retainers may assist fasteners to bias stabilizer platform 14 against an individual's skin. Retainers may include, but are not limited to, wing nuts 42 (as shown in FIG. 4), nuts, connectors 44 (as shown in FIG. 8), spring-loaded connectors, threaded connectors, spring-loaded threaded connectors, clips, e-clips, d-clips, snap locks or any other suitable structure. In certain embodiments, wing nuts 42, connectors 44 or both are used to assist fixation pins 38 to rigidly secure the stabilizer platform 14.

However, retainers are not required. Friction and/or other forces present between fixation pins 38 and apertures 30 may be sufficient to secure stabilizer platform 14 to a desired item in a stable fashion.

FIG. 7 shows stabilizer platform 14 including a first platform surface 46 and a second platform surface 48. First and second platform surfaces 46 and 48 may be formed in any desired and suitable shape and located in any desired and suitable orientation. The stabilizer platform shown in FIGS. 7 and 8 is generally circular, first platform surface 46 is an upper convex surface and second platform surface 48 is a lower concave surface. However, stabilizer platform 14 may be any shape appropriate to the anatomy to be treated, such as rectangles, triangles, ovals, squares, three-dimensional shapes, or any other desired shape. The size and shape of stabilizer platform 14 as well as the curvature and orientation of

first upper convex platform surface 46 and second lower concave surface 48 may be adapted such that stabilizer platform 14 may be placed flush against a desired portion of an individual's anatomy, such as the individual's skin, with a low profile. This reduces the chance that stabilizer platform 14, or items secured to it, will experience unintentional contact during surgical procedures. The low profile of the stabilizer platform 14 also stabilizes the platform.

In some embodiments, second platform surface 48 is adapted to contact an individual's skin at least at three points. In the embodiment shown in FIG. 4 the lower surface 48 of platform 14 is adapted to contact an individual's skin at numerous points, lending stability to the platforms 14. In a preferred embodiment, platform 14 is formed from a semi-rigid material, allowing a large number of points of the platform to contact an individual's skin and conforming the platform to the individual's skin to create an especially stable platform.

In other embodiments, stabilizer platform 14 may be mounted to a table. In these embodiments, stabilizer platform 14 may preferably support at least three modular fiducials.

As shown in FIG. 7, apertures 30 extend from first surface 46 to second surface 48. Apertures 30 may be formed in any desired and/or suitable size or shape. For example, apertures 30 are shown as circular and adapted to receive commercially available fixation pins. In a particular embodiment, apertures 30 are approximately 6 millimeters in diameter such that the apertures 30 may accept fixation pins 38 having diameters of approximately 5 millimeters. In some embodiments where apertures 30 are larger than fixation pins 38, surgeons may be able to adjust the position and/or orientation of the fixation pin 38 with respect to features of the individual's anatomy. In other embodiments, apertures 30 are circular and are approximately 5 millimeters in diameter such that the apertures 30 may accept fixation pins 38 having diameters of approximately 5 millimeters for a tight, secure fit. Additionally, any desired and/or suitably sized fixation pin 38, or other fastener may be used. Also, any desired

and/or suitable number of fasteners may be used. Generally, increasing the number of fasteners may increase the stability of platform 14.

Apertures 30 may be formed such that the axes of at least some of the apertures 30 are not parallel with respect to at least some of the other apertures 30. As shown in FIG. 7, in some embodiments, some or all of the apertures 30 may be formed such that lower ends of the apertures 92 converge towards each other with respect to the upper ends 94 of the apertures 30. In other embodiments, apertures 30 may have lower ends 92 of the apertures 30 that diverge from each other with respect to the upper ends 94 of the apertures 30. For instance, the apertures 30 can be oriented so that their axes are radii of the curve forming platform 14. In still other embodiments, apertures 30 may be formed in other orientations with respect to one another.

In embodiments where apertures 30 converge towards each other, fixation pins 38 may also converge towards one another when inserted through apertures 30. The convergence of fixation pins 38 may rigidly secure stabilizer platform 14 to a portion of an individual's anatomy, such as the bony anatomy, rigidly biasing the stabilizer platform 14 against the individual's skin. In other embodiments, similar stabilizing effects may be achieved with aperture 30 and fastener arrangements allowing at least some fasteners to be non-parallel with respect to one another.

Preferably, apertures 30 are of sufficient diameter to permit fixation pins 38, or any other desired fasteners, to be inserted through stabilizer platform 14 such that at least one of the fixation pins 38 is not parallel with respect to at least one other fixation pin 38. In some embodiments, apertures 30 are of sufficiently large diameter (or optionally fixation pins 38 are of sufficiently small diameter) to permit fixation pins 38 to converge at distal ends 96 relative to proximate ends 98 of fixation pins 38. Securing stabilizer platforms 14 in the manners described above may allow a surgeon to control the height of the stabilizer platform 14 relative to desired portions of the individual's anatomy.

In some embodiments, apertures 30 may be formed from structures extending from peripheral portions of stabilizer platform 14, rather than extending from first platform surface 46 to second platform surface 48.

Alternatively, stabilizer platform 14 may be formed without apertures 5 30. In this case, fasteners, such as surgical screws or other appropriate and/or desired fasteners are inserted through portions of stabilizer platform 14 into portions of an individual's anatomy or fasteners may be integral to stabilizer platform 14 and may extend downward from second platform surface 48. Integral fasteners may include prongs, barbs or other suitable 10 structures. Stabilizer platform 14 with integral fasteners may be biased against an individual's anatomy by pressing or forcing stabilizer platform 14 onto a desired portion of an individual's anatomy. In some embodiments, integral fasteners are formed such that at least one of the integral fasteners is not parallel to at least one other integral fastener. For 15 example, at least one of the integral fasteners may converge towards at least one other integral fastener.

In use, the stabilizer platform 14 may be placed proximate to a portion of the individual's anatomy such that at least three points of the second platform surface 48 contact the skin of the individual. A first 20 fixation pin 38 is inserted through an aperture 30 extending through portions of stabilizer platform 14. Fixation pin 38 may be self-tapping and/or may require the surgeon to first incise and/or drill a pilot hole prior to insertion of fixation pin 38 into the desired portion of the individual's anatomy. Fixation pins 38 may be connected to bone in conventional 25 manners. Next, at least one additional fixation pin 38 is inserted through stabilizer platform 14 into the desired portion of the individual's anatomy. In certain embodiments, fixation pins 38 converge towards one another at distal ends 96, such as is illustrated in FIG. 7. Additional fixation pins 38 may be inserted if desired to provide additional stability and/or rigidity. In 30 embodiments where maximum stability and/or rigidity are desired, fixation pins 38 may be secured to bony anatomy, or other suitable structure. Retainers such as connectors 44 or wing nuts 42 may be secured to

proximal ends of fixation pins 38. Finally, any desired item or items may be secured to the stabilizer platform 14. After the completion of the desired surgical procedures, stabilizer platform 14 may be removed from the individual's anatomy.

5 FIGS. 9-11 show various support platforms 26 a, b and c according to embodiments of the present invention. FIG. 9 shows a first embodiment of a support platform 26a, which may be shaped and sized similarly to stabilizer platform 14 and formed in a similar manner. However, the support platforms of this invention may be formed in any desired shape
10 and size from any desired and/or appropriate material. Support platform 26a includes an instrument portal 50a adapted to receive an item. In some embodiments, support platform 26a may be secured to an individual in a similar or different manner as stabilizer platform 14.

 Items may be supported in a rigid or moveable manner by various
15 embodiments of support platforms 26a, 26b and/or 26c. Exemplary items include, but are not limited to: reference transmitters (such as the reference transmitter 18 shown in FIG. 3), reference receivers, modular fiducials (such as the modular fiducials 20 shown in FIGS. 16-20), active modular fiducials, passive modular fiducials, typical fiducials, typical
20 reference structures, flexible arms (such as the flexible arm 22 shown in FIG. 13), rigid arms (such as the rigid arm 24 shown in FIG. 12), rotatable arms, fasteners, drill guides (such as the drill guide 60 shown in FIG. 15), drills (such as the drill 86 shown in FIG. 6), saws, reamers, other orthopedic instruments, other stabilizer platforms (such as the stabilizer
25 platform 14 shown in FIG. 7), support platforms (such as the support platforms 26a, 26b and 26c shown in FIGS. 9-11), monitoring devices, prosthetics or any other desired instrument or other item. Items may be captured by support platforms 26a, 26b and 26c in ways similar to or the same as items are supported by stabilizer platform 14, for example, by
30 receivers.

 As shown in FIG. 9, receivers include a number of apertures 30 extending through portions of support platform 26a as well as an

instrument portal 50a. Instrument portals may be sized and shaped as desired. For instance, FIGS. 9-11 show instrument portals 50a, 50b and 50c respectively. Item receivers may also be any other structures capable of securing an item, such as the structures on stabilizer platforms 14
5 discussed above.

FIG. 15 shows a support platform 26c attached to a stabilizing system 100, including a stabilizer platform 14 and a rigid arm 24, rather than being directly secured to an individual's anatomy. In this and other embodiments, support platforms 26a, 26b and/or 26c are not secured
10 directly to a portion of an individual's anatomy, but instead, they are at least partially stabilized by an arm, such as the arms 22 and 24 shown in FIGS. 13 and 12 respectively. The arm 22 or 24 can be connected to a stabilizer platform 14, which is in turn rigidly or non-rigidly biased against a portion of an individual's anatomy. The arm 22 or 24 that stabilizes the
15 support platform 26a, 26b or 26c may be secured to the support platform by any appropriate stabilizer receiver, such as apertures 30 or any other appropriate structure.

As shown in FIG. 15, stabilizer platform 14, in connection with an arm 22 or 24, or by itself, may serve as a stabilizing system 100 for a
20 support platform 26c. Stabilizer system 100 may also be used in conjunction with support platforms 26a and 26b. Items associated with support platform 26a, 26b and/or 26c will be stabilized when support platform is connected to stabilizer platform 14 secured to a portion of an individual's anatomy. Use of such a stabilization system may aid a
25 surgeon to precisely navigate, align and/ or position items during orthopedic procedures or other general surgical procedures. A surgeon may connect as many support platforms to stabilizer platform 14 as is desired, obviating the need to use excessive amounts of fasteners in some procedures.

30 FIGS. 12 and 13 show arms 24 and 22 respectively, for stabilizing and/or securing support platforms 26a, 26b and/or 26c with respect to stabilizer platform 14. Arms 22 and 24 may connect to stabilizer platform

14 and/or support platform 26a, 26b and/or 26c by optional snap pins 54 extending from portions of the arms 22 and/or 24. Optional snap pins 54 may be adapted to be inserted into stabilizer receivers such as apertures 30 on stabilizer platform 14 and/or support platforms 26a, 26b and 26c, 5 securing the arm 22 or 24 to either the stabilizer platform 14 or the support platform. Any suitable mechanism may be used to secure arm 22 and/or 24 to the platforms according to various embodiments of the present invention. Alternatively, arm 22 and/or 24 may be integral with one or both of the platforms. As shown in FIGS. 5 and 6, arms 22 may be useful 10 during surgical procedures for stabilizing platforms 26a while still allowing the platform 26a to be moved out of the way when not needed in order to allow the surgeon better visualization.

As shown in FIG. 12, rigid arm 24 may be extendable and retractable. However, rigid arm 24 does not have to be extendable or 15 retractable. In some embodiments, rigid arm 24 may be adapted to rotate relative to stabilizer platform 14 and/or support platforms 26a, 26b and 26c. Use of rigid arm 24 may allow the surgeon to define an arc of a certain radius, useful in some surgical procedures.

FIG. 13 shows a flexible arm 22. Flexible arm 22 may be formed 20 from a plurality of flexible bands 56 secured to one another by a collar 58. In some embodiments, one or more of the flexible bands 56 is formed from a material that is rigidly deformable and features sufficient memory to retain its shape once bent, under normal surgical use. These, or other, characteristics of flexible arm 22 may allow support platforms 26a, 26b or 25 26c to be positioned in a desired location relative to stabilizer platform 14, such as is shown in FIG. 5.

FIG. 15 shows a stabilizer platform 14 connected to a support platform 26c by a rigid arm 24. The support platform 26c is shown as stabilizing a drill guide 60. Drill guide 60 may be inserted through 30 instrument portal 50c (shown in FIG. 11). In other embodiments, a working channel may be inserted through instrument portal 50c (or instrument portals 50a or 50b).

FIG. 15 shows drill guide 60 being supported and/or guided by bearing 62. Bearing 62 may be adapted to interact with the instrument portal at an outer surface 64 (shown in FIG. 14) in a sliding and/or rotating fashion. Bearing 62 may be adapted to capture or interact with instruments such as drill guide 60, at an inner surface 66 in a sliding and/or rotating fashion. Bearing 62 may similarly interact with instrument portal 50c (or instrument portals 50a or 50b) as well as instruments to allow the instruments to be repositioned with respect to support platform 26, yet still be stabilized by support platform 26a, 26b, or 26c. In other embodiments, bearing 62 may be adapted to guide the insertion of a surgical implant, such as a surgical nail.

In the embodiment shown in FIG. 14, bearing 62 includes a number of protrusions 68 extending from portions of the bearing outer surface 64. Protrusions 68 may be formed into any desired and/or suitable shape and dimension. Protrusions 68 may be adapted to interact with portions of portal 50 a, b or c and/or upper and lower surfaces of a support platform such that bearing 62 remains in a desired orientation with respect to the support platform unless reoriented by a surgeon or other user. This feature assists surgeons or other users to properly align items during surgical and other procedures. In certain embodiments, at least one or more of the protrusions 68 may interact with a channel 70 at least partially circumscribing the interior of the instrument portal 50a (as shown in FIG. 9) to assist bearing 62 remaining in desired orientations. Bearing 62 may also be used with instrument portals 50b and 50c in support platforms 26b and 26c respectively.

Another embodiment of a support platform is shown in FIG. 11 as support platform 26c including a sliding ring 72. Sliding ring 72 may be formed from similar materials and in a similar manner as support platform 26c. Sliding ring 72 may be adapted to mount onto a surface on support platform 26c in a flush manner. As shown in FIG. 11, sliding ring 72 includes an upper convex surface 74 and a lower concave surface (not shown). The lower concave surface of sliding ring 72 is adapted to mount

onto the first surface of the support platform 52c. Sliding ring 72 may include apertures 30 formed and shaped in a similar manner to apertures 30 of the support platforms 26a, 26b and 26c and stabilizer platforms 14. Sliding ring 72 may rotate with respect to support platform 26c to allow for fine-tuning of the positioning of items secured to apertures 30 of sliding ring 72.

As shown in FIG. 11, support platform 26c may define a gap 76. The gap 76 in the support platform 26c may extend from instrument portal 50c to an edge of support platform 26c. The gap 76 is adapted to allow the support platform 26c to be removed from items, such as a drill guide 60, during a surgical procedure without requiring removal of the items from the individual's anatomy. A gap may also be formed in sliding ring 72.

In use, stabilizer platform 14 is secured to a portion of an individual's anatomy as described above, proximate an area where the surgeon desires to use an item stabilized and/or guided by support platform 26a, 26b or 26c. One end of flexible arm 22 may be secured to support platform 26a, 26b or 26c by inserting snap pins 54 into apertures 30, and the other end of flexible arm 22 may be secured to stabilizer platform 14 in a similar manner. Support platform 26a, 26b or 26c is then positioned over the desired portion of the individual's anatomy. The desired items may then be inserted through instrument portal 50a, 50b or 50c, or otherwise supported by support platform 26, to allow items such as a drill guide 60 including a bearing 62 with protrusions 68, to be stabilized and/or guided during instrument navigation.

Various aspects and embodiments of the present invention include fiducial structures, such as the modular fiducials 20 shown in FIGS. 16-20. Modular fiducials 20 may be arranged securely on an item to form a pattern, the pattern (and consequently the item the pattern is secured to) capable of being tracked by a tracking system, such as the systems described above. Modular fiducials 20, unlike other reference structures that include three fixed fiducials, may be positioned independently of each other. As shown in FIGS. 16-20, modular fiducials 20 may include

reflective elements 78 which may be tracked by a number of sensors whose output may be processed in concert by associated processing functionality to geometrically calculate the position and orientation of the item to which the modular fiducial 20 is attached. The modular fiducials 20 and the sensors need not be confined to the infrared spectrum. Any electromagnetic, electrostatic, light, sound, radio frequency or other desired technique may be used. Alternatively, modular fiducials 20 may "actively" transmit reference information to a tracking system, as opposed to "passively" reflecting infrared or other forms of energy.

In certain embodiments, the pattern formed by the modular fiducials 20 is one that the tracking system is capable of accurately tracking as the item changes in location and/or orientation. Modular fiducials 20 may be arranged in any pattern as long as the tracking system is able to discern the precise location of the item by tracking the fiducials. FIG. 17 shows an exemplary pattern formed by modular fiducials 20 inserted into apertures 30 on stabilizer platform 14. The pattern formed by modular fiducials 20 allows the tracking system to recognize the position and orientation of the pattern in three dimensions. In other words, as the platform changes position and/or orientation, the tracking system "sees" the pattern and can accurately track the items location and orientation precisely. In some embodiments, modular fiducials 20 that are asymmetrically arranged with respect to one another will form suitable patterns.

Various techniques and methods may be followed to arrange modular fiducials 20 into suitable patterns. Because many patterns will result in suitable and/or acceptable patterns, surgeons may choose to locate modular fiducials 20 in convenient locations and then confirm that the tracking system is properly tracking the changes in position and orientation. Additionally, in some embodiments the tracking system may include a confirmation program that provides feedback to the surgeon, confirming that the modular fiducials 20 form an acceptable pattern and/or recommending alternative patterns that do form acceptable patterns if the surgeon's chosen pattern is inappropriate. In other embodiments

templates may be used, including holes or other indications defining acceptable patterns. In some embodiments where modular fiducials 20 are to be used with the various platforms described in this application and/or surgical instruments, apertures 30 or other structures may be pre-
5 marked, color-coded, indexed or otherwise identified indicating acceptable modular fiducial 20 placement.

In some embodiments, the pattern formed by modular fiducials 20 may be correlated with the orientation and position of the referenced item that the modular fiducials 20 are secured to by obtaining fluoroscopy
10 images of the individual's anatomy at the same time the tracking system is tracking the pattern. In other embodiments, a probe bearing a suitable reference structure, the location and orientation of that reference structure already registered with the tracking system, may be used to register the location and orientation of the pattern and corresponding referenced item.

15 Modular fiducials 20 may be placed in locations to optimize the visibility of the modular fiducials 20 by the sensors of the tracking system. For instance, modular fiducials 20 may be located such that instruments, stabilizer platforms, support platforms, arms, wires, tubes, hoses, monitoring equipment, other equipment, portions of individuals (including
20 the patient) or any other item do not obstruct the sensors "view" of the modular fiducials 20. Modular fiducials 20 may also be located in areas where they will be less likely to be accidentally contacted, repositioned or dislodged.

As shown in FIG. 17, modular fiducials 20 may be low profile in
25 design, reducing the likelihood that they will be accidentally contacted, repositioned or dislodged. FIG. 16 shows a modular fiducial 20 that includes a reflective element 78, a stem 80, and a fastener 82. Fastener 82 is shown having a number of resilient arms 84 that permit modular fiducial 20 to be secured into apertures 30 of the various platforms
30 described in this application, apertures located on an instrument or other item or into any other suitable and/or desired item. Resilient arms 84 may also permit modular fiducial 20 to be easily removed from one location and

repositioned in another location if desired and/or needed. Fasteners 82 may also be formed as threads 88 (as shown in FIG. 19), bayonet pins 90 (as shown in FIG. 20), ball detents or any other suitable structure for securing modular fiducial 20 into apertures 30 or other locations.

5 In alternative embodiments, fastener 82 may be adapted to secure the modular fiducial 20 directly to a portion of an individual's anatomy or instruments to be referenced. For instance, fastener 82 may be a pin, a fixation pin, a screw, a nail, a brad, a staple, a strap or any other suitable structure for securely fixing modular fiducial 20. By way of example,
10 modular fiducials 20 may be rigidly secured to the femur and the tibia, in effect turning each the femur and tibia into reference structures. In some embodiments, securing the modular fiducials 20 directly to the item to be referenced in this manner may improve the accuracy of the tracking system because modular fiducials 20, in comparison to the typical
15 reference structures 8 shown in FIGS. 1 and 2, may be spaced apart further. Consequently, small changes in orientation and/or positioning of the item to be referenced will have a greater effect in how the pattern "looks" with the modular fiducials 20 as opposed to typical reference structures 8. In other words, because modular fiducials 20 may be spaced
20 farther apart than typical fiducials 12, changes in orientation and/or position of a referenced item will have a greater effect on the pattern created by the modular fiducials 20 than the pattern created by typical fiducials 12 secured to a typical reference structure 8.

 In still other embodiments, modular fiducial 20 may be secured with
25 adhesive, which may or may not be a permanent adhesive. In still other embodiments, stems 80 and fasteners 82 are not necessary to modular fiducial 20. Rather, reflective element 78 may be fixed directly to a surface to be referenced. In some embodiments, instruments may be formed with integral reflective elements 78, with or without stems, in suitable locations
30 to allow the instruments to be tracked by a corresponding tracking system.

 In certain methods of use, once a stabilizer platform 14 has been secured to a desired portion of an individual's anatomy, at least three or

more, modular fiducials 20 are snapped into identified and/or appropriate apertures 30 located on stabilizer platform 14. The pattern formed by modular fiducials 20 is registered in the tracking system by an appropriate method, for instance, by the use of a C-arm to obtain fluoroscopy images and/or by the use of a registration probe. The position and orientation of the desired portion of the individual's anatomy can be tracked in real time. The platform may or may not be associated with other platforms or instruments.

This method can be modified as needed. For instance, if modular fiducials 20 are located on instruments on which the tracking system already has wire frame data or the like, no fluoroscopy images would need to be obtained. Rather, a registration probe could simply be used to enter the modular fiducials 20 pattern into the tracking system.

FIG. 21 shows a tracking system 102 that may utilize modular fiducials 20 to track the orientation and/or position of desired items 104 within the tracking sensor's 106 field of vision. Modular fiducials 20 or typical reference structures 8 may be placed on items 104 to be tracked such that a tracking system 102 can track the position and/or orientation of any desired item in the field of view of the tracking sensor 104. The tracking sensor 104 may relay the position and/or orientation data to a processing functionality 112 which can correlate the data with data obtained from an imaging device 108 and output that data to a suitable output device 110.

Changes and modifications, additions and deletions may be made to the structures recited above and shown in the drawings without departing from the scope or spirit of the invention.

What is claimed is:

1 1. A surgical positioner for supporting items used in surgery, the surgical
2 positioner comprising a platform characterized in that the platform includes
3 structure which is adapted to: (i) contact an individual's skin at least at three
4 points on a surface of the platform; (ii) be biased against the individual's skin
5 by at least two fasteners, each of the fasteners connected to bone of the
6 individual such that at least one of the fasteners is not parallel to at least one
7 other of the fasteners; and (iii) support at least one item by capturing a portion
8 of the item.

1 2. The surgical positioner of Claim 1, further characterized in that the
2 platform includes a plurality of apertures defined by portions of the platform, at
3 least one of the apertures adapted to receive one of the fasteners.

1 3. The surgical positioner of Claim 2, further characterized in that the
2 platform includes a first platform surface and a second platform surface, at
3 least some of the plurality of apertures extending from the first platform
4 surface to the second platform surface, the first platform surface defining a
5 convex surface and the second platform surface defining a concave surface.

1 4. The surgical positioner of Claim 3, further characterized in that at least
2 two of the apertures are each adapted to receive one of the fasteners such
3 that the at least two fasteners received by the apertures converge towards
4 each other.

1 5. The surgical positioner of Claim 4, further characterized in that the at
2 least one item includes at least one fiducial.

1 6. The surgical positioner of Claim 5, further characterized in that the at
2 least one fiducial includes at least one modular fiducial.

1 7. The surgical positioner of Claim 2, further characterized in that at least
2 three of the plurality of apertures defined by portions of the platform are
3 adapted to receive at least three modular fiducials such that the modular
4 fiducials can be received by at least some of the apertures such that the
5 modular fiducials form a pattern, the pattern recognizable by a tracking
6 system such that the tracking system can track the position and orientation of
7 the pattern.

1 8. The surgical positioner of Claim 1, further characterized in that the at
2 least one item includes a drill guide.

1 9. A surgical item positioner for supporting an item used in surgery
2 characterized in that the surgical item positioner includes:
3 (a) a support platform adapted to: (i) contact an individual's skin at
4 least at three points on a surface of the platform; (ii) support at least one item;
5 and (iii) be connected to a stabilizing system; and
6 (b) the stabilizing system, the stabilizing system adapted to: (i)
7 connect to the support platform; (ii) stabilize the support platform; and (iii) be
8 biased against the individual by at least one fastener.

1 10. The surgical item positioner of Claim 9, further characterized in that the
2 stabilizing system comprises:
3 (a) a stabilizer platform, the stabilizer platform adapted to: (i) contact
4 an individual's skin at least at three points on a surface of the stabilizer
5 platform; (ii) be biased against the individual's skin by at least two fasteners
6 such that at least one of the fasteners is not parallel to at least one other of
7 the fasteners; and (iii) be connected to the support platform by an arm; and

8 (b) the arm, the arm adapted to connect the support platform to the
9 stabilizer platform.

1 11. The surgical item positioner of Claim 10, further characterized in that
2 the stabilizer platform is adapted to receive the at least two fasteners such
3 that the at least two fasteners converge towards each other, the at least two
4 fasteners adapted to be secured to the bony anatomy of the individual.

1 12. The surgical item positioner of Claim 11, further characterized in that
2 the arm comprises a flexible arm.

1 13. The surgical item positioner of Claim 9, further characterized in that
2 portions of the support platform define a portal, the portal adapted to receive
3 the at least one item.

1 14. The surgical item positioner of Claim 13, further characterized in that
2 the portal is adapted to interact with a bearing in a rotating fashion, the
3 bearing adapted to interact with portions of the item in a rotating and sliding
4 fashion.

1 15. The surgical item positioner of Claim 14, further characterized in that
2 the bearing further comprises a plurality of protrusions extending from an
3 outer surface of the bearing, at least some of the protrusions adapted to
4 interact with a channel at least partially extending around an interior
5 circumference of the portal.

1 16. A reference for use as a navigational positioner in surgery
2 characterized in that the reference includes:

3 (a) a first modular fiducial secured to a structure;

4 (b) a second modular fiducial secured to the structure, the second
5 modular fiducial positioned at least somewhat independently of the first
6 modular fiducial; and

7 (c) at least one additional modular fiducial secured to the structure,
8 the at least one additional modular fiducial positioned at least somewhat
9 independently of the first modular fiducial and the second modular fiducial,
10 wherein the first, second and at least one additional modular fiducials are
11 positioned in one of a plurality of patterns, some of the patterns recognizable
12 by a tracking system such that the tracking system can track the position and
13 orientation of the pattern.

1 17. The reference of Claim 16, further characterized in that portions of the
2 first, second and at least one additional modular fiducials are captured and
3 supported by a platform adapted to: (i) contact an individual's skin at least at
4 three points on a surface of the platform; and (ii) be biased against the
5 individual's skin by at least two fasteners, each of the fasteners connected to
6 bone of the individual such that at least one of the fasteners is not parallel to
7 at least one other of the fasteners.

1 18. The reference of Claim 17, further characterized in that the first, second
2 and at least one additional modular fiducials are captured and supported by a
3 plurality of apertures defined by the platform.

1 19. The reference of Claim 18, further characterized in that the first, second
2 and at least one additional modular fiducials are secured to a portion of an
3 individual's bony anatomy.

1 20. A method for establishing a reference for use as a navigational
2 positioner in surgery characterized in that the method includes:

3 (a) positioning and securing a first modular fiducial to a structure;

4 (b) positioning and securing a second modular fiducial to the
5 structure, the second modular fiducial able to be positioned at least somewhat
6 independently of the first modular fiducial; and

7 (c) positioning and securing at least one additional modular fiducial
8 to the structure, the at least one additional modular fiducial able to be
9 positioned at least somewhat independently of the first modular fiducial and
10 the second modular fiducial, wherein the first, second and at least one
11 additional modular fiducials are positioned in one of a plurality of patterns,
12 some of the patterns recognizable by a tracking system such that the tracking
13 system can track the position and orientation of the pattern.

1 21. The method of Claim 20, further characterized in that securing the first,
2 second and at least one additional modular fiducials includes securing the
3 first, second and at least one additional modular fiducials to a platform and
4 biasing the platform against an individual's skin.

1 22. The method of Claim 21, further characterized in that biasing the
2 platform against the individual's skin includes biasing the platform against the
3 individual's skin using at least two fasteners, the platform adapted to be
4 biased against the individual's skin by the at least two fasteners such that the
5 at least two fasteners converge towards each other.

1 23. The method of Claim 22, further characterized in that securing the first,
2 second and at least one additional modular fiducials includes inserting ends of
3 the modular fiducials into apertures defined by portions of the platform.

1 24. The method of Claim 23, further characterized in that securing the first,
2 second and at least one additional modular fiducials includes inserting the
3 modular fiducials into apertures associated with identifiers.

1 25. The method of Claim 20, further characterized in that securing the first,
2 second and at least one additional modular fiducial includes securing the first,
3 second and at least one additional modular fiducial to a portion of an
4 individual's bony anatomy.

1 26. The method of Claim 20, further characterized in that the tracking
2 system provides feedback if the pattern created by the first, second and at
3 least one additional modular fiducials is not recognizable by the tracking
4 system.

1 27. The method of Claim 20, further characterized in that the method
2 includes using the tracking system to position an implant relative to an
3 individual and installing the implant.

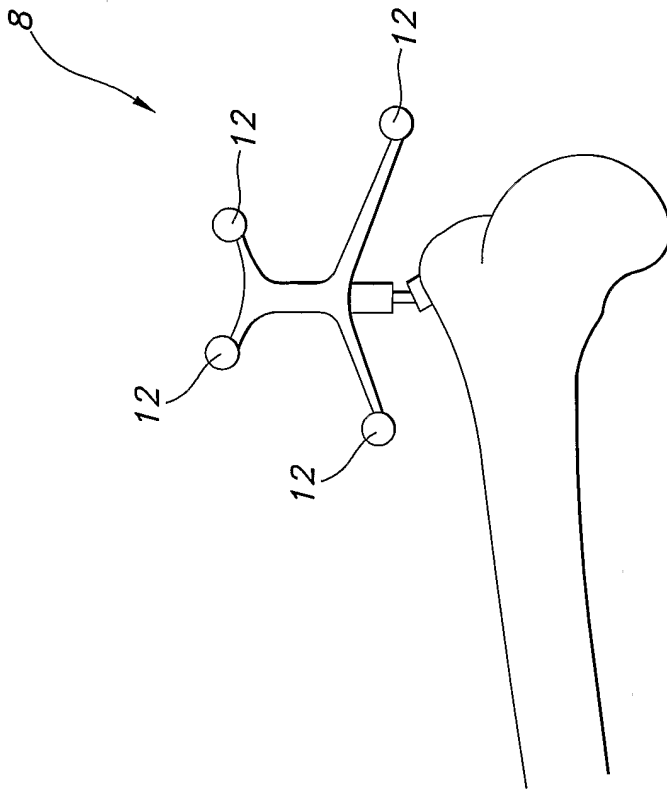

FIG. 1

2/14

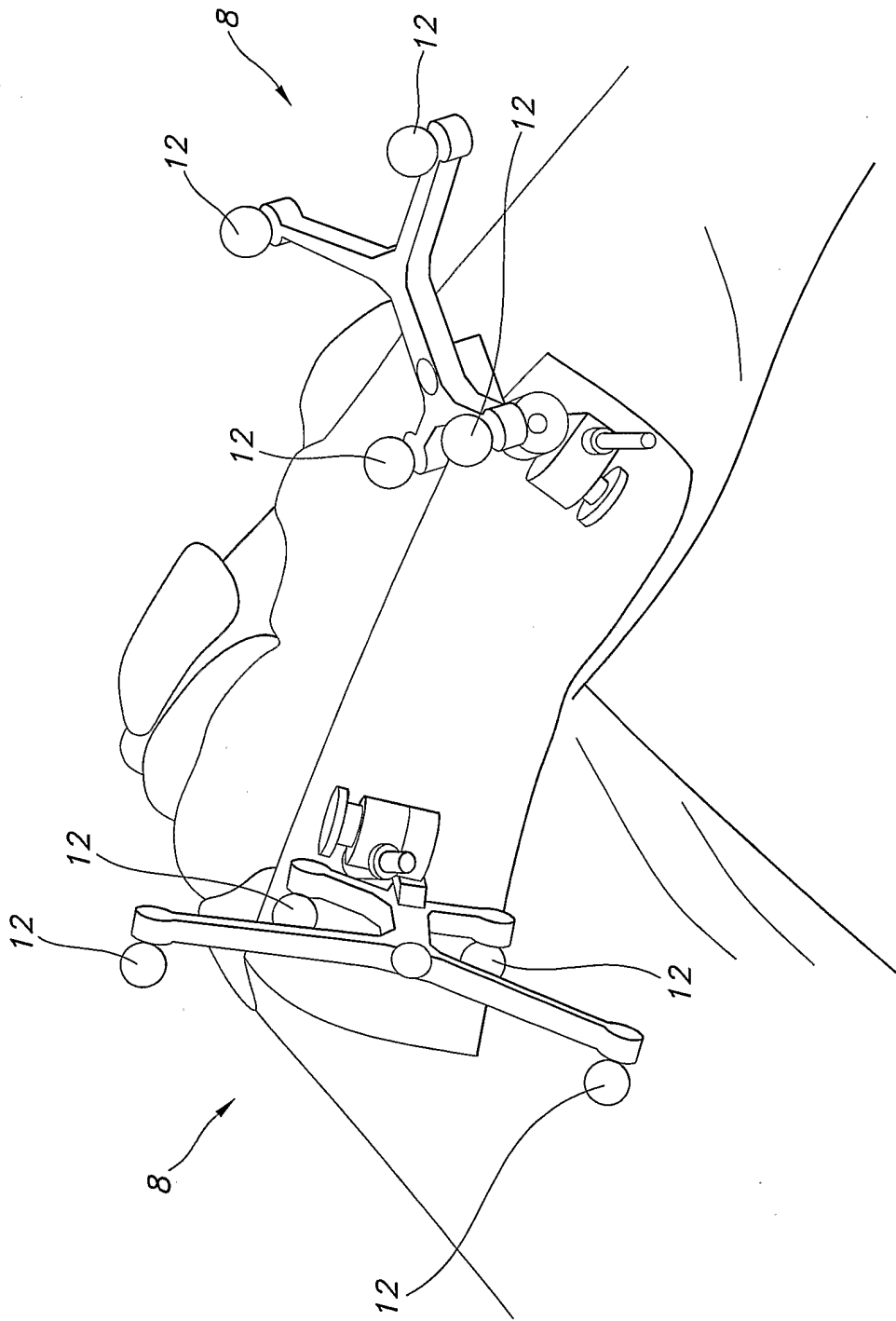

FIG. 2

3/14

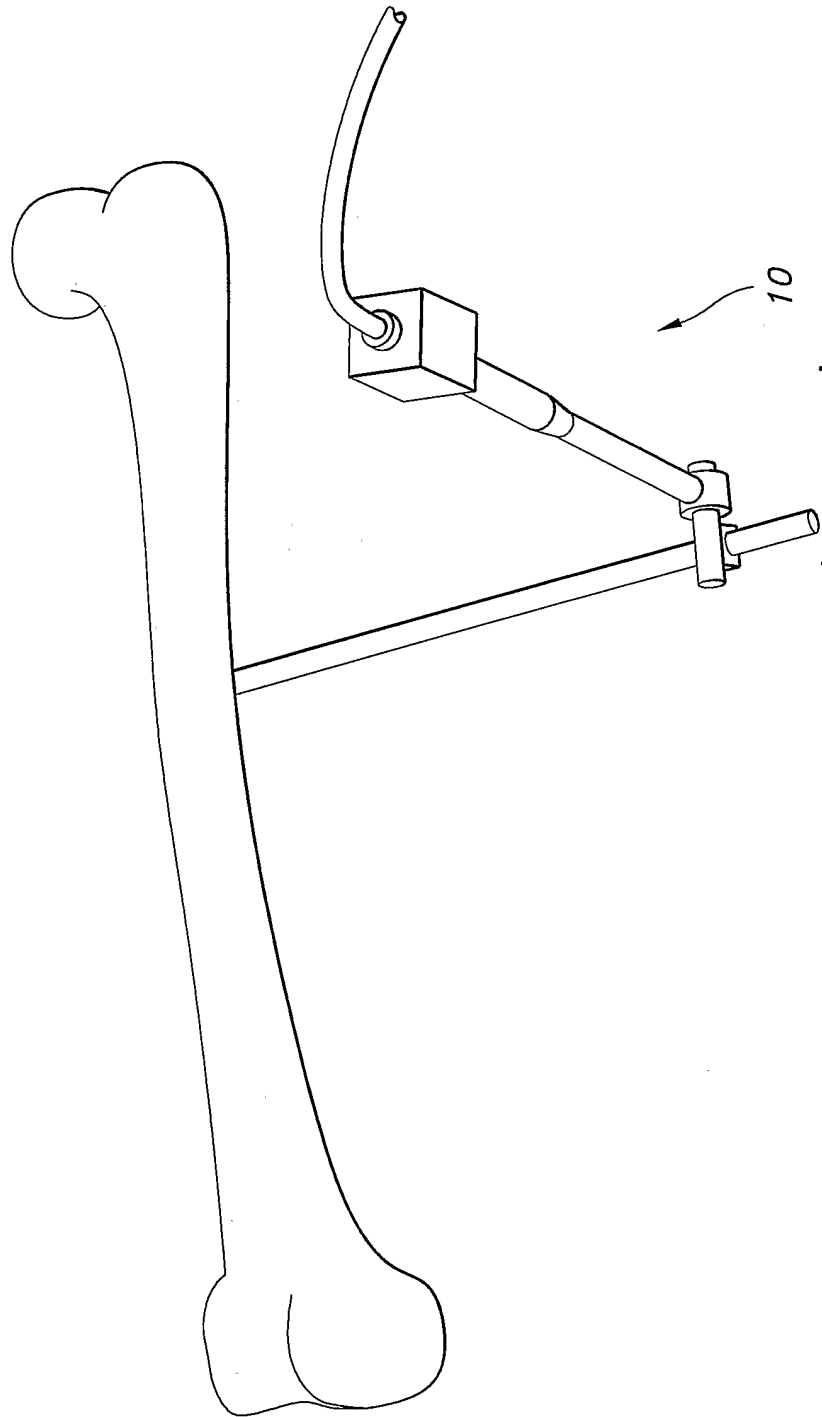

FIG. 3

4/14

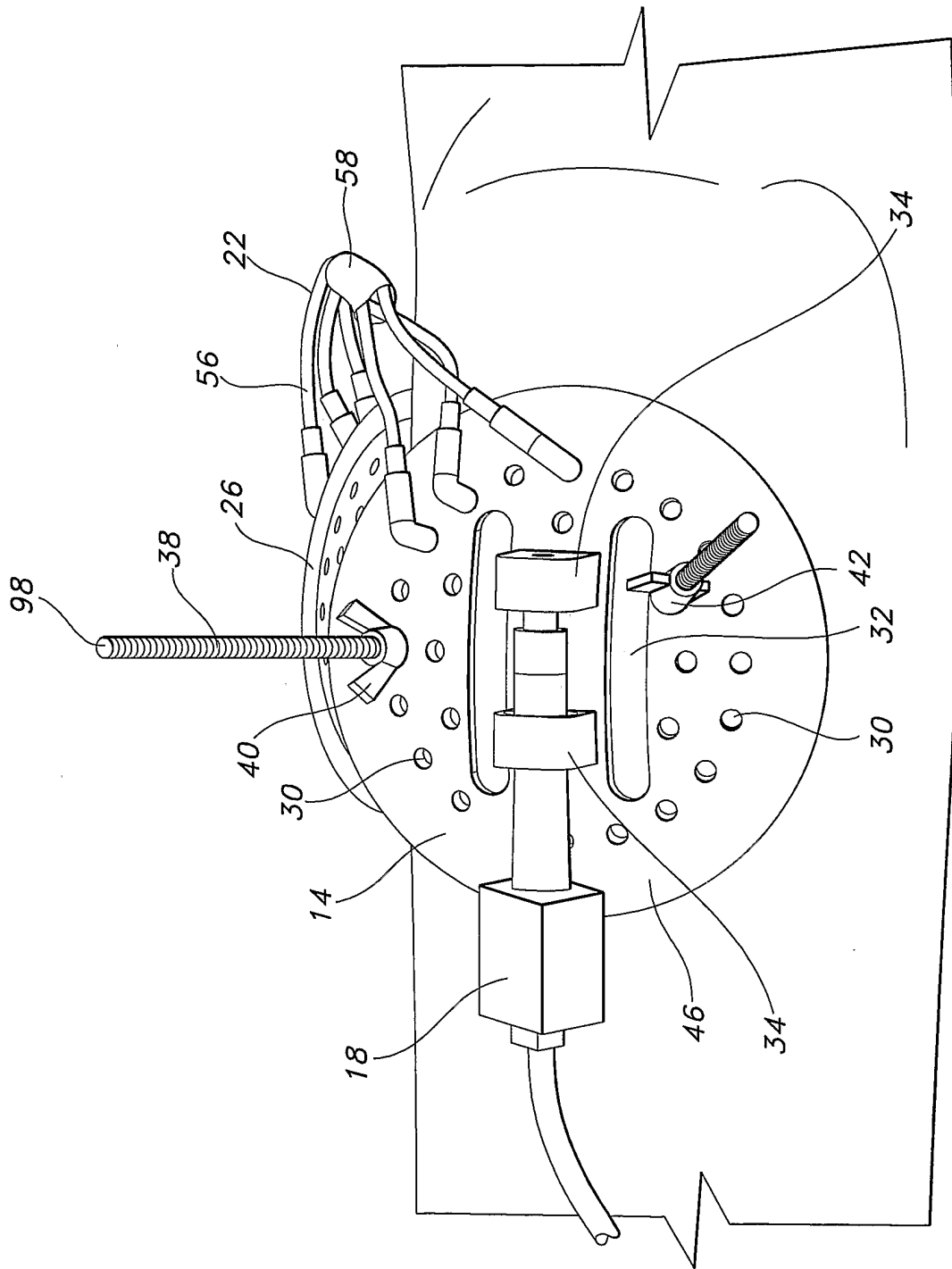

FIG. 4

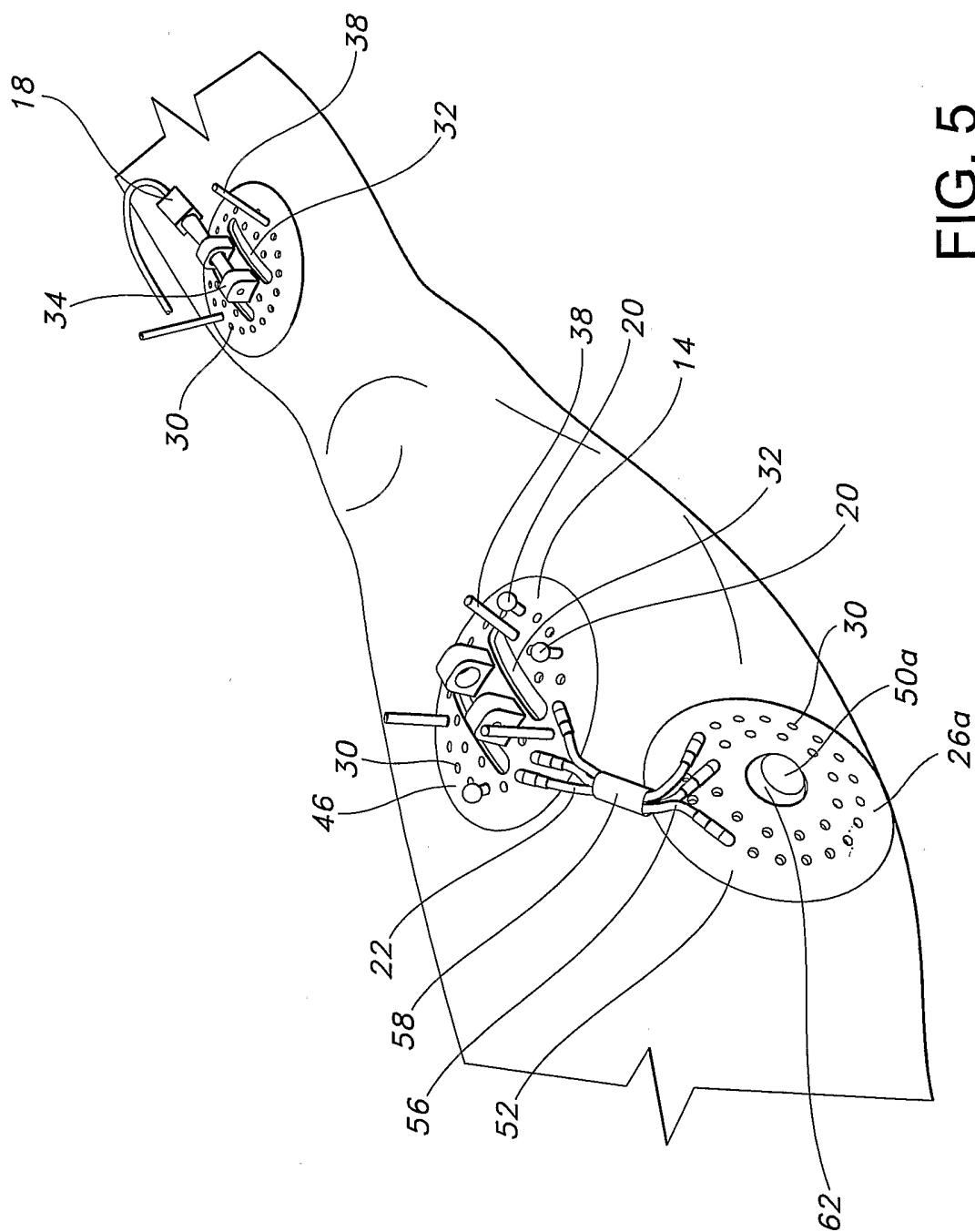

FIG. 5

6/14

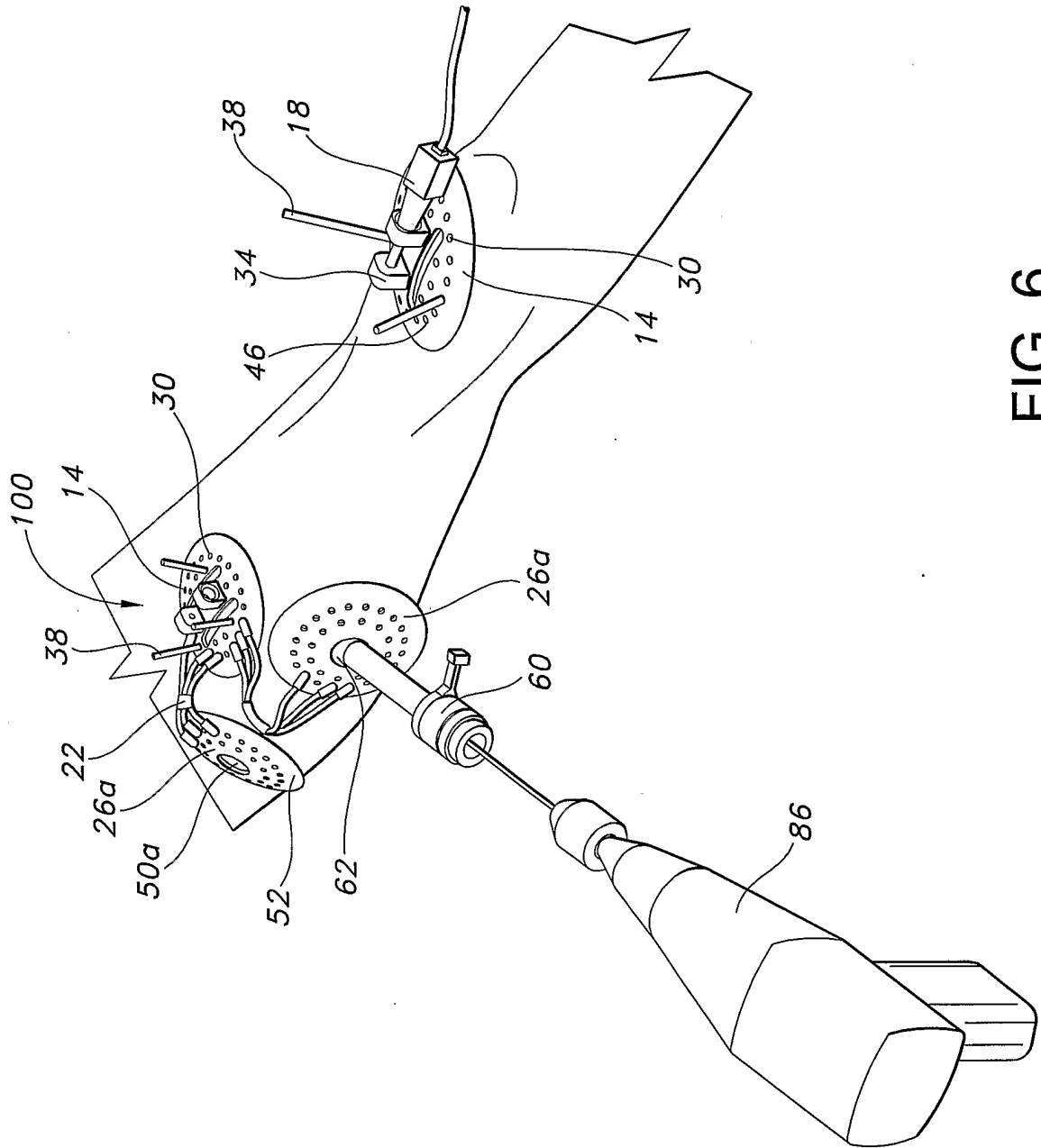

FIG. 6

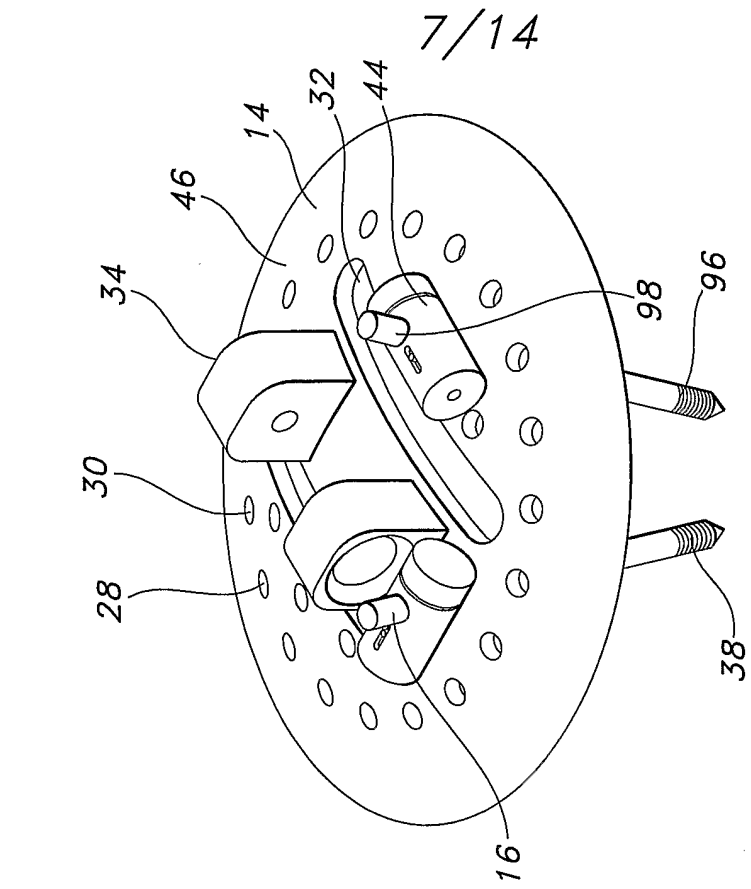

FIG. 8

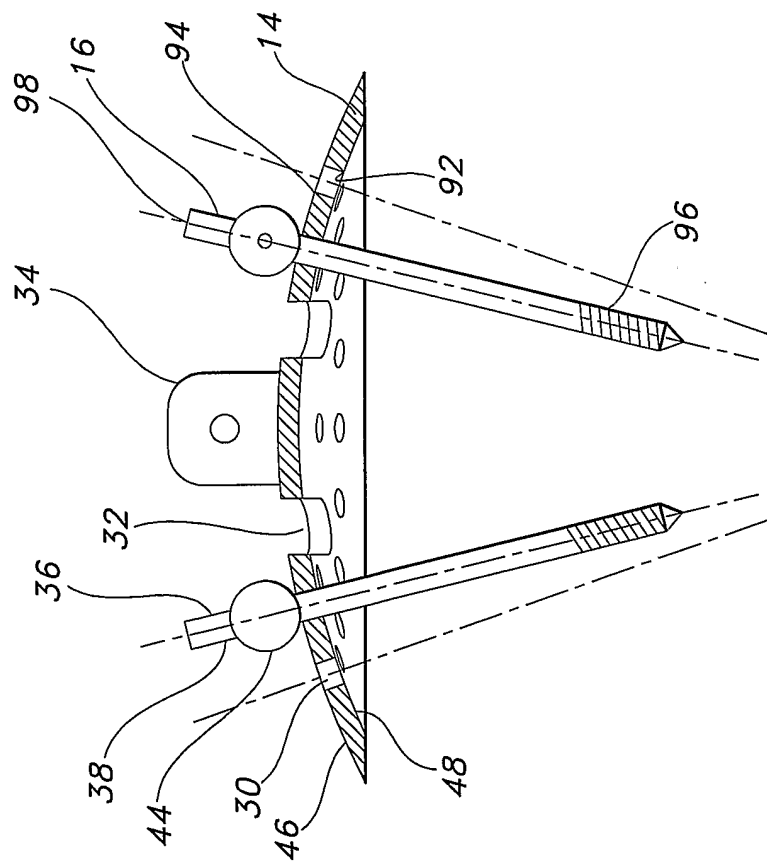

FIG. 7

8/14

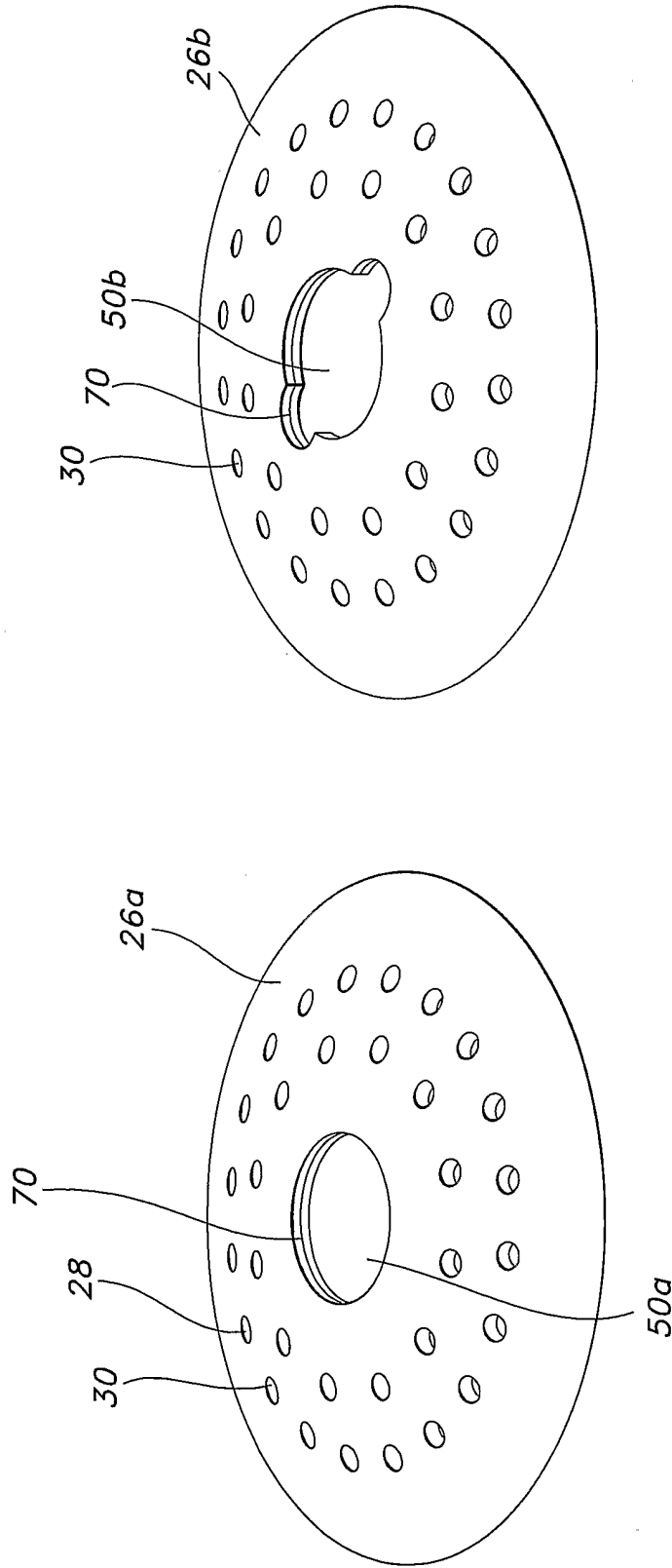

FIG. 10

FIG. 9

9/14

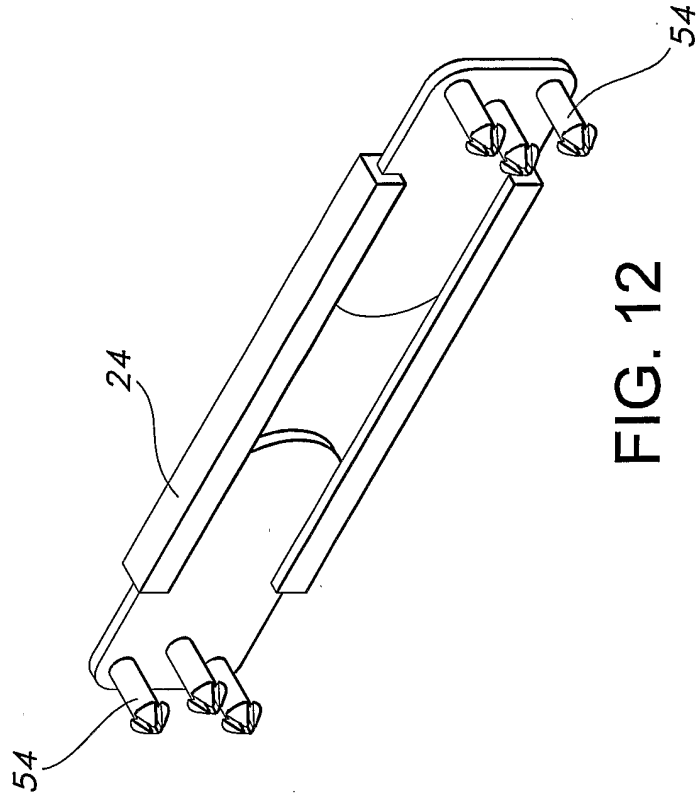

FIG. 12

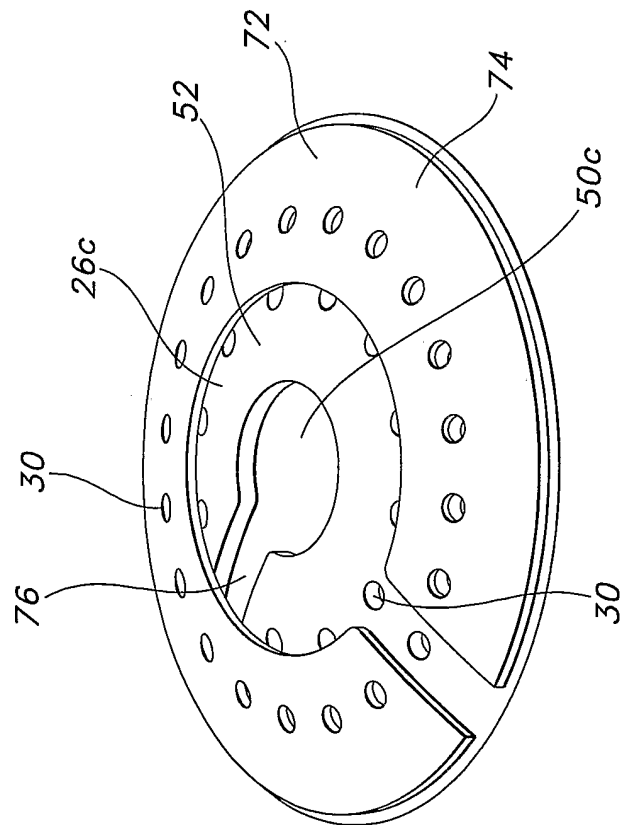

FIG. 11

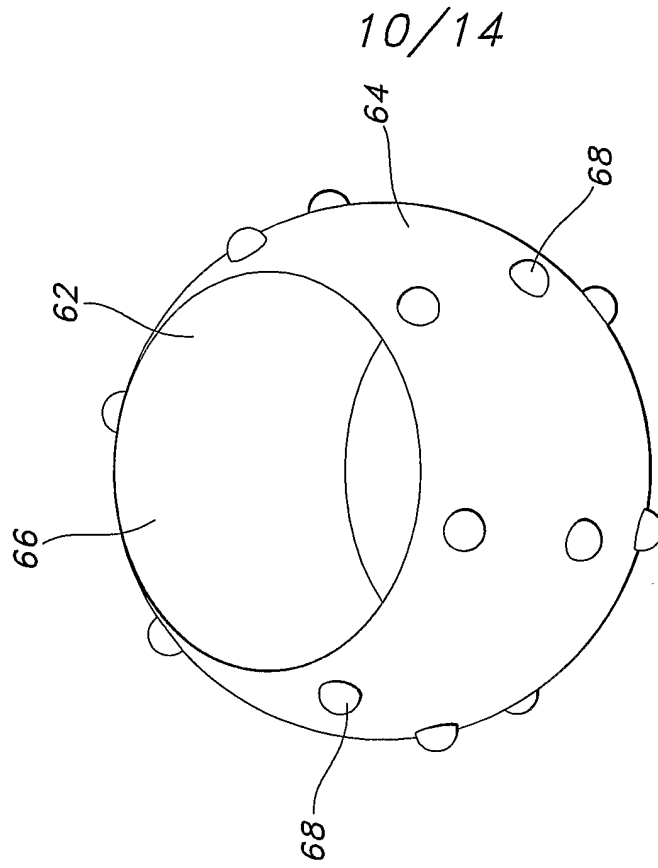

FIG. 14

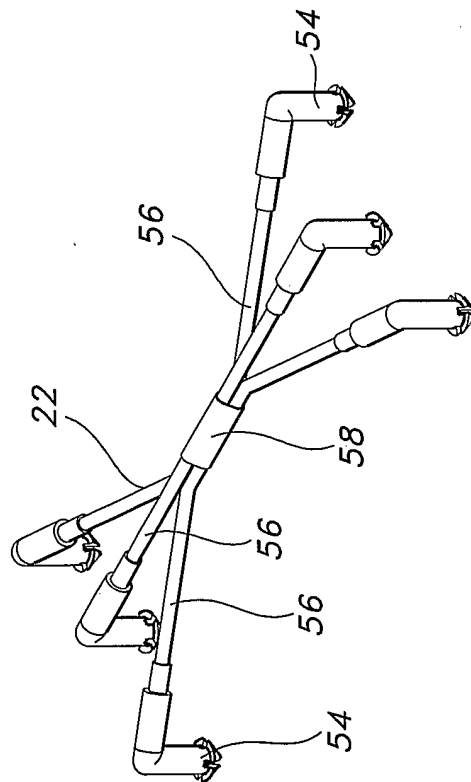

FIG. 13

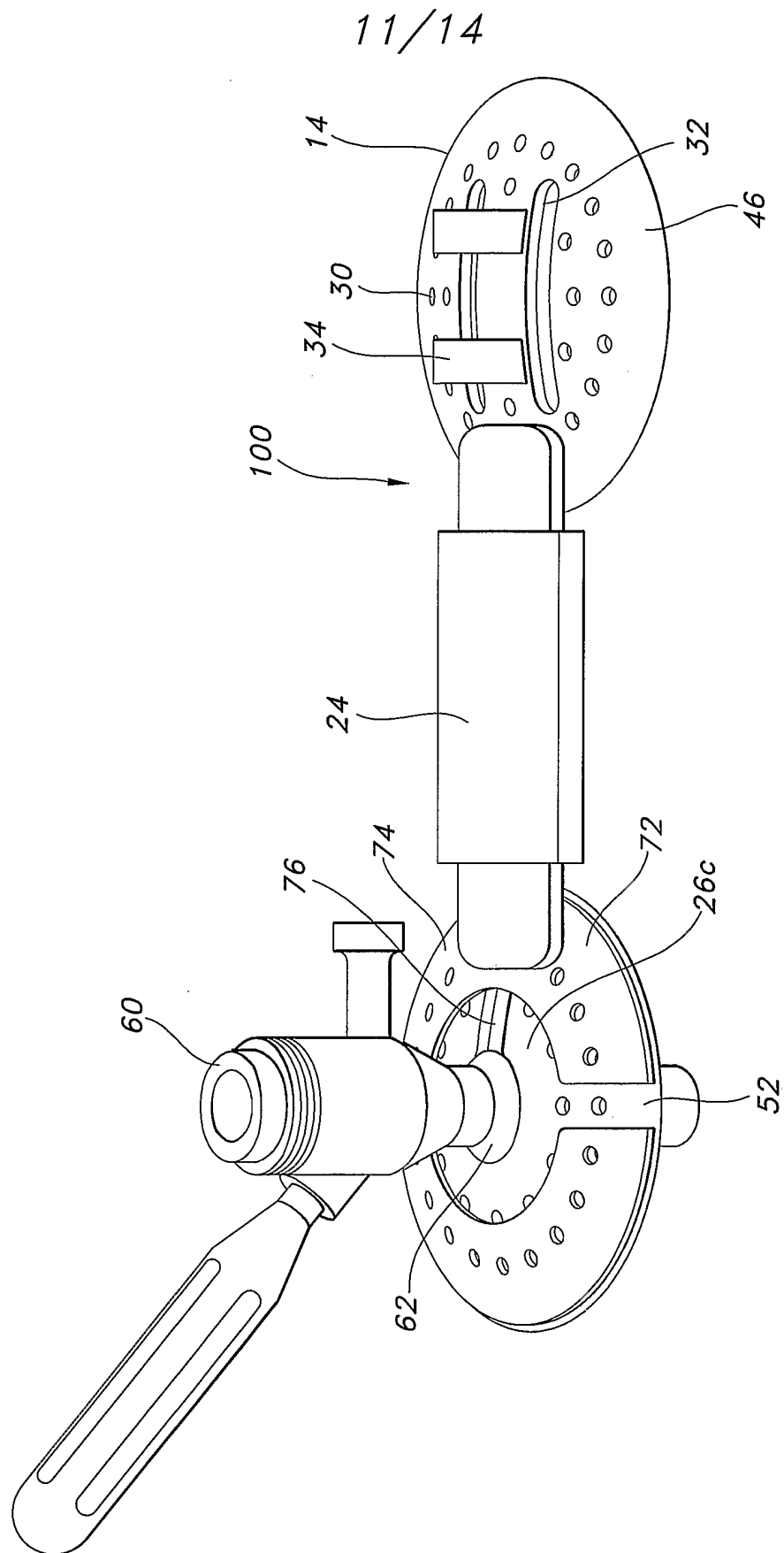

FIG. 15

12/14

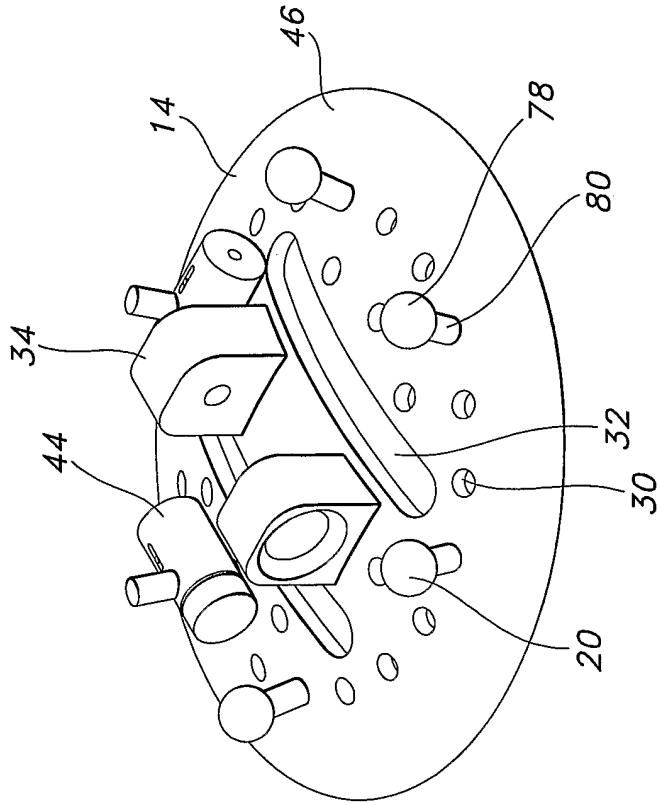

FIG. 17

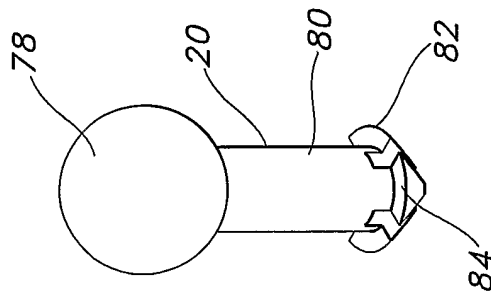

FIG. 16

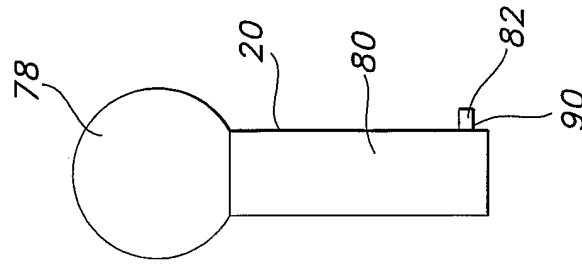

FIG. 20

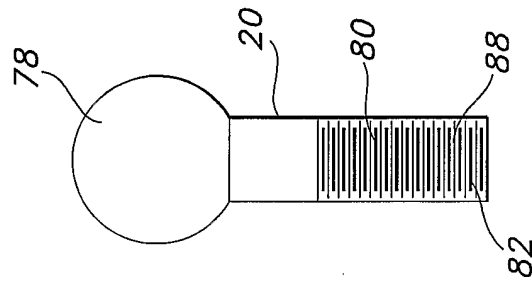

FIG. 19

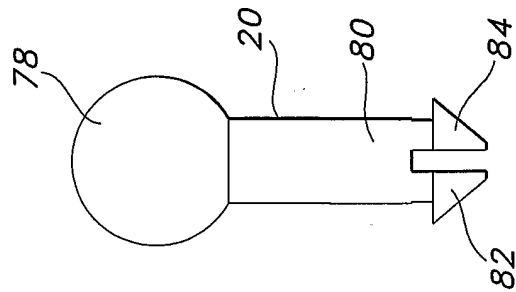

FIG. 18

INTERNATIONAL SEARCH REPORT

International Application No

PCT/US 03/31594

A. CLASSIFICATION OF SUBJECT MATTER
 IPC 7 A61B19/00 A61B17/34

According to International Patent Classification (IPC) or to both national classification and IPC

B. FIELDS SEARCHED
 Minimum documentation searched (classification system followed by classification symbols)
 IPC 7 A61B

Documentation searched other than minimum documentation to the extent that such documents are included in the fields searched

Electronic data base consulted during the international search (name of data base and, where practical, search terms used)
 EPO-Internal

C. DOCUMENTS CONSIDERED TO BE RELEVANT

Category °	Citation of document, with indication, where appropriate, of the relevant passages	Relevant to claim No.
X	US 3 457 922 A (RAY CHARLES D) 29 July 1969 (1969-07-29)	1-4,8
Y	column 2, line 69 - column 3, line 65; figures 1-3,8	5,6
X	----- US 2002/068942 A1 (IMMERZ MARTIN ET AL) 6 June 2002 (2002-06-06)	1,2
Y	page 3, paragraph 33 - paragraph 35; figure 7B	5,6
A	----- US 5 375 588 A (YOON INBAE) 27 December 1994 (1994-12-27)	1,7
A	----- US 2003/187351 A1 (FRANKLIN RONALD J ET AL) 2 October 2003 (2003-10-02)	1
	----- abstract; figures 1-4,10	
	----- abstract; figures 3,7,9,23	
	----- -/--	

Further documents are listed in the continuation of box C. Patent family members are listed in annex.

° Special categories of cited documents :

<p>"A" document defining the general state of the art which is not considered to be of particular relevance</p> <p>"E" earlier document but published on or after the international filing date</p> <p>"L" document which may throw doubts on priority claim(s) or which is cited to establish the publication date of another citation or other special reason (as specified)</p> <p>"O" document referring to an oral disclosure, use, exhibition or other means</p> <p>"P" document published prior to the international filing date but later than the priority date claimed</p>	<p>"T" later document published after the international filing date or priority date and not in conflict with the application but cited to understand the principle or theory underlying the invention</p> <p>"X" document of particular relevance; the claimed invention cannot be considered novel or cannot be considered to involve an inventive step when the document is taken alone</p> <p>"Y" document of particular relevance; the claimed invention cannot be considered to involve an inventive step when the document is combined with one or more other such documents, such combination being obvious to a person skilled in the art.</p> <p>"&" document member of the same patent family</p>
--	--

Date of the actual completion of the international search 1 June 2004	Date of mailing of the international search report 03 SEP 2004
---	--

Name and mailing address of the ISA European Patent Office, P.B. 5818 Patentlaan 2 NL - 2280 HV Rijswijk Tel. (+31-70) 340-2040, Tx. 31 651 epo nl, Fax: (+31-70) 340-3016	Authorized officer Moers, R
--	---

INTERNATIONAL SEARCH REPORT

International Application No

PCT/US 03/31594

C.(Continuation) DOCUMENTS CONSIDERED TO BE RELEVANT

Category °	Citation of document, with indication, where appropriate, of the relevant passages	Relevant to claim No.
A	US 5 865 809 A (MANKER CHARLES ET AL) 2 February 1999 (1999-02-02) abstract; figures 1-3	1
A	----- DE 296 23 941 U (BRAINLAB MED COMPUTERSYST GMBH) 9 November 2000 (2000-11-09) abstract; figures 1-10 -----	7

INTERNATIONAL SEARCH REPORT

International application No.
PCT/US 03/31594

Box I Observations where certain claims were found unsearchable (Continuation of item 1 of first sheet)

This International Search Report has not been established in respect of certain claims under Article 17(2)(a) for the following reasons:

1. Claims Nos.: 20-27
because they relate to subject matter not required to be searched by this Authority, namely:
Rule 39.1(iv) PCT - Method for treatment of the human or animal body by surgery
2. Claims Nos.:
because they relate to parts of the International Application that do not comply with the prescribed requirements to such an extent that no meaningful International Search can be carried out, specifically:
3. Claims Nos.:
because they are dependent claims and are not drafted in accordance with the second and third sentences of Rule 6.4(a).

Box II Observations where unity of invention is lacking (Continuation of item 2 of first sheet)

This International Searching Authority found multiple inventions in this international application, as follows:

see additional sheet

1. As all required additional search fees were timely paid by the applicant, this International Search Report covers all searchable claims.
2. As all searchable claims could be searched without effort justifying an additional fee, this Authority did not invite payment of any additional fee.
3. As only some of the required additional search fees were timely paid by the applicant, this International Search Report covers only those claims for which fees were paid, specifically claims Nos.:
4. No required additional search fees were timely paid by the applicant. Consequently, this International Search Report is restricted to the invention first mentioned in the claims; it is covered by claims Nos.:

1-8

Remark on Protest

- The additional search fees were accompanied by the applicant's protest.
- No protest accompanied the payment of additional search fees.

FURTHER INFORMATION CONTINUED FROM PCT/ISA/ 210

Continuation of Box I.1

Claims Nos.: 20-27

Rule 39.1(iv) PCT - Method for treatment of the human or animal body by surgery

FURTHER INFORMATION CONTINUED FROM PCT/ISA/ 210

This International Searching Authority found multiple (groups of) inventions in this international application, as follows:

1. claims: 1-8

Surgical positioner comprising a platform to contact a skin, said platform adapted to support at least one item and further comprising at least two fasteners to be connected to bone whereby said fasteners are not parallel.

2. claims: 9-15

Surgical positioner comprising a platform to contact a skin, said platform adapted to support at least one item and further comprising a stabilizing system adapted to connect to the platform, said stabilizing system adapted to be biased against an individual by at least one fastener.

3. claims: 16-19

A reference for use in navigation surgery comprising first, second and third fiducials to be secured at independent positions on a structure.

INTERNATIONAL SEARCH REPORT

Information on patent family members

International Application No

PCT/US 03/31594

Patent document cited in search report		Publication date	Patent family member(s)	Publication date
US 3457922	A	29-07-1969	NONE	

US 2002068942	A1	06-06-2002	EP 1190675 A1	27-03-2002
			EP 1190676 A1	27-03-2002
			AT 265185 T	15-05-2004
			AT 246903 T	15-08-2003
			DE 50006264 D1	03-06-2004
			DE 50100485 D1	18-09-2003
			ES 2203556 T3	16-04-2004
			US 2002038085 A1	28-03-2002
			DE 20103416 U1	05-07-2001
			US 2002107518 A1	08-08-2002

US 5375588	A	27-12-1994	WO 9404067 A1	03-03-1994
			US 5540648 A	30-07-1996

US 2003187351	A1	02-10-2003	US 6546277 B1	08-04-2003
			US 6273896 B1	14-08-2001
			US 6529765 B1	04-03-2003
			US 2001027271 A1	04-10-2001
			US 6282437 B1	28-08-2001
			US 6351662 B1	26-02-2002

US 5865809	A	02-02-1999	NONE	

DE 29623941	U	09-11-2000	DE 19639615 A1	09-04-1998
			DE 29623941 U1	09-11-2000
			US 2002095081 A1	18-07-2002
			US 6351659 B1	26-02-2002
