



(19) **United States**
(12) **Patent Application Publication**
Ambichl et al.

(10) **Pub. No.: US 2012/0047490 A1**
(43) **Pub. Date: Feb. 23, 2012**

(54) **ARCHITECTURE FOR STATE DRIVEN TESTING**

Publication Classification

(75) Inventors: **Ernst Ambichl**, Altenberg (AT);
Dietmar Strasser,
Weisskirchen/Traun (AT)

(51) **Int. Cl.**
G06F 9/44 (2006.01)
(52) **U.S. Cl.** **717/125; 717/124**

(73) Assignee: **Micro Focus (US), Inc.**, Rockville,
MD (US)

(57) **ABSTRACT**

(21) Appl. No.: **12/890,547**

An architecture for a test script editor that can be used by anybody in the development team, including non-programmer business analyst testers. Software testers can generate test scripts for validating and verifying software without navigating all possible actions or keywords. The current application state is described with one or more test objects. Each test object has one or more associated test methods and each test method can describe one or more state transitions. Only test methods accessible through test objects in the current application state are displayed to the software tester. The current state changes only if the state transition described by the test method selected by the software tester indicates a change from the current state.

(22) Filed: **Sep. 24, 2010**

Related U.S. Application Data

(63) Continuation of application No. 12/861,794, filed on Aug. 23, 2010, Continuation of application No. 12/861,801, filed on Aug. 23, 2010.

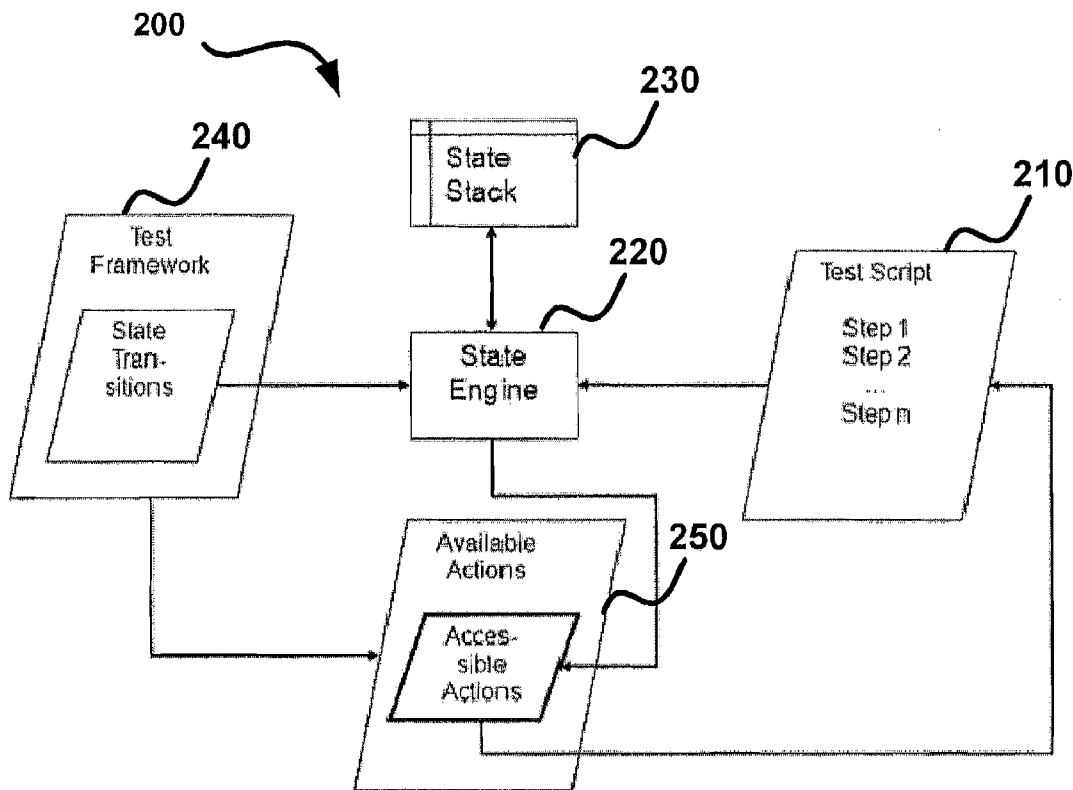

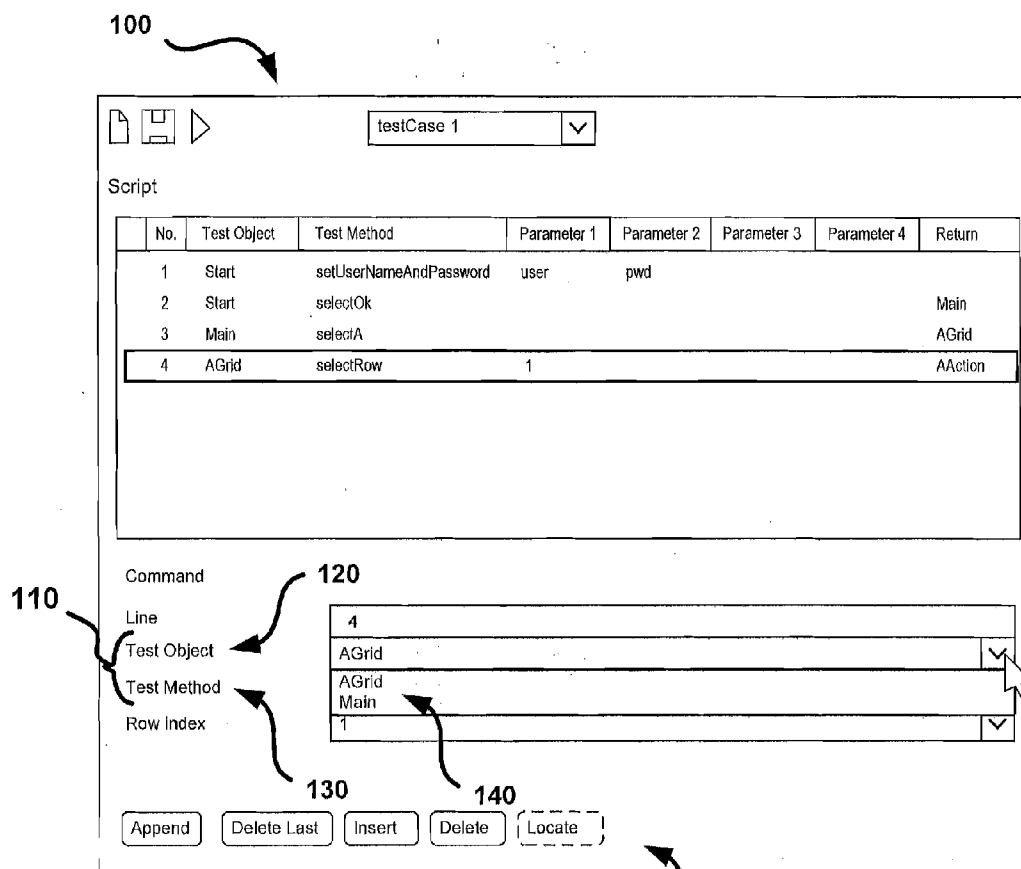

FIG. 1

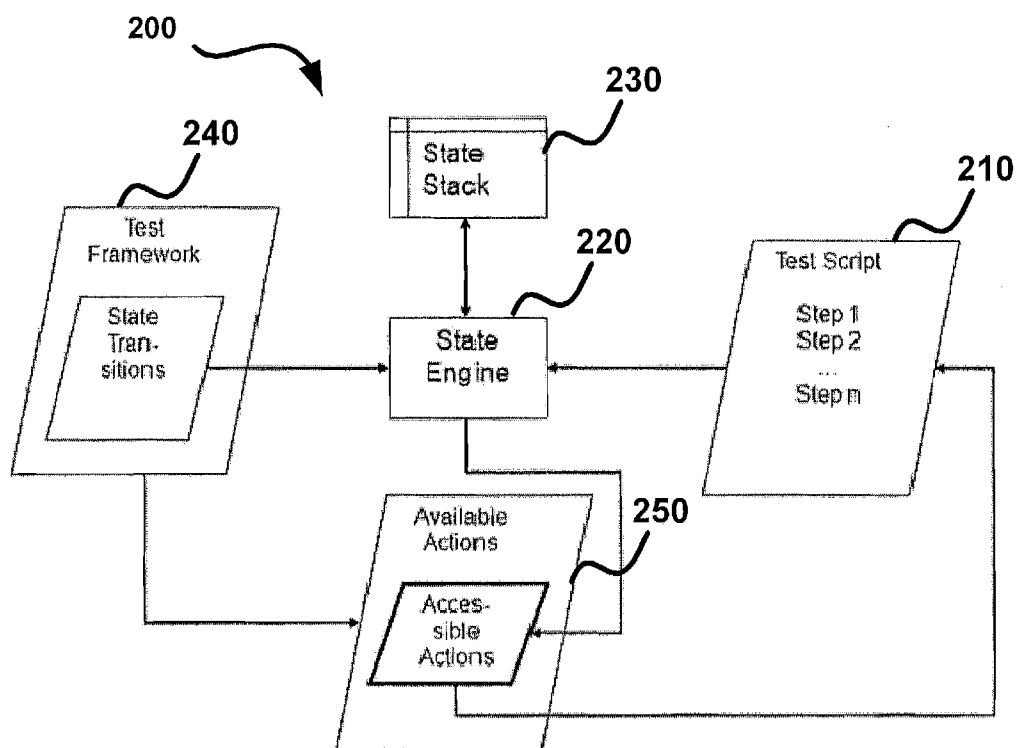

FIG. 2

```
TestObjectList getAccessibleTestObjects(StateStack stack, TestStep[] script,
                                       int firstStep, int lastStep)
{
    for (int i=firstStep; i<=lastStep; i++) // for all steps of a test script
    {
        TestStep step = script[i];
        TestObject to = step.getTestObject();
        TestMethod tm = step.getTestMethod();

        // Retrieve the list of state transitions which are defined for the test
        // method in the test framework
        StateTransitionList stList =
            GetStateTransitionList(TestFramework, to, tm);

        // for all StateTransitions st in StateTransitionList
        for (StateTransition st : stList)
        {
            if (st.type==RestoreAppState) { 310
                stack.pop();
            }
            if (st.type==SetAppState) { 320
                stack.pop();
                stack.push(st.testObjects);
            }
            if (st.type==AddAppState) { 330
                TestObjectList testObjects=stack.pop();
                testObjects.add(st.testObjects);
                stack.push(testObjects);
            }
            if (st.type==RemoveAppState) { 340
                TestObjectList testObjects=stack.pop();
                testObjects.remove(st.testObjects);
                stack.push(testObjects);
            }
            if (st.type==NewAppState) { 350
                stack.push(st.testObjects);
            }
        }
    }
    return stack.pop();
}
```

FIG. 3

300

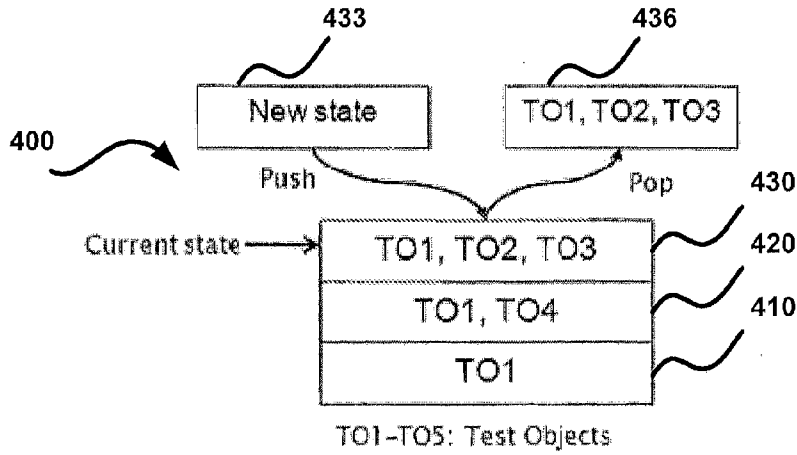

FIG. 4A

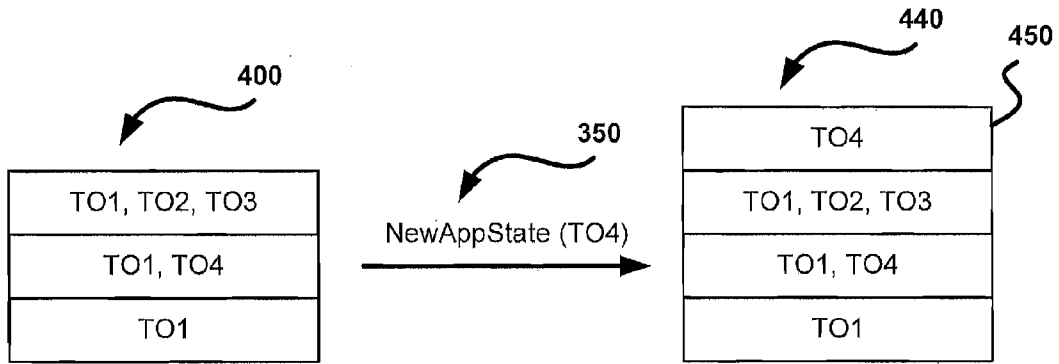

FIG. 4B

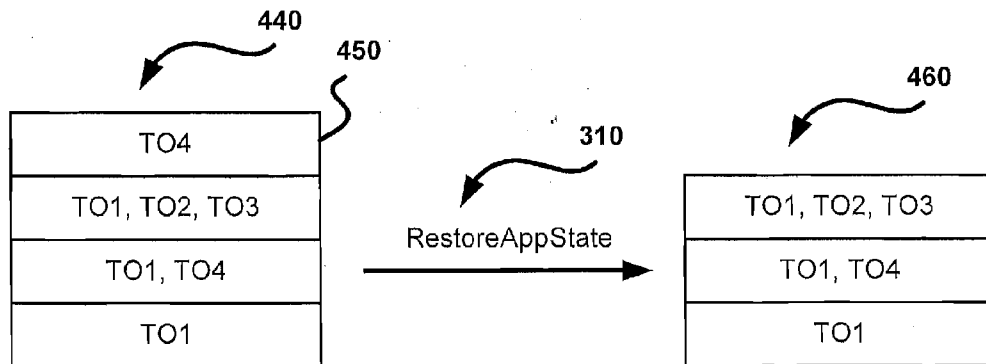

FIG. 4C

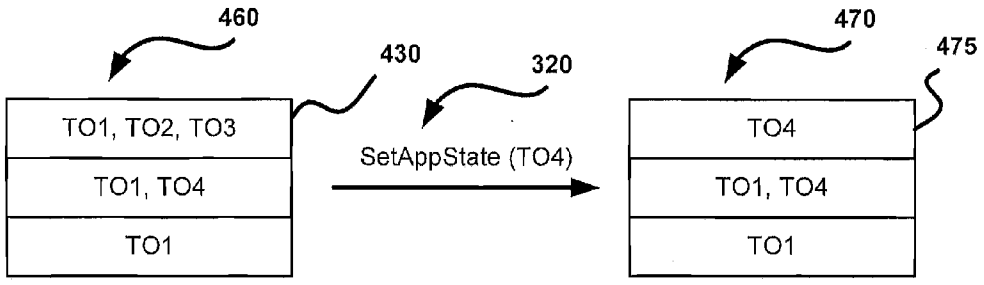

FIG. 4D

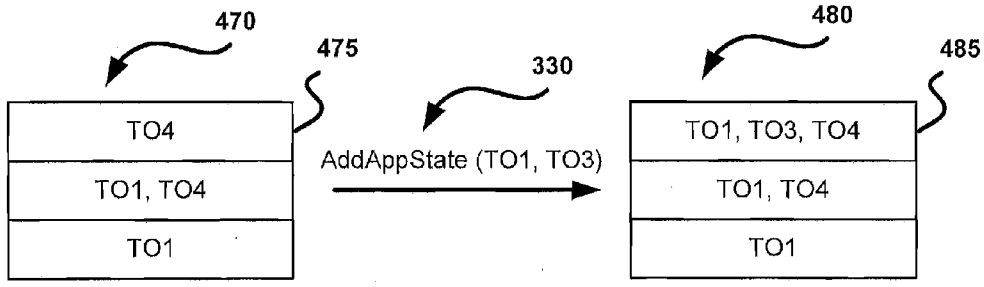

FIG. 4E

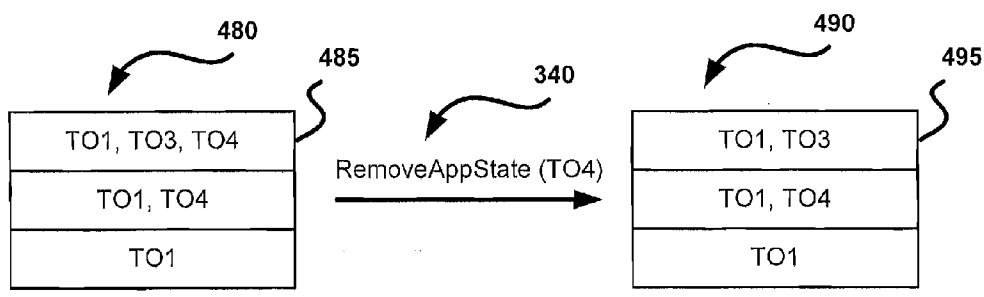

FIG. 4F

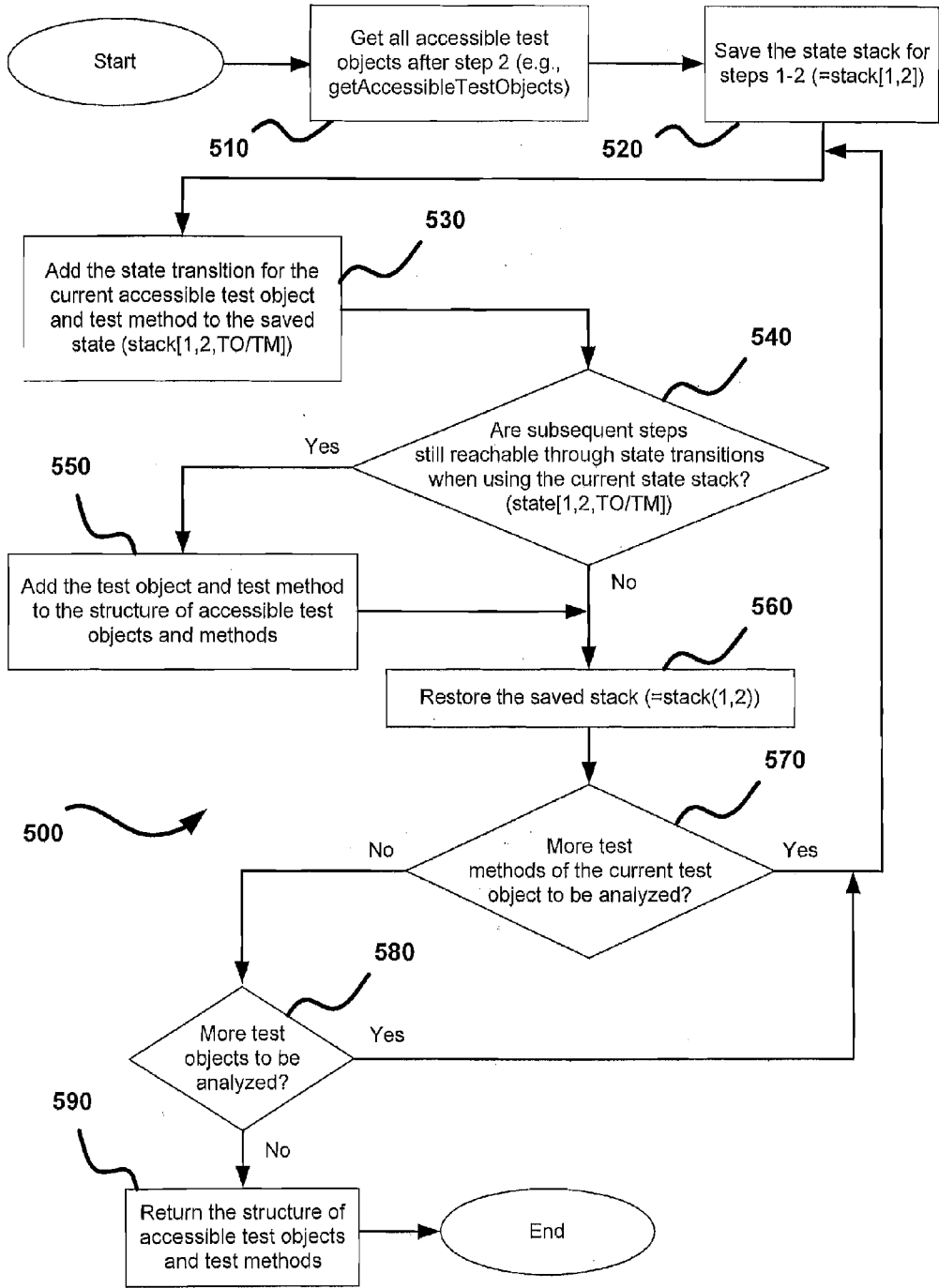

FIG. 5

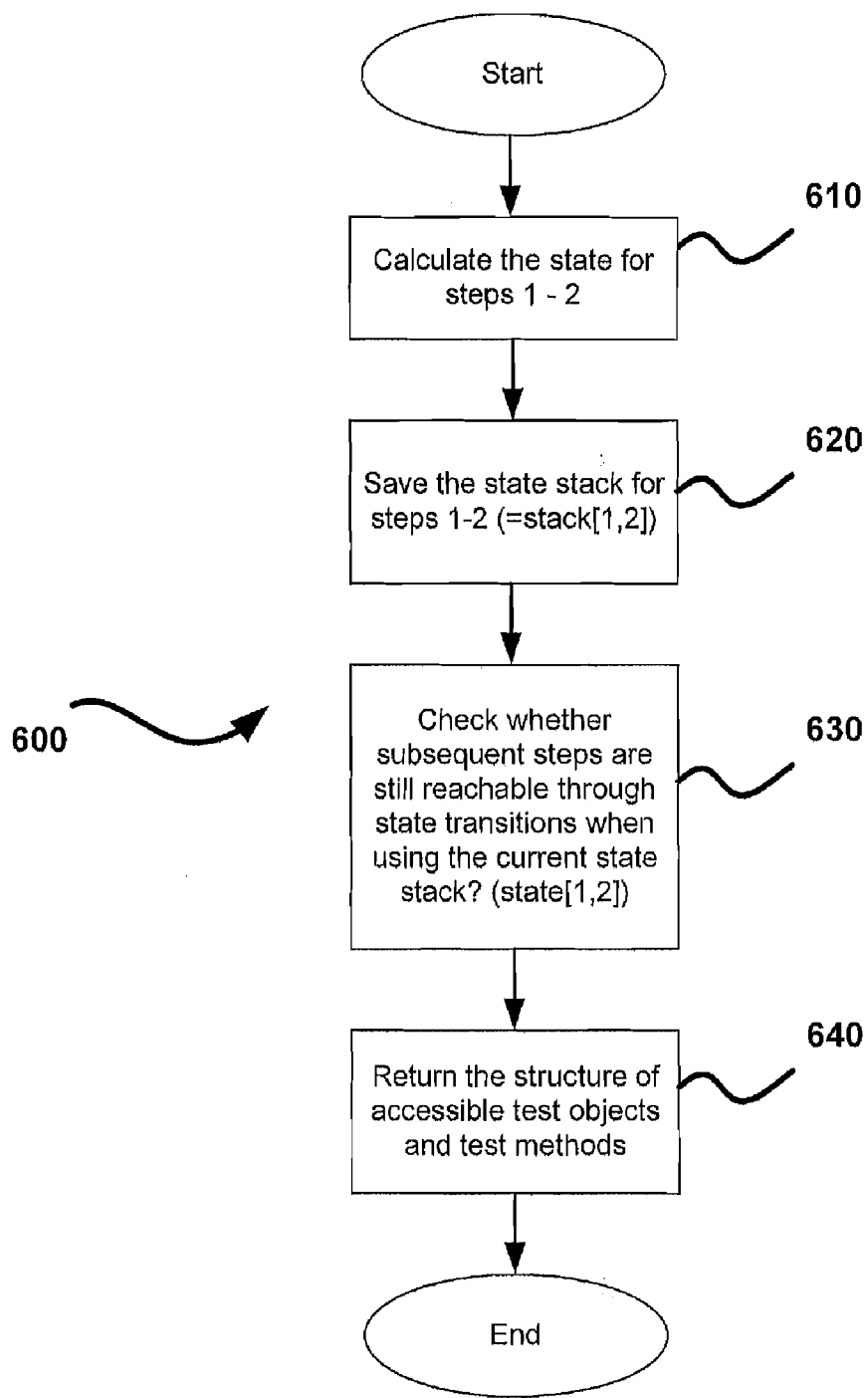

FIG. 6

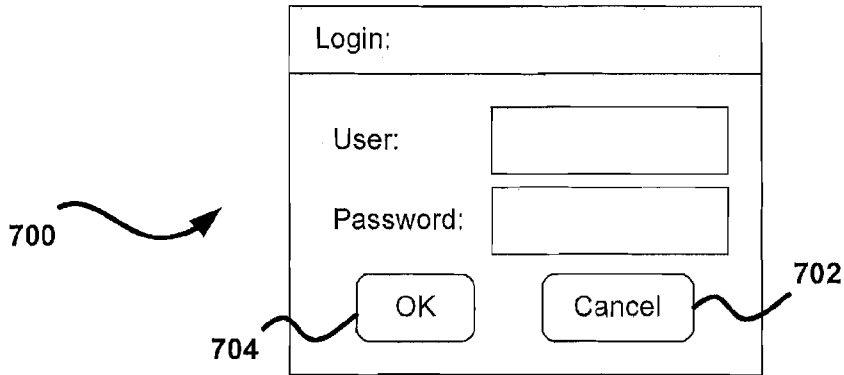

FIG. 7A

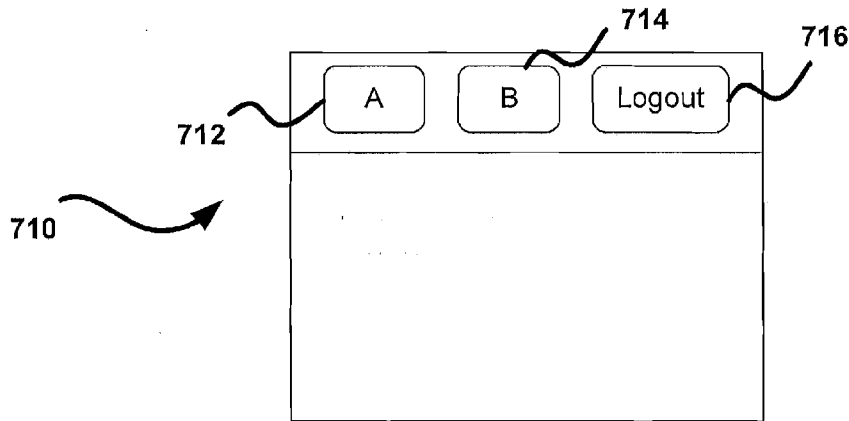

FIG. 7B

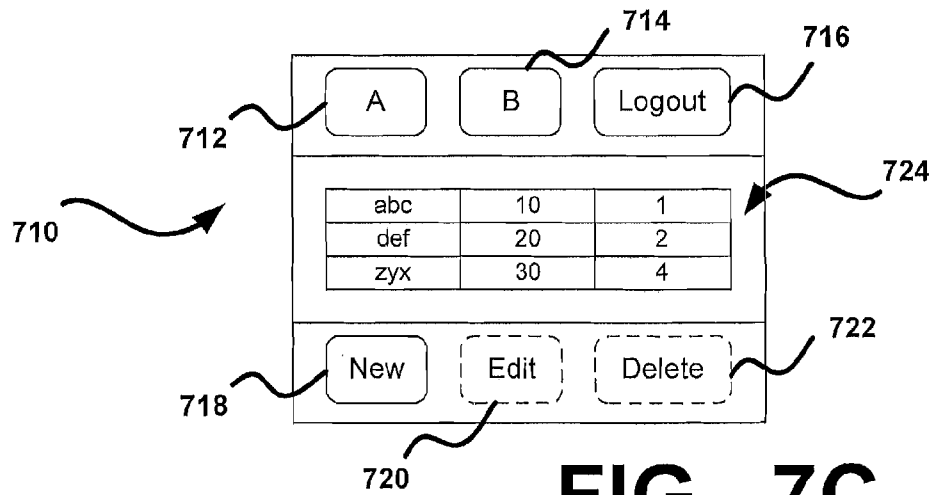
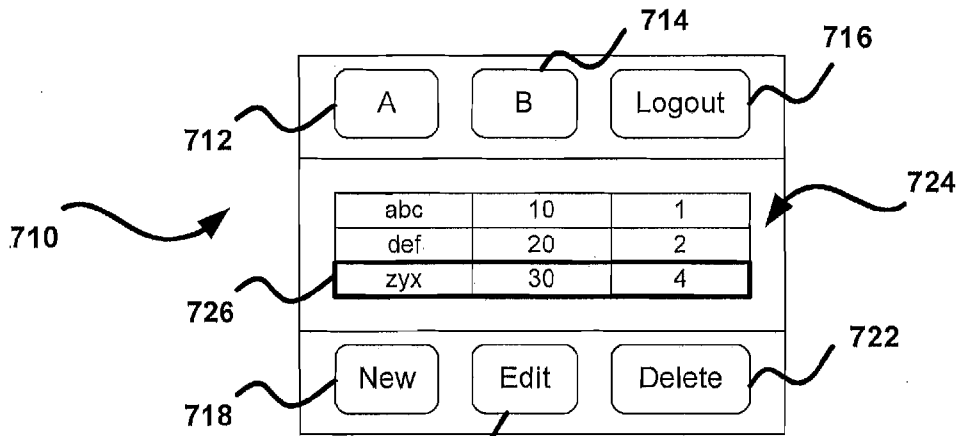

FIG. 7C



720 **FIG. 7D**

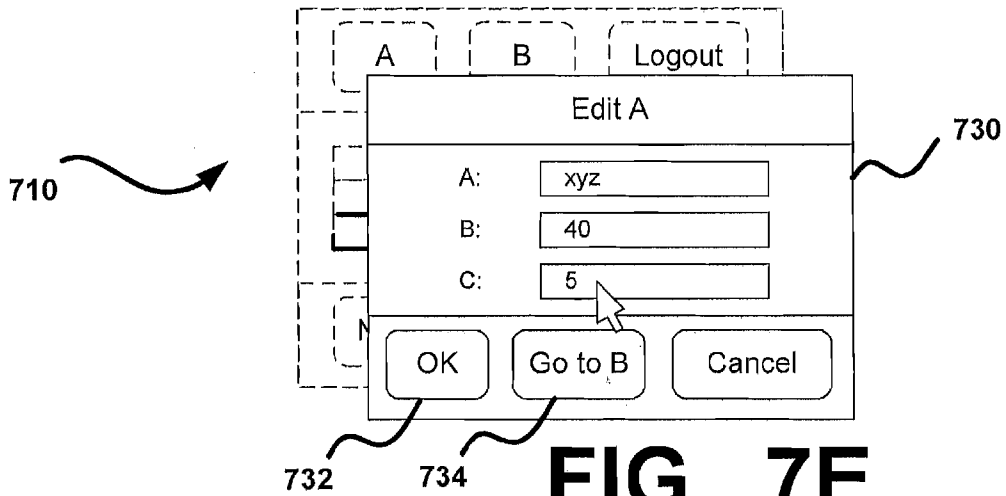

FIG. 7E

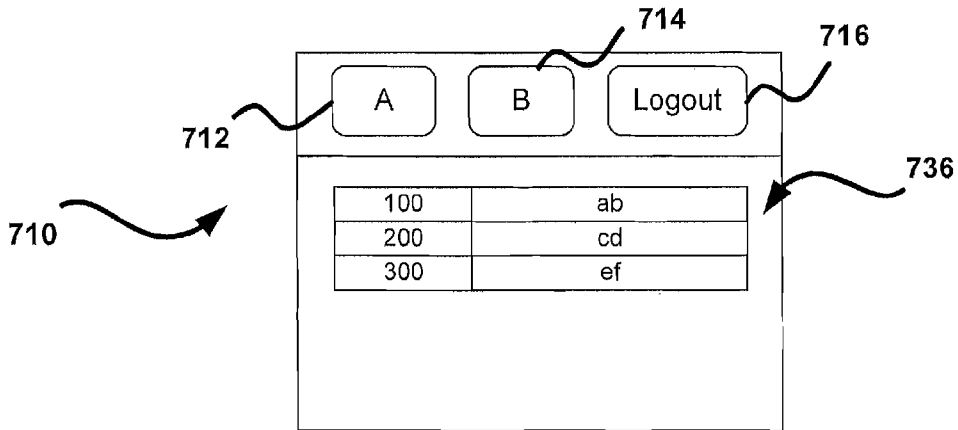

FIG. 7F

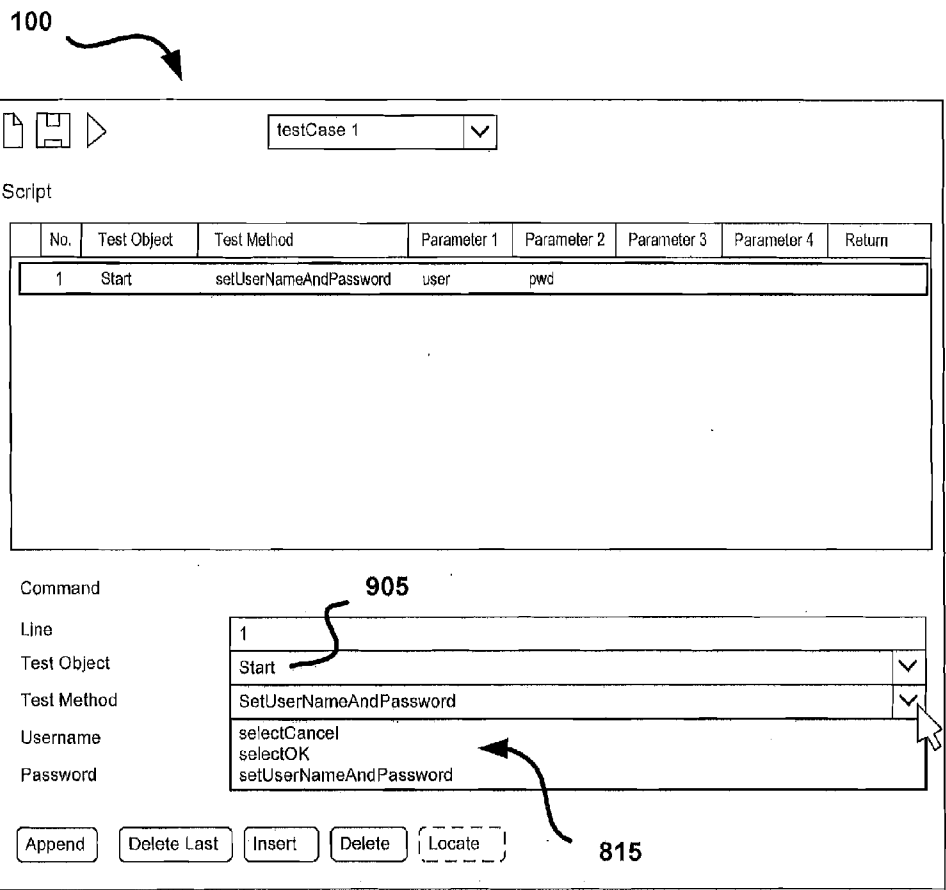

FIG. 9A

100

testCase 1

Script

No.	Test Object	Test Method	Parameter 1	Parameter 2	Parameter 3	Parameter 4	Return
1	Start	setUserNameAndPassword	user	pwd			
2	Start	selectOk					Main

Command

905

Line	2	
Test Object	Start	▼
Test Method	selectOK	▼
Username	selectCancel	
Password	selectOK	
	setUserNameAndPassword	

815

Append Delete Last Insert Delete Locate

FIG. 9B

100

testCase 1

Script

No.	Test Object	Test Method	Parameter 1	Parameter 2	Parameter 3	Parameter 4	Return
1	Start	setUserNameAndPassword	user	pwd			
2	Start	selectOk					Main
3	Main	selectA					AGrid

Command

Line: 3

Test Object: Main

Test Method: selectA

selectA
selectB
selectLogout

Append Delete Last Insert Delete Locate

825

FIG. 9C

100

testCase 1

Script

No.	Test Object	Test Method	Parameter 1	Parameter 2	Parameter 3	Parameter 4	Return
1	Start	setUserNameAndPassword	user	pwd			
2	Start	selectOk					Main
3	Main	selectA					AGrid
4	AGrid	selectRow	1				AAction

Command

Line

Test Object

Test Method

Row index

4

AGrid

AGrid

Main

Append Delete Last Insert Delete Locate

915

910

FIG. 9D

100

testCase 1

Script

No.	Test Object	Test Method	Parameter 1	Parameter 2	Parameter 3	Parameter 4	Return
1	Start	setUserNameAndPassword	user	pwd			
2	Start	selectOk					Main
3	Main	selectA					AGrid
4	AGrid	selectRow	1				AAction
5	AAction	selectEdit					AEditDialog

Command

Line: 5

Test Object: AAction

Test Method: AAction

Row Index: Main

920

915

910

Append Delete Last Insert Delete Locate

FIG. 9E

100

testCase 1

Script

No.	Test Object	Test Method	Parameter 1	Parameter 2	Parameter 3	Parameter 4	Return
1	Start	setUserNameAndPassword	user	pwd			
2	Start	selectOk					Main
3	Main	selectA					AGrid
4	AGrid	selectRow	1				AAction
5	AAction	selectEdit					AEditDialog
6	AEditDialog	setColumn1	hello				

Command

Line

Test Object

Test Method

Parameter 1

925

6

AEditDialog

setColumn1

selectCancel

selectOK

selectOkAndGotoB

setColumn1

setColumn2

setColumn3

Append

Delete Last

855

FIG. 9F

100

testCase 1

Script

No.	Test Object	Test Method	Parameter 1	Parameter 2	Parameter 3	Parameter 4	Return
1	Start	setUserNameAndPassword	user	pwd			
2	Start	selectOk					Main
3	Main	selectA					AGrid
4	AGrid	selectRow	1				AAction
5	AAction	selectEdit					AEditDialog
6	AEditDialog	setColumn1	hello				
7	AEditDialog	selectOkAndGotoB					BGrid

Command

Line: 7

Test Object: AEditDialog

Test Method: selectOkAndGotoB

selectCancel
selectOK
selectOkAndGotoB
setColumn1
setColumn2
setColumn3

Append Delete Last

925

855

FIG. 9G

100

testCase 1

Script

No.	Test Object	Test Method	Parameter 1	Parameter 2	Parameter 3	Parameter 4	Return
1	Start	setUserNameAndPassword	user	pwd			
2	Start	selectOk					Main
3	Main	selectA					AGrid
4	AGrid	selectRow	1				AAction
5	AAction	selectEdit					AEditDialog
6	AEditDialog	setColumn1	hello				
7	AEditDialog	selectOkAndGotoB					BGrid
8	Main	selectLogout					Start

Command

Line

Test Object

Test Method

930

910

Append Delete Last Insert Delete Locate

FIG. 9H

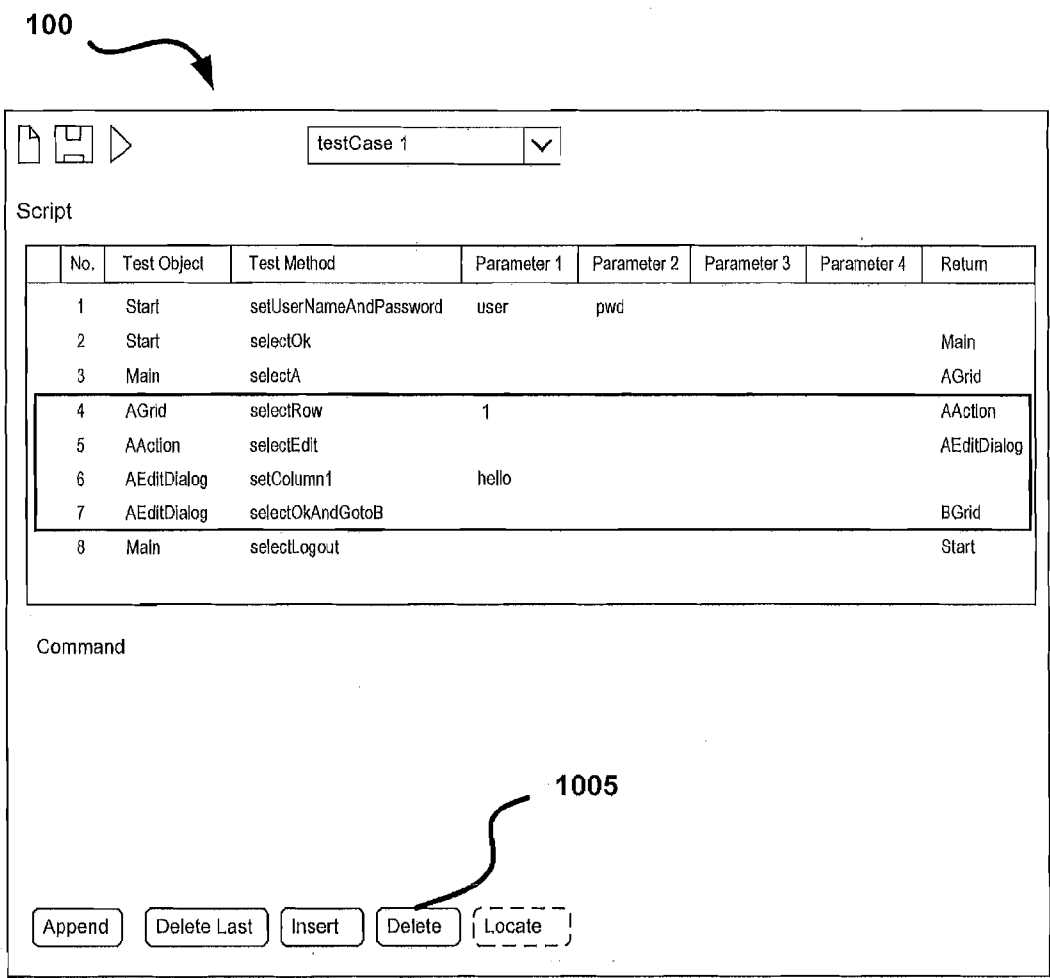

FIG. 10

100

The screenshot shows a software interface for editing a test case. At the top, there are icons for file operations and a dropdown menu showing 'testCase 1'. Below this is a 'Script' section containing a table with 8 rows of test steps. The table has columns for 'No.', 'Test Object', 'Test Method', 'Parameter 1', 'Parameter 2', 'Parameter 3', 'Parameter 4', and 'Return'. The fourth row is highlighted with a thick border. Below the table is a 'Command' section with five buttons: 'Append', 'Delete Last', 'Insert', 'Delete', and 'Locate'. The 'Delete' and 'Locate' buttons are shown with dashed borders. A label '1005' with a curved arrow points to the 'Delete' button.

No.	Test Object	Test Method	Parameter 1	Parameter 2	Parameter 3	Parameter 4	Return
1	Start	setUserNameAndPassword	user	pwd			
2	Start	selectOk					Main
3	Main	selectA					AGrid
4	AGrid	selectRow	1				AAction
5	AAction	selectEdit					AEditDialog
6	AEditDialog	setColumn1	hello				
7	AEditDialog	selectOkAndGotoB					BGrid
8	Main	selectLogout					Start

FIG. 11

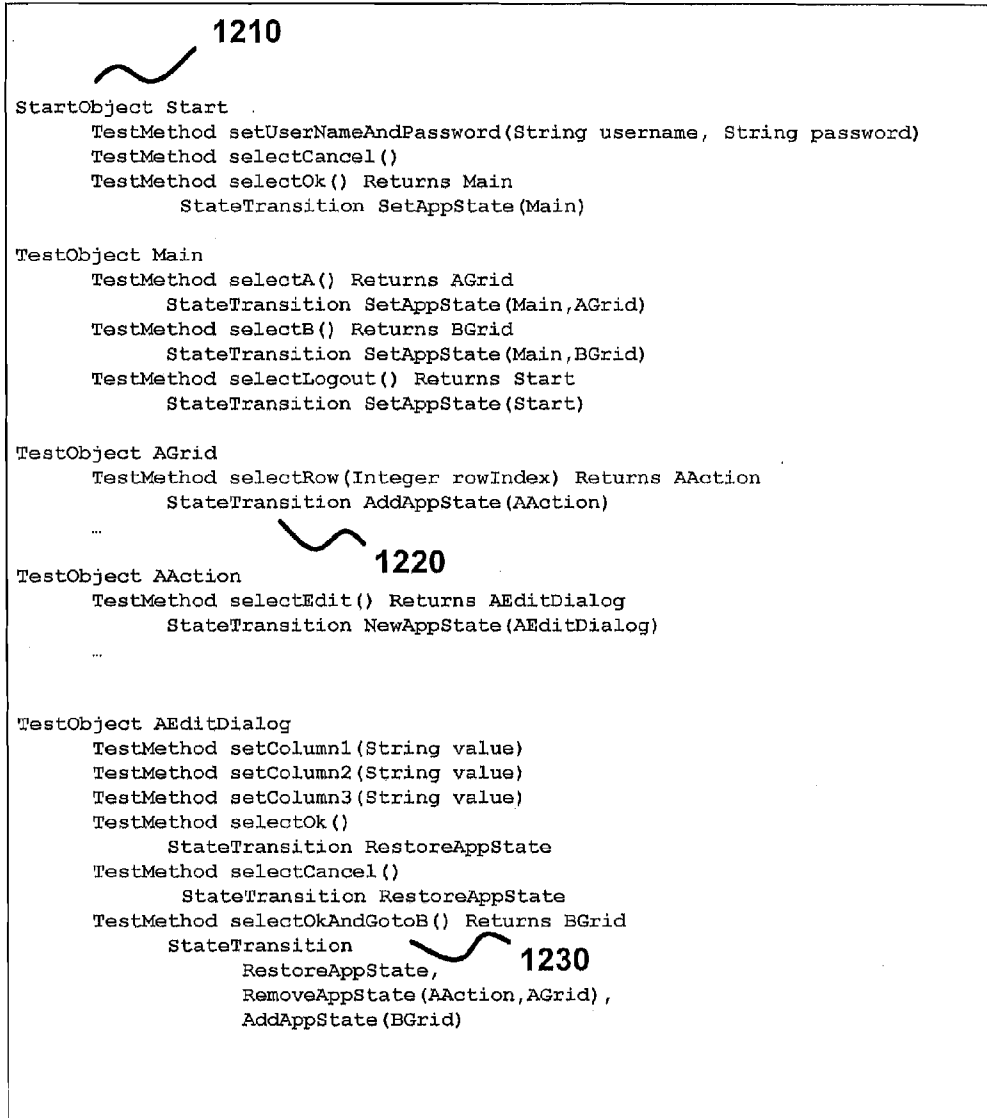

FIG. 12A

1200

```

@StartObject
public class Start {
    public void setUsernameAndPassword (String username, String password) {
        // Implementation Code of Test Method setUsernameAndPassword }
    public void selectCancel() {
        // Implementation Code of Test Method selectCancel }
    @SetAppState(Main.class)
    public void selectOk() {
        // Implementation Code of Test Method selectOk }
    }
public class Main {
    @SetAppState({Main.class,AGrid.class})
    public void selectA() {
        // Implementation Code of Test Method }
    @SetAppState({Main.class,BGrid.class})
    public void selectB() {
        // Implementation Code of Test Method }
    @SetAppState(Start.class)
    public void selectLogout() {
        // Implementation Code of Test Method }
    }
public class AGrid {
    @AddAppState(AAction.class)
    public void selectRow(int rowIndex) {
        // Implementation Code of Test Method }
    ...
}
public class AAction {
    @NewAppState(AEditDialog.class)
    public void selectEdit() {
        // Implementation Code of Test Method }
    ...
}
public class AEditDialog {
    public void setColumn1(String value) {
        // Implementation Code of Test Method }
    public void setColumn2(String value) {
        // Implementation Code of Test Method }
    public void setColumn3(String value) {
        // Implementation Code of Test Method }
    @RestoreAppState
    public void selectOk() {
        // Implementation Code of Test Method }
    @RestoreAppState
    public void selectCancel() {
        // Implementation Code of Test Method }
    @RestoreAppState
    @RemoveAppState({AAction.class,AGrid.class})
    @AddAppState(BGrid.class)
    public void selectOkAndGotoB() {
        // Implementation Code of Test Method }
    ...
}
}

```

FIG. 12B

1240

```
[StartObject]
public class Start {
    public void setUsernameAndPassword (String username, String password) {
        // Implementation Code of Test Method setUsernameAndPassword }
    public void selectCancel() {
        // Implementation Code of Test Method selectCancel }
    [SetAppState(Main.class)]
    public void selectOk() {
        // Implementation Code of Test Method selectOk }
}

public class Main {
    [SetAppState(typeof(Main), typeof(AGrid))]
    public void selectA() {
        // Implementation Code of Test Method }
    [SetAppState(typeof(Main), typeof(BGrid))]
    public void selectB() {
        // Implementation Code of Test Method }
    [SetAppState(typeof(Start)]
    public void selectLogout() {
        // Implementation Code of Test Method }
}

public class AGrid {
    [AddAppState(typeof(AAction)]
    public void selectRow(int rowIndex) {
        // Implementation Code of Test Method }
    ...
}

public class AAction {
    [NewAppState(typeof(AEditDialog)]
    public void selectEdit() {
        // Implementation Code of Test Method }
    ...
}

public class AEditDialog {
    public void setColumn1(String value) {
        // Implementation Code of Test Method }
    public void setColumn2(String value) {
        // Implementation Code of Test Method }
    public void setColumn3(String value) {
        // Implementation Code of Test Method }
    [RestoreAppState]
    public void selectOk() {
        // Implementation Code of Test Method }
    [RestoreAppState]
    public void selectCancel() {
        // Implementation Code of Test Method }
    [RestoreAppState]
    [RemoveAppState(typeof(AAction, typeof(AGrid))]
    [AddAppState(typeof(BGrid))]
    public void selectOkAndGotoB () {
        // Implementation Code of Test Method }
    ...
}
}
```

FIG. 12C

```
<StartObject name="Start">
  <TestMethod name="setUserNameAndPassword">
    <Parameters>
      <Parameter name="username" />
      <Parameter name="password" />
    </Parameters>
  </TestMethod>
  <TestMethod name="selectCancel" />
  <TestMethod name="selectOk">
    <StateTransitions>
      <SetAppState testObjectList="Main" />
    </StateTransitions>
  </TestMethod>
</StartObject>

<TestObject name="Main">
  <TestMethod name="selectA">
    <StateTransitions>
      <SetAppState testObjectList="Main,AGrid" />
    </StateTransitions>
  </TestMethod>

  <TestMethod name="selectB">
    <StateTransitions>
      <SetAppState testObjectList="Main,BGrid" />
    </StateTransitions>
  </TestMethod>
  <TestMethod name="selectLogout">
    <StateTransitions>
      <SetAppState testObjectList="Start" />
    </StateTransitions>
  </TestMethod>
</TestObject>

<TestObject name="AGrid">
  <TestMethod name="selectRow">
    <Parameters>
      <Parameter name="rowIndex" />
    </Parameters>
    <StateTransitions>
      <AddAppState testObjectList="AAction" />
    </StateTransitions>
  </TestMethod>
  ...
</TestObject>

<TestObject name="AAction">
  <TestMethod name="selectEdit">
    <StateTransitions>
      <NewAppState testObjectList="AEditDialog" />
    </StateTransitions>
  </TestMethod>
  ...
</TestObject>
```

FIG. 12D

1260

```
<TestObject name="AEditDialog">
  <TestMethod name="setColumn1">
    <Parameters>
      <Parameter name="value" />
    </Parameters>
  </TestMethod>

  <TestMethod name="setColumn2">
    <Parameters>
      <Parameter name="value" />
    </Parameters>
  </TestMethod>

  <TestMethod name="setColumn3">
    <Parameters>
      <Parameter name="value" />
    </Parameters>
  </TestMethod>

  <TestMethod name="selectOk">
    <StateTransitions>
      <RestoreAppState/>
    </StateTransitions>
  </TestMethod>

  <TestMethod name="selectCancel">
    <StateTransitions>
      <RestoreAppState/>
    </StateTransitions>
  </TestMethod>

  <TestMethod name="selectOkAndGotoB">
    <StateTransitions>
      <RestoreAppState/>
      <RemoveAppState testObjectList="AAction,AGrid" />
      <AddAppState testObjectList="BGrid" />
    </StateTransition>
  </TestMethod>

  ...
</TestObject>
```

FIG. 12E

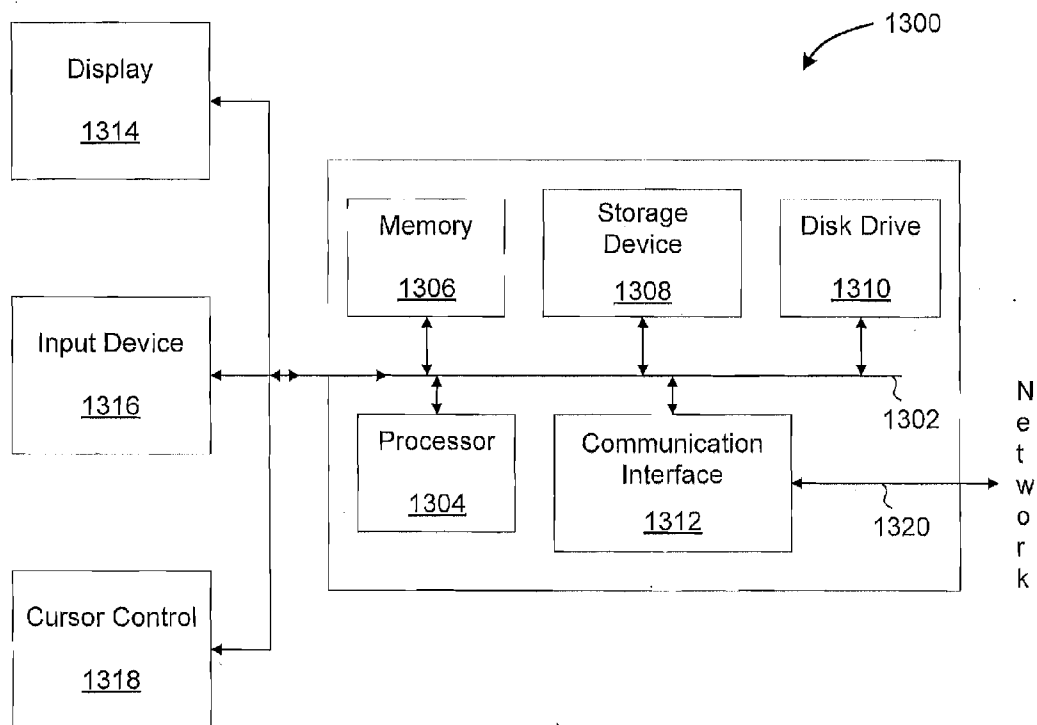

FIG. 13

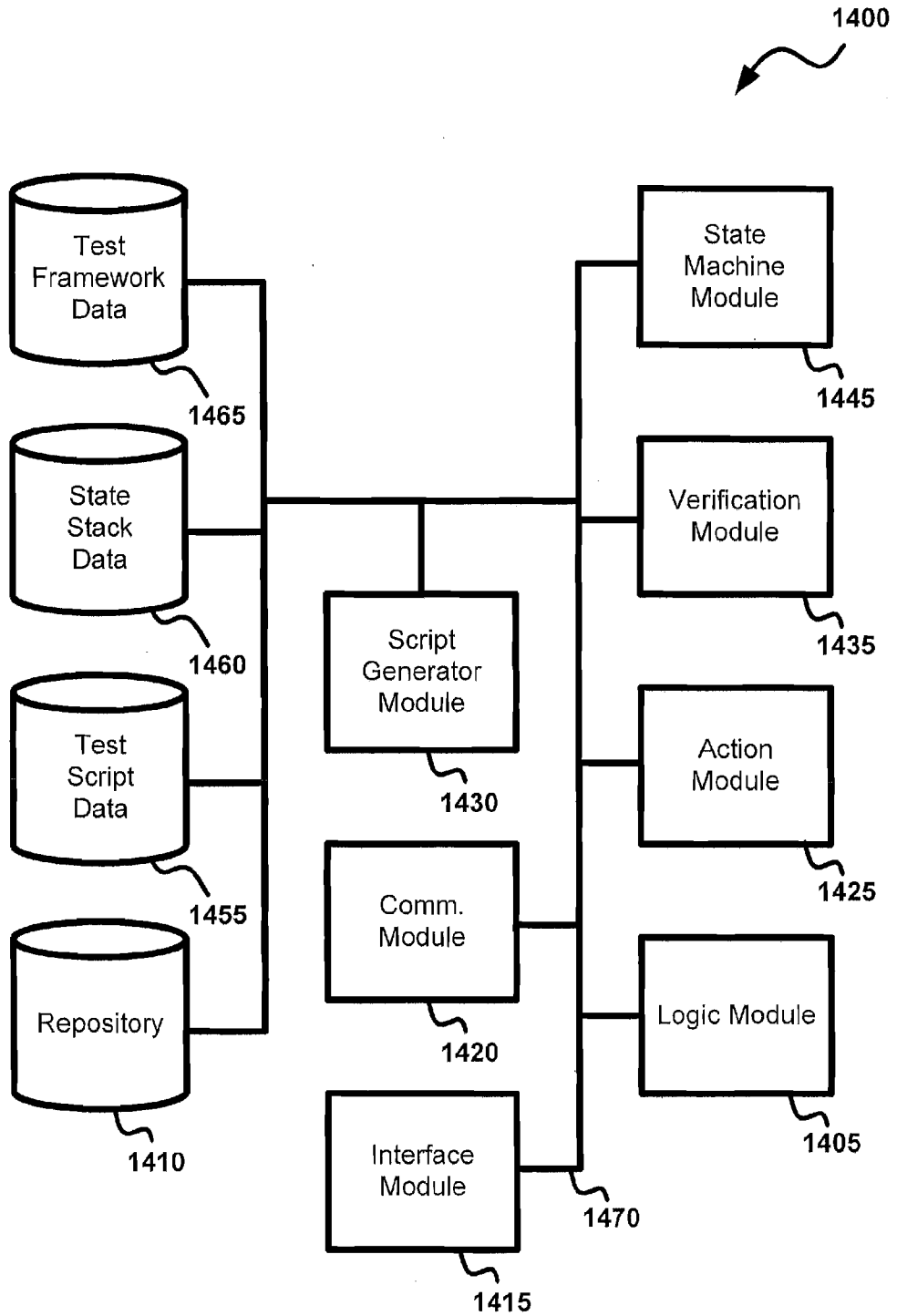

FIG. 14

ARCHITECTURE FOR STATE DRIVEN TESTING

CROSS-REFERENCE TO RELATED APPLICATIONS

[0001] This application is a continuation of prior application Ser. No. 12/861,794, filed Aug. 23, 2010, and entitled "State Driven Testing," and a continuation of application Ser. No. 12/861,801, filed Aug. 23, 2010, and entitled "State Driven Test Editor," both of which are hereby incorporated by reference in its entirety for all purposes.

FIELD

[0002] The present invention relates generally to software, More specifically, the present invention relates to automated testing.

BACKGROUND

[0003] Testing is a critical component in the development of software. Testing is the process of validating and verifying that a software program, application, or product meets the business and technical requirements that guided its design and development, works as expected, and can be implemented with the same characteristics.

[0004] Some software development tools help automate testing by recording tests that are run, allowing "playback" of the test routines. However, an entire test routine is rarely, if ever, applicable to more than one release of one application. Data-driven testing adds some modularity by keeping test input and output values separate from the test procedure, but the procedure itself is still in a single script. Keyword-driven testing breaks the test procedure into logical components that can then be used repeatedly in the assembly of new test scripts. Keyword driven testing separated much of the programming work of test automation from the actual test design, allowing tests to be developed earlier and making the tests easier to maintain.

[0005] Tools such as keyword driven testing allows such business analysts earlier in the testing process. Every software product has a target audience. For example, the audience for video game software is completely different from banking software. An organization's business analysts may have a deep understanding of the target audience, but very little programming knowledge.

[0006] Keyword driven testing is useful, but applications can easily require thousands of automation keywords to be developed and used. Navigating, constructing and maintaining test scripts based on thousands of keywords are cumbersome.

[0007] Computer scientists attempt to keep track of the behavior of systems through tools such as state diagrams. However, state diagrams require the creation of distinct nodes for every valid combination of parameters that define the state, leading to a very large number of nodes and transitions between nodes for all but the simplest of systems (the "state and transition explosion problem"). While UML state diagrams and Harel state charts try to solve the state and transition explosion problem by providing complex formalisms like hierarchical nested states, orthogonal regions, entry and exit actions, and internal transitions, their complexity is inappropriate for the problem of modeling test script navigation for graphical user interface ("GUI") applications. Even with advanced state diagrams and state charts, it remains cumbersome

to understand the interrelationship as well as to maintain changes in the framework from both a structuring as well as a navigation aspect.

[0008] There are continuing efforts to improve automated testing.

BRIEF DESCRIPTION OF THE DRAWINGS

[0009] The present invention will be readily understood by the following detailed description in conjunction with the accompanying drawings. Like reference numerals designate like structural elements, Although the drawings depict various examples of the invention, the invention is not limited by the depicted examples. Furthermore, the depictions are not necessarily to scale.

[0010] FIG. 1 illustrates an exemplary test script editor that creates test scripts;

[0011] FIG. 2 illustrates a diagram 200 of the various components of a state driven testing system and their relationships to each other;

[0012] FIG. 3 illustrates an exemplary algorithm for calculating the application state using Java-like pseudo-code for determining which test objects are accessible when appending an action at the end of a sequence of actions;

[0013] FIG. 4A is an exemplary application state stack with low level state stack methods;

[0014] FIGS. 4B through 4F illustrate an exemplary application state stack after some navigation has occurred and certain sequence of actions are taken;

[0015] FIG. 5 illustrates an exemplary flowchart for determining which test objects are accessible when inserting an action within a sequence of actions;

[0016] FIG. 6 illustrates an exemplary flowchart for determining whether an action or a consecutive sequence of actions can be deleted from a test script without breaking state transitions;

[0017] FIGS. 7A through 7F illustrate an various user interface screens of an exemplary system under test after a certain sequence of actions are taken;

[0018] FIG. 8 illustrates a state diagram for navigating the state transitions for the exemplary application described in FIGS. 7A-7F;

[0019] FIG. 9A through 9H illustrate the exemplary test script editor of FIG. 1 creating a test script for the exemplary application described in FIGS. 7A-7F and 8;

[0020] FIG. 10 illustrates the exemplary test script editor of FIG. 1 when steps four through seven are selected;

[0021] FIG. 11 illustrates the exemplary test script editor of FIG. 1 when steps four through six are selected;

[0022] FIG. 12A through 12E illustrate exemplary notations for a test framework using the exemplary system under test of FIGS. 7A-7F;

[0023] FIG. 13 illustrates an exemplary computer system suitable for testing software; and

[0024] FIG. 14 illustrates an exemplary platform for generating test scripts.

DETAILED DESCRIPTION

[0025] Various embodiments or examples may be implemented in numerous ways, including as a system, a process, an apparatus, a user interface, or a series of program instructions on a computer readable medium such as a computer readable storage medium or a computer network where the program instructions are sent over optical, electronic, or wire-

less communication links. In general, operations of disclosed processes may be performed in an arbitrary order, unless otherwise provided in the claims.

[0026] A detailed description of one or more examples is provided below along with accompanying figures. The detailed description is provided in connection with such examples, but is not limited to any particular example. In other examples, the described techniques may be varied in design, architecture, code structure, or other aspects and are not limited to any of the examples provided. The scope is limited only by the claims and numerous alternatives, modifications, and equivalents are encompassed. Numerous specific details are set forth in the following description in order to provide a thorough understanding. These details are provided for the purpose of example and the described techniques may be practiced according to the claims without some or all of these specific details. For clarity, technical material that is known in the technical fields related to the examples has not been described in detail to avoid unnecessarily obscuring the description.

[0027] State driven testing identifies state transitions of user interface (“UI”) objects such that the set of allowed UI actions (e.g., keywords) at a specific point in a test script can be minimized. Instead of presenting the tester with all available keywords, only those keywords available at a specific point in navigation are accessible to the user. The limited keywords allows for the rapid development and maintenance of test cases through tools such as a test case editor.

[0028] FIG. 1 illustrates an exemplary test script editor **100** that creates and modifies test scripts. The test script editor **100** enables the building of maintainable and stable test scripts by selecting from a set of accessible actions **110**. Actions **110** are a combination of test objects **120** and test methods **130**. The availability of any action (e.g., available test objects **140**) is based on the specific point in navigation. The test script editor **100** may also further provide context sensitive navigation help **150** for appending steps at the end of the script, inserting steps within the script, changing existing steps and deleting steps.

[0029] A test method **130** represents an action against the system under test (“SUT”) like entering data, verifying response data and navigating in the application. A test object **120** is typically used to structure the test framework so that all available actions are represented for a specific UI container of the SUT (e.g., dialog, tree-view, data-grid, pane, frame, or menu).

[0030] FIG. 2 illustrates a diagram **200** of the various components of a state driven testing system and their relationships to each other. The diagram **200** indicates the interactions between the test script **210**, the application state engine **220**, the application state stack **230**, the test framework **240**, and the available actions **250**. The test script **210** is the sequence of test steps or actions to be taken against the SUT.

[0031] Accessible actions are calculated by the state engine **220**, which calculates all state transitions of preceding actions and, preferably, subsequent actions in the script. The state engine **210** can preferably determine (A) which test objects are accessible when appending an action at the end of a sequence of actions, (B) which test objects and test methods are accessible when inserting an action within a sequence of actions, (C) which test objects and test methods can be changed for an existing test script step while maintaining the integrity of the test script, i.e., without breaking state transitions for succeeding actions, and (D) which consecutive

sequence of actions can be deleted from a sequence of actions without breaking state transitions. A broken state transition causes actions that are not reachable through the state transitions of the predecessor actions and violates the integrity of the test script.

[0032] The application state stack **230** allows application states to be easily re-established to former application states by providing a mechanism to maintain multiple application states (e.g., a last in, first out (LIFO) stack). An application state stack **230** is useful, among other things, in scenarios where a former application state needs to be preserved. A modal dialog is one example of when it would be desirable to preserve the application state and introduce a new application state that only covers actions available inside the modal dialog. In user interface design, a modal dialog is a child window that requires users to interact with it before they can return to operating the parent application thus preventing the workflow on the application main window (e.g., age verification, password entry, file name selection). After closing the modal dialog it is usually desirable to re-establish the application state of the application that existed before opening the modal dialog.

[0033] In computer science the behavior of a system is a function of (a) the execution instructions, (b) the input and (c) the current state. A state is traditionally defined as a unique configuration of information in a program or machine. For a SUT, the application state can be defined by the sequence of all prior state transitions and can be represented by the list of available test objects **140** that are accessible at a specific position in the test script **210**. A state transition can be associated with a test method **130** and defines the accessible test objects **140** after executing the test method **130**. Multiple state transition methods can be used to change the application state. Additionally, if the accessible test objects **140** of a test method **130** (the test method’s state transition) is the same as the current state, then no change in application state will occur.

[0034] The test framework **240** represents the collection of all test objects **120** and associated test methods **130** (shown in FIG. 1) including the state transitions, which describes all possible navigation in the SUT.

[0035] FIG. 3 illustrates an exemplary algorithm **300** using Java-like pseudo-code for determining which test objects are accessible at a certain position of the test script. State transition methods such as RestoreAppState **310**, SetAppState **320**, AddAppState **330**, RemoveAppState **340** and NewAppState **350**, are indicated as being used to change the application state stack. NewAppState **350** is described in connection with FIG. 4B, RestoreAppState **310** is described in connection with FIG. 4C, SetAppState **320** is described in connection with FIG. 4D, AddAppState **330** is described in connection with FIG. 4E and RemoveAppState **340** is described in connection with FIG. 4F.

[0036] FIG. 4A illustrates an exemplary application state stack **400** with low level state stack methods (“push” and “pop”). An application state **410**, **420**, **430** represents the set of test objects that are accessible at a specific position in the test script. The application start state **410** is a special application state represented by the set of test objects that are used to describe the user’s first possible interactions. Any given application state is defined by the sequence of state transitions defined for preceding test script lines (actions) starting from the application start state **410**, including the current application state **430**, and all intermediate application states **420**. The

“New state” box **433** with the basic stack function “Push” is used to illustrate how to add a new state at the top of the state stack (=current state). The “TO1, TO2, TO3” box **436** with the basic stack function “Pop” is used to illustrate how to remove the current state from the state stack.

[0037] The exemplary application state stack **400** can be acted upon by the state engine **220** using the algorithm **300**. FIG. 4B illustrates the exemplary application state stack **440** after the NewAppState **350** transition method with an input of TO4 is applied. The transition method NewAppState **350** saves the current application state **430** on the application state stack **440** and sets the current state to the newly created state **450**. In other words, the first set of states (TO1, TO2, TO3) ceases being the current state and the second set of states (TO4) becomes the new current state.

[0038] FIG. 4C illustrates the exemplary application state stack **460** after the RestoreAppState **310** transition method is applied. The transition method RestoreAppState **310** removes the existing application state **450** from the application state stack **440**, resulting in an application state stack **460** identical to the application state stack **400** prior to the NewAppState **350** transition method being applied.

[0039] FIG. 4D illustrates the exemplary application state stack **470** after the SetAppState **320** transition method with an input of TO4 is applied. The transition method SetAppState **320** sets the current application state **475** to the list of test objects provided as input, removing former test objects of the prior current state **430**.

[0040] FIG. 4E illustrates the exemplary application state stack **480** after the AddAppState **330** transition method with an input of TO1 and TO3 is applied. The transition method AddAppState **330** adds the list of test objects provided as input to the current application state **485** while retaining the set of test objects of the former state **475**.

[0041] FIG. 4F illustrates the exemplary application state stack **490** after the RemoveAppState **340** transition method with an input of TO4 is applied. The transition method RemoveAppState **340** removes from the former state **485** the list of test objects provided as input from the current application state **495**.

[0042] FIG. 5 illustrates an exemplary flowchart **500** for determining which test objects are accessible when inserting an action within a sequence of actions. The exemplary algorithm **500** assumes a five step test script **210** with an action inserted after the second step. The output of the exemplary flowchart **500** is a test script describing the structure of accessible test objects and test methods.

[0043] In block **510** all accessible test objects after the insertion point (i.e., step **2**) are retrieved. In a preferred embodiment, algorithm **300** may be used for block **510**. In block **520**, the state stack prior to the insertion point is saved. Block **530** then begins the decision tree that occurs for each of the returned test objects. In block **530** the state transition for the test object and test method under analysis is added to the saved stack. In block **540** a check is made whether the subsequent steps (i.e., steps three through five) are still reachable through state transitions when using the current state stack. Subsequent steps are reachable if the test object of the step is part of the accessible test objects for the application state. If the subsequent steps are reachable, then in block **550** the test object and test method is added to the structure of accessible test objects and methods. In block **560** the saved stack is then restored. Block **570** ensures the process is repeated for each test method of the current test object. Similarly, block **580**

ensures the process is repeated for each test object. Block **590** returns the structure of accessible test objects and test methods, completing the algorithm **500**.

[0044] The algorithm of FIG. 5 can similarly be used to determine which test objects are accessible when changing an action within a sequence of actions. Assuming the step to be modified is the third step of the test script **210**, the same algorithm can be used except that in block **540** the subsequent steps that need to be checked for reachability are only steps four and five since step three is the step being changed.

[0045] FIG. 6 illustrates an exemplary flowchart **600** for determining whether an action or a consecutive sequence of actions can be deleted from a test script **210** without breaking state transitions. The exemplary algorithm **600** assumes the deleted action(s) start with step **3**. The output of the exemplary flowchart **600** is a test script describing the structure of accessible test objects and test methods.

[0046] In block **610** the state engine **220** calculates the state for the steps preceding the deletion point (i.e., steps one and two). In block **620** the state stack prior to the deletion point is saved. Block **620** may have an implementation that is similar to block **520** in FIG. 5. In step **630** a check is made whether steps subsequent to the deleted steps are still reachable through state transitions when using the current state stack. For example, if steps three and four are being deleted, and the test script **210** is only five steps long, then only step five needs to be checked for reachability. In block **640** the accessible test objects and test methods are returned. Block **640** may have an implementation that is similar to block **590** in FIG. 5. If no subsequent steps are reachable, then only the saved state stack (i.e., steps one and two) would be returned.

[0047] As described herein, state transitions are associated with test methods and define how the accessible test objects potentially change after executing the test method. However, in an alternative approach of application state management state transitions can be defined through changes of accessible test methods instead of changes of accessible test objects. This alternative approach, however, may become cumbersome for a SUT that offers hundreds to thousands test methods. By defining a state transition on the test object level, state management loses some accuracy by not exactly defining which test methods of a test object are accessible, but gains practicability as users only need to define which test objects are accessible after executing a test method.

[0048] FIG. 7A illustrates an application login dialog **700** for an exemplary application that is to be tested with state driven testing. After starting the exemplary application the login dialog is the first choice presented to the user. Pressing the Cancel button **702** will exit the application. Specifying “User”, “Password”, and pressing the OK button **704** will bring up the main window of the application.

[0049] FIG. 7B illustrates the main window **710** for the exemplary application under test after logging in. In the main window, pressing the A button **712** opens the grid pane displaying order data (“A-Grid”). Pressing the B button **714** opens the grid pane displaying order item data (“B-Grid”). Pressing the Logout button **716** logs the user out and displays the login dialog **700**.

[0050] FIG. 7C illustrates the main window **710** for the exemplary application under test after the A button **712** was pressed. Pressing the A button **712** opened up a grid pane **724** with three columns and also displayed the New button **718**,

the Edit button **720** and the Delete button **722**. The Edit button **720** and the Delete button **722** are disabled as long as no row is selected.

[0051] FIG. 7D illustrates the main window **710** for the exemplary application under test after a row **726** in the grid pane **724** was selected. The Edit button **720** and the Delete button **722** are enabled as a result of selecting the row **726**.

[0052] FIG. 7E illustrates a modal dialog **730** that was created as a result of pressing the Edit button **720**. Pressing the OK button **732** saves the changes and goes back to the grid pane for A. Pressing the Go to B button **734** saves the changes and goes to the grid for B.

[0053] FIG. 7F illustrates the main window **710** for the exemplary application under test displaying a grid pane **736** with B-Grid data.

[0054] FIG. 8 illustrates an improved state diagram **800** for navigating the state transitions for the exemplary application described in FIGS. 7A-7F. Six application states **810**, **820**, **830**, **840**, **850** and **860** are depicted and each is described by the test objects available at that point in the navigation of the SUT. Each application state has an associated set of test objects with its test methods **815**, **825**, **835**, **845**, **855**, **865** that are accessible for that state. The application states and their associated test objects are described in detail below.

[0055] FIG. 9A illustrates the exemplary test script editor **100** starting a test script for the exemplary application described in FIGS. 7A-7F and 8. When working with the test framework for the exemplary application the first available test object is the Start object **905**. Within the Start object **905** the user can choose from the available test methods **815** selectOk, selectCancel, and setUsernameAndPassword. The application state is described in the improved state diagram **800** in FIG. 8 with the Start state **810**.

[0056] FIG. 9B illustrates the exemplary test script editor **100** after the action Start.setUsernameAndPassword is completed. The state transition associated with the test method setUsernameAndPassword is the Start state **810**. Since the application state was already in the Start state **810** no state change occurred. The same set of test objects and test methods that was accessible for step one is also accessible for step two. Accordingly, a test method's "state transition" does not always result in a changed state; it merely identifies the state of the application after the test method is executed.

[0057] FIG. 9C illustrates the exemplary test script editor **100** after the action Start.selectOK is completed, which caused the application state to change and made the Main object **910** accessible. Within the Main object **910** the user can choose from available test methods **825** selectA, selectB, and selectLogout. The application state is described in the improved state diagram **800** in FIG. 8 with the Main state **820**.

[0058] FIG. 9D illustrates the exemplary test script editor **100** after the action Main.selectA is completed, which caused the application state to change and made both the AGrid object **915** and the Main object **910** available for step four. Together, the two objects **910** and **915** represent the application state, and are described in the improved state diagram **800** in FIG. 8 with the AGrid, Main state **830**. Although FIG. 8 does not distinguish between the two test objects, the available test methods **835** are associated with the specific test object. Accordingly, within the Main object **910** the user can choose from available test methods selectA, selectB, and selectLogout and within the AGrid object **915** the user can choose from available test method selectRow.

[0059] FIG. 9E illustrates the exemplary test script editor **100** after the action AGrid.selectRow is completed, which caused the application state to change and made the AAction object **920**, the AGrid object **915** and the Main object **910** available for step five. Together, the three objects represent the application state, and are described in the improved state diagram **800** in FIG. 8 with the AAction, AGrid, Main state **840**. As previously described, only certain test methods are available in connection with certain test objects. As before, within the Main object **910** the user can choose from available test methods selectA, selectB, and selectLogout and within the AGrid object the user can choose from available test method selectRow. The new test object AAction also allows the user to choose from available test method selectEdit.

[0060] FIG. 9F illustrates the exemplary test script editor **100** after the action AAction.selectEdit is completed, which caused the application state to change and made the AEditDialog object **925** accessible for step six. Within the AEditDialog object **925** the user can choose from available test methods **855** selectCancel, selectOK, selectOkAndGotoB, setColumn1, setColumn2 and setColumn3. The application state is described in the improved state diagram **800** in FIG. 8 with the Main state **850**.

[0061] FIG. 9G illustrates the exemplary test script editor **100** after the action AEditDialog.setColumn1 is completed. Since no state change occurred, the same set of test objects and test methods that was accessible for step six is also accessible for step seven.

[0062] FIG. 9H illustrates the exemplary test script editor **100** after the action AEditDialog.selectOkAndGotoB is completed, which caused the application state to change and made both the BGrid object **930** and the Main object **910** available for step eight. The application state is described in the improved state diagram **800** in FIG. 8 with the BGrid, Main state **860**.

[0063] FIG. 10 illustrates the exemplary test script editor **100** when steps four through seven are selected. Since the delete button **1005** is enabled, the test object in step eight ("Main") is reachable through state transitions of steps one, two, three and eight. In other words, step eight can be integrated with step three.

[0064] FIG. 11 illustrates the exemplary test script editor **100** when steps four through six are selected. Since the delete button **1005** is disabled, the test object in a step subsequent to step six (in this case, step seven, "AEditDialog") is not reachable. A modified test script of steps one, two, three, and seven has lost its integrity and step seven cannot be integrated with step three.

[0065] FIG. 12A illustrates an exemplary notation **1200** using a Domain Specific Language for indicating the test framework using a state stack for state transitions. StartObject **1210** defines the test object(s) which are available after starting the application. StateTransition **1220** defines the state transitions for a test method. Multiple calls to state transitions methods (e.g., AddAppState, NewAppState, SetAppState, RestoreAppState, RemoveAppState) can be listed to define a state transition. The state transition for the test method selectOkAndGotoB **1230** removes the current application state from the stack to express that the modal dialog **730** ("AEditDialog") is closed and sets the current application state to the previous state. It also removes the test objects AAction and AGrid from the new current state to express that the A-Grid and its actions are not available and adds the test object BGrid to the current application state to express that the B-Grid is

now accessible. Alternatively the following (simpler) state transition can be used to express the same state transition: StateTransition: RestoreAppState, SetAppState(BGrid). In one embodiment, specifying more than one state transition for a test method will not cause those state transitions to be executed in the order specified, but instead in the following order: (1) RestoreAppState, (2) SetAppState, (3) AddAppState, (4) RemoveAppState, and (5) NewAppState.

[0066] FIG. 12B illustrates an exemplary test framework 1240 using a state stack for state transitions using an inline definition of state transitions using Java annotations.

[0067] FIG. 12C illustrates an exemplary test framework 1250 using a state stack for state transitions using an inline definition of state transitions using Net attributes.

[0068] FIGS. 12D and 12E illustrate an exemplary test framework 1260 and 1261 using a state stack for state transitions using an external definition of a state transition model through XML. By using an external XML notion with references to the implementation of test methods the test framework 1260 and 1261 can be easily applied to test frameworks written in programming languages that provides an external call-level interface (e.g., C-DLLs, COM interface, .NET assembly, Java class file).

[0069] Those skilled in the art will appreciate that by providing a state transition model that uses a state stack to define and maintain state transitions as part of the actions (expressed through test objects and test methods) of the system solves the problem of state and transition explosion in a very effective and simple way.

[0070] In some examples, the described techniques may be implemented as a computer program or application (“application”) or as a plug-in, module, or sub-component of another application. The described techniques may be implemented as software, hardware, firmware, circuitry, or a combination thereof. If implemented as software, the described techniques may be implemented using various types of programming, development, scripting, or formatting languages, frameworks, syntax, applications, protocols, objects, schema, or techniques, including, but not limited to, VB, C, Objective C, C++, C#, Java™, Javascript™, COBOL, XML, MXML, PHP, and others. The described techniques may be varied and are not limited to the examples or descriptions provided.

[0071] FIG. 13 illustrates an exemplary computer system suitable for disk storage performance using digital memory and data compression. In some examples, computer system 1300 may be used to implement computer programs, applications, methods, processes, or other software to perform the above-described techniques. Computer system 1300 includes a bus 1302 or other communication mechanism for communicating information, which interconnects subsystems and devices, such as processor 1304, system memory 1306 (e.g., RAM), storage device 1308 (e.g., ROM), disk drive 1310 (e.g., magnetic or optical), communication interface 1312 (e.g., modem or Ethernet card), display 1314 (e.g., CRT or LCD), input device 1316 (e.g., keyboard), and cursor control 1318 (e.g., mouse or trackball).

[0072] According to some examples, computer system 1300 performs specific operations by processor 1304 (which may include a plurality of processors) executing one or more sequences of one or more instructions stored in system memory 1306. Such instructions may be read into system memory 1306 from another computer readable medium, such as static storage device 1308 or disk drive 1310. In some

examples, hard-wired circuitry may be used in place of or in combination with software instructions for implementation.

[0073] The term “computer readable medium” refers to any tangible medium that participates in providing instructions to processor 1304 for execution. Such a medium may take many forms, including but not limited to, non-volatile media and volatile media. Non-volatile media includes, for example, optical or magnetic disks, such as disk drive 1310. Volatile media includes dynamic memory, such as system memory 1306. In some examples, a single apparatus (i.e., device, machine, system, or the like) may include both flash and hard disk-based storage facilities (e.g., solid state drives (SSD), hard disk drives (HDD), or others). In other examples, multiple, disparate (i.e., separate) storage facilities in different apparatus may be used. Further, the techniques described herein may be used with any type of digital memory without limitation or restriction. The described techniques may be varied and are not limited to the examples or descriptions provided.

[0074] Common forms of computer readable media includes, for example, floppy disk, flexible disk, hard disk, magnetic tape, any other magnetic medium, CD-ROM, any other optical medium, punch cards, paper tape, any other physical medium with patterns of holes, RAM, PROM, EPROM, FLASH-EPROM, any other memory chip or cartridge, or any other medium from which a computer can read.

[0075] Instructions may further be transmitted or received using a transmission medium. The term “transmission medium” may include any tangible or intangible medium that is capable of storing, encoding or carrying instructions for execution by the machine, and includes digital or analog communications signals or other intangible medium to facilitate communication of such instructions. Transmission media includes coaxial cables, copper wire, and fiber optics, including wires that comprise bus 1302 for transmitting a computer data signal.

[0076] In some examples, execution of the sequences of instructions may be performed by a single computer system 1300. According to some examples, two or more computer systems 1300 coupled by communication link 1320 (e.g., LAN, PSTN, or wireless network) may perform the sequence of instructions in coordination with one another. Computer system 1300 may transmit and receive messages, data, and instructions, including program, i.e., application code, through communication link 1320 and communication interface 1312. Received program code may be executed by processor 1304 as it is received, and/or stored in disk drive 1310, or other non-volatile storage for later execution.

[0077] FIG. 14 illustrates an exemplary platform 1400 for generating test scripts. Platform 1400 includes logic module 1405, repository 1410, interface module 1415, communications module 1420, action module 1425, script generator module 1430, verification module 1435, state machine module 1445, test script data 1455, state stack data 1460, test framework data 1465, and bus 1470. Platform 1400 illustrates a block modular architecture of an application configured to perform the described techniques. Logic module 1405 may be implemented as logic configured to generate control signals to repository 1410, interface module 1415, communications module 1420, action module 1425, script generator module 1430, verification module 1435, state machine module 1445, test script data 1455, state stack data 1460, test framework data 1465, and bus 1470. Logic module 1405 may be implemented as a module, function, subroutine, function set, rule

set, or other type of software, hardware, circuitry, or combination that enables control of application **1400** and the described elements.

[0078] As shown, repository **1410** may be implemented as a single, multiple-instance, standalone, distributed, or other type of data storage facility, similar to those described above in connection with FIG. **13**. In other examples, repository **1410** may also be implemented partially or completely as a local storage facility for data operated upon by platform **1400** and the described elements. In other examples, repository **1410** may be a remote data storage facility that is used to provide storage for platform **1400**. Still further, some or all of repository **1410** may be used to provide a cache or queue for one or more of the elements shown for platform **1400**. Although test framework data **1465**, state stack data **1460**, and test script data **1455** are depicted for ease of understanding as separate from repository **1410**, they may all be part of the same data storage facility.

[0079] Interface module **1415** may be implemented to utilize input/output devices. In some examples, an input may be a graphical, visual, or iconic representation displayed on a computer screen that, when selected using an input/output device (e.g., mouse, keyboard, or others) indicates an item (e.g., data structure (e.g., table, record, file, queue, or others), function (e.g., pull down menu, pop-up window, or others), feature (e.g., radio button, text box, form, or others)) or type of item that should be included in an application. FIGS. **9-11** are an example of screens that interface module **1415** can displayed to a user.

[0080] In some examples, communications module **1420** may be configured to send and receive data from platform **1400**. For example, platform **1400** may be implemented on one or more remote servers and, when a message (e.g., data packet) is received from a remote client over a data network (e.g., network of FIG. **13**), communications module **1420** receives, decodes, or otherwise interprets data from the message and transmits the data over bus **1470**. Some implementations may have the actual testing of the SUT be performed remotely and the communications module **1420** ensures the final test script is sent to the remote server testing the SUT. In such an implementation, the business analysts responsible for using the platform **1400** and performing the navigations that generate the test scripts may be segregated from the actual coders responsible for the SUT.

[0081] In one embodiment, action module **1425** analyzes data from the test framework data **1465**, the state stack data **1460**, and a user's input from the interface module **1415** in order to determine which test methods are accessible from a selected test objects in the current state. State stack data **1460** keeps track of the current state and is modified as the application is used. Test framework data **1465** represents the collection of all test objects, test methods, and state transitions, including their various relationships. For example, each test method is associated with a single test object. Similarly, in one embodiment, each test method is associated with a potential state transition (whether a test method results in an actual state transition depends on the current state of the SUT). If the current state has multiple test objects, then in one embodiment the user must select one test object in order to view the accessible test methods for the selected test object. Test framework data **1465** can be created individually or collaboratively by coders of the SUT and business analysts.

[0082] The verification module **1435** uses the state machine module **1445** to test modifications proposed by a user through

the interface module **1415** and ensures the user is not proposing a broken state transition where one state is not reachable through prior test object/test method choices. The verification module **1435** can also work with the action module **1425** to: propose test objects and test methods when an action is to be inserted within the test script, identify test objects and test methods that can be altered, and identify actions that can be deleted. The verification module **1435** ensures that script integrity is maintained for any modifications to the test script.

[0083] Script generator module **1430** updates the test script from the test script data **1455** and a user's navigation, received as inputs from the interface module **1415**. The test script is output to the test script data **1455**.

[0084] State machine module **1445** additionally uses the state stack data **1460** and inputs from either the verification module **1435** or the interface module **1415** to update the state stack data **1460**.

[0085] Although the foregoing examples have been described in some detail for purposes of clarity of understanding, the invention is not limited to the details provided. There are many alternative ways of implementing the invention. The disclosed examples are illustrative and not restrictive.

What is claimed:

1. A system comprising:

a memory configured to store application states, test objects, test methods, and their relationships;

an action module configured to generate a subset of accessible test methods from a test object selection, the subset being determined by the relationship between the test methods, the test objects and the application states; and
a script generator module configured to generate a test script in response to a test method selection from the subset of accessible test methods.

2. The system of claim 1, further comprising:

a state machine module configured to modify an application state stack in response to the selection of test methods,

wherein the memory is further configured to maintain an application state stack.

3. The system of claim 1, wherein each state in the state stack includes accessible test objects.

4. The system of claim 2, wherein each test method is associated with state whereby a test method selection results in a potential state transition.

5. The system of claim 1, further comprising an interface module that is configured to receive the test method selection,

6. The system of claim 1, further comprising a verification module that is configured to ensure script integrity is maintained for any modifications to the test script.

7. The system of claim 6, wherein the modifications to the test script can include appending an action to the end of the test script, inserting an action within the test script, deleting an action from the test script and altering an action within the test script.

8. A system comprising:

a memory configured to store application states, test objects and test methods and their relationships; and

a verification module that is configured to check the integrity of a modification to the test script, the integrity being determined by the relationship between the test methods, the test objects and the application states; and

a script generator module configured to generate a test scripts.

9. The system of claim **8**, further comprising:
a state machine module configured to modify an application state stack in response to a selection of a test method,
wherein the memory is further configured to maintain an application state stack.

10. The system of claim **9**, wherein each state in the state stack includes accessible test objects.

11. The system of claim **9**, wherein each test method is associated with state whereby a test method selection results in a potential state transition.

12. The system of claim **8**, further comprising an interface module that is configured to receive the test method selection.

13. The system of claim **8**, wherein the modifications to the test script can include appending an action to the end of the test script, inserting an action within the test script, deleting an action from the test script and altering an action within the test script.

14. A system comprising:
a memory configured to store application states, a state stack, test objects and test methods, wherein the application state includes a first set of test objects, the test methods can be associated with one or more state transitions, and each test method is associated with one test object;
a state machine module configured to modify an application state stack in response to a selection of a test method;
a verification module that is configured to check the integrity of a modification to the test script, the integrity being determined by the relationship between the test methods, the test objects and the application states; and
a script generator module configured to generate a test scripts.

15. The system of claim **14**, further comprising an action module configured to generate a subset of accessible test methods from a test object selection.

* * * * *