

(12) STANDARD PATENT
(19) AUSTRALIAN PATENT OFFICE

(11) Application No. **AU 2009265578 B2**

(54) Title
Method for manufacturing a cooling element and a cooling element

(51) International Patent Classification(s)
F27B 1/24 (2006.01) **F27D 1/12** (2006.01)
C21B 7/10 (2006.01)

(21) Application No: **2009265578** (22) Date of Filing: **2009.06.30**

(87) WIPO No: **WO10/000939**

(30) Priority Data

(31) Number	(32) Date	(33) Country
20085669	2008.06.30	FI

(43) Publication Date: **2010.01.07**

(44) Accepted Journal Date: **2015.10.01**

(71) Applicant(s)
Outotec Oyj

(72) Inventor(s)
Jafs, Mikael;Hugg, Eero;Saarinen, Risto

(74) Agent / Attorney
Griffith Hack, GPO Box 1285, Melbourne, VIC, 3001

(56) Related Art
JP 2000-256715 A
WO 2004/011866 A1



- (51) **International Patent Classification:**
F27B 1/24 (2006.01) *C21B 7/10* (2006.01)
F27D 1/12 (2006.01)
- (21) **International Application Number:**
PCT/FI2009/050592
- (22) **International Filing Date:**
30 June 2009 (30.06.2009)
- (25) **Filing Language:** Finnish
- (26) **Publication Language:** English
- (30) **Priority Data:**
20085669 30 June 2008 (30.06.2008) FI
- (71) **Applicants (for all designated States except US):** **OUT-OTEC OYJ** [FI/FI]; Riihitontuntie 7 E, FI-02200 Espoo (FI). **SAARINEN, Risto** [FI/FI]; Niittykuja 2 A 25, FI-02200 Espoo (FI).
- (72) **Inventors; and**
- (75) **Inventors/Applicants (for US only):** **HUGG, Eero** [FI/FI]; Kuukausikuja 4 as 19, FI-02200 Espoo (FI). **JÄFS, Mikael** [FI/FI]; Kasavuorentie 12 C 11, FI-02700 Kauniainen (FI).
- (74) **Agent:** **BORENIUS & CO OY AB**; Tallberginkatu 2 A, FI-00180 Helsinki (FI).
- (81) **Designated States (unless otherwise indicated, for every kind of national protection available):** AE, AG, AL, AM, AO, AT, AU, AZ, BA, BB, BG, BH, BR, BW, BY, BZ, CA, CH, CL, CN, CO, CR, CU, CZ, DE, DK, DM, DO, DZ, EC, EE, EG, ES, FI, GB, GD, GE, GH, GM, GT, HN, HR, HU, ID, IL, IN, IS, JP, KE, KG, KM, KN, KP, KR, KZ, LA, LC, LK, LR, LS, LT, LU, LY, MA, MD, ME, MG, MK, MN, MW, MX, MY, MZ, NA, NG, NI, NO, NZ, OM, PE, PG, PH, PL, PT, RO, RS, RU, SC, SD, SE, SG, SK, SL, SM, ST, SV, SY, TJ, TM, TN, TR, TT, TZ, UA, UG, US, UZ, VC, VN, ZA, ZM, ZW.
- (84) **Designated States (unless otherwise indicated, for every kind of regional protection available):** ARIPO (BW, GH, GM, KE, LS, MW, MZ, NA, SD, SL, SZ, TZ, UG, ZM, ZW), Eurasian (AM, AZ, BY, KG, KZ, MD, RU, TJ, TM), European (AT, BE, BG, CH, CY, CZ, DE, DK, EE, ES, FI, FR, GB, GR, HR, HU, IE, IS, IT, LT, LU, LV, MC, MK, MT, NL, NO, PL, PT, RO, SE, SI, SK, TR), OAPI (BF, BJ, CF, CG, CI, CM, GA, GN, GQ, GW, ML, MR, NE, SN, TD, TG).

Declarations under Rule 4.17:

— of inventorship (Rule 4.17(iv))

Published:

— with international search report (Art. 21(3))

[Continued on next page]

(54) **Title:** METHOD FOR MANUFACTURING A COOLING ELEMENT AND A COOLING ELEMENT

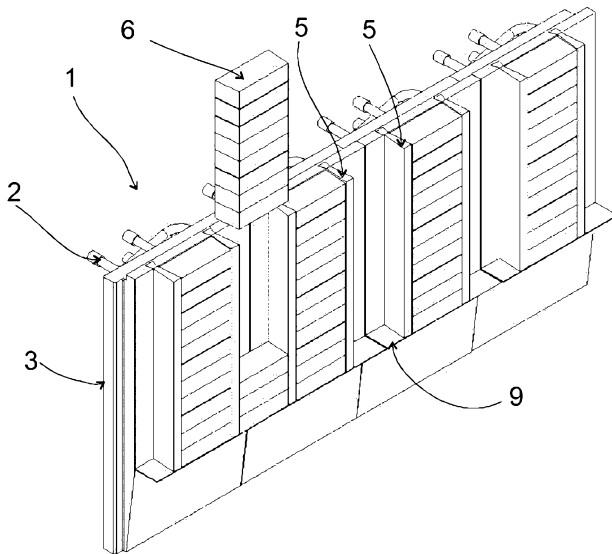

Fig1

(57) **Abstract:** The invention relates to a method for manufacturing a cooling element (1) to be used in connection with a metallurgical furnace or the like. In the method, there is arranged a frame element (3) mainly made of copper and provided with water cooling channels (2); in the frame element (3), there are arranged fastening elements (4) for connecting refractory bricks (6) to the frame element (3); and refractory bricks (6) are connected to the frame element (3) by using fastening elements (4). The fastening elements (4) are at least partly formed of elongate fastening strips made of steel (5). The elongate fastening steel strips (5) are fastened to the frame element (3) so that the elongate fastening steel strips (5) together form in between them an open interspace (7), which is narrowed in a direction pointed away from the bottom (8) of the open interspace (7). Refractory bricks (6) are arranged in the open interspace (7), so that the refractory bricks (6) are located at least partly in the open interspace (7).

The invention also relates to a cooling element (1) to be used in connection with a metallurgical furnace or the like, being mainly made of copper and provided with water cooling channels (2).

WO 2010/000939 A1



- *before the expiration of the time limit for amending the claims and to be republished in the event of receipt of amendments (Rule 48.2(h))*

METHOD FOR MANUFACTURING A COOLING ELEMENT AND A COOLING ELEMENT

Background of invention

5 The invention relates to a method for manufacturing a cooling element used in connection with a metallurgic furnace or the like, in which method there is arranged a frame element, being mainly made of copper and including water cooling channels; the frame element is provided with fastening elements for connecting refractory bricks to the frame element; and refractory bricks are connected to the frame element by using the fastening elements.

10 The invention also relates to a cooling element used in connection with a metallurgic furnace or the like, being mainly made of copper and including water cooling channels, said cooling element comprising a frame element being mainly made of copper and including water cooling channels, refractory bricks and fastening elements for connecting refractory bricks to the frame element.

15 In the prior art there are known various different methods for manufacturing a cooling element comprising a frame element being mainly made of copper and including water cooling channels, and refractory bricks that are fastened to the frame element by fastening elements. This kind of cooling element is fitted for example in a metallurgical furnace so that the brick lining formed of refractory bricks is in contact with molten metal. Together with the metallurgical furnace, the brick linings fitted in the metallurgical furnace form a structure that is in contact with molten metal. The purpose with this kind of cooling element is that part of the thermal energy directed to the brick lining by the molten metal is transferred from the brick lining to the frame element provided with water cooling, and as a consequence, the brick lining is cooled. 20 Therefore, in between the frame element and the brick lining, there should be arranged a thermal contact that is as good as possible.

25 One problem with this kind of cooling elements has, however, conventionally been that in the course of time, in between the refractory bricks and the frame element, there can be created a gap that prevents heat from being transferred from the brick lining to the frame element. This results in that the bricks are not cooled, and as a consequence, they are damaged, which may further result in a situation where the cooling element itself is subjected to a thermal stress so high that the whole cooling element is damaged.

30 From the Finnish patent publication 109937 there is known a composite cooling element that is manufactured by joining the elements of the ceramic lining together by copper casting, and by at the same time arranging at the back of the lining

a copper plate that is provided with cooling water channels. The invention described in said Finnish patent publication 109937 also relates to a composite cooling element manufactured by said method.

From the Finnish patent publication 20002408 there is known a cooling element, particularly designed to be used in connection with producing metals in a flash converting furnace, said cooling element comprising a frame element, which is provided with a channel system for the cooling water circulation, and on the frame element surface on the side of the furnace space, there are made grooves where elements of the furnace lining can be arranged. The frame element is mainly made of copper, and on the frame element surface on the side of the furnace, there are made grooves where elements of the ceramic lining of the furnace can be arranged, and grooves where there are fitted steel elements, so that at least that part of the cooling element surface placed in the area of the border surface between the molten metal and molten slag that may get into contact with the molten metal, is made of steel.

15 **Brief description of invention**

An object of the invention is to realize a method for manufacturing a cooling element used in connection with a metallurgical furnace or the like, by which method there can be manufactured a cooling element that has a particularly good thermal contact between the frame element and the refractory bricks.

Advantageously, the invention provides a cooling element used in connection with a metallurgical furnace or the like, said cooling element being mainly made of copper and provided with water cooling channels, and having a particularly good thermal contact between the frame element and the refractory bricks.

In an embodiment, the present invention provides a method for manufacturing a cooling element to be used in connection with a metallurgical furnace or the like, in which method

- there is arranged a frame element that is mainly made of copper and provided with water cooling channels,

- in the frame element, there are provided fastening elements for connecting refractory bricks to the frame element, and

- the refractory bricks are connected to the frame element by using the fastening elements,

- wherein the fastening elements are at least partly composed of elongate fastening strips made of steel, and

- wherein the elongate fastening steel strips are fastened to the frame element so that the elongate fastening steel strips together form in between them an open

interspace, which is narrowed in a direction pointed away from the bottom of the open interspace formed by a surface of the frame element,

characterized in that the elongate fastening steel strips are fastened to the frame element so that two elongate fastening steel strips together form in between
5 them an open interspace, which has an elongated form and configured to receive a plurality of refractory bricks,

in that in the open interspace, there are arranged such refractory bricks that the refractory bricks together form a uniform structure, which is located essentially completely in the open interspace, the measures and shape of said structure at least
10 partly corresponding to the measures and shape of the open interspace,

in that to the frame element there is fastened at least one elongate fastening steel strip, the cross-sectional area of which expands in a direction pointed away from the bottom of the open interspace, so that the open interspace created between two elongate fastening steel strips is narrowed in a direction pointed away from the bottom
15 of the open interspace formed by the surface of the frame element, and

in that the the elongate fastening steel strips are fastened to the frame element by means of dovetail type joints.

In an embodiment, the present invention provides a cooling element to be used in connection with a metallurgical furnace or the like, being mainly made of copper and provided with water cooling channels, said cooling element comprising
20

- a frame element that is mainly made of copper and provided with water cooling channels,

- refractory bricks, and

- fastening elements for connecting the refractory bricks to the frame element,

- wherein the fastening elements are at least partly formed of elongate fastening strips made of steel, and

- wherein the elongate fastening steel strips are fastened to the frame element so that the elongate fastening steel strips together form in between them an open interspace, which is narrowed in a direction pointed away from the bottom of the open interspace formed by a surface of the frame element,
30

characterized in that the elongate fastening steel strips are fastened to the frame element so that two elongate fastening steel strips together form in between them an open interspace, which has an elongated form and configured to receive a plurality of refractory bricks,

in that the refractory bricks together form a uniform structure, which is located essentially completely in the open interspace, the measures and shape of said structure at least partly corresponding to the measures and shape of the open interspace,
35

2B

in that to the frame element there is fastened at least one elongate fastening steel strip, the cross-sectional area of which expands in a direction pointed away from the bottom of the open interspace, so that the open interspace created between two elongate fastening steel strips is narrowed in a direction pointed away from the bottom of the open interspace formed by the surface of the frame element, and

in that the the elongate fastening steel strips are fastened to the frame element by means of dovetail type joints.

The method according to the invention is based on the principle that the fastening elements are at least partly composed of elongate fastening strips made of

steel, which strips are fastened to the frame element, so that the elongate fastening steel strips together form in between them an open interspace that is narrowed in the direction pointed away from the bottom of the open interspace, and that the refractory bricks are arranged in the open interspace so that said refractory bricks are located at least partly in said open interspace.

A cooling element according to the invention is provided with fastening elements for connecting refractory bricks to the frame element. The fastening elements are at least partly formed of elongate fastening strips made of steel. The elongate fastening steel strips are fastened to the frame element so that the elongate fastening steel strips together form in between them an open interspace that is narrowed in the direction pointed away from the bottom of the open interspace. The open interspace is narrowed preferably, but not necessarily, in a wedge-like fashion in the direction pointed away from the bottom of the open interspace. The refractory bricks are arranged in the open interspace so that said refractory bricks are located at least partly in the open interspace that is narrowed in the direction pointed away from the bottom of the open interspace.

In an arrangement according to the invention, the open interspace that is narrowed in the direction pointed away from the bottom of said open interspace prevents the frame element from moving with respect to the bricks and vice versa. As a result, there is obtained a good joint between the frame element and the brick, and as a consequence, thermal energy is efficiently transferred in between the frame element and the brick.

In a preferred embodiment of the arrangement according to the invention, in the open interspace there are arranged such refractory bricks that the refractory bricks together form a uniform structure, said structure including a section located in the open interspace and having measures and shape that at least partly correspond to the measures and shape of the open interspace. In this way, there is obtained a joint corresponding to a form-fitted joint in between the refractory bricks and the frame element, which joint is capable of efficiently preventing the refractory bricks from moving with respect to the frame element, and which thus ensures good heat transfer properties in between the refractory bricks and the frame element.

In a preferred embodiment of the arrangement according to the invention, in the open interspace there are arranged such refractory bricks that said refractory bricks together form a uniform structure, which is located essentially completely in the open interspace and has measures and shape that at least partly correspond to the measures and shape of the open interspace. In this way, there is obtained a joint corresponding to a form-fitted joint in between the refractory bricks and the frame element, which joint is capable of efficiently preventing the refractory bricks from

moving with respect to the frame element, and which thus ensures good heat transfer properties in between the refractory bricks and the frame element.

In a preferred embodiment of the arrangement according to the invention, the open interspace is created by fastening the elongate fastening steel strips to the frame element so that the open interspace, which is narrowed in the direction pointed away from the bottom of the open interspace, is formed in between two elongate fastening steel strips, and so that the bottom of the open interspace is configured of the surface of the frame element. In this way, the joint obtained in between the refractory bricks and the frame element has good properties for transferring thermal energy, because the refractory bricks are in direct contact with the frame element, and this ensures good heat transfer properties in between the refractory bricks and the frame element.

In a preferred embodiment of the arrangement according to the invention, the open interspace is created by fastening the elongate fastening steel strips to the frame element, so that the open interspace is created in between two elongate fastening steel strips, and to the frame element there is fastened at least one elongate fastening steel strip, the cross-sectional area of which expands in the direction pointed away from the bottom of the open interspace, so that the open interspace formed in between two elongate fastening steel strips is narrowed in the direction pointed away from the bottom of the open interspace.

In a preferred embodiment of the arrangement according to the invention, the elongate fastening steel strip is fastened to the frame element by machining in the frame element an elongate groove for an elongate fastening steel strip, so that the measures and shape of the section of the elongate fastening steel strip that is to be fitted in the elongate groove essentially correspond to the measures and shape of the elongate groove for realizing a friction-fitted or form-fitted joint in between the elongate fastening steel strip and the elongate groove.

In a preferred embodiment of the arrangement according to the invention, the elongate fastening steel strips are made of stainless steel, the chromium content of which is over 10.5%, advantageously of stainless steel according to the standard EN 10095 (Fireproof steels and nickel alloys).

In a preferred embodiment of the arrangement according to the invention, the elongate fastening steel strips are made of stainless steel, the chromium content of which is of the order 17 – 30%, such as 22 – 24%, 24 – 29%, or 29 – 30%.

In a preferred embodiment of the arrangement according to the invention, there is provided a stopping piece for holding the refractory bricks in the open interspace, and said stopping piece is arranged so that it is located in between two elongate fastening steel strips, and so that it is located at the other end of the interspace formed in between two elongate fastening steel strips. In particular, in case

the open interspace shall extend vertically when using the cooling element, the cooling element must have an arrangement for holding the refractory bricks in the open interspace, and this kind of stopping piece is well suited in this purpose.

List of drawings

5 A few preferred embodiments of the invention are described in more detail below with reference to the appended drawings, where

Figure 1 illustrates a structure comprising several cooling elements,

Figure 2 illustrates a preferred embodiment of a cooling element according to the invention, including a frame element to which there are fastened elongate
10 fastening steel strips, and a stopping piece in between the elongate fastening steel strips, and

Figure 3 illustrates the cooling element of Figure 2, viewed from another angle.

Detailed description of invention

15 The invention relates to a method for manufacturing a cooling element 1 to be used in connection with a metallurgical furnace or the like, and to a cooling element 1 to be used in connection with a metallurgical furnace or the like, being mainly made of copper and provided with water cooling channels 2.

20 The method according to the invention for manufacturing a cooling element 1 to be used in connection with a metallurgical furnace or the like is described in more detail first.

In the method, there is provided a frame element 3 being mainly made of copper and provided with water cooling channels 2.

25 In the method, in the frame element 3 there are provided fastening elements 4 for connecting refractory bricks 6 to the frame element 3. The refractory bricks 6 are advantageously connected to that surface of the frame element 3 that is turned to face the molten metal, when the cooling element 1 is installed in a metallurgical furnace or the like, and when the cooling element 1 is being used in a metallurgical furnace or the like.

30 In the method, refractory bricks 6 are connected to the frame element 3 by using fastening elements 4.

In the method, the fastening elements 4 are at least partly made of elongate fastening strips made of steel 5. The elongate fastening steel strips 5 are fastened to the frame element 3 so that the elongate fastening steel strips 5 together form in
35 between them an open interspace 7, which is narrowed in a direction pointed away from the bottom 8 of the open interspace 7. The refractory bricks 6 are arranged in the

open interspace 7, so that the refractory bricks 6 are located at least partly in the open interspace 7.

The open interspace 7 is narrowed preferably, but not necessarily, in a wedge-like fashion in a direction pointed away from the bottom 8 of the open interspace 7.

5 The elongate fastening steel strips 5 are fastened preferably, but not necessarily, to the frame element 3 so that in the frame element, there are made, for example by machining, elongate grooves 10 for the elongate fastening steel strips 5. In case the frame element 3 is provided with elongate grooves 10 for the elongate fastening steel strips 5, the elongate grooves 10 are made preferably, but not
10 necessarily, so that in between an elongate groove 10 and an elongate fastening steel strip 5, there is created a form-fitted or friction-fitted joint for holding the elongate fastening steel strip 5 in the elongate groove 10. In the drawings, in between each elongate groove 10 and each elongate fastening steel strip 5, there is made a dovetail type joint. As an alternative, the elongate fastening steel strips 5 can also be cast
15 directly in the frame element 3, for example in one and the same casting step, in case the frame element 3 is manufactured by casting.

In the method, in the open interspace 7 there are arranged preferably, but not necessarily, such refractory bricks 6 that the refractory bricks 6 together form a uniform structure having a section placed in the open interspace 7, the measures and
20 shape of said section at least partly corresponding to the measures and shape of the open interspace 7.

In the method, in the open interspace 7 there are arranged preferably, but not necessarily, such refractory bricks 6 that the refractory bricks 6 together form a uniform structure, which is located essentially completely in the open interspace 7 and
25 the measures and shape of which least partly correspond to the measures and shape of the open interspace 7.

The open interspace 7 is made preferably, but not necessarily, by fastening the elongate fastening steel strips 5 to the frame element 3, so that the open interspace 7 is formed in between two elongate fastening steel strips 5.

30 The elongate fastening steel strips 5 are fastened to the frame element 3 preferably, but not necessarily, so that the bottom 8 of the open interspace 7 is at least partly, but preferably completely, formed of the surface of the frame element 3.

In the method, to the frame element 3 there is preferably, but not necessarily, fastened at least one elongate fastening steel strip 5, the cross-sectional area of which
35 expands in a direction pointed away from the bottom 8 of the open interspace 7, so that the open interspace formed in between two elongate fastening steel strips 5 is narrowed in a direction pointed away from the bottom 8 of the open interspace 7.

The elongate fastening steel strips 5 are preferably, but not necessarily, made of stainless steel, the chromium content of which is over 10.5%, advantageously of stainless steel according to the standard EN 10095 (Fireproof steels and nickel alloys).

5 The elongate fastening steel strips 5 can be preferably, but not necessarily, made of stainless steel, the chromium content of which is of the order 17 – 30%, such as 22 – 24%, 24 – 29%, or 29 – 30%.

10 In the method, there is preferably, but not necessarily, provided a stopping piece 9 for holding the refractory bricks 6 in the open interspace 7. The stopping piece 9 is preferably, but not necessarily, arranged so that it connects two elongate fastening steel strips 5, and so that it is located at the other end of the interspace 7 formed in between two elongate fastening steel strips 5.

The invention also relates to a cooling element 1 to be used in connection with a metallurgical furnace or the like, said cooling element being mainly made of copper and provided with water cooling channels 2.

15 The cooling element 1 comprises a frame element 3 that is mainly made of copper and provided with water cooling channels 2.

In addition, the cooling element 1 comprises refractory bricks 6 and fastening elements 4 for connecting the refractory bricks 6 to the frame element 3.

20 The fastening elements 4 are at least partly formed of elongate fastening strips made of steel 5.

25 The elongate fastening steel strips 5 are fastened to the frame element 3, so that the elongate fastening steel strips 5 together form in between them an open interspace 7, which is narrowed in a direction pointed away from the bottom 8 of the open interspace 7. The open interspace 7 is preferably, but not necessarily, narrowed in a wedge-like fashion in a direction pointed away from the bottom 8 of the open interspace 7.

The refractory bricks 6 are arranged in the open interspace 7 so that the refractory bricks 6 are located at least partly in the open interspace 7.

30 The elongate fastening steel strips 5 are preferably, but not necessarily, fastened to the frame element 3, so that in the frame element 3, there is made, for instance by machining, elongate grooves 10 for the elongate fastening steel strips 5. In case elongate grooves 10 are made in the frame element 3 for the elongate fastening steel strips 5, the elongate grooves 10 are preferably, but not necessarily, made so that in between an elongate groove 10 and an elongate fastening steel strip 5, there is created a form-fitted or friction-fitted joint for holding the elongate fastening steel strip 5 in the elongate groove 10. In the drawings, in between each elongate groove 10 and each elongate fastening steel strip 5, there is formed a dovetail type joint. As an alternative, the elongate fastening steel strips 5 can be cast directly in the frame

element 3, for example in the same casting step, in case the frame element 3 is manufactured by casting.

Together the refractory bricks 6 form preferably, but not necessarily, a uniform structure that includes a section located in the open interspace 7, the measures and shape of said section at least partly corresponding to the measures and shape of the open interspace 7.

As an alternative, the refractory bricks 6 can together form, preferably, but not necessarily, a uniform structure that is located essentially completely in the open interspace 7, the measures and shape of said structure at least partly corresponding to the measures and shape of the open interspace 7.

The open interspace 7 is created preferably, but not necessarily, by fastening the elongate fastening steel strips 5 to the frame element 3, so that the open interspace 7 is created between two elongate fastening steel strips 5.

The elongate fastening steel strips 5 are preferably, but not necessarily, fastened to the frame element 3 so that the bottom 8 of the open interspace 7 is formed of at least partly of the surface of the frame element 3.

To the frame element 3, there is preferably, but not necessarily, fastened at least one elongate fastening steel strip 5, the cross-sectional area of which expands in a direction that is pointed away from the bottom 8 of the open interspace 7, so that the open interspace 7 created between two elongate fastening steel strips 5 is narrowed in a direction pointed away from the bottom 8 of the open interspace 7.

The elongate fastening steel strips 5 are preferably, but not necessarily, made of stainless steel, the chromium content of which is over 10.5%, preferably of stainless steel according to the standard EN 10095 (Fireproof steels and nickel alloys).

For example, the elongate fastening steel strips 5 are made of stainless steel, the chromium content of which is of the order 17 – 30%, such as 22 – 24%, 24 – 29% or 29 – 30%.

The cooling element 1 comprises preferably, but not necessarily, a stopping piece 9 for holding the refractory bricks 6 in the open interspace 7. The stopping piece 9 can be such that it connects two elongate fastening steel strips 5, so that the stopping piece 9 is located at the other end of the interspace 7 created in between two elongate fastening steel strips 5.

For a man skilled in the art, it is obvious that along with the development of technology, the basic idea of the invention can be realized in many different ways.

Thus the invention and its preferred embodiments are not restricted to the examples described above, but they can vary within the scope of the appended claims.

It is to be understood that, if any prior art publication is referred to herein, such reference does not constitute an admission that the publication forms a part of the common general knowledge in the art, in Australia or any other country.

In the claims which follow and in the preceding description of the invention, except where the context requires otherwise due to express language or necessary implication, the word “comprise” or variations such as “comprises” or “comprising” is used in an inclusive sense, i.e. to specify the presence of the stated features but not to preclude the presence or addition of further features in various embodiments of the invention.

5

10

Claims

1. A method for manufacturing a cooling element to be used in connection with a metallurgical furnace or the like, in which method

5 - there is arranged a frame element that is mainly made of copper and provided with water cooling channels,

- in the frame element, there are provided fastening elements for connecting refractory bricks to the frame element, and

10 - the refractory bricks are connected to the frame element by using the fastening elements,

- wherein the fastening elements are at least partly composed of elongate fastening strips made of steel, and

15 - wherein the elongate fastening steel strips are fastened to the frame element so that the elongate fastening steel strips together form in between them an open interspace, which is narrowed in a direction pointed away from the bottom of the open interspace formed by a surface of the frame element,

20 characterized in that the elongate fastening steel strips are fastened to the frame element so that two elongate fastening steel strips together form in between them an open interspace, which has an elongated form and configured to receive a plurality of refractory bricks,

25 in that in the open interspace, there are arranged such refractory bricks that the refractory bricks together form a uniform structure, which is located essentially completely in the open interspace, the measures and shape of said structure at least partly corresponding to the measures and shape of the open interspace,

30 in that to the frame element there is fastened at least one elongate fastening steel strip, the cross-sectional area of which expands in a direction pointed away from the bottom of the open interspace, so that the open interspace created between two elongate fastening steel strips is narrowed in a direction pointed away from the bottom of the open interspace formed by the surface of the frame element, and

in that the the elongate fastening steel strips are fastened to the frame element by means of dovetail type joints.

2. The method according to claim 1, **characterized** by making the elongate fastening steel strips of stainless steel, the chromium content of which is over 10.5%.

35 3. The method according to claim 2, **characterized** in that the chromium content ranges from 17 – 30%.

4. The method according to claim 2, **characterized** in that the chromium content ranges from 22 – 24%.

5 5. The method according to claim 2, **characterized** in that the chromium content ranges from 24 - 29%.

6. The method according to claim 2, **characterized** in that the chromium content ranges from 29 – 30%.

10

7. The method according to any of the preceding claims 1, **characterized** by providing a stopping piece for holding the refractory bricks in the open interspace.

8. The method according to any of the preceding claims, **characterized** in that the open interspace is created by fastening elongate fastening steel strips to the frame element so that the bottom of the open interspace is at least partly formed of the surface of the frame element.

9. A cooling element to be used in connection with a metallurgical furnace or the like, being mainly made of copper and provided with water cooling channels, said cooling element comprising

20 - a frame element that is mainly made of copper and provided with water cooling channels,

- refractory bricks, and

25 - fastening elements for connecting the refractory bricks to the frame element,

- wherein the fastening elements are at least partly formed of elongate fastening strips made of steel, and

30 - wherein the elongate fastening steel strips are fastened to the frame element so that the elongate fastening steel strips together form in between them an open interspace, which is narrowed in a direction pointed away from the bottom of the open interspace formed by a surface of the frame element,

35 characterized in that the elongate fastening steel strips are fastened to the frame element so that two elongate fastening steel strips together form in between them an open interspace, which has an elongated form and configured to receive a plurality of refractory bricks,

in that the refractory bricks together form a uniform structure, which is located essentially completely in the open interspace, the measures and shape of said structure at least partly corresponding to the measures and shape of the open interspace,

in that to the frame element there is fastened at least one elongate fastening steel strip, the cross-sectional area of which expands in a direction pointed away from the bottom of the open interspace, so that the open interspace created between two elongate fastening steel strips is narrowed in a direction pointed away from the bottom of the open interspace formed by the surface of the frame element, and

in that the the elongate fastening steel strips are fastened to the frame element by means of dovetail type joints.

10. The cooling element according to claim 9, **characterized** in that the elongate fastening steel strips are made of stainless steel, the chromium content of which is over 10.5%.

11. The cooling element according to claim 10, **characterized** in that the chromium content ranges from 17 – 30%.

12. The cooling element according to claim 10, **characterized** in that the chromium content ranges from 22 – 24%.

13. The cooling element according to claim 10, **characterized** in that the chromium content ranges from 24 – 29%.

14. The cooling element according to claim 10, **characterized** in that the chromium content ranges from 29 – 30%.

15. A cooling element according to any of the claims 9 - 14, **characterized** in that the cooling element comprises a stopping piece for holding the refractory bricks in the open interspace.

16. A cooling element according to any of the claims 9 - 15, **characterized** in that the bottom of the open interspace is formed of at least partly of the surface of the frame element.

17. A method for manufacturing a cooling element to be used in connection with a metallurgical furnace or the like substantially as herein described with reference to the accompanying figures.

18. A cooling element to be used in connection with a metallurgical furnace or the like substantially as herein described with reference to the accompanying figures.

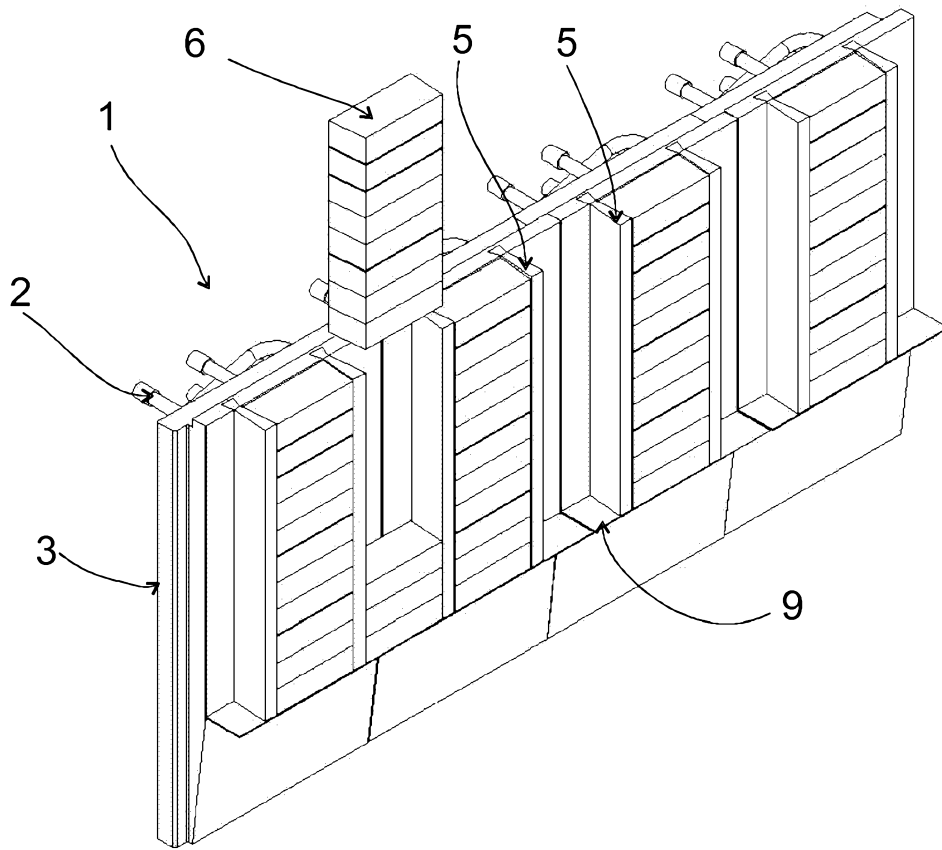

Fig1

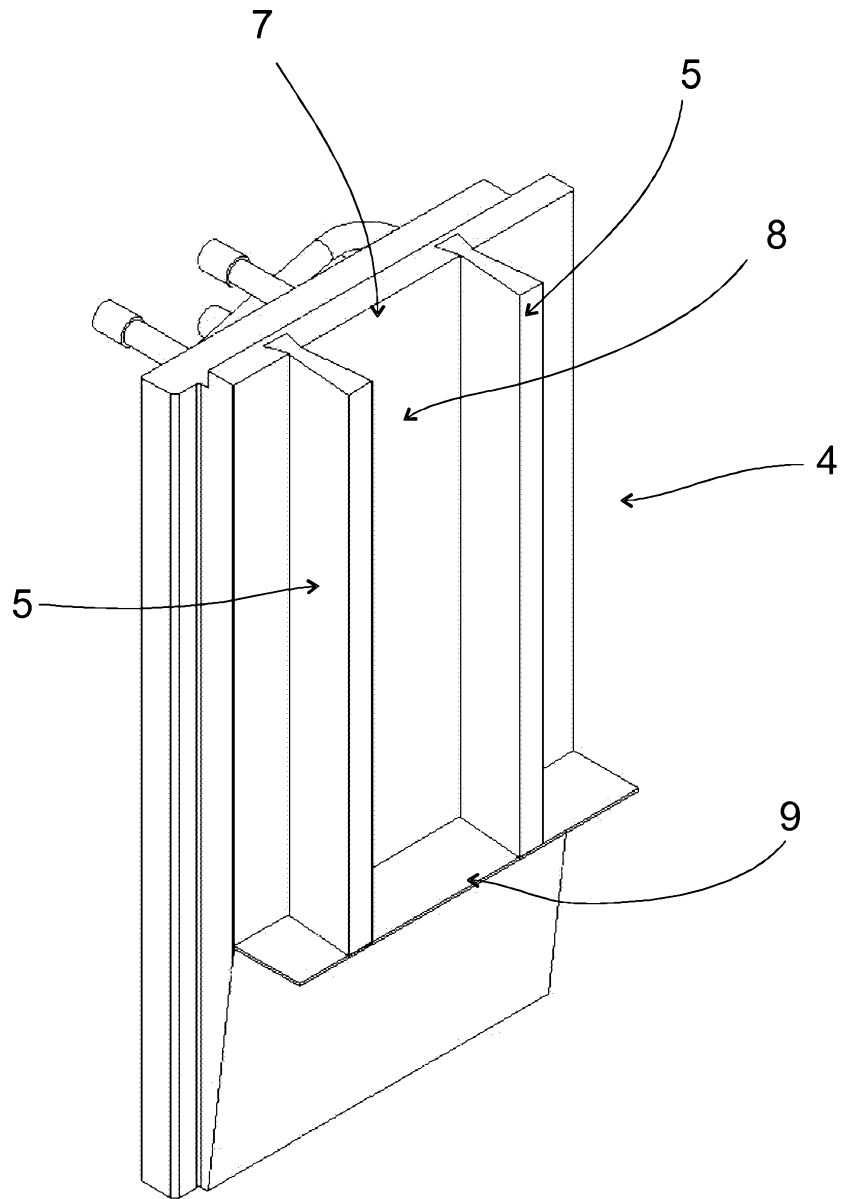

Fig2

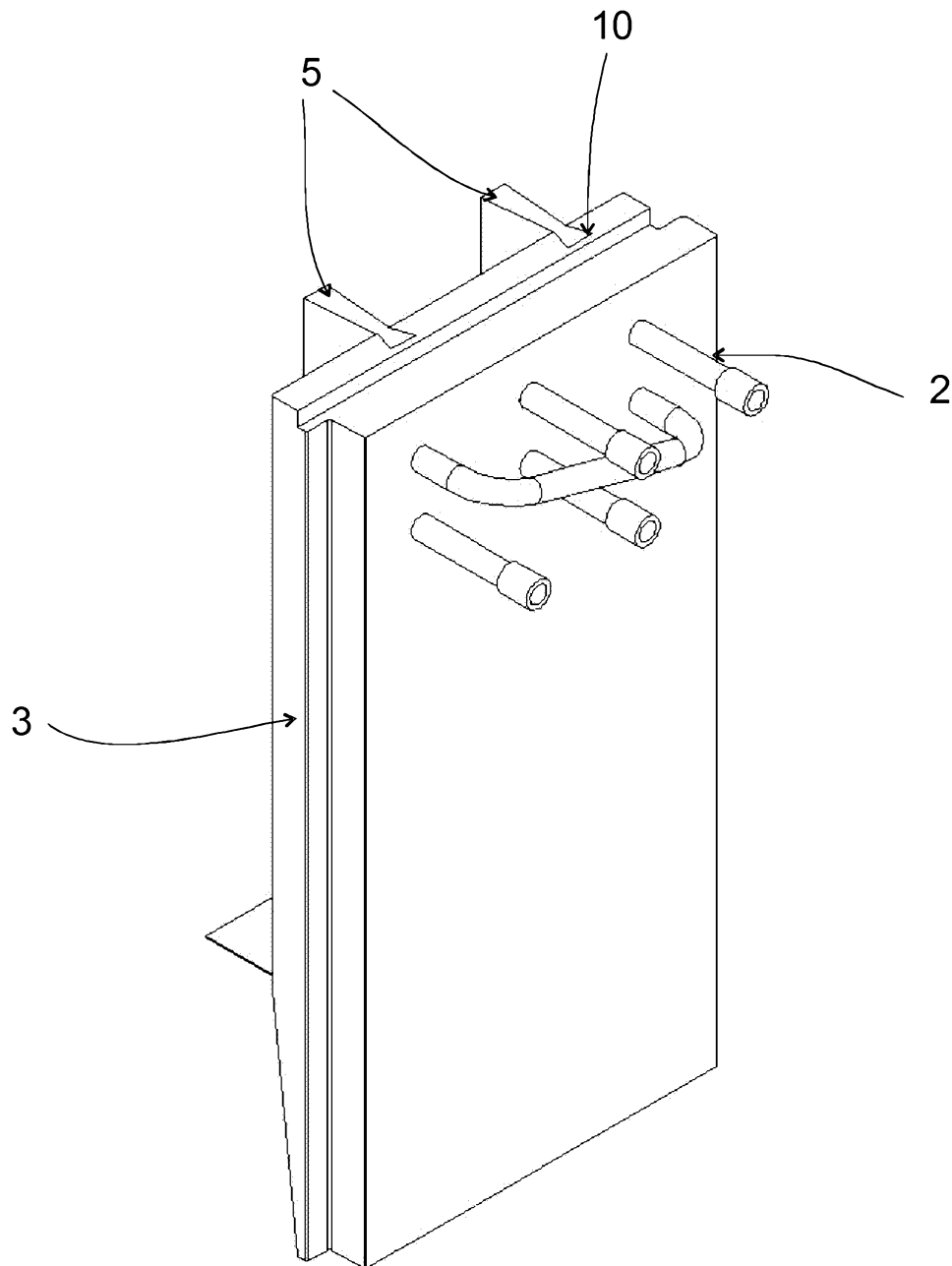

Fig3