

J. B. RYAN.
BED.

No. 540,194.

Patented May 28, 1895.

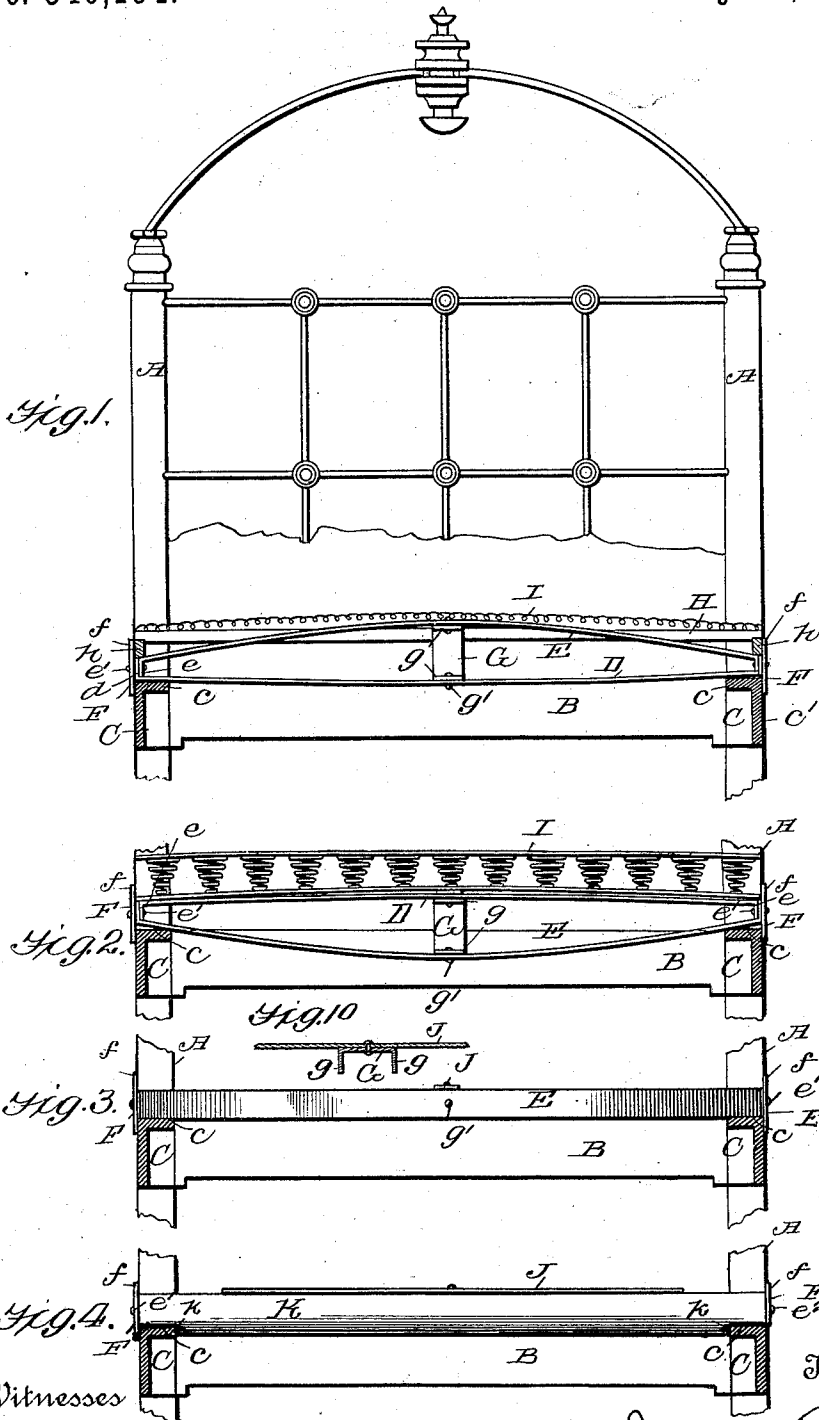

Witnesses
 Jos. b. Stack.
 L. Fischer.

Inventor
 James B. Ryan
 by *[Signature]*
 Attorney

J. B. RYAN.
BED.

No. 540,194.

Patented May 28, 1895.

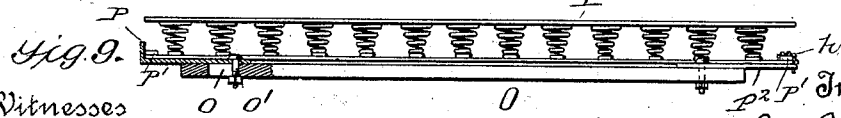
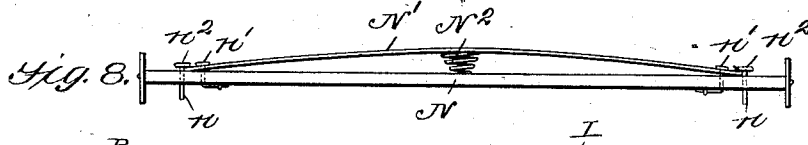
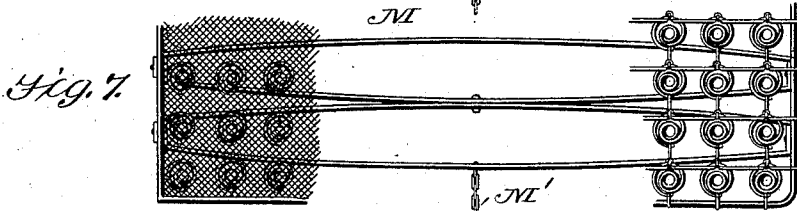
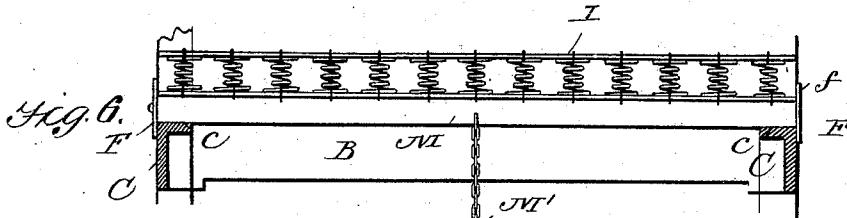
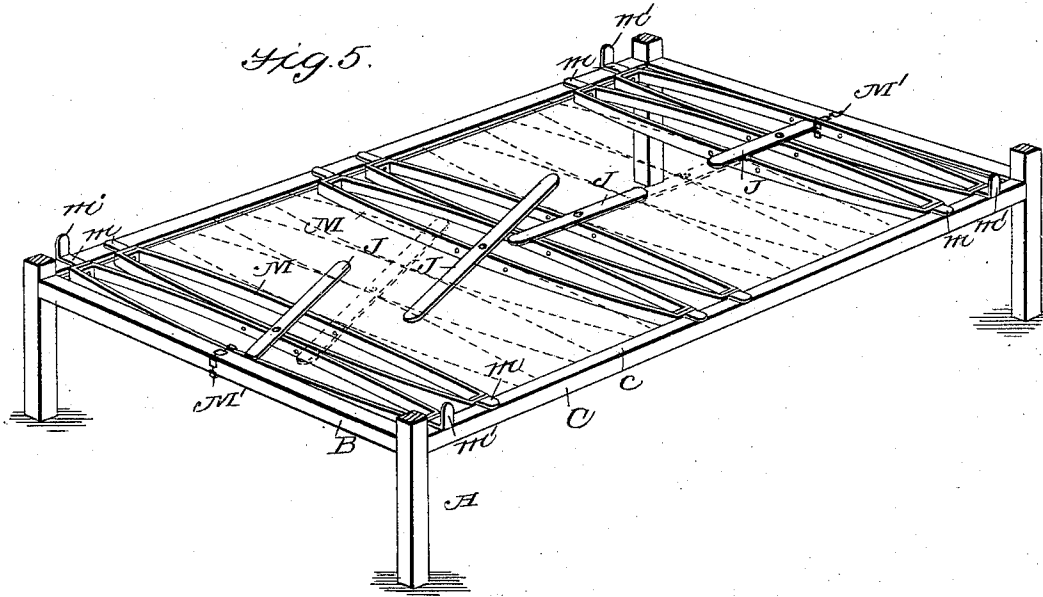

Witnesses
 Jos. B. Stack.
 L. C. Kruse

Inventor
 James B. Ryan
 J. W. Doubleday
 Attorney

UNITED STATES PATENT OFFICE.

JAMES B. RYAN, OF NEW YORK, N. Y.

BED.

SPECIFICATION forming part of Letters Patent No. 540,194, dated May 28, 1895.

Application filed February 28, 1895. Serial No. 540,088. (No model.)

To all whom it may concern:

Be it known that I, JAMES B. RYAN, a citizen of the United States, residing at New York, in the county of New York and State of New York, have invented certain new and useful Improvements in Beds, of which the following is a specification, reference being had therein to the accompanying drawings.

Figure 1 is a transverse vertical section of so much of a bedstead and spring-bed applied thereto as is necessary to illustrate my invention. Fig. 2 represents a similar section with some of the parts of my device in a different position. Fig. 3 represents a further modification in the position of some of the parts. Fig. 4 is a modification in which I use a wooden slat. Figs. 5, 6, 7, 8, and 9 show other modifications with wooden slats.

Like reference-letters indicate similar parts in all the figures.

Referring particularly to Figs. 1, 2, and 3, A are the posts and B the head rail of an ordinary bedstead. C, c, are the side rails, preferably of angle iron, with the horizontal flange c uppermost; but, of course, my invention is adapted for use upon wooden bedsteads. D, E, are metal bars or strips bent to form overlapping ears or lugs d, e and perforated to receive rivets e'. F, f, are short plates or bars preferably of thin metal and attached, about midway between their ends to the outer bent up ends of the bars, D, preferably by the same rivets e' which hold the bars together, the bars being of such length that the lower ends F of those plates fit closely the outer faces of the bed rails as shown in Fig. 1 and thus serve as stops to prevent endwise movement of the bars. So, also, such close fitting of parts maintains the bars at practically right angles to the side rails of the bedstead. G, g, g, is a transverse girt or tie arranged about midway between the ends of the bars and secured thereto by rivets g', passing through the bars and the bent ends g, whereby the girt braces the two bars at proper distances apart, and supports them against twisting strain, thus relieving the rivets e'. H, h, are the end and side rails of the frame of an ordinary woven wire mattress of such width that the side rails fit closely between the ends f, f, of the plates and are prevented from moving sidewise. I have in this figure shown a spring bed of this

type, not because I generally prefer to use such, but in order to illustrate more clearly how, by a decidedly curved upper bar, the central portion of the bed may be so elevated above its sides as to insure that that part will not sag below its edges when occupied under ordinary circumstances. It will be seen that in this figure the upper bar E has a much greater curve in longitudinal section than has the lower bar D; but in some of the other figures (see particularly Figs. 2, 6, and 9,) I have shown a number of other well known constructions of spring bed in combination with my invention, for the purpose of more fully illustrating its usefulness in supporting a variety of different makes of beds. By the use of the stops f, f, frame, or cross slats, as the case may be, can extend the full width of the side rails of the bedstead without danger of accidental displacement transversely of the bedstead. In Fig. 2 the position of the bars D, E, is reversed, the upper surfaces of the bars D being in nearly a plane. J is a supporting strip, or plate, of which I propose to employ a series arranged longitudinally of the bed and preferably attached to part or all of the bars D or E, whichever may be uppermost, to form an additional support for the mattress or other style of bed. In these figures I have shown a single line of bars J disposed about midway between the side rails of the bed; but it is evident that two or more parallel rows might be used where the width of the bed shall make it desirable.

In Figs. 3, 6 and 7 I have shown the bars D, E, disposed with their edges uppermost to receive the weight of the bed and its occupant, whereby a much more rigid support is provided in proportion to the weight of metal employed; and under such an arrangement I propose to attach the longitudinal bars J to the girts G, g. I prefer to use rivets for attaching the bars so that they will serve as pivots and permit the bars J to be turned practically in line with the bars D, E to save room during storage or transportation. With bars turned up edgewise I propose to combine chains which may be used alternately for stretching out the bars, the weight of said bars being wholly supported by their ends resting upon the upper faces of the bed rails, and for retaining the bars in a compressed

bundle-like condition for transportation, the chains serving as bands for that purpose. By making the bars D, E, curved in form as indicated and tying them together between
 5 their ends by the girts I secure the requisite strength and elasticity with comparatively small weight of metal; thus providing a useful support for a bed irrespective of the woven wire fabric I. Under some circumstances I
 10 propose to substitute for such wire fabric a bed bottom having a series of transverse slats and interposed springs such, for instance, as is shown in my Patent No. 524,955.

In Fig. 4 I have shown a modification in
 15 which K is a wooden slat, preferably round in cross section and of a length about equal to the width of the bed, with its under surface cut away to form flat faces for resting upon the upper sides or edges of the side rails of the bedstead, with shoulders *k*, *k* abutting
 20 against said side rails and preventing endwise movement of the slats. With these wooden slats I also combine similar short plates F, *f*, to serve as stops for the side rails of the mattress frame, preferably securing the plates to
 25 the wooden bars by ordinary wood screws which will take a firm hold of said bars. With these wooden bars I also propose to combine longitudinal bars J pivoted thereto at their
 30 centers.

It is apparent that in all the figures the bars J may be so disposed as to form a sort of flooring between the transverse bars, however many of the latter may be used, and prevent the bedding from falling through between said bars; the bars J also assisting in preventing the transverse bar from tipping
 35 over.

In Fig. 5 I have shown a series of flat metal
 40 bars M, M, bent at their ends to overlap; which parts are riveted together, the adjacent pairs of the series having their flat sides riveted to each other. These bars are somewhat shorter relative to the width of the bed than those heretofore described so that they
 45 fit in between the side rails, they being provided with hangers or bracket pieces *m*, *m'*, which are attached to the outer overlapping ends and rest upon the upper faces of the
 50 side rails, whereby the upper edges of the bars are supported in about the plane of the said upper edges of the side rails. By preference the hangers, or at least those near the head and foot of the bed, have upturned ears
 55 or lugs *m'* which serve as stops to prevent sidewise movement of the mattress frame, or of whatever form of spring bed is used. M', M', are links or ties, preferably in the form of chains connecting the head and foot bars with
 60 the head and foot rails of the bedstead so that by hooking the free end of each of the chains, or of one of them, into one or another of the chain links a series of such riveted
 65 bars may be stretched out to fit beds of different lengths; the number of bars and their relative positions being regulated according to the requirements in each case. By the use of

the bracket pieces having lugs *m* practically in the plane of the upper edges of the bars M and upturned ears *m'* practically in the vertical planes of the outer faces of the side rails
 70 of the bed I am enabled to use and properly support a mattress the outer edges of which are practically in the same vertical planes with the outer faces of the side rails of the
 75 bedstead.

In Fig. 6 which shows a bar in elevation, and Fig. 7, which shows two bars in plan I have provided for the use of a spring mattress of the same width as the bed without
 80 the employment of brackets for suspending the bars M which, in this figure, are long enough so that their ends rest directly upon the side rails; in which respect these bars M correspond with bars D, E; and to insure that
 85 the bars shall always properly stand upedgewise I rivet, or otherwise fasten, one bar of each pair to one bar of an adjacent pair. In fact, in order to secure the best results, I propose to rivet both bars of each pair to bars of
 90 adjacent pairs throughout the entire length of the bed; but they may obviously be used in pairs or singly as is provided for in case of the bars shown in Figs. 1, 2, and 3. With the
 95 outer ends of each pair I propose to combine short plates F, *f*, substantially the same as I have shown in Figs. 1, 2, 3, and 4, and for the same purpose.

In the modification shown in Fig. 8 N is a wooden slat as long as the bed is wide preferably straight on its under surface, with stops
 100 projecting down from its under side as at *n*, *n* to prevent endwise movement. N' is a semi-elliptical spring secured at its ends to the upper surface of the slat preferably, by a rivet
 105 or screw *n'* the length of the spring being such that its ends abut against stops *n*² which, in this instance are the upper ends of pins inserted in the slat and projecting below it to form the stops *n*, *n*. I usually provide these
 110 pins with projections at their upper ends to overlap the ends of the spring. Under some circumstances I combine with the spring N' and the slat another spring such as is indicated at N², for instance, as an additional support. In this modification F, *f*, are plates at
 115 the outer ends of the slat forming stops to restrict sidewise movement of the spring bed; and when the plate is made long enough to project below the slat and engage with the
 120 outer faces of the side rails of the bedstead the stops *n*, *n*, may be omitted.

In the modification shown in Fig. 8 at the left hand end the slat, preferably of wood, O is provided with a slot *o* near the end. P, *p* is
 125 a plate or bracket or carrier adjustably secured to the slat by a bolt *o'* through the slot *o*. Of course the slat may be provided at its other end with a similar adjustable plate or carrier; so that the upturned ends *p'* of the
 130 plates will serve as stops to restrict the sidewise movement of mattress frames of different widths.

It will be seen that in each of the forms

shown there is combined with the bar stops which are made adjustable by pivoting them to the ends of said bars, so that they (the stops) can be turned around into different positions relative to the bar ends as circumstances may render desirable either to serve as stops when the bars are placed in different positions, or to facilitate handling, packing, or shipping without danger of injury to either the stops or their rivets.

I am aware that a British patent to Sohon shows a "grid" composed of canes extending crosswise of the bed with their ends inserted in holes formed for their reception in longitudinal bars which are round in cross section and which project above the upper faces of the inserted canes, the outer faces of the said bars being about in the vertical planes of the outer faces of the bed rails; so that in order that the side rails of a mattress frame may rest upon the canes within the bars the frame must be narrower than the "bed" by about twice the diameter of one of the bars; these bars being indispensable in Sohon's invention because they are the only means by which he holds the two adjacent canes in proper relation to each other. In fact, were it not for the said bars he would have merely a lot of loose round canes with no means for keeping them in place on the bed; whereas, in my invention each bar is complete in itself so far as relates to its having a flat lower face, means for keeping it from moving endwise, and having stops attached to its ends for preventing sidewise movement of the mattress frame, said stops being preferably supported in the vertical planes of the outer faces of the bed rails.

While I have described the best mode now known to me for carrying out my invention I do not wish to be limited to the precise details

shown, because many modifications thereof will readily suggest themselves to a person skilled in the art without going outside of the spirit of my improvement.

What I claim is—

1. The combination with the bed rails, of the bars, and the pivoted bars attached to their upper faces and disposed transversely thereto and adapted to extend over a series of such bars and to engage with and support the mattress, substantially as set forth.

2. The combination with the bed rails, of the bars, and adjustable stops pivoted to the ends of the bars and adapted to be turned alternately into vertical and horizontal positions, substantially as set forth.

3. The combination with the bed rails, of the bars, and adjustable stops pivoted to the ends of the bars and projecting above the bars to engage with the mattress frame and projecting below the bars to engage with the bed rails, substantially as set forth.

4. The combination with the metal strips bent inward at their ends, of the short plates attached to the bent ends and projecting above and below the bars, and adapted to engage with the bed rails and the mattress rails and to serve as stops, substantially as set forth.

5. The combination with a series of pairs of bars set with their edges uppermost, of a series of transverse bars laid flat upon the upper edges and secured thereto by means of rivets which project downward between two adjacent bars, substantially as set forth.

In testimony whereof I affix my signature in presence of two witnesses.

JAMES B. RYAN.

Witnesses:

WILLIAM A. HAWES,
HERBERT RENVILLE.