

J. A. KIRBY.  
Car-Brake.

No. 200,313.

Patented Feb. 12, 1878.

Fig. 1.

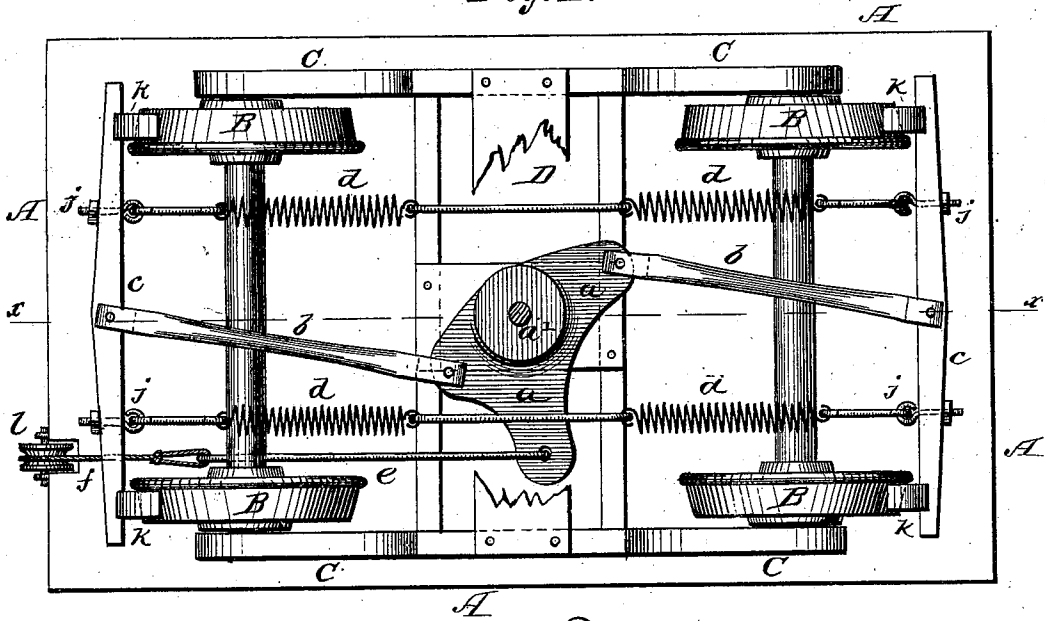

Fig. 2.

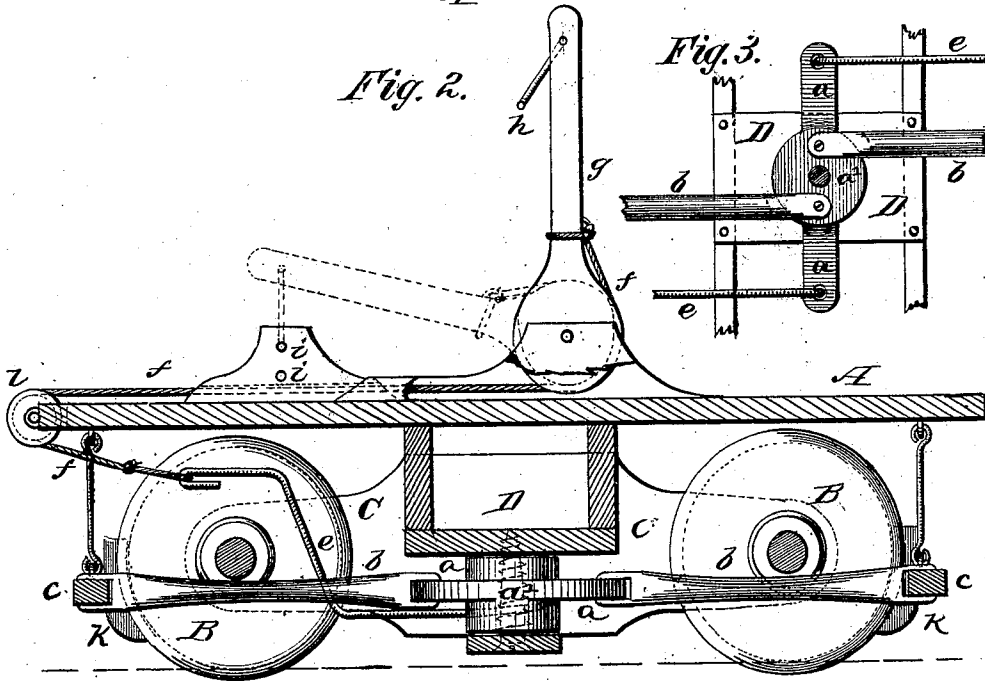
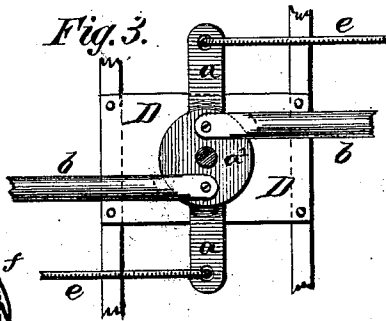

Fig. 3.



Witnesses:

*P. Dietrich*  
*Frank H. Duff*

Inventor:

*James A Kirby*  
Per *West & Bond Attorneys.*

# UNITED STATES PATENT OFFICE.

JAMES A. KIRBY, OF CHICAGO, ILLINOIS, ASSIGNOR OF TWO-THIRDS HIS RIGHT TO DANIEL J. AVERY AND JOSEPH W. TAFT, OF SAME PLACE.

## IMPROVEMENT IN CAR-BRAKES.

Specification forming part of Letters Patent No. 200,313, dated February 12, 1878; application filed July 20, 1877.

*To all whom it may concern:*

Be it known that I, JAMES A. KIRBY, of Chicago, in the county of Cook and State of Illinois, have invented certain new and useful Improvements in Car-Brakes; and I do hereby declare that the following is a full, clear, and exact description thereof, which will enable others skilled in the art to which it appertains to make and use the same, reference being had to the accompanying drawings, and to the letters of reference marked thereon, which form a part of this specification.

The object of my invention is to improve the construction and operation of brakes for single trucks, such as are used for freight, flat, and construction cars or street-cars; and its nature consists in connecting the brake-bars together by the springs, which furnish the pressure, in a system of levers and rods, by which the wheels are relieved from pressure, and in the several combinations of parts hereinafter described.

In the annexed drawing, Figure 1 is an under view of a car-truck with the central portion partly broken away; and Fig. 2, a longitudinal vertical section on line *x x*, Fig. 1. Fig. 3 is modification of the center lever.

In the drawings, A represents a portion of a flat car, or the bottom of any ordinary car; B, the wheels; C, the sides of the truck-frame; D, the central part of the truck-frame; *a*, the center lever; *a'*, fulcrum or pivot of center lever; *b b*, bars or rods connecting the center lever with the brake-bars; *c c*, brake-bars; *d d*, springs for applying pressure to the brake; *e*, rod or bar for operating the center lever; *f*, cord or rope connecting the rod *e* with the operating or hand lever; *g*, operating or hand lever; *h*, hook or catch; *i*, holes or notches for the catch; *j*, set-screws for adjusting the tension of the springs; *k*, brake-shoes; and *l*, anti-friction wheel or sheave.

The body of the car, a portion of which is represented at A, is made in any of the usual or well-known forms, as is also the truck-frame C D, except that the central part D may require modification in some of the forms to furnish a proper support and connection for the center lever. The center lever is centrally pivoted to the truck-frame at *a'*, and the bars

*b* are so connected therewith that when the center lever is operated they will be so nearly in line that but little power will be required keep them in position. The brake-bars *c* and shoes *k* are constructed in the usual manner, except that, as the power is applied to these bars near the wheels, they may be made very considerably lighter than those in common use, or they may be made of small iron bars. They are suspended from the ends of the truck or the body of the car by rods, in the usual manner.

The springs *d*, as shown, are helical, and are made of coiled steel rods, of sufficient size to give the required pressure, and are connected together and to the brake-bars by rods. It is evident, however, that one spring on each side of the truck may be placed in the middle of the rods, so that two springs will take the place of four, and that other forms of springs may be used.

The rope or cord *f* may be made of small wire-cable cordage, or partly of either or chains and partly of rods. At its lower end it is attached to the rod *e*, and at its upper end to the hand-lever *g*. In order to keep the cord *f* out of the way, it is carried around under the end of the hand-lever, as shown; but when this is not desired it may be attached without being carried under, in which case the hand-lever will be moved in an opposite direction from that shown.

The catch, having the holes *i*, is simply a block fastened to the bottom or deck of a car, and the catch *h* is simply a hook, as shown; but other forms of catches may be used.

In the form shown the brakes are off when the lever is in the position shown by the dotted lines, and all that is required to set the brake is for the brakeman to kick or push the hook out of the catch as he passes along, when the springs set the brake, so that, as he does not have to stop to set the brakes, he can operate more cars than one man can operate by the old systems or methods of hand-braking heretofore in use, which is especially desirable in long freight-trains.

It will be seen that the center lever *a*, located in the truck between the axles, serves a useful purpose independently of the springs,

as, by reversing the rod *e*, it, with the bars or rods *b*, may be used to set the brakes when the brake-bars are hung so as to fall away from the wheels when out of use, and to produce an equal pressure on all of the wheels in the truck. I prefer, however, to use it and its connections in combination with the springs *d*, as, by the use of springs, the brakes are set quicker, and the pressure on the wheels is perfectly equalized. The rod *e* may be a separate rod, as shown, or it may be a continuation of the cord *f*.

When the lever *g* is placed on the top or deck of a box-car, an additional wheel, *l*, will be placed at the upper turn of the cord *f*, and the lever is located near the end of the car, as brakes are only applied to one truck in freight, flat, or other coarse or cheap cars.

In operation, the brake is opened or placed out of contact with the wheels by placing the lever *g* into the position shown by the dotted lines of Fig. 2, in which position the lever is locked by the catch *h* or its equivalent. When the catch is released the springs *d* apply the brake-shoes to the wheels and return the lever *g* to its upright position. When the train is stopped the brakes are opened at leisure.

When the bars *c* are placed on the inside or between the wheels, as may be done on street-cars and long trucks, the operation is reversed, as in that construction the brakes

are set by the bars *b* and released by the springs, unless the springs are made to act by expansion instead of contraction, when the action will remain the same as shown, except that the lever *g* will be reversed in an opposite direction.

The center lever (shown at Fig. 3) is preferable for street or other cars when it is desired to operate a single brake from either end of the car.

What I claim as new, and desire to secure by Letters Patent, is—

1. The springs *d* and bars *c*, in combination with rods *b*, centrally-located lever *a*, and mechanism for operating the same, substantially as and for the purpose set forth.

2. The springs *d* and bars *c*, in combination with the lever *a*, bars *b*, rod or cord *e f*, and lever *g*, substantially as set forth.

3. The catch *h i*, in combination with the lever *g*, cord *f*, lever *a*, and bars *b*, for holding the brake-shoes out of contact with the wheels, substantially as specified.

In testimony that I claim the foregoing as my own I have hereto affixed my signature in presence of two witnesses.

JAMES A. KIRBY.

Witnesses:

E. A. WEST,  
O. W. BOND.