

(19) World Intellectual Property Organization  
International Bureau



(43) International Publication Date  
15 February 2001 (15.02.2001)

PCT

(10) International Publication Number  
**WO 01/10344 A1**

- (51) International Patent Classification<sup>7</sup>: A61F 2/02,  
A61K 9/52, 31/215, A61M 31/00, 5/32, C08K 3/28
- (21) International Application Number: PCT/US00/20566
- (22) International Filing Date: 28 July 2000 (28.07.2000)
- (25) Filing Language: English
- (26) Publication Language: English
- (30) Priority Data:  
09/368,119 4 August 1999 (04.08.1999) US
- (71) Applicant: C.R. BARD, INC. [US/US]; 730 Central Avenue, Murray Hill, NJ 07974 (US).
- (72) Inventors: TEDESCHI, Eugene; 3053 Porter Creek Road, Santa Rosa, CA 95404 (US). HUDSON, John,
- A.; 27 Fairview Drive, Wells, ME 04090 (US). SHAH, Chirag, B.; 28 New Castle Drive, #11, Nashua, NH 03060 (US).
- (74) Agent: PERULLO, John, F.; Kirkpatrick & Lockhart LLP, 75 State Street, Boston, MA 02109-1808 (US).
- (81) Designated States (*national*): CA, JP, MX.
- (84) Designated States (*regional*): European patent (AT, BE, CH, CY, DE, DK, ES, FI, FR, GB, GR, IE, IT, LU, MC, NL, PT, SE).
- Published:**  
— *With international search report.*
- For two-letter codes and other abbreviations, refer to the "Guidance Notes on Codes and Abbreviations" appearing at the beginning of each regular issue of the PCT Gazette.*



**WO 01/10344 A1**

(54) Title: NITRIC OXIDE RELEASING MEDICAL DEVICES

(57) Abstract: The present invention provides medical devices having a nitric oxide releasing compound associated with them for the purpose of altering the angiogenic activity in tissue surrounding the implant device. In particular, angiogenic implants configured for implantation in the myocardium of the heart are provided. The nitric oxide releasing compounds may be joined to the device in a polymer matrix coating or may be joined directly to the surface of the device after reaction with organosilane.

## NITRIC OXIDE RELEASING MEDICAL DEVICES

### Field of the Invention

The invention relates to medical devices that release nitric oxide to alter their  
5 angiogenic effect when implanted in tissue. Specifically, a method for adhering nitric  
oxide compounds to medical devices is provided so that the nitric oxide may be  
released gradually while implanted within tissue. Additionally, myocardial implants  
having nitric oxide releasing compounds are provided.

10

### Background of the Invention

Tissue becomes ischemic when it is deprived of adequate blood flow.  
Ischemia causes pain in the area of the affected tissue and, in the case of muscle  
tissue, can interrupt muscular function. Left untreated, ischemic tissue can become  
infarcted and permanently non-functioning. Ischemia can be caused by a blockage in  
15 the vascular system that prohibits oxygenated blood from reaching the affected tissue  
area. However, ischemic tissue can be revived to function normally despite the  
deprivation of oxygenated blood because ischemic tissue can remain in a hibernating  
state, preserving its viability for some time. Restoring blood flow to the ischemic  
region serves to revive the ischemic tissue. Although ischemia can occur in various  
20 regions of the body, often myocardial tissue of the heart is affected by ischemia.  
Frequently, the myocardium is deprived of oxygenated blood flow due to coronary  
artery disease and occlusion of the coronary artery, which normally provides blood to  
the myocardium. The ischemic tissue causes pain to the individual affected.

Treatment of myocardial ischemia has been addressed by several techniques  
25 designed to restore blood supply to the affected region. A conventional approach to  
treatment of ischemia has been to administer anticoagulants with the objective of  
increasing blood flow by dissolving thrombus or preventing formation of thrombus in  
the ischemic region.

Another conventional method of increasing blood flow to ischemic tissue of the  
30 myocardium is coronary artery bypass grafting (CABG). One type of CABG involves  
grafting a venous segment between the aorta and the coronary artery to bypass the

- 2 -

occluded portion of the artery. Once blood flow is redirected to the portion of the coronary artery beyond the occlusion, the supply of oxygenated blood is restored to the area of ischemic tissue.

Early researchers, more than thirty years ago, reported promising results for revascularizing the myocardium by piercing the muscle to create multiple channels for blood flow. Sen, P.K. et al., "Transmyocardial Acupuncture - A New Approach to Myocardial Revascularization", *Journal of Thoracic and Cardiovascular Surgery*, Vol. 50, No. 2, August 1965, pp. 181-189. Although researchers have reported varying degrees of success with various methods of piercing the myocardium to restore blood flow to the muscle (which has become known generally as transmyocardial revascularization or TMR), many have faced common problems such as closure of the created channels. Various techniques of perforating the muscle tissue to avoid closure have been reported by researchers. These techniques include piercing with a solid sharp tip wire, or coring with a hypodermic tube. Reportedly, many of these methods produced trauma and tearing of the tissue that ultimately led to closure of the channel.

An alternative method of creating channels that potentially avoids the problem of closure involves the use of laser technology. Researchers have reported success in maintaining patent channels in the myocardium by forming the channels with the heat energy of a laser. Mirhoseini, M. et al., "Revascularization of the Heart by Laser", *Journal of Microsurgery*, Vol. 2, No. 4, June 1981, pp. 253-260. The laser was said to form channels in the tissue that were clean and made without tearing and trauma, suggesting that scarring does not occur and the channels are less likely to experience the closure that results from healing. U.S. Patent No. 5,769,843 (Abela et al.) discloses creating laser-made TMR channels utilizing a catheter based system. Abela also discloses a magnetic navigation system to guide the catheter to the desired position within the heart. Aita patents 5,380,316 and 5,389,096 disclose another approach to a catheter based system for TMR.

Although there has been some published recognition of the desirability of performing TMR in a non-laser catheterization procedure, there does not appear to be evidence that such procedures have been put into practice. U.S. Patent No.

5,429,144 (Wilk) discloses inserting an expandable implant within a preformed channel created within the myocardium for the purposes of creating blood flow into the tissue from the left ventricle.

Performing TMR by placing stents in the myocardium also is disclosed in U.S. Patent No. 5,810,836 (Hussein et al.). The Hussein patent discloses several stent embodiments that are delivered through the epicardium of the heart, into the myocardium and positioned to be open to the left ventricle. The stents are intended to maintain an open channel in the myocardium through which blood enters from the ventricle and perfuses into the myocardium.

10 Angiogenesis, the growth of new blood vessels in tissue, has been the subject of increased study in recent years. Such blood vessel growth to provide new supplies of oxygenated blood to a region of tissue has the potential to remedy a variety of tissue and muscular ailments, particularly ischemia. Primarily, study has focused on perfecting angiogenic factors such as human growth factors produced from genetic engineering techniques. It has been reported that injection of such a growth factor  
15 into myocardial tissue initiates angiogenesis at that site, which is exhibited by a new dense capillary network within the tissue. Schumacher et al., "Induction of Neo-Angiogenesis in Ischemic Myocardium by Human Growth Factors", *Circulation*, 1998; 97:645-650.

20 Encouraging the initiation of naturally occurring angiogenic mechanisms within tissue such as the release of growth factors during coagulation and fibrin formation would be a desirable method of treating ischemic tissue. It has been recognized that coagulation proteases and regulatory acting during thrombus formation may initiate vascular proliferative responses. Robert S. Schlant (et al.), *The Heart* (1994).

25 Nitric oxide (NO) may prove to be a useful compound in promoting angiogenesis in tissue. M. Ziche, "Nitric Oxide and Angiogenesis", p. 297-306, *Angiogenesis: Models, Modulators, and Clinical Applications*, Maragodakis, Plenum Press, N.Y., 1998. However, nitric oxide compounds can be difficult to deliver nitric oxide effectively to tissue because it is highly volatile and its concentration diminishes  
30 too quickly to be therapeutically effective. U.S. patent no. 5,676,963 (Keefer et al.)

- 4 -

discloses retaining a nitric oxide releasing compound in a polymer matrix that has been applied to an implantable medical device.

It would be desirable to provide angiogenic implant devices for the myocardium that can reliably and controllably release nitric oxide compounds while implanted in myocardial tissue to promote angiogenic activity in that tissue. It also would be desirable to provide a mechanism for joining nitric oxide releasing compounds to a device that does not require use of a polymer matrix on the device.

It is an object of the present invention to provide such a mechanism for controllably administering nitric oxide to promote angiogenic activity.

#### Summary of the Invention

The present invention provides methods for joining nitric oxide (NO) releasing compounds to implantable medical devices. The NO is believed to have an effect on angiogenic activity in tissue. NO may be useful in prohibiting angiogenesis, which is useful in preventing the growth of tumors. However, NO may hold potential in increasing angiogenic activity in tissue. Tissue that would benefit from angiogenic activity may include ischemic regions of the myocardium of the heart. Therefore, angiogenic implants configured to promote angiogenesis in the myocardium of the heart could be more effective if treated to release NO in a controlled fashion while implanted.

The angiogenic implant devices may comprise a flexible helically spring body measuring on the order of approximately 1 to 1 ½ millimeters in diameter and having a length slightly shorter than the thickness of the myocardial wall into which they are to be placed (on the order of 7-9 millimeters). The devices may be made from any material, but preferably materials include: surgical grade stainless steel, nickel-titanium alloys, MP35N, or polymers either permanent or biodegradable. The device may be implanted either percutaneously through a delivery catheter that has been navigated into the left ventricle of the heart and as configured to penetrate the endocardium to deliver to insert the implant. Alternatively, the device may be delivered surgically through the epicardium over a piercing delivery device, or may be delivered transthoracically. The device is not only configured to promote

angiogenesis by triggering an injury response to the tissue at the implant site but also serve as a depot for carrying the nitric oxide releasing compounds and maintaining them in proximity the tissue to be treated. Additionally the devices may carry other angiogenic agents such as growth factors, or may carry cellular compositions useful in  
5 regenerating ischemic tissue.

In a first method, NO releasing compound can be reacted with organosilane to bond the NO releasing compound to the structure of the implantable device. The formula for organosilane shows two classes of functionality ( $R_nX_{(4-n)}$ ). The X group will be involved in the reaction with the substrate of the chosen medical device. R is a  
10 non-hydrolyzable organic radical that possess s functionality, which will enable the coupling agent to bond with the NO releasing compounds.

In another aspect of the invention, NO releasing compound may be associated with a metal medical device material by the following steps. Applying coating of primer onto the metal surface having excess isocyanate groups. Thereafter, exposing  
15 the surface to NO releasing compounds to produce a coating that is capable of releasing NO upon activation.

In another aspect of the invention, nitric oxide is associated with a medical device surface by first, applying silane onto the surface. Next, a graft polymer is created around the surface having excess functional groups such as isocyanate.  
20 Next, the surface is exposed to NO releasing compounds, which will be capable of performing as a medical device coating capable of releasing nitric oxide upon activation.

In another aspect of the invention, NO releasing compounds are held in a hydrophilic polyurethane matrix. In particular the matrix may comprise the hydrophilic  
25 polyurethane material. Alternatively, the polyurethane matrix may be applied to the device and permitted to cure, then submersed in an aqueous solution of the NO to permeate the matrix with the NO releasing compounds. In another embodiment of the method, a hydrophilic polymer is applied to the surface of the device and permitted to cure after which it is exposed to the aqueous solution of NO containing  
30 adduct. The aqueous medium may then be removed by evaporation.

- 6 -

It is an object of the present invention to provide a angiogenic myocardial implant device having associated with it nitric oxide releasing compounds.

It is another object of the present invention to provide a myocardial angiogenic implant device that releases nitric oxide controllably and in therapeutically effective amounts over time to promote angiogenesis in the surrounding tissue.

It is another object of the invention to provide a method to join nitric oxide directly to the surface of a device without the need for a separate matrix to hold the substance to the device.

It is another object of the invention to provide a medical device having a polymer matrix coating containing NO releasing compounds.

#### **Brief Description of the Drawings**

The foregoing and other objects and advantages of the invention will be appreciated more fully from the following further description thereof, with reference to the accompanying diagrammatic drawings wherein:

FIG. 1 is a side view of an embodiment of the tissue implant device;

FIG. 2 is a partial sectional view of the tissue implant device shown in FIG. 1;

FIG. 3 is a partial sectional view of a variation of the tissue implant device shown in FIG. 2;

FIG. 4A. is a side view of a tissue implant device delivery system;

FIG. 4B is a detailed side view of the distal end of the tissue implant device delivery system;

FIG. 4C is a detailed side view of the distal end of the tissue implant device delivery system carrying an implant.

FIGS. 5A-5D are diagrammatic illustrations of an implant device being delivered to the myocardium by a percutaneously inserted delivery catheter;

FIG. 6A is a side view of a delivery device carrying an implant device to a tissue location; and

FIG. 6B is a side view of a delivery device after releasing an implant device to a tissue location.

### Description of the Illustrative Embodiments

The present invention provides for a wide range of myocardial implants having associated with them nitric oxide (NO) releasing compounds to aid in initiating angiogenic activity in the myocardial tissue into which the device is implanted.

5 Angiogenic implants and methods for implanting them are disclosed in pending U.S. Patent Application Serial Numbers 09/073,119 09/164,163, 09/164,884, 09/164,173, 09/521,332, 09/299,795, 60/134,331 and 60/134,106, the entirety of which is incorporated by reference herein.

10 An example of a suitable angiogenic implant device is discussed below with reference to the figures.

FIG. 1 shows an embodiment of a tubular implant device. The canted coil device 40 is formed from a filament 42 of rectangular cross-section such as a strand of flat wire. As shown in FIG. 2, the coil is formed so that the major cross-sectional axis 47 of the rectangular wire is oriented at an acute angle to the longitudinal axis 50 of the coil 40. The orientation gives each turn 46 of the coil a projecting edge 44,  
15 which tends to claw into tissue to serve as an anchoring mechanism for the device.

FIG. 3 shows a segment of a wrapped ribbon implant embodiment. The implant 60 is formed by a filament of a rectangular cross-sectional filament around a ribbed mandrel. In the present embodiment, the major axis 47 of the rectangular cross-section ribbon is oriented substantially perpendicular to the longitudinal axis 50 of the implant, as is shown in FIG. 3. In this configuration, the major axis 47 of the coils 42 of the rectangular ribbon do not extend radially from the longitudinal axis 50 of the implant 40 at an acute angle. With greater coil surface area extending away from the longitudinal axis of the implant, the implant is believed to be more stable and  
20 less likely to migrate once implanted within the myocardium. The implant is preferably formed from 316 stainless steel rectangular cross-section forming wire. Preferred dimensions for the rectangular cross-section filament are on the order of .003 inches to .005 inches for the minor axis width and .015 to .018 inches for the major axis.

25 The implant devices of the present invention may be delivered to their intended tissue location surgically. FIGS. 4A - 4C show an example of a surgical delivery device that may be used to deliver the implants into tissue such as that of the



- 8 -

myocardium of the heart. The delivery device, shown in FIG. 4A, comprises an obturator 80 that includes a main shaft 82, by which it can be gripped and manipulated. The distal end 81 of the shaft 82 is shown in detail in FIG 4B and includes a reduced diameter device support section 84 having a sharp distal tip 86 adapted to pierce tissue. The diameter of the shaft segment 84 is such as to fit closely within the interior of the devices. The proximal end of the segment 84 terminates in a shoulder 88 formed at the junction of a proximally adjacent, slightly enlarged diameter portion 90 of the shaft. The distal end of the device support segment 84 may include a radially projecting pin 92 dimensioned to project and fit between adjacent turns of the coils of a device . The pin 92 engages the coils in a thread-like fashion so that after the assembly has been inserted into the tissue, the obturator 80 can be removed simply by unscrewing the obturator to free it from the implanted coil. Alternatively, the obturator may be configured without the projecting pin 92 so that the device can be slipped on and off the obturator, without screwing.

When an implant device 2 is mounted on the obturator 80, as is shown in FIG. 4C the proximal end of the device may bear against the shoulder 88, and the tail 28, if so equipped may extend along the segment 90 of the obturator.

In use, the intended tissue location is first accessed surgically, such as by a cut-down method. The obturator, with an implant device loaded on to segment 84, then may be advanced into the tissue to deliver the implant. The sharp tip pierces the tissue permitting the obturator and implant to be pushed inward into the tissue. In the example of delivery to the myocardium, the epicardial surface of the heart is accessed and penetrated by the obturator to deliver the implant. The shoulder 88 prevents proximal movement of the implant along segment 84 during delivery. Preferably, the distal end of the obturator is projected to, and slightly beyond, the endocardium to place the implant device. The obturator then may be unscrewed and separated from the implant device. If the obturator is configured without the pin 92, the obturator may be withdrawn directly from the device and the tissue. Simply applying light closure pressure to the epicardial puncture will cause the puncture hole to clot at the epicardium.

- 9 -

The implant devices may, alternatively, be delivered to the myocardium percutaneously through the endocardium. As is shown in FIGS. 5A through 5D, a delivery catheter 136 may be navigated to the left ventricle 122 over a guide wire 134 that has been previously navigated to the ventricle and anchored into the tissue by a barbed distal tip 135. To access the left ventricle of the heart percutaneously, a guide catheter (not shown) may be navigated through the patient's vessels to reach the left ventricle 122 of the heart 120. A barbed tip guidewire 134 may then be inserted through the guide catheter and into the ventricle where it pierces the myocardium 124 and becomes anchored within the tissue. After anchoring the guidewire, the steerable delivery catheter 136 may be advanced over the guidewire to become positioned within the ventricle in close proximity to the endocardium 126 to facilitate delivery of implant devices 40. To facilitate delivery of multiple devices, the guidewire lumen of the delivery catheter 136 may be eccentrically located on the catheter. Therefore, when the catheter is rotated about the guidewire, the center of the catheter will rotate through a circular path as demonstrated in FIGS. 5C and 5D, to encompass a broader delivery area with only a single guidewire placement. The outside diameter of the delivery catheter is preferably less than .100 inch. Additionally, the delivery catheter may be provided with steering capability by means of a pull wire extending the length of the catheter and attached at its distal end such that pulling on the wire from the proximal end causes the distal tip of the catheter to be deflected. The steering capability provides a broader range of delivery area with a single catheterization. A description of the construction of a delivery catheter for reaching multiple sites within the left ventricle is described in U.S. patent application serial no. 09/073,118 filed May 5, 1998, the entire disclosure of which is herein incorporated by reference.

FIGS. 6A and 6B show a side view of a preferred delivery device 140 for the tubular implants 40. The delivery device 140 shown in FIG. 6A may be used with a conventional guide catheter or the steerable catheter 136 discussed above. The delivery device 140 comprises an outer push tube 156 and an independently slidable elongate inner shaft 142 having a sharp obturator head 146 at its distal end. The obturator head 146 is formed at the distal end of the inner shaft 142 by any convenient means and is configured to have a sharp, piercing tip 148. Included in the

- 10 -

material that forms the obturator head 146 should be a radiopaque material such as gold or platinum to make the distal area of the device visible under fluoroscopy. Heat bonded to the proximal end 150 of the obturator head 146 is a flexible crinkle tube 152, which may be formed from a material such as polyethylene terephthalate (PET).  
5 Attached to the proximal end 154 of the crinkle tube 152 by heat bonding is the push tube 156, which may be formed from a closely wound spring having a PET shrink tube formed around its outer surface to fill in the voids created by the coils. The crinkle tube 152 collapses under compressive load to form a random pattern of folds 158, which serve to increase the overall diameter of the crinkle tube 152 such that it comes  
10 into engagement and frictional contact with the interior surface of a hollow or generally tubular implant device 40 placed over it.

When placed in tension as shown in FIG. 6B, the crinkle tube elongates and returns to a low diameter configuration without folds. The configuration of the crinkle tube is manipulated by relative movement of the inner shaft 142, having its obturator  
15 146 joined to the distal end 155 of the crinkle tube, relative to the push tube 156, which is joined to the proximal end of the crinkle tube 154. The inner shaft and push tube are slidable relative to each other and may be made controllable from the proximal end of the device by a suitable handle and core wire extension.

To deliver an implant device 40 to a tissue location, the device first must be  
20 loaded over the crinkle tube. The push tube is moved in a distal direction and the core wire is moved in the proximal direction to compress the crinkle tube 152 effectively increasing the diameter of the crinkle tube. The increased diameter crinkle tube engages the interior chamber 6 of an implant device 40, holding it in place for delivery into tissue as shown in FIG. 6A. After being navigated to the intended  
25 location within a guide catheter, the distal end of delivery device is then advanced distally out of the guide catheter so that the sharp tip 148 penetrates into the tissue 124 and the device 40 becomes implanted. As shown in FIG. 6B, after delivery into tissue, the crinkle tube may be placed in tension, to withdraw the plurality of folds that engage the interior chamber of the implant 40. After reducing the profile of the crinkle  
30 tube 152 the implant device 40 easily slides off the crinkle tube over the obturator 146 and remains in place in the tissue 124. The delivery device is then withdrawn from

the tissue. Below are described methods for associating the NO compounds with those devices.

In one aspect of the invention, an NO releasing compound is adhered to a device surface directly, without requiring a polymer matrix coating first be applied to the device to hold the compounds. The NO releasing compound is reacted with organosilane in a solution. The reaction product is silane-NO releasing compound adduct. The adduct can then be coated on a medical device such as a myocardial implant by subjecting the X group to hydrolysis. After hydrolysis, a reactive silanol group is formed that reacts with the surface of the device to form a covalent bond. Alternatively, the organosilane first may be applied onto the device surface followed by a reaction with NO releasing compound. Alternatively, a film-forming material may be added to the formulation for coating

#### Example 1

The following example illustrates the method. A nitric oxide for nucleophile complex, i.e.,  $((\text{CH}_3)_2\text{CHNH}[\text{N}(\text{O})\text{NO}]\text{Na}) \cdot ((\text{CH}_3)_2\text{CHNH})$  as in nucleophile residue of a primary amine that can react with silane containing isocyanate functionality (e.g., example 3-isocyanatopropyltriethoxysilane). The method provides a primer for medical device materials that may not have enough free OH (oxidation) on their surface to bond the molecules. The resulting adduct(?) still contains NO releasing functional group ( $\text{N}_2\text{O}_2$ ) with added ability to bind to substrate of a medical device the surface of a medical device. The surface could be metal or ceramic or plastic.

In an alternate embodiment of joining NO compounds to a medical device, NO releasing compounds are retained in a hydrophilic polyurethane matrix associated with the device. The matrix can be formed from an isocyanate terminal adduct reacted with a polyol, amine or other moiety that can react with an isocyanate, and adding a polyethylene oxide in the presence of a carrier organic solvent. The NO releasing adduct will be soluble in the carrier organic solvent and is added to the coating mix. In this method, a primer may be employed to insure a surface is present with which the polyurethane matrix may react in bond.

- 12 -

In a method similar to the above disclosed method, a polyurethane matrix is formed from an isocyanate terminal adduct (pre-polymer) reacted with a polyol, amine or other moiety that can react with an isocyanate and a polyethylene oxide in the presence of a media. After the hydrophilic polyurethane is cured onto the device  
5 surface, the device is put into an aqueous solution of the NO releasing adduct. The hydrophilic substance will absorb the aqueous solution of the NO containing adduct. The aqueous media is then removed by evaporation which can be assisted by a vacuum. In this method, a primer may be employed to insure a surface is present for the polyurethane matrix to become bonded.

10 A hydrophilic polymer or a hydrogel could be attached to the surface. In the case of NO releasing adduct being soluble in the carrier organic solvent, it is added to the coating mix. In case of the NO releasing adduct being soluble in an aqueous media, after the hydrophilic or hydrogel is attached to the catheter, the hydrophilic substrate will absorb the aqueous solution of the NO containing adduct. The aqueous  
15 media is then removed by evaporation which can be assisted by vacuum. In this method, a primer may be employed to insure a surface to which the polyurethane matrix may react and bond is present.

From the foregoing it will be appreciated that the invention provides particularly effective angiogenic implants, useful in tissue such as ischemic myocardial tissue,  
20 that combines an device and NO releasing compounds joined to the device. Additionally an effective method for joining NO releasing compounds directly to a device without requiring that a polymer matrix first be applied to the device to hold the NO is provided.

It should be understood however, that the foregoing description of the invention  
25 is intended merely to be illustrative thereof and that other modifications, embodiments and equivalents may be apparent to those who are skilled in the art without departing from its spirit. Having thus described the invention what we desire to claim and secure by letters patent is:

30

**CLAIMS**

- 1           1.     An angiogenic implant comprising:  
2                 a body configured to be implanted within myocardial tissue;  
3                 a nitric oxide releasing compound associated with the body so as to be  
4                 released from the device into surrounding tissue over a therapeutically effective  
5                 period of time to promote angiogenesis in the tissue.
  
- 1           2.     An angiogenic implant as defined in claim 1 wherein the body comprises  
2                 a flexible coil.
  
- 1           3.     An angiogenic implant as defined in claim 1 wherein the nitric oxide  
2                 releasing compound is bonded directly to a surface of the device.
  
- 1           4.     An angiogenic implant as defined in claim 3 wherein the nitric oxide  
2                 releasing compound is reacted with organosilane to become associated with  
3                 the surface of the device by covalent bonding.
  
- 1           5.     An angiogenic implant as defined in claim 1 wherein the nitric oxide  
2                 releasing compound is associated with a surface of the body by a polymer  
3                 matrix coating.
  
- 1           6.     A method of promoting angionesis within the myocardium of the heart  
2                 comprising:  
3                 providing at least one angiogenic implant comprising a body having  
4                 associated with it a nitric oxide releasing compound;  
5                 implanting the at least one body in the myocardium such that the nitric  
6                 oxide is released from the body to the surrounding tissue in a controlled  
7                 manner.

- 14 -

1           7.     A method of promoting angiogenesis as defined in claim 6 wherein the  
2           angiogenic implant is implanted into the myocardium surgically through the  
3           epicardium of the heart.

1           8.     A method as defined in claim 6 wherein the angiogenic implant is  
2           implanted in the myocardium percutaneously through the endocardium.

1           9.     A method of promoting angiogenesis as defined in claim 6 wherein the  
2           nitric oxide releasing compound is joined directly to the body of the device by  
3           covalent bonding created by the presence of organosilane.

1           10.    A method of joining a nitric oxide releasing compound to a medical  
2           device comprising:  
3                    reacting a nitric oxide releasing compound with organosilane to bond the  
4           nitric oxide releasing compound to a surface of the device.

1           11.    A method as defined in claim 10 wherein the organosilane and nitric  
2           oxide releasing compound are reacted together on a surface of the device to  
3           promote bonding of the nitric oxide releasing compound to the device.

1           12.    A method as defined in claim 10 wherein the organosilane is first applied  
2           to a surface of the device and dried; and  
3                    secondly, a nitric oxide releasing compound is applied to a device and  
4           dried.

1           13     A method as defined in claim 10 wherein a primer coating to provide  
2           free hydroxide on a surface of the device is first applied to the device prior to  
3           application of the nitric oxide releasing compound and organosilane.

1/4

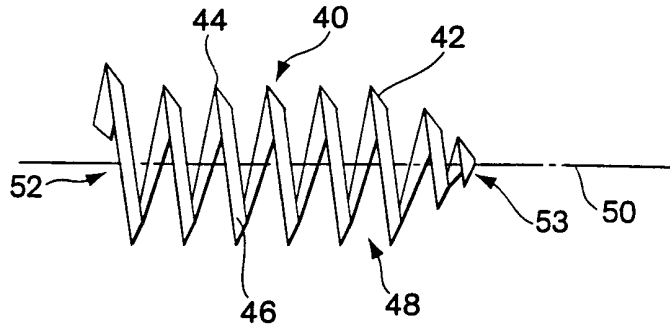

Fig. 1

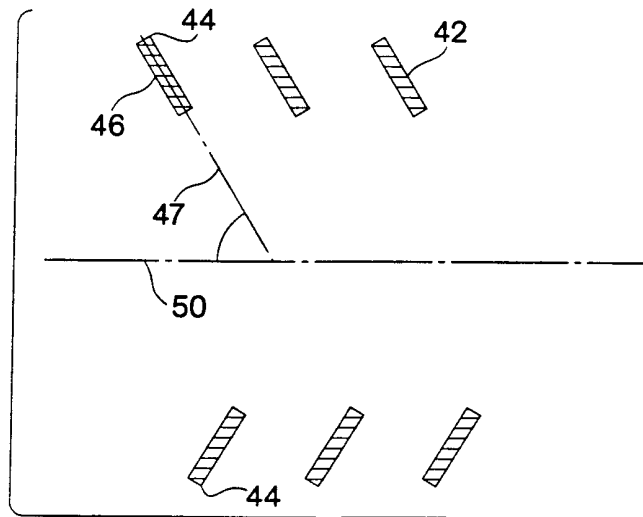

Fig. 2

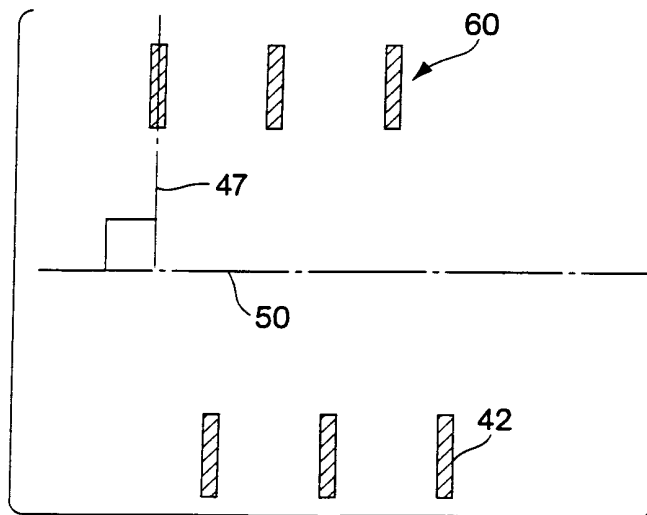
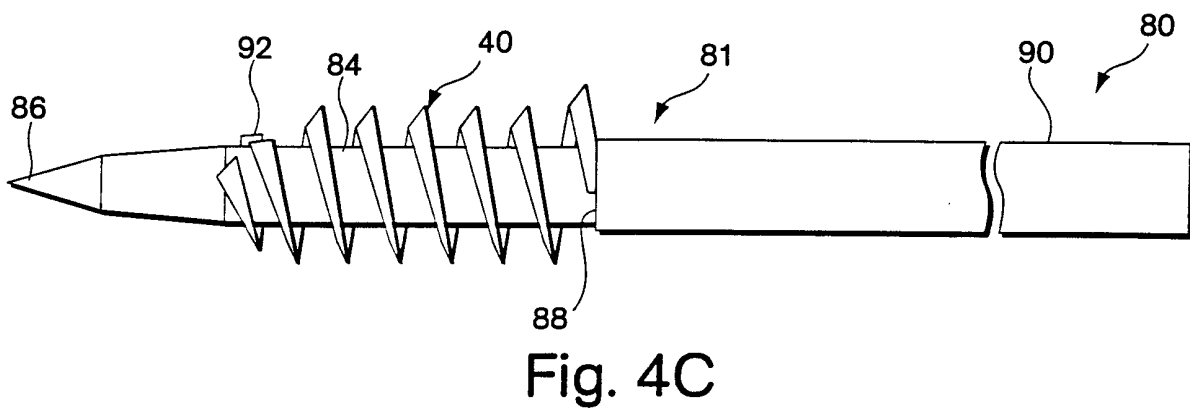
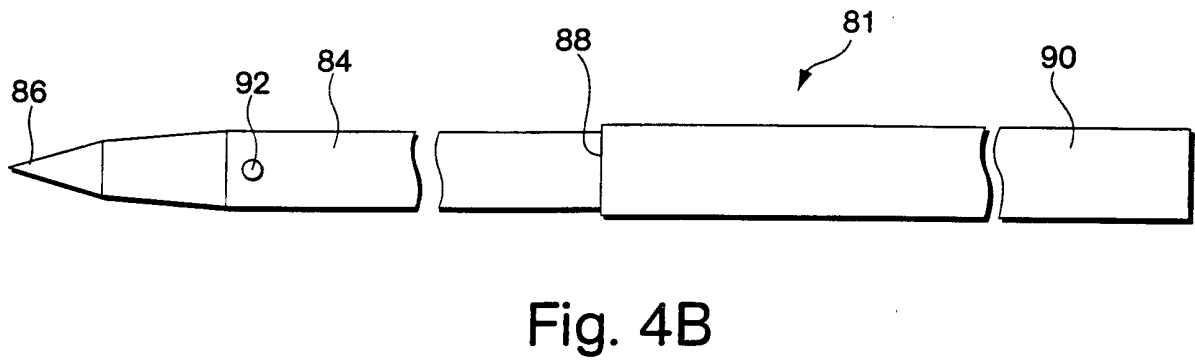
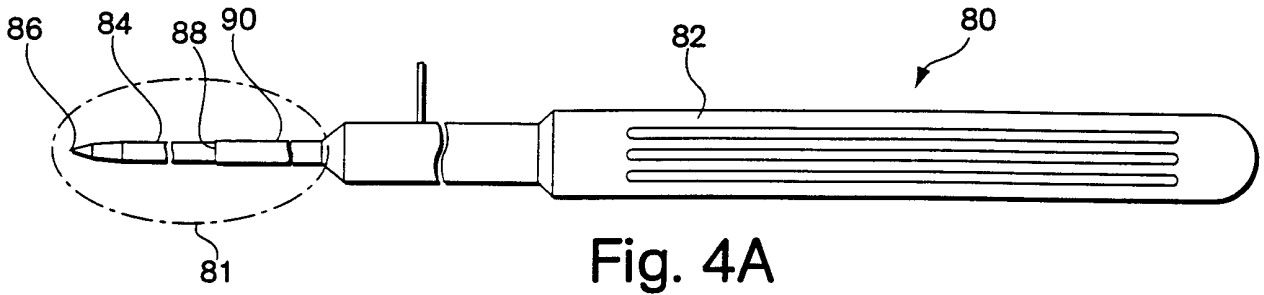

Fig. 3



2/4



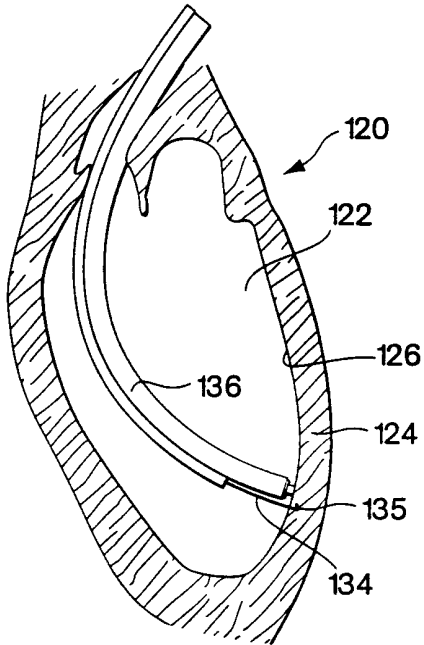

Fig. 5A

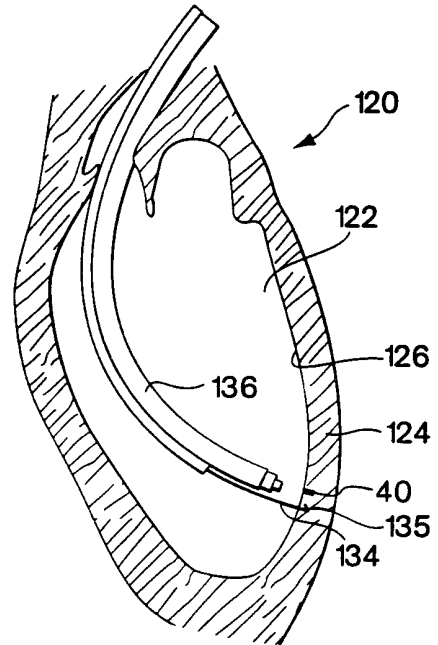

Fig. 5B

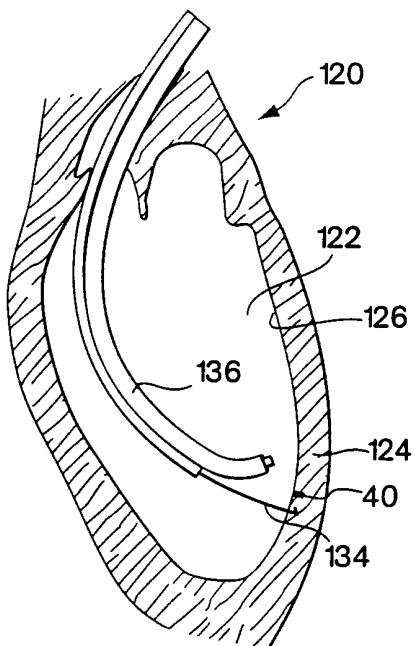

Fig. 5C

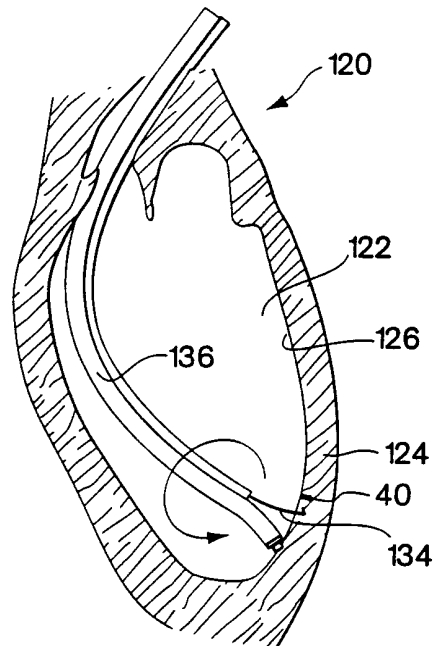
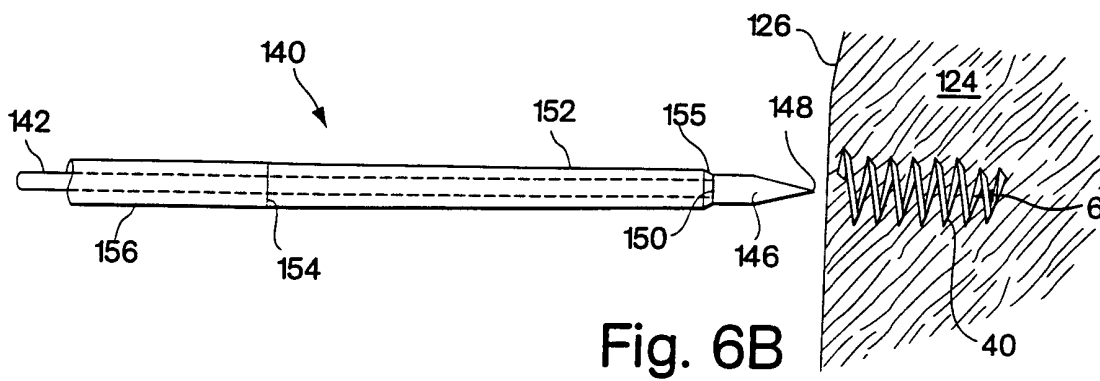
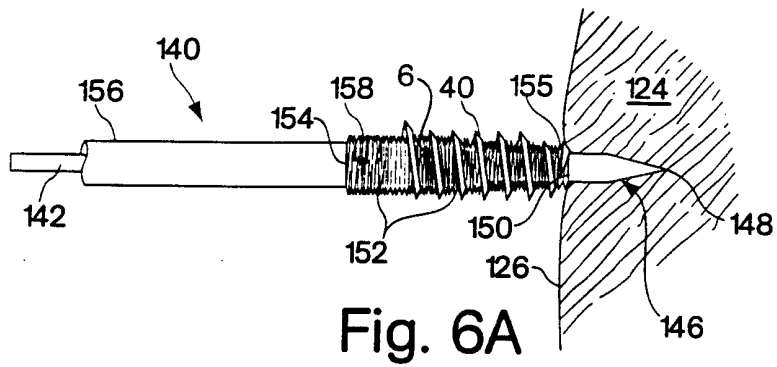

Fig. 5D



INTERNATIONAL SEARCH REPORT

International application No.  
PCT/US00/20566

A. CLASSIFICATION OF SUBJECT MATTER

IPC(7) :A61F 2/02; A61K 9/52, 31/215; A61M 31/00, 5/32; C08K 3/28  
US CL :128/898; 524/429; 604/52, 266; 623/1.22, 1.42, 901

According to International Patent Classification (IPC) or to both national classification and IPC

B. FIELDS SEARCHED

Minimum documentation searched (classification system followed by classification symbols)

U.S. : 128/898; 524/429; 604/52, 266; 623/1.22, 1.42, 901

Documentation searched other than minimum documentation to the extent that such documents are included in the fields searched

Electronic data base consulted during the international search (name of data base and, where practicable, search terms used)

WEST 2.0

C. DOCUMENTS CONSIDERED TO BE RELEVANT

Category*	Citation of document, with indication, where appropriate, of the relevant passages	Relevant to claim No.
X --- Y	US 5,900,433 A (IGO et al.) 04 May 1999, col. 9 lines 42-47, col. 10 lines 39-65, col. 11 lines 1-7, and col. 13 lines 56-63	1-3, 6-8 ----- 4, 5, 9-13
Y,P	US 5,994,444 A (TRESCONY et al.) 30 November 1999, col. 4 lines 17-21, col. 5 lines 10 and 11, col. 6 lines 6-9, col. 10 lines 3-23.	3, 5
Y	US 5,356,433 A (ROWLAND et al.) 18 October 1994, col. 4 lines 40-68, col. 5 lines 22-40, and col. 6 Example 1.	2, 4, 9-13
Y	US 5,665,077 A (ROSEN et al.) 09 September 1997, col. 3 lines 51-64, col. 4 lines 40-46, and col. 6 lines 29-38.	3, 5

Further documents are listed in the continuation of Box C.  See patent family annex.

* Special categories of cited documents:	*T* later document published after the international filing date or priority date and not in conflict with the application but cited to understand the principle or theory underlying the invention
*A* document defining the general state of the art which is not considered to be of particular relevance	*X* document of particular relevance; the claimed invention cannot be considered novel or cannot be considered to involve an inventive step when the document is taken alone
*E* earlier document published on or after the international filing date	*Y* document of particular relevance; the claimed invention cannot be considered to involve an inventive step when the document is combined with one or more other such documents, such combination being obvious to a person skilled in the art
*L* document which may throw doubts on priority claim(s) or which is cited to establish the publication date of another citation or other special reason (as specified)	*G* document member of the same patent family
*O* document referring to an oral disclosure, use, exhibition or other means	
*P* document published prior to the international filing date but later than the priority date claimed	

Date of the actual completion of the international search

19 SEPTEMBER 2000

Date of mailing of the international search report

17 OCT 2000

Name and mailing address of the ISA/US  
Commissioner of Patents and Trademarks  
Box PCT  
Washington, D.C. 20231

Facsimile No. (703) 305-3230

Authorized officer

CHOON P. KOH

Telephone No. (703) 305-1232