

H. H. LINDEMUTH.

VALVE.

APPLICATION FILED NOV. 26, 1910.

999,809.

Patented Aug. 8, 1911.

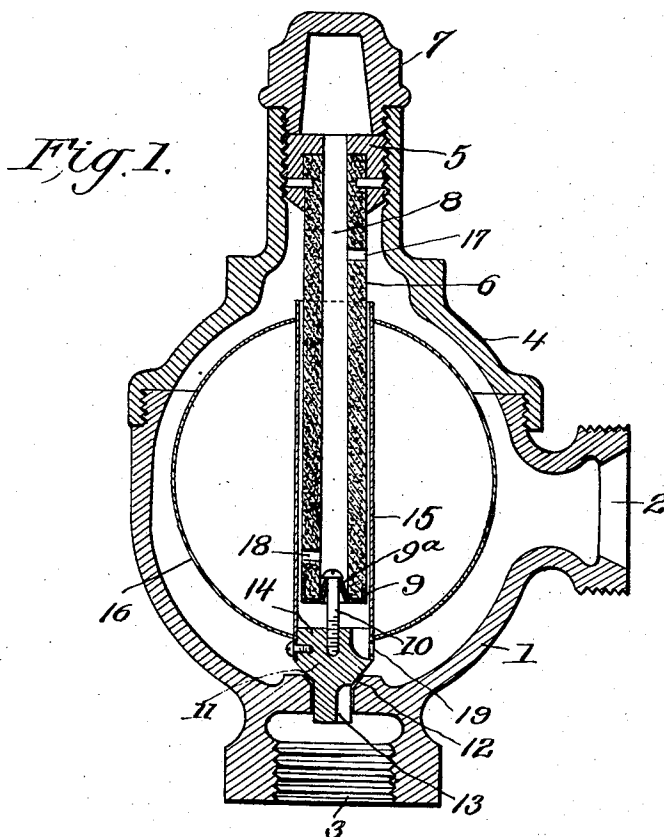

Fig. 2.

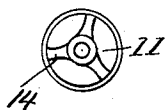
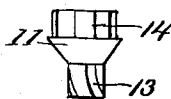

Fig. 3.



Witnesses

W. A. Woodson

J. M. Fallon

Inventor
H. H. Lindemuth

By

H. A. Tracy

Attorneys.

UNITED STATES PATENT OFFICE.

HENRY H. LINDEMUTH, OF YORK, PENNSYLVANIA.

VALVE.

999,809.

Specification of Letters Patent. Patented Aug. 8, 1911.

Application filed November 26, 1910. Serial No. 594,367.

To all whom it may concern:

Be it known that I, HENRY H. LINDEMUTH, citizen of the United States, residing at York, in the county of York and State of Pennsylvania, have invented certain new and useful Improvements in Valves, of which the following is a specification.

This invention comprehends certain new and useful improvements in that class of valves that operate on the thermostatic principle and that are used particularly as vent valves for radiators of steam heating systems, although it is to be understood that my invention, hereinafter called a trap, is applicable for use generally, not only in connection with the radiators of hot water or steam heating systems, but wherever it is desired to exhaust the air from a radiator, boiler, or the like, so as to obtain the full or maximum efficiency of the steam.

The invention has for its primary object a simple, durable and efficient construction of steam trap of this character, the parts of which are so arranged that the single valve employed will be positively moved off of its seat when the radiator, for instance, is cold, which will move onto its seat when the radiator or the like becomes sufficiently warm, but which will at the same time permit the valve, when the parts are heated, to rise from its seat by buoyant action, so as to discharge the products of condensation, not only when the device is cold, but when it is in its normally warm or hot condition. And the invention has for a further object to generally improve this class of devices and to render them more efficient and satisfactory in use and more commercially desirable.

With these and other objects in view as will more fully appear as the description proceeds, the invention consists, essentially, in a hydrostatic steam trap and air valve embodying an expansion post, a valve designed when moved from its seat to permit the air and products of condensation to escape, and such a connection between the expansion post and valve that the latter will be positively moved from its seat when the expansion post is relatively cold, but will be permitted to rest on its seat when the expansion post is relatively hot, while at the same time, the valve may, in the latter condition of the expansion post, move from its seat so as to discharge the water automatically, when necessary.

And the invention also consists in a device of the type specified in the preceding paragraph, which embodies a single valve and valve seat which will perform all of the functions hereinafter mentioned, in connection with a post or rod acting on the thermostatic principle. And the invention consists in certain constructions, arrangements and combinations of the parts that I shall hereinafter fully describe and claim.

For a full understanding of the invention, reference is to be had to the following description and accompanying drawings, in which:

Figure 1 is a vertical longitudinal sectional view of a trap embodying the improvements of my invention; Fig. 2 is a detail top plan view of the valve employed; and, Fig. 3 is a detail side view thereof.

Corresponding and like parts are referred to in the following description and indicated in all the views of the drawings by the same reference characters.

Referring to the drawing, the numeral 1 designates the body portion of my improved trap, the same being formed with an inlet 2 and discharge or outlet opening 3 arranged in the usual manner for attachment to or incorporation in a steam heating system embodying the ordinary radiators. In the present embodiment of the invention, the body portion 1 is provided with a detachable bonnet 4, the neck of which is interiorly screw threaded to receive the adjustment plug 5 to which a thermostatic member in the form of an expansion post 6 is connected, as by pins or similar fastening devices.

7 designates the ordinary cap, closing the upper end of the bonnet.

The expansion post 6 is formed with a longitudinal bore extending therethrough from end to end and constituting an equalizing duct 8, and secured to the lower end of the expansion post is a collar 9, the same being secured to the post in any desired way, as by being pressed into the post and frictionally held thereon, and being formed with any desired number of centrally disposed upwardly projecting lugs 9^a, said lugs extending into the lower end of the duct 8 and engaging the head of a suspension pin 10. This pin is secured in any desired way to a valve 11, the pin in the present instance being screw threaded at its lower end for engagement in a correspondingly formed

socket formed in the top of the valve. The valve 11 is adapted to rest upon a preferably beveled seat 12 which is formed in the body 1, said seat establishing communication between the inlet opening 2 and the outlet opening 3, and being controlled by the single valve 11 for the passage of both air and water. Preferably, the valve 11 is formed with spirally disposed discharge ports 13 formed in its downwardly projecting stem or nib, whereby as the water passes the valve, it will have a tendency to turn the same about its longitudinal axis, whereby the valve will rub on the seat 12 and tend to keep the same clear of any accumulations which might otherwise interfere with the proper closing movement of the valve. The valve 11 is formed with any desired number of ribs 14, the same being three in number in the present instance and alternating with the spiral valve ports 13, and screws or similar fastening members extend into these ribs and through the downwardly projecting end of a tube 15 which constitutes the open ended diametrically disposed and vertically positioned member of a substantially spherical float 16, brazed or otherwise secured to the tube.

In the preferred construction of the parts, the expansion post 6 is formed, above the upper end of the tube 15, with a vent 17 and the post is further formed, near its lower end and within the tube 15, with a drain 18. The spaces between the ribs 14 of the valve 11 establish communication between the interior of the tube 15 and the interior of the body 1 exterior of said tube, by ports 19 formed in the downwardly projecting end of the tube 15, so as to constitute drain openings.

From the foregoing description in connection with the accompanying drawing, the operation of my improved trap will be apparent. In the practical use of the device, when the radiator for instance is cold, the contraction of the expansion post 6 will result in the lifting of the valve 11 from the valve seat 12, through the instrumentality of the suspension pin 10 that is connected with the valve and that is engaged by the upwardly projecting lugs 9^a of the collar 9 that is fastened to the lower end of the expansion post. Hence, so long as the parts are relatively cool, the air may be vented from the radiator or the other part to which the device is attached; but when the parts become warm, the expansion of the post 6 and the consequent elongation thereof, will permit the valve 11 to close automatically on its seat, while at the same time so long as the post 6 is expanded, the valve 11 will be permitted to have a limited movement toward the open position independent of any movement or contraction of the post 6 and consequently the products of condensation

may, by their buoyant action upon the float 16, raise the valve 11 from its seat and pass off.

It will be noted that in my invention, the expansion post or member has only the functions of expanding and contracting and does not serve as a valve or valve seat, the device thereby possessing distinct advantages over valves in which the expansion member constitutes a valve or valve seat also, in that such devices are open to the objection that when they are adjusted to a certain or predetermined pressure for their expansion effect, and such pressure is exceeded, the expansion post or member is liable to excessive expansion, resulting in crushing the post after it has come into contact with the valve seat, for instance.

It is to be understood that my invention is not limited to any specific construction, arrangement or proportions of the parts, as various changes may be made in the structure of the device, without departing from the scope of the invention as defined in the appended claims.

Having thus described the invention, what is claimed as new is:

1. A trap of the character described, provided with a valve seat, and embodying a thermostatic member, a valve adapted to rest on said seat, and a connection between the thermostatic member and valve, permitting the valve to have a limited movement away from its seat in the expanded condition of the thermostatic member and positively moving the valve from the seat when the thermostatic member contracts, and means for moving the valve away from its seat in the expanded condition of the thermostatic member.

2. A trap of the character described, provided with a valve seat, and embodying a float actuated valve and a thermostatic member, and a connection between the two permitting a movement of the valve away from its seat independently of the thermostatic member in the expanded condition of the latter, and positively moving the valve from its seat when the thermostatic member contracts.

3. A trap of the character described, provided with a valve seat and embodying a thermostatic member, a valve adapted to be suspended from the thermostatic member in the contracted condition of the latter with the valve removed from its seat, the valve being movable in a direction away from its seat independently of the thermostatic member, and means other than the thermostatic member for moving the valve away from its seat in the expanded condition of the thermostatic member.

4. A trap of the character described, provided with a valve seat and embodying a thermostatic member, a valve adapted to

be suspended from the thermostatic member in the contracted condition of the latter with the valve removed from its seat, the valve being movable in a direction away from its seat independently of the thermostatic member, and a float connected to said valve.

5. A trap of the character described, provided with a valve seat and embodying a thermostatic member, a valve adapted to be suspended from the thermostatic member in the contracted condition of the latter with the valve removed from its seat, the valve being movable in a direction away from its seat independently of the thermostatic member, and a float connected to said valve, the float having a guiding movement on the thermostatic member.

6. A trap of the character described, provided with a valve seat and embodying a valve adapted to rest on said seat and provided with a suspension pin, a thermostatic member also embodied in the trap, a connection between said thermostatic member and the pin, permitting a movement of the pin into the thermostatic member and limiting the outward movement of the pin from the thermostatic member, and a float connected to said valve.

7. A trap of the character described, provided with a valve seat, and embodying a valve adapted to rest on said seat, a thermostatic member also embodied in the trap and formed with an equalizing duct, a suspension pin secured to the valve and movable into said duct, the thermostatic member being provided with means preventing the complete extraction of the pin from the duct, and a float connected to said valve.

8. A trap of the character described, provided with a valve seat and embodying a valve adapted to rest on said seat, a thermostatic member also embodied in the trap and provided with an equalizing duct, a collar secured to said thermostatic member and provided with a lug projecting into the duct, a headed pin secured to the valve and extending into the duct and engaged by said lug, and a float connected to said valve.

9. A trap of the character described, provided with a valve seat and embodying a valve adapted to rest on said seat, a thermostatic member also embodied in the trap and provided with an equalizing duct, a suspension pin secured to the valve and extending into the duct, a collar secured to the lower end of the thermostatic member and formed with a lug projecting upwardly into the duct and engaging the pin to limit the outward movement of the pin from the duct, and a float connected to said valve.

10. A trap of the character described, provided with a valve seat and embodying a valve adapted to rest on said seat, an expansion post also embodied in the trap and provided with an equalizing duct, a suspen-

sion pin secured to the valve and extending into the duct, a collar secured to the lower end of the post and formed with a lug projecting upwardly into the duct and engaging the pin to limit the outward movement of the pin from the duct, and a float connected to said valve, said float embodying a diametrically disposed tube surrounding the post and movable thereon.

11. A trap of the character described, provided with a valve seat and embodying a valve adapted to rest on said seat, an expansion post also embodied in the trap and provided with an equalizing duct and vent and drain openings extending into the duct, a float connected to the valve, the valve being provided with a drain opening extending through the float so as to establish communication between the equalizing duct and the interior of the trap exterior of the float, and a connection between the expansion post and the valve, permitting an independent movement of the valve irrespective of the expansion of the post.

12. A trap of the character described, provided with a valve seat and embodying a valve adapted to rest on said seat, the valve being formed with a spirally disposed port, a float connected to said valve, a thermostatic member embodied in the trap, and a connection between said thermostatic member and valve, permitting a free rotative movement of the valve independently of the thermostatic member.

13. A trap of the character described, provided with a valve seat and embodying a valve adapted to rest on said seat, the valve being formed with a spirally disposed port, a float connected to said valve, a thermostatic member embodied in the trap, and a connection between said thermostatic member and valve, permitting a free rotative and opening movement of the valve independently of the thermostatic member.

14. A trap of the character described, provided with an inlet opening, an outlet opening, and a valve seat establishing communication between said openings, a valve adapted to rest on said seat, a suspension pin provided at its upper end with a head and connected at its lower end to the valve, a collar provided with a plurality of lugs adapted to extend under the head, while permitting the pin to move in one direction, an expansion post secured in the trap and formed with a longitudinal opening into which the lugs and headed pin project, the collar being secured to one end of said post, and a float provided with a diametrically disposed tube surrounding the post and connected to the valve and movable on the post.

15. A trap of the character described, provided with a valve seat and embodying a valve adapted to rest on said seat, a float connected to said valve, a thermostatic mem-

ber embodied in the trap, and a connection between said thermostatic member and valve, permitting a free rotative and opening movement of the valve independently of the
5 thermostatic member.

16. A trap of the character described, provided with a valve seat and embodying a thermostatic member, a valve adapted to rest on said seat, and a connection between the
10 thermostatic member and the valve, permitting the valve to have a rotative movement

and a movement away from its seat in the expanded condition of the thermostatic member and independently thereof and positively moving the valve from the seat when the
15 thermostatic member contracts.

In testimony whereof, I affix my signature in presence of two witnesses.

HENRY H. LINDEMUTH. [L. s.]

Witnesses:

W. N. WOODSON,
FREDERICK S. STITT.
