



INTERNATIONAL APPLICATION PUBLISHED UNDER THE PATENT COOPERATION TREATY (PCT)

<p>(51) International Patent Classification ⁵ : A61M 39/00</p>	<p>A1</p>	<p>(11) International Publication Number: WO 93/11828 (43) International Publication Date: 24 June 1993 (24.06.93)</p>
<p>(21) International Application Number: PCT/US92/10367 (22) International Filing Date: 1 December 1992 (01.12.92) (30) Priority data: 813,073 18 December 1991 (18.12.91) US (60) Parent Application or Grant (63) Related by Continuation US 813,073 (CIP) Filed on 18 December 1991 (18.12.91) (71) Applicant (for all designated States except US): ICU MEDICAL, INC. [US/US]; 142 Technology Drive, Irvine, CA 92718 (US).</p>	<p>(72) Inventor; and (75) Inventor/Applicant (for US only): LOPEZ, George, A. [US/US]; 14 Sandbar, Corona del Mar, CA 92625 (US). (74) Agents: ALTMAN, Daniel, E. et al.; Knobbe, Martens, Olson & Bear, 620 Newport Center Drive, Suite 1600, Newport Beach, CA 92660 (US). (81) Designated States: AT, AU, BB, BG, BR, CA, CH, CS, DE, DK, ES, FI, GB, HU, JP, KP, KR, LK, LU, MG, MN, MW, NL, NO, NZ, PL, RO, RU, SD, SE, UA, US, European patent (AT, BE, CH, DE, DK, ES, FR, GB, GR, IE, IT, LU, MC, NL, PT, SE), OAPI patent (BF, BJ, CF, CG, CI, CM, GA, GN, ML, MR, SN, TD, TG). Published <i>With international search report.</i></p>	

(54) Title: MEDICAL VALVE

(57) Abstract

A closed system, needleless valve device includes a generally tubular body (20) defining an internal cavity. On the proximal end of the body there is an opening (25A) which is preferably sufficiently large to receive an ANSI standard tip of a medical implement. The distal end of the body has a generally tubular skirt (16). The valve also includes a hollow spike (24) having a closed tip. The spike includes at least one longitudinal 18-gauge hole (34) located distal the tip, and is seated inside the cavity such that the tip is below the proximal end of the body. An annular support cuff (28) is connected to the spike which seals off a portion of the cavity of the body such that an upper cavity containing the tip is defined. The valve also includes a plastic, resilient silicone seal (36) which fills the upper cavity and opening and covers the tip of the spike so as to present a flush surface. An adaptor enables the valve to be attached to a resealable container.

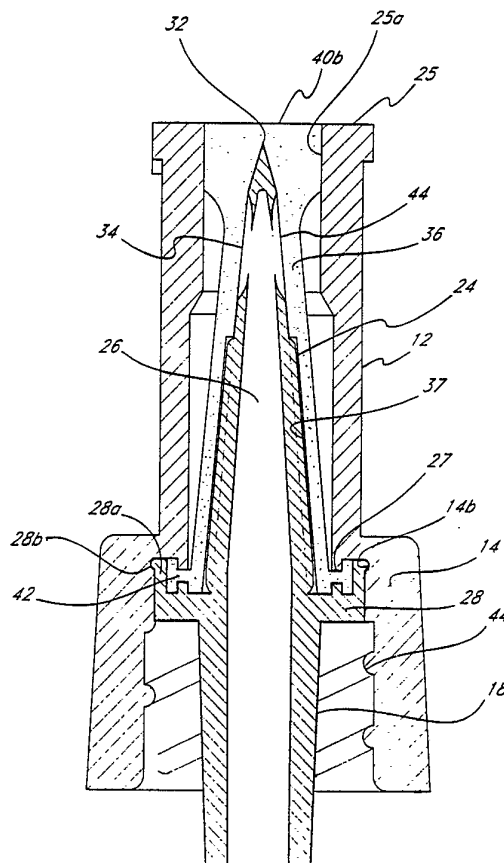

FOR THE PURPOSES OF INFORMATION ONLY

Codes used to identify States party to the PCT on the front pages of pamphlets publishing international applications under the PCT.

AT	Austria	FR	France	MR	Mauritania
AU	Australia	GA	Gabon	MW	Malawi
BB	Barbados	GB	United Kingdom	NL	Netherlands
BE	Belgium	GN	Guinea	NO	Norway
BF	Burkina Faso	GR	Greece	NZ	New Zealand
BG	Bulgaria	HU	Hungary	PL	Poland
BJ	Benin	IE	Ireland	PT	Portugal
BR	Brazil	IT	Italy	RO	Romania
CA	Canada	JP	Japan	RU	Russian Federation
CF	Central African Republic	KP	Democratic People's Republic of Korea	SD	Sudan
CG	Congo	KR	Republic of Korea	SE	Sweden
CH	Switzerland	KZ	Kazakhstan	SK	Slovak Republic
CI	Côte d'Ivoire	LJ	Liechtenstein	SN	Senegal
CM	Cameroon	LK	Sri Lanka	SU	Soviet Union
CS	Czechoslovakia	LU	Luxembourg	TD	Chad
CZ	Czech Republic	MC	Monaco	TG	Togo
DE	Germany	MG	Madagascar	UA	Ukraine
DK	Denmark	ML	Mali	US	United States of America
ES	Spain	MN	Mongolia	VN	Viet Nam
FI	Finland				

-1-

MEDICAL VALVE.

Background of the InventionField of The Invention

5 This invention relates to a closed, patient access system which automatically reseals after administering medication using a standard medical implement that directly connects with the system without the need of any intermediary needles, caps or adaptors. A two-way valve eliminating dead space is used which includes a seal which, upon being compressed by the medical implement, is pierced to open the valve and reseals upon being decompressed, maintaining a fluid tight seal even at high pressures
10 and after repeated uses.

Background Discussion

15 The manipulation of fluids for parenteral administration in hospital and medical settings routinely involves the use of connectors and adaptors for facilitating the movement of fluids between two points. Most fluid connectors and adaptors employ needles to pierce a septum covering sterile tubing or to pierce the septum of a medicament container of fluid. Fluid then passes from the container or fluid filled tubing into a syringe or second set of tubing. These connectors and adaptors often have mechanical or moving parts. Since the ready passage of fluids through the connectors and adaptors is often critical to patient survival, it is imperative that the connectors and adaptors function reliably and repeatedly. Adaptors and connectors that malfunction during use may be life-threatening. The more mechanical or moving parts such as springs and diaphragms, the more likely that they will function improperly. Improper functioning can result in the introduction of air embolisms into a patient. Thus, the fewer the mechanical parts, the more these connectors can be relied on and the better they will
20 be accepted by the medical community.

25 Many connectors or valves, especially those employing several mechanical components, have a relatively high volume of fluid space within them. This "dead space" within the device prevents accurate introduction of precise fluid volumes and provides an opportunity for contamination upon disconnection of the device. Connectors and adaptors often include valves that permit or interrupt the flow of fluid along the course of fluid travel. Several of those commonly in use employ metal needles to puncture sterile seals. Such connectors are generally designed to accommodate fluid flow in one direction. This means that the fluid line must have connectors and tube aligned in complementary directions. These connectors often require further manipulation if, for
30

-2-

example, the valve is inadvertently assembled in a direction that will not facilitate fluid flow. These manipulations increase handling, thereby increasing both the risk of contamination and the amount of time required to establish the fluid connection.

5 Metal needles employed as part of connector devices increase the risk of puncture wounds to the user. The needles used in these devices often have through-holes placed at the tip of the needle. Connection of the valve with a flow line involves piercing the needle through a sealed septum. Through-holes placed at the needle tip can core the septum and release free particulates into the flow line. Such an event can prove fatal to a patient. Such through-holes may also become clogged easily with material from the
10 septum.

Reusable connectors and adaptors are preferred for medical applications since components must often be added or removed from a fluid line connected to a patient. Reusable connectors, however, are difficult to keep sterile. Sometimes caps are employed to cover the connector to keep it sterile. Frequently, these caps are lost, or
15 simply not used because they are not readily available when needed.

A closed, patient access system that is easy to use and employs only a valve device in communication with the patient that need not be capped or interconnected with the medical implement through a needle or adaptor, is swabbable, is sufficiently durable to maintain its function after several manipulations, and maintains a fluid-tight seal at high
20 pressures, would be of great benefit to the medical community.

Summary of the Invention

The valve of this invention has several features, no single one of which is solely responsible for its desirable attributes. Without limiting the scope of this invention as expressed by the claims which follow, its more prominent features will now be discussed
25 briefly. After considering this discussion, and particularly after reading the section entitled, "DETAILED DESCRIPTION OF THE PREFERRED EMBODIMENTS," one will understand how the features of this invention provide its advantages, which include safety, reliable and repeatable performance, elimination of dead space, simplicity of manufacture and use, and employment of a valve that is swabbable after use to provide
30 sterility and has a fluid-tight seal at high pressure.

This invention is a closed, patient access system which automatically reseals after administering medication using a medical implement that directly connects with the system without the need of any intermediate needles, caps or adaptors. A two-way valve is employed utilizing a reusable seal that may be repeatedly pierced by an enclosed,

-3-

protected, non-metallic spike rather than an exposed metal needle. The valve facilitates fluid, particularly liquid, transfer while maintaining sterility. The valve is easy to use and is capable of locking in place. After use, the valve is swabbed in the conventional manner with a suitable substance to maintain sterility. The design of the valve avoids
5 accidental needle sticks. As will be discussed in detail below, the valve is useful as a medical connector or adaptor to enable liquid flow from a sealed container.

The first feature of this invention is that the valve has a body including wall structure defining an internal cavity having a proximal end and a distal end. The cavity has an open space into which the seal is pushed, and preferably has a plurality of radial
10 indentations in the wall structure that are adjacent the seal to accommodate the expansion of the seal upon compression. The proximal end has an opening sufficiently large to receive a delivery end of a medical implement which transfers fluid through the delivery end. In most applications, the delivery end of the implement is tapered, and the wall structure adjacent the opening is tapered inward so that the wall structure and the
15 tapered delivery end fit snug against each other upon insertion of the delivery end into the opening. The proximal end of the cavity preferably is adapted to fit snug with an ANSI (American National Standards Institute, Washington, D. C.) standard end of the medical implement. Typically, the implement is a syringe, a connector or inlet/outlet of an IV set, or any one of a wide variety of conduits used in medical applications.

The second feature is that the spike has a tip with at least one hole located at or
20 near the tip, and a passageway in communication with the hole that allows fluid to flow through this hole. The spike is seated inside the cavity such that the tip is inward of the proximal end and is enclosed within the cavity. Preferably, the hole is in a side of the spike adjacent the tip and is elongated, having a size of 18 gauge or greater. The tip
25 may be sharp or slightly rounded. More than one hole is desirable for many applications, and three, symmetrically located holes inward of the proximal end are preferred. The spike may include at least one rib which allows air to enter a space between the seal and the spike, thereby facilitating the sealing of the opening when the implement is removed. The spike may have a substantially conical shape, and the seal has a complementarily,
30 substantially conical shaped cavity within it conforming to the shape of the spike. The spike is disposed within this conical cavity and the seal covers the tip. The tip may be imbedded in the proximal end of the seal or withdrawn into the conical cavity. Preferably, the tip of the spike has a plurality of facets which meet within a recess. The preferred spike should be able to penetrate the seal repeatedly without tearing the seal. Rough

-4-

edges at the tip may present a tear problem. During injection molding of the preferred plastic spike, facets of the tip will abut along a "parting line," and could form a rough edge which may tear the seal. This problem is avoided where the parting line is buried in a recess. Any rough edge at this parting line is disposed within a recess, so the seal material moves over the recess and does not contact the rough edge.

5 The third feature is that the resilient seal is adapted to be moved into a compressed state upon insertion of the tip of the medical implement into the opening and returns to a decompressed state upon removal of the tip. The seal in the decompressed state has a section which fills essentially completely a portion of the cavity adjacent the opening. The seal section bears against the wall structure near the opening to seal the opening. In the compressed state, the seal section is pushed by the delivery end of the medical implement away from the opening and into the cavity. A fluid tight seal is maintained between the seal section and the wall structure as the seal is moved into the compressed state. The seal section bears against the wall structure as the seal is moved inward into the cavity by the tip of the medical implement. And most importantly, the delivery end and the seal are adapted to engage so that when the tip of the spike pierces the seal there is essentially no dead space between said delivery end and the seal. Consequently, a predetermined dosage amount of medication is transferred in its entirety to the patient using this invention, with none to the prescribed amount being collected in dead space in the valve. The delivery of an exact amount of medication may be critical in some situations when chemotherapeutic agents are being administered or small children are being treated.

10 A fluid tight seal is maintained over repeated opening and closing of the valve, and the seal has on its external surface a recess which provides an air pocket to facilitate the movement of the seal. Preferably, the seal presents an essentially flush surface with the proximal end of the cavity. In one embodiment, the proximal end of the seal is substantially flat, the seal is made of a material having a hardness of from 30 to 70 Shore units such as, for example, a silicone polymer. The seal may include a cup-like flange adapted to engage the body near the proximal end of the cavity. A preferred embodiment of the seal comprises a series of O-ring elements stacked together and connected to form a unitary structure. The O-ring elements have increasing diameters, with the smallest diameter element being adjacent the proximal end of the cavity. The proximal end of the seal may be precut to form a tiny orifice therein that allows the tip of the spike to pass therethrough easily upon compression of the seal. Preferably, the

-5-

proximal end of the seal has a truncated conical shaped segment disposed within the cavity. The seal may also have a centrally located, anti-vacuum, saucer like depression therein, which does not interfere with the ability of the exposed, proximal end of the seal being swabbed when desired.

5 The fourth feature is that the body and spike are two separate components of the valve that are securely attached to each other by assembly of, and interlocking, of the body and spike. The body has a first locking element near the distal end of the cavity, and the spike has a second locking element adapted to interlock with said first locking element upon assembly. The seal has a lip extending beyond the distal end and
10 positioned between the first and second locking elements so that, upon assembly, the lip is compressed between the locking elements to provide an essentially fluid tight seal upon interlocking.

 The fifth feature is that the medical valve includes a support member connected to the spike which seals off the distal end of the cavity. The support member may have
15 a Luer-Lock type connector element that enables the valve to be removably attached to, for example, a fluid line connected to a patient. The support member may also be in the form of an adaptor that enables the valve to be removably attached to a fluid dispenser or container. When used to dispense fluids from a container, the spike has a pair of opposed tips, respectively at the distal and proximal ends of the spike. The tip at the
20 distal end of the spike pierces a cover member which seals the container. A radial slit on the adaptor enables it to deform reversibly sufficiently to fit snugly onto said container.

 The sixth feature is that the seal has a proximal end including a pressure responsive element disposed on an inner surface of the seal adjacent the opening. The pressure responsive element in the decompressed state closes any orifice in the seal at
25 the proximal end of the seal to provide an essentially fluid-tight seal while in the decompressed state. The pressure responsive element enables the valve to maintain a fluid-tight seal even at very high pressures sometimes experienced in medical applications, particularly when the valve is connected to a patient's artery. The valve of
30 this invention will remain closed even when the pressure inside the valve is above 6 pounds per square inch (psi), and it can withstand pressures above 30 psi. Typically, the pressure responsive element is a section of the seal having an entryway into a precut orifice. This section has a substantially cylindrical configuration and is surrounded by an annular space which is filled with pressurized fluid. The center of the member and the annular space are coaxial with the entryway to the orifice. The pressurized fluid fills

the annular space to apply pressure that compresses the cylindrical section to tightly close the entryway to the orifice. Preferably, the pressure responsive element has an anti-tear element.

In accordance with this invention, a known, prescribed, predetermined amount
5 or dosage of medication may be transferred from the remote source to the patient directly, so that essentially none of said predetermined amount is collected in dead space in the valve. In other words essentially all the prescribed dosage is receive by the patient and not lost in the valve. Thus, this invention also includes a method of transferring fluid from a remote source to a patient. This invention also includes transfer of fluid from the
10 patient to a remote source. This is possible because the valve of this invention provides two-way communication. The fluid is transferred to the patient by applying pressure the fluid as it passes through the implement so that the pressure applied to the fluid is greater than the pressure of fluid in the patient, enabling transfer from the remote source to the patient. To achieve transfer of fluid from the patient to the remote source, the
15 pressure of fluid in the patient is greater than the pressure at the remote source, causing fluid to flow from the patient to the remote source. This invention also includes a method of transferring fluid in a container having an open mouth covered by a cover member which seals the open mouth. The fluid is caused to flow from the container through the passageway by creating a differential in pressure. Preferably, the valve has an adaptor having a radial slit for allowing the adaptor to deform reversibly sufficiently to fit snugly
20 onto said container.

Brief Description of the Drawing

The preferred embodiments of this invention, illustrating all its features, will now be discussed in detail. These embodiments depict the novel and non-obvious method
25 and valve of this invention shown in the accompanying drawing, which is for illustrative purposes only. This drawing includes the following Figures, with like numerals indicating like parts:

Figure 1 is a perspective view of the first embodiment of the valve of this invention.

Figure 2 is an exploded perspective view of the valve shown in Figure 1 illustrating
30 the spike, seal, and the body or housing components of the invention.

Figure 3 is a longitudinal cross-sectional view of the assembled valve of Figure 1.

Figure 4 is a schematic, longitudinal, cross-sectional view of the assembled valve of Figure 1 before compressing the seal.

Figure 5 is a schematic, longitudinal, cross-sectional view similar to Figure 4

-7-

showing the valve during compression of the seal.

Figure 6 is a perspective view of a second embodiment of the invention.

Figure 7 is a longitudinal cross-sectional view of the valve of Figure 6.

5 Figure 8 is a schematic illustration of an ANSI delivery end of a medical implement compressing the seal of the valve of this invention.

Figure 9 is a side elevation view, partially in cross-section, of a third embodiment of the seal.

Figure 10 is a longitudinal cross-sectional view of the assembled valve of Figure 1 using the seal of Figure 9.

10 Figure 11 is a longitudinal cross-sectional view of the assembled valve of Figure 1 using a fourth embodiment of the seal.

Figure 12 is a longitudinal cross-sectional view of the assembled valve of Figure 1 using a fifth embodiment of the seal.

Figure 13 is a longitudinal cross-sectional view of a sixth embodiment of the seal.

15 Figure 14 is a longitudinal section of the seal shown in Figure 13 used in connection with the spike device shown in Figure 2.

Figure 15 is a longitudinal partial cross-sectional view of a seventh embodiment of the seal of this invention.

20 Figure 16 is a longitudinal cross-sectional view, after assembly, of the embodiment of the valve shown utilizing the seal of Figure 15.

Figure 17 is a longitudinal cross-sectional view, after assembly, of the eighth embodiment of the valve of this invention.

Figure 18 is a longitudinal cross-sectional view, after assembly, of the ninth embodiment of the valve of this invention.

25 Figure 19 is a side elevation view, after assembly, of the seal and spike shown in Figure 14 connected to the body or housing shown in Figures 20 and 21.

Figure 20 is a cross-sectional view taken along line 20-20 of Figure 19.

Figure 21 is a perspective view, with sections broken away to show the wall structure of the cavity containing the seal shown in Figures 13 and 14.

30 Figure 22 is a greatly enlarged, cross-sectional view taken along line 22-22 of Figure 14.

Detailed Description of the Preferred Embodiments

The term "proximal" is used to denote the end of the valve and other components at or near the spike tip 32 in Figures 2 through 5, 10 through 12, 14, and 16, and at or

near the spike tip 60 in Figure 6, and at or near the seal cap 92 in Figures 8, 9, 13 through 19. The term "distal" is used to denote the opposite end of the valve, or spike tip, or seal. The term "medical implement" is used to denote any medical tool known to those of skill in the art that can connect to the present invention and facilitate the passage of fluids, particularly liquids, through the instant invention. Examples of medical implements that are contemplated include, but are not limited to, tubing, conduit, syringes, IV sets (both peripheral and central lines), piggyback lines, and other components which can be used in connection with a medical valve. Medical implements are commercially available in standard sizes. Thus, either or both ends of the valve of this invention can be provided with fittings to accommodate such standard size medical implements.

As best shown in Figures 1 and 2, the first embodiment of the invention, valve 10, includes a valve body or housing 12, a spike element 24, and a seal 36. The seal 36 is prepared from a resilient material that is flexible, inert, impermeable to fluid, and readily pierceable by the spike 26. In the embodiment shown in Figure 13 depicting an alternate shaped seal 36d, this seal 36d has a precut slit 11 in its proximal end. This provides a tiny orifice through which the tip 32 of the spike element 24 may easily pass, yet still provides a fluid tight seal upon withdrawal of the spike element. These three components are assembled, as depicted in Figure 3, with the spike element 24 enclosed to prevent accidental sticks. Figure 2 illustrates how the housing 12, seal 36, and spike element 24 are attached without the need to use any adhesive or other bonding agent or process. Mechanical connection which provides a fluid tight closure is attained as is discussed subsequently. As shown in Figures 4 and 5, the seal 36 moves within the housing 12, being pierced by the spike element 24 to expose the tip 32 of the spike element 24 to allow fluid to flow through the valve 10.

Referring to Figure 1, one preferred embodiment of housing 12 has a bell-shaped skirt 16 and an upper, preferably cylindrical, conduit 20. The skirt 16 is integral with, and connected by an annular ring 14, to the upper conduit 20. The skirt 16 creates a shield for an inner conduit 18 of the spike element 24. This inner conduit 18 is preferably cylindrical in shape, and slightly tapered. Inner conduit 18 and upper conduit 20 comprise aligned hollow tubes so that inner conduit 18 and upper conduit 20 are in fluid communication with one another when the spike element 24 pierces the seal 36. There is an annular lip 25 surrounding a circular opening 25a in the top of the conduit 20 (see Figure 2).

In the first embodiment, the upper conduit 20 is adapted to receive the tip or nose 48 of an ANSI standard syringe 46 (see Figures 4 and 5). It is, however, contemplated that the outer diameter of the upper conduit 20 can be of any size to accommodate the attachment of other connector devices thereto. Advantageously, the proximal end of the upper conduit 20 can be equipped with a locking mechanism to facilitate locking of the valve 10 to a variety of connector devices. For example, referring to Figure 1, locking ears 22 near the proximal lip 25 of housing 12 are preferably provided such that the housing 12 can be locked into any compatible Luer-Lock device known to those with skill in the art. For example, referring to Figure 19, conventional Luer-Lock threads 180 can be provided on the outer diameter of upper conduit 20.

Referring to Figure 2, the spike element 24 has at its distal end the inner conduit 18 and at its proximal end a hollow spike 26 which is integral with the inner conduit. The inner conduit 18 and spike 26 present a continuous passageway for fluid during use. An annular cuff 28 on an intermediate portion of the spike element 24 is integral with, and interconnects, the inner conduit 18 and the spike 26. As illustrated in Figure 3, the rim 28a of the cuff 28 abuts the underside of the inner ring 14, and has an annular detent 28b that snaps into an annular groove 14b in the underside of the ring. The cuff 28 serves two functions. First, it serves as an attachment device to the underside of the annular ring 14. Second, it serves as a support and attachment device for the seal 36.

The hollow spike 26 has a tapered conical shape, ending in a sharp, pointed tip 32. Preferably, along the length of the spike are raised, protruding ridges 30. These raised ridges 30 extend from the surface of the spike preferably between 0.2-2.0 mm. The ridges 30 are preferably aligned along the length of the spike as illustrated in Figure 2. These ridges 30 serve to break any vacuum created when the spike 26 is sealed as described hereinbelow. Modifications to the alignment and orientation of the ridges are discussed hereinbelow in association with their function. Just distal the spike tip 32, there is situated at least one longitudinal through-hole 34 to permit fluid communication between the inner conduit 18 and the upper conduit 20. Preferably, there are three through-holes 34 within about 0.200 inch from the spike tip 32. These through-holes 34 may be of any size, however, the larger the size of the through-holes the greater the fluid flow rate through the valve 10. In a preferred embodiment, the size of the through-holes 34 are 18-gauge to provide a flow rate three times that of a standard 18 gauge needle.

The seal 36 has a seal cap 40 with a generally flat top surface 40b, an outwardly tapered sidewall 38, and a lower lip 42. Its interior is hollow to provide the conically

-10-

shaped cavity 37 (Figure 3). Thus, the seal 36 slips easily over the spike element 24 to fit snugly within the cavity 37. The seal lip 42 is seated within the annular cuff 28 and wedged between the cuff and the underside of the ring 14. There are longitudinal grooves 43 (Figure 2) along the length of the seal 36 which provide air pockets that facilitate compression of the seal 36 during use. The grooves 43 may be of variable shape or size to facilitate seal compression. In the first embodiment, there is a single groove 43 which completely surrounds the seal 36 between the seal cap 40 and the lip 42.

The base of the seal 36 has a width such that the seal lip 42 fits snugly into the annular cuff 28. The hollow interior or cavity 37 (Figure 3) of the seal 36 is preferably tapered to conform internally to the shape of the spike 24, having a wall portion 44 which contacts the spike 24 distal seal cap 40. The exterior of the seal 36 is sized and shaped to fit inside the upper conduit 20 of the housing 12. The cap 40 reseals the valve 10 when the top surface 40b is above the through-holes 34. Preferably, the cap 40 substantially fills the opening 25a in the top of the conduit 20. Thus, after assembly, the top surface 40b of the seal cap 40 is essentially flush with the lip 25, so that the lip 25 and seal cap 40 can be swabbed with alcohol or other disinfectant without leakage of disinfectant into the valve 10. It is important that the surface 40b be exposed so that it may be swabbed with a disinfectant.

As best shown in Figure 3, the spike 24, with contiguous inner conduit 18, is affixed to the housing 12 through the association of the external portion of annular cuff 28 and the internal portion of annular ring 14. Although not necessarily required, these two pieces may be affixed by any one of a variety of methods known to those of skill in the art including, but not limited to, heat sealing, glue, pressure lock, bonding or the like. The seal 36 fits into the annular cuff 28 and is held in place by an internal lip 27 along the internal portion of the annular ring 14 of the housing 12. The length of the spike 24 is such that, after assembly, the tip of the spike rests below the plane defined by the lip 25 of the housing 12. Preferably, the spike tip 32 is approximately from .525" to .1" below the lip 25 of the housing 12. The seal 36 fits snugly against the spike 24 and is essentially flush with the lip 25 of the housing 12. The spike tip 32 is thus embedded within the seal cap 40 prior to use or may be approximately .025" distal the seal cap 40 when the valve 10 is in the closed position. The inner conduit 18 is partially shielded by the bell shaped skirt 16 of the housing 12 (see Figures 1-3). The inner surface of the bell shaped skirt 16 preferably has protruding threads 44 as an optional locking mechanism

-11-

for attaching a medical implement thereto. Further, other medical devices can be pressure fit over the outer portion of inner conduit 18 without direct association with the protruding threads 44.

During use, the invention is designed to be adapted as a two-way valve. The orientation of the valve is independent to fluid flow and dependent on the preferred orientation of the preexisting connections. Thus, the invention can be used as a valve connector for an intravenous central or peripheral piggyback connector in either orientation. Parenteral fluid is delivered to patients through tubing such that the liquid flows from a container through a needle into the patient. The containers are frequently changed or additional fluid bottles are added. The invention disclosed herein is designed to interconnect medical implements along the route of fluid delivery to the patient. However, the invention is also useful in any environment in which a resealable fluid valve is desired. During use, a connector of the appropriate size is fitted over the inner conduit 18. Locking can be achieved by a Luer-Lock mechanism, a pressure fit or any other locking mechanisms known to those with skill in the art, as described above. Thus, in one example, fluid passes from the inner conduit 18 into the spike 26. However, fluid flow is locked in place by the seal 36.

Figures 4 and 5 illustrate valve activation. In Figure 4, the medical implement connecting to the proximal end of the valve 10 is a syringe 46. However, this connecting implement could be any number of medical implements known to those of skill in the art. The nose 48 of the syringe 46 is placed on the seal cap 40 inside the lip 25 of the housing 12. The application of pressure on the syringe 46 in the direction of the arrows, as illustrated in Figure 4 creates pressure on seal cap 40. The resulting downward pressure compresses the seal 36. This pushes the tip 32 of the spike 26 through the seal cap 40 to expose the through-holes 34. Compression is facilitated by the grooves 38. Fluid is now able to flow into the syringe 46, or vice versa, depending on whether fluid is to be withdrawn from the patient or medication injected into the patient. Figure 5 shows valve 10 opened by insertion of the nose 48 of the syringe 46 into the opening 25a. A syringe plunger 49 in the syringe 46 is retracted thereby creating a vacuum to draw fluid through the valve 10 into the syringe. For intravenous applications, the valve 10 can be orientated in the position diagramed in Figures 4 and 5, or it can be rotated 180° such that fluid flows in the opposite direction.

Upon removal of the syringe from spike 26, as shown in Figure 4, the seal 36 is free to return to its original shape and cover through-holes 34. The ability of the seal 36

-12-

to return to its original shape is determined by the resiliency of the material used to prepare the seal 36. In addition, the ability of the seal 36 to return to its original shape is facilitated by the protruding ridges 30 formed on the external surface of the spike. During compression, a vacuum may form in the area between the spike 26 and the seal 36, thereby preventing the seal 36 from returning to its original position. The protruding ridges permit air to pass along the spike/seal interface to prevent vacuum formation and allow free return of the seal. The ability of the seal 36 to deform reversibly and return to its original position is particularly useful because (1) it immediately stops fluid flow through the valve 10, (2) it covers the recessed spike 26 to maintain its sterility, and (3) it reduces the risk that the spike could inadvertently pierce another object or person. In addition, since the valve 10 lacks movable parts, except for the seal, it is unlikely that when the seal 36 is pushed down, the valve 10 would fail to function.

Advantageously, the through-holes 34 are located relatively low on the spike 26. Thus, the through-holes 34 are sealed relatively early in the process as the seal 36 returns to its original configuration with the valve 10 is closed. In one preferred embodiment the through-holes 34 are located .075" below the spike tip 32 (see Figure 2). Additionally, the through-holes 34 are sealed even if the seal 36 does not fully return to its original configuration depicted in Figure 4. Further, the ability of the seal 36 to return reversibly to its original position permits the reuse of the connector valve 10. Following disconnection, and before reuse, the surface of pierced seal cap 40 is essentially flush with the housing 12. Thus, this flush surface can, advantageously be sterilized with alcohol or other surface decontaminating substances. The skirt 16 and upper conduit 20 advantageously shield both connections from the surrounding environment to protect the sterility of the connection. Further, both the skirt 16 and upper conduit 20 function as collection reservoirs to prevent fluid from dripping from the valve 10 during manipulation.

A cover cap (not shown) can be supplied to fit over the upper conduit 20 as further protection for the seal surface between use. Such a cover cap, however, is not needed to maintain sterility since the seal 36 may be swabbed with a disinfectant after each use. The reversibility of the seal 36 makes the valve 10 particularly attractive as a connector valve to provide fluid communication between two fluid lines. Therefore, the present invention provides for placing a first fluid line in communication with a second fluid line using the valve disclosed herein. The reversibility of the valve 10 permits multiple fluid lines to be successively added, for example, to a fluid line in direct

-13-

communication with a patient's vein. Since the valve is easily sterilizable and sealable, fluid lines can be added and removed without disconnecting venous contact.

5 The valve 10 is preferably prepared from a hard plastic, but it is additionally contemplated that the valve could be prepared from other medically inert materials known to those in the art. The spike element 24 is preferably prepared from the same material as the housing 12. One particular advantage of this invention is that it does not rely on the use of metal needles. This dramatically reduces the risk of skin puncture during use and manufacture. Further, the upper conduit 20 serves as a shield to the spike 26 such that skin puncture is further reduced. The spike 26 need only be strong enough to
10 penetrate the seal cap 40, or if necessary, to pierce a connecting septum.

In the embodiment of the invention illustrated in Figures 2-4, the through-holes 34 are placed distal spike tip 32. This placement provides two important advantages. First, the placement of the through-holes 34 facilitates resealing of the valve 10 after use. Second, if the through-holes were placed at the spike tip 32, the holes 34 may core the seal cap 40 thereby introducing seal particulate into the fluid flow and possibly plugging the holes 34. Thus, the longitudinal placement of the through-holes distal spike tip 32 prevents the introduction of particulates into the fluid path and/or plugging of the through-holes 34. It is additionally contemplated that the number and diameter of the through-holes 34 can be adjusted to accommodate different fluid velocities. In a preferred embodiment, the preferred velocity of fluid passing through the through-holes
15 34 is equal to or greater than the flow rate through an 18 gauge needle. Through-holes larger than 18 gauge will, of course, facilitate greater fluid velocities.

An important advantage of the invention is that the valve 10 has very little dead space, thus the volume of liquid entering into the valve is substantially equivalent to the volume of fluid leaving the valve. Further, the total equivalent fluid volume of the valve is very small such that the volume of fluid flowing through the system in order to place
25 the valve in fluid communication with a medical implement such as a syringe 46 is substantially zero.

Alternate Embodiments

30 In another preferred embodiment of the invention, illustrated by Figures 6 and 7, a disposable sterile adaptor valve 50 is provided to function as a resealable lid for a container (not shown) of fluid. The fluid can thus be removed from the fluid container or permitted to flow from the container into a medical implement adapted to house fluid in a sterile manner. As is the conventional practice, an open mouth of the container will

-14-

ordinarily be sealed with a cover member (not shown).

Figure 6 shows an adaptor valve 50 having a body including an adaptor skirt 52. The adaptor skirt 52 will preferably fit snugly over the open mouth of the container. The skirt 52 may be of any size to accommodate a range of container sizes. A lengthwise slit 54 is preferably provided in at least one location along the length of the skirt to ensure a snug fit between the skirt 52 and the container. A chamber 56, preferably tubular in configuration, extends upward from the skirt 52 and is similar in construction and design to the upper chamber 20 of the first preferred embodiment. Similar to the first embodiment, the proximal portion of the valve contains a locking mechanism 59 that preferably comprises a Luer-Lock device or other locking device known to those of skill in the art.

As depicted in Figure 7 a spike 58 extends upward through a tubular chamber 56. A spike tip 60 is preferably recessed from a proximal lip 62 of the tubular chamber 56. In a closed position, this tip 60 is covered by a seal 64, which is essentially the same as seal 36. Protruding ridges 66 and seal grooves 68 facilitate seal compression in the open position and promote closure following use. Thus, in the closed position as illustrated in Figure 7, the seal 64 covers the through-holes 70 to prevent fluid out-flow from the container. The adaptor valve 50 contains a second spike 72 which points in the opposite direction as spike 58. These spikes 52 and 72 are in fluid communication with each other. The spike 72 extends downward inside the adapter skirt 52. The two spikes preferably form one component of the valve 50 while the skirt 52 and upper chamber form a second component. These two components can be assembled in a manner like that of the valve 10. The spike 72, like the spike 58, has longitudinal through-holes 74 and a tip 76. The through-holes 74 are located inward of the tip 76. The adaptor valve 50 is thus useable with containers holding sterile medicament having a cover or septum seal at the open mouth of the container. Examples of containers with such seals contemplated for use with this invention include dosage bottles for intramuscular injector antibiotic containers or the like. However, it is also contemplated that the valve 50 can be adapted with its own seal and locking mechanism to permit the valve to be employed on a variety of containers for medicaments or other fluids. Medicaments in these types of containers are preferably maintained under sterile conditions and the volume and nature of the medicament is such that multiple aliquots are intermittently removed over time. If the medicament is reconstituted, then, during use, any covering over the opening on the container is removed to reveal the rubber septum. The adaptor valve 50 is placed

-15-

over the septum and direct pressure is applied to pierce distal spike 72 through the septum and into the container. A syringe or the like can then be applied, as depicted in Figure 4, in association with the first preferred embodiment, to withdraw fluid from the container. The pressure of the nose 48 over the spike 58 pushes spike tip 60 through seal 64. At the same time, seal 64 is pushed back and compresses. Compression is accommodated by seal grooves 68. Fluid is withdrawn from the container and the syringe is removed from the spike 58. Release of the pressure applied to seal 64 permits the seal to return to its original configuration. The spike ridges 66 facilitate seal reversibility.

Often the ingredients housed in containers are those that can be lyophilized at purchase. Lyophilized ingredients require reconstitution before use. If the medicament requires reconstitution before use, then sterile water, saline, or other fluid can be introduced into the container before fluid is extracted. The two-way nature of the valve permits this without any special adaptation. After the syringe is removed, the adaptor valve 50 automatically seals. Subsequently, aliquots can be removed from the container by syringe or the like. Alcohol or other compatible surface sterilizing agent can be used to wipe the lip 62 and seal 64 before each use. Similar to the first embodiment, it is additionally contemplated that a cap can be provided to fit over upper chamber lip 62 between use.

The adaptor valve 50 can be adapted to function as a medicament adaptor for an intravenous container. In this case, the adaptor valve 50 is placed on a medicament container for intravenous delivery and attached via tubing to an intravenous feed. Thus, the adaptor valve 50 can be placed in fluid communication with a connector valve of Figure 1 to facilitate the flow of medicament from intravenous drip bottles.

An alternative embodiment of the seal, a seal 36a, is shown in Figure 9. Seal 36a comprises a seal cap 92 at the proximal end thereof and a seal lip 96 at the distal end thereof. A cup-like annular flange 95 is provided proximal seal cap 92. The seal cap 92 and seal lip 96 are connected by a seal wall consisting of a plurality of ringed wall portions 94 that expand and collapse in an accordion like fashion. During compression of the seal 36a, the diameter of the ringed wall portions 94 expand outward in the radial direction. There are air pockets 13a (Figure 10) between ring portions 94 and the housing and air pockets 13b between spike 24 and seal 36a. The seal 36a contains a cavity 98 distal seal cap 92 and adjacent the ringed wall portions 94. The seal 36a interacts with spike 26 (Figure 2) and other components of the present invention in a

-16-

similar fashion to seal 36 of Figure 2.

Referring to Figure 10, the cup-like annular flange 95 may be stretched around the upper conduit 20 and held in place by an annular ring 97. This creates a trampoline like effect that assists returning the seal 36a to a decompressed state after withdrawal of a syringe (not shown). This embodiment has two advantages. First, the proximal end of the valve 10 can be swabbed with alcohol or other disinfectant without leakage of disinfectant into the valve 10. Second, by affixing cup-like annular flange 95 to upper conduit 20 at the proximal end thereof with annular ring 97, the repeated deformation and reformation of the seal 36a is assisted.

An alternative embodiment of the seal, a seal 36b is shown in connection with the valve 10 in Figure 11. The seal 36b is similar to the seal 36a and is comprised of seal cap 92, a side wall consisting of ringed wall portions 94 and a seal lip 96. It also has an outwardly extending ring 99 which is at a right angle with respect to the longitudinal axis of the valve 10. This ring 99 is used to attach the seal 36b to upper conduit 20. Preferably, an upper conduit annular plug 20' is inserted within upper conduit 20 to create a tight fit between perpendicular ring 99, a ledge 101 in the upper conduit 20, and the plug 20'. The ring 99 assists in the reformation of seal 36b to enclose spike 26 upon withdrawal of a syringe (not shown).

As shown in Figure 12, the cup-like annular flange 95 and ring 99 may both be used in connection with the valve 10, to provide the seal 36c. This seal 36c, provides rapid reformation upon withdrawal of a syringe (not shown) and realizes the advantages of both the seals 36a and 36b.

Another alternative embodiment of the seal, a seal 36d, is shown in Figure 13. In this embodiment, the seal 36d is comprised of seal cap 92, seal lip 96, and a side wall 150 comprised of circular tires 100 stacked in series one on top of an adjacent larger diameter lower tire. The circular tires 100 are preferably solid throughout the diameter of the cross-section thereof. These circular tires 100 will deform and reform upon, respectively, compression and decompression of the seal 36d, thereby exposing or covering a spike (not shown) as the case may be.

As mentioned above, preferably seal 36d has a precut slit 11 in the cap 92 lying along the longitudinal axis of the valve 10. The seal cap 92 has a unique configuration that insures that the slit 11 closes and is sealed upon withdrawal of a syringe (not shown) and reformation of the seal 36d. It includes an enlarged, internal, pressure responsive member 200 which is integral with the cap 92. Between the proximal end of the side wall

-17-

150 and the member 200 is an annular space 102 which is filled with the fluid in the cavity 98. This fluid is under pressure, for example at the blood pressure of the patient to which the valve 10 is attached. Referring to Figure 14, fluid, for example the patient's blood, flows through the holes 34 in the spike 26, filling the cavity 102. This fluid presses against the exterior of the member 200, closing the slit 11 when the seal is decompressed as shown in Figures 14 and 19. The pressure from this fluid creates a high pressure seal which prevents fluid from escaping valve 10 through the slit 11. There is a semi-cylindrical annular flange tear ring 104 on the end of the member 200 which advantageously extends the useful life of seal 36d.

10 Preferably, there is a tear ring 104 integral with the member 200 along the perimeter of the internal surface the member 200, and a slight saucer-like depression 204 in the external surface of the seal. The pressure responsive element in the decompressed state closes any orifice in the seal 36d to provide an essentially fluid-tight seal while in the decompressed state. The pressure responsive member 200 enables the valve to maintain a fluid-tight seal even at very high pressures sometimes experienced in medical applications, particularly when the valve 10 is connected to a patient's artery. The center of the member 200 and the annular space 102 are coaxial with the entryway 11a to the orifice 11. The pressurized fluid fills the annular space 102 to apply pressure that compresses the member 200 to tightly close the entryway to the orifice. In a preferred embodiment the distance from the entryway 11a to the proximal end of seal cap 92 is from .500 to .075 inches and more preferably approximately .100 inch.

25 As best illustrated in Figure 22, the tip 32 is designed to avoid tearing the seal. Tip 32 has three facets 210, 212, and 214 which are joined with each other along parting lines a, b, and c. This junction of the facets 210, 212, and 214 frequently is ragged and will tear the seal 36d. This is prevented by the parting lines a, b, and c, or junctions, being disposed within recesses 220, 222, and 224, respectively, to provide "buried parting lines."

30 Another alternative embodiment of the present invention using the seal 36d is shown in Figure 8 and Figures 19 through 21. In this embodiment, the inner wall 160 of the upper end of the conduit 20 is provided with at least one, and preferably, a plurality of radial indentations 107. The indentations 107 are elongated disposed generally parallel to the longitudinal axis if the valve 10 in a symmetrical, star-like configuration. Each indentation has opposed lateral edges 162 which engage the seal 36d upon compression of the seal 36d. The indentations provide space into which the seal 36d expands upon

-18-

compression.

As best shown in Figure 8, the wall 181 of the proximal end of the conduit 20 is tapered inward at the same angle as the nose 48 of the syringe 46. In accordance with ANSI standards, the taper is 0.006 inch per linear inch. The wall 182 of the syringe nose 48 bears against the wall 181 as the nose slides into the opening 25a to push the seal 36d inward compressing it and forcing the tip 32 of the spike 36 to enter the slit 11. The seal 36d expands upon compression to fill essentially completely the upper portions of the indentations 107. Some sections of the seal 36d are wedged between the edges 162 and other sections fill the indentations 107. As the liquid flows through the nose 48 through holes 34, air in the nose 48 is forced out of the nose 48 and expelled from valve 10 between walls 181 and 182. Thus, essentially the entire prescribed dosage is delivered through valve 10 to the patient. Fluid flows through the through-holes 34, but does not leak between either the seal 36d and the wall 181 or between the abutting walls 181 and 182.

Figures 15, 16, 17, and 18 depict embodiments of seals, namely, seal 36e, seal 36f, and seal 36g, which are substantially the same as the seals 36a (Figure 10), seal 36b (Figure 11), and seal 36c (Figure 12), except the side wall 150 employing the circular tires 100 is used in place of the accordion wall portion 94.

Other components of the present invention interact with the various embodiments of the seal in a similar fashion to their interaction with seal 36 of Figure 2. Prior to use of valve 10, it is preferable that the seal caps 40 or 92 be pierced centrally by a steel needle in the axial direction, precutting the seal to provide the slit 11 in order to allow for more rapid decompression and reformation of the seal upon piercing by the spike 26. The seals are advantageously formed from a material which can repeatedly reseal and prevent fluid from flowing around the seal material. The seal 36 should also be capable of being forced down and then spring back into position to reseal the valve. Material that is too soft will reseal effectively; however, will not be capable of springing back after opening of the valve. Material that is too hard will provide sufficient spring force; however, will not effectively seal. Thus, in a preferred embodiment, the seal is formed from a silicone having a hardness in the range from 30-70 Shore durometer units, and more preferably in the range 40-50 Shore durometer units. A cure silicone polymer in the preferred hardness range is available from Wacker Silicone Corp. of Adrian, Michigan. In some embodiments of the invention, it is desirable to provide additional lubricity to the seal 36 to allow it to spring back and reseal more effectively. Dow Chemical Co.

-19-

produces a silicone formulation with silicone oil built in to provide this additional lubricity.

In general, the closing of the valve 10 is provided not by the side wall of the seal 36 which immediately covers the through-holes 34, but by the seal cap 40, or seal cap 92 filling the proximal end of the cavity 98 and the opening 25a. Thus, the seal caps 40 and 92 are sufficiently thick to reseal the opening 25a effectively after valve closure. However, the seal caps 40 and 92 should also be sufficiently thin to allow them to readily return to the closed position. Preferably the thickness of the caps 40 and 92 ranges between 0.075 and 0.500 inch and more preferably may be approximately .100 inch.

The valve disclosed in this invention can be provided in a sterile and disposable form such that after its use in a given installation is exhausted, the device is discarded. However, as described above, in any given installation, the device can be reused multiple times. Since the device does not employ needles, there is little chance that the device will inadvertently cause skin puncture. Therefore, the extra precautions required for handling and disposing of needles is obviated. It will be apparent from the detailed description provided herein that the present invention can provide for the elimination of nearly all needles used in the medical environment. With the use of the valve of the present invention, the need for all needles except those that are directly input into a patient is, advantageously, eliminated.

Operation

The valve 10 is used to provide a closed, patient access system for transferring a predetermined amount of medication from a remote source to the patient. The valve 10 is connected by the distal end to the patient, for example, a vein or artery in fluid communication with the valve. Blood fills the valve, but the seal 36d, for example, prevents any blood from leaking from the valve. The delivery end or nose 48 of the medical implement is inserted into the valve as depicted in Figure 8, pushing the nose 48 against the seal to compress the seal sufficiently to allow the tip 32 of the spike 24 to pierce the seal and enter said delivery end. The predetermined amount of medication in its entirety may now be transferred through the nose 48 into the valve 10 and into the patient. Since the nose 48 and seal 36d engage in a manner so that the tip 32 of the spike element 24, upon piercing the seal, meets the seal to avoid formation of any dead space at the interface between nose 48 and the seal surface 40b. Transfer directly through the valve 10 of essentially the entire predetermined amount of medication from the syringe 46 to the patient, so that essentially none of said predetermined amount is collected in any dead space in the valve, is accomplished with this invention. Upon

-20-

withdrawing the nose 48 from the valve 10 the seal 36d returns to the decompressed state to close the valve and maintain while in said decompressed state a fluid tight seal even at high pressures and after repeated uses.

Scope of the Invention

5 The above presents a description of the best mode contemplated of carrying out the present invention, and of the manner and process of making and using it, in such full, clear, concise, and exact terms as to enable any person skilled in the art to which it pertains to make and use this invention. This invention is, however, susceptible to modifications and alternate constructions from that discussed above which are fully
10 equivalent. Consequently, it is not the intention to limit this invention to the particular embodiments disclosed. On the contrary, the intention is to cover all modifications and alternate constructions coming within the spirit and scope of the invention as generally expressed by the following claims, which particularly point out and distinctly claim the subject matter of the invention.

15

-21-

1. A medical valve comprising:
a body including wall structure defining an internal cavity having a proximal end and a distal end,

said proximal end having an opening sufficiently large to receive a delivery end of a medical implement which transfers fluid through said delivery end,

a spike having a tip, at least one hole located at or near said tip, and a passageway in communication with the hole that allows fluid to flow through said hole,

said spike being seated inside the cavity such that said tip is enclosed within the cavity, and

a resilient seal which is adapted to be moved into a compressed state upon insertion of the tip of the medical implement into said opening and an returns to an decompressed state upon removal of said tip, said seal in the decompressed state having a section which fills essentially completely a portion of the cavity adjacent said opening, with said seal section bearing against said wall structure near said opening to seal said opening, and in the compressed state said seal section being pushed by the delivery end of the medical implement away from the opening and into the cavity.

2. The medical valve of Claim 1 where a fluid tight seal is maintained between said seal section and the wall structure as said seal is moved into the compressed state, said seal section bearing against the wall structure as the seal is moved inward into the cavity by said tip of the medical implement.

3. The medical valve of Claim 1 where the seal presents an essentially flush surface with said proximal end.

4. The medical valve of Claim 3 where the seal has a proximal end which is substantially flat.

5. The medical valve of Claim 1 including a support member connected to the spike which seals off the distal end of said internal cavity, said support member having a Luer-Lock type connector element that enables said valve to be removably attached to a fluid line connected to a patient.

6. The medical valve of Claim 1 including a support member connected to the spike which seals off the distal end of said internal cavity, said support member having a connector element that enables said valve to be removably attached to a fluid dispenser.

-22-

7. The medical valve of Claim 1 where the hole is in a side of the spike adjacent the tip.

8. The medical valve of Claim 1 where the seal comprises a material having a hardness of from 30 to 70 Shore units.

5 9. The medical valve of Claim 8 where the seal material is a silicone polymer.

10. The medical valve of Claim 1 where the seal comprises a series of O-ring elements stacked together and connected to form a unitary structure.

10 11. The medical valve of Claim 10 where the O-ring elements have increasing diameters, with the smallest diameter element being adjacent the proximal end of the cavity.

12. The medical valve of Claim 1 where the cavity has a plurality of radial indentations in an interior wall that is adjacent the seal to accommodate the expansion of the seal upon compression of said seal.

15 13. The medical valve of Claim 1 where the seal is precut to form a tiny orifice therein that allows the tip of the spike to pass therethrough easily upon compression of the seal.

14. A medical valve for use with a medical implement which transfers fluid through a tapered delivery end, including

20 a body including wall structure defining an internal cavity having a proximal end and a distal end, said wall structure tapering inward so that said wall structure and said tapered delivery end fit snug against each other upon insertion of the delivery end into the opening,

said proximal end having an opening sufficiently large to receive said delivery end,

25 a hollow spike having a tip and at least one hole located at or near said tip,

said spike being seated inside the internal cavity such that said tip is enclosed within the internal cavity,

30 a support member connected to the spike which seals off the distal end of said internal cavity, and

a resilient seal which is adapted to be moved into a compressed state upon insertion of the tip of the medical implement into said opening and an returns to an decompressed state upon removal of said tip, said resilient seal in the decompressed state having a section which fills essentially completely a

portion of the cavity adjacent said opening and covers said tip, with said seal section bearing against said wall near said opening to seal said opening, and in the compressed state said section being pushed by the delivery end of the medical implement away from the opening and into the cavity.

5 15. The medical valve of Claim 14 where a fluid tight seal is maintained between said seal section and the wall structure as said seal is moved into the compressed state, said seal section bearing against the wall structure as the seal is moved inward into the cavity by said tip of the medical implement.

10 16. The medical valve of Claim 14 where the seal presents an essentially flush surface with said proximal end.

 17. The medical of Claim 16 where the proximal end of the seal is substantially flat.

15 18. The medical valve of Claim 14 where the support member has a Luer-Lock type connector element that enables said valve to be removably attached to a fluid line connected to a patient.

 19. The medical valve of Claim 14 where the support member has a connector element that enables said valve to be removably attached to a fluid dispenser.

 20. The medical valve of Claim 14 where the hole is in a side of the spike element adjacent the tip.

20 21. The medical valve of Claim 14 where the seal comprises a material having a hardness of from 30 to 70 Shore units.

 22. The medical valve of Claim 21 where the seal material is a silicone polymer.

25 23. The medical valve of Claim 14 where the seal comprises a series of O-ring elements stacked together and connected to form a unitary structure.

 24. The medical valve of Claim 23 where the O-ring elements have increasing diameters, with the smallest diameter element being adjacent a proximal end of the seal.

30 25. The medical valve of Claim 14 where the cavity has a plurality of radial indentations in an interior wall that is adjacent the seal to accommodate the expansion of the seal upon compression of said seal.

 26. The medical valve of Claim 14 where the seal is precut to form a tiny orifice therein that allows the tip of the spike element to pass therethrough easily upon compression of the seal member.

 27. The medical valve of Claim 14 where the body has a first locking element

near the distal end of the cavity, the spike has a second locking element adapted to interlock with said first locking element, and the seal has a lip extending beyond said distal end and positioned between the first and second locking elements so that said lip provides an essentially fluid tight seal upon said locking elements interlocking and
5 compressing the lip therebetween.

28. The medical valve of Claim 27 where the seal has a truncated conical segment disposed within the cavity.

29. The medical device of Claim 14 where said seal includes a cup-like flange adapted to engage said body near the proximal end of the cavity

10 30. The valve of Claim 14 where said seal has an air pocket to facilitate the movement of the seal.

31. The valve of Claim 14 where said spike includes at least one rib which allows air to enter a space between said seal and said spike, thereby facilitating the sealing of said opening when said implement is removed.

15 32. The valve of Claim 14 where said valve is adapted to engage an implement selected from the group consisting of syringes, IV sets and conduits.

33. The valve of Claim 14 where said proximal end of said cavity is adapted to fit snug with an ANSI standard end of said medical implement.

34. The valve of Claim 14 wherein said spike has at least 3 holes.

20 35. The valve of Claim 34 where said holes are 18 gauge or larger.

36. The valve of Claim 14 where the valve includes an adaptor for connecting the valve to a container.

37. The valve of Claim 36 where the adaptor has a spike which is adapted to pierce a seal on the container upon connecting the valve to the container.

25 38. The valve of Claim 36 having a radial slit on said adaptor for allowing said adaptor to deform reversibly sufficiently to fit snugly onto said container.

39. A medical valve, including

a housing having wall structure defining an internal cavity having a proximal end and a distal end, with an opening at the proximal end and a first locking element at the distal end,

30 a spike with a fluid passageway therein that allows fluid to flow through said passageway, said spike having a second locking element adapted to interlock with said first locking element,

said spike including a tip and being mounted in the cavity so that the tip

-25-

is near the proximal end yet enclosed within the cavity, and

a resilient seal disposed within the cavity which covers said tip and is adapted to be moved into a compressed state upon insertion of the tip of the medical implement into said opening and an returns to an decompressed state upon removal of said tip,

5

said seal in the decompressed state having a section which fills essentially completely a portion of the cavity adjacent said opening, with said seal section bearing against said wall structure near said opening to seal said opening, and in the compressed state said seal section being pushed by the delivery end of the medical implement away from the opening and into the cavity,

10

said seal having a lip extending beyond the distal end and positioned between the first and second locking elements so that said lip provides an essentially fluid tight seal upon said locking elements interlocking.

40. The medical valve of Claim 39 where the spike has a substantially conical shape and the seal has a substantially conical shaped cavity therein conforming to the shape of the spike, said spike being disposed within said cavity with the seal covering said tip.

15

41. The medical valve of Claim 39 adapted to be use with a medical implement which transfers fluid through a tapered delivery end, said proximal end having an opening sufficiently large to receive said delivery end, and said wall structure tapering inward so that said wall structure and said tapered delivery end fit snug against each other upon insertion of the delivery end into the opening.

20

42. A medical valve including

a generally tubular body defining an internal cavity and having a proximal end and a distal end, said proximal end of said body having an opening sufficiently large to receive an ANSI standard tip of a medical implement,

25

a hollow spike having a closed tip, said spike including a plurality of holes located inward of said tip, said spike being seated inside the body such that said tip is inward of the proximal end of the body,

30

a support member connected to the spike which seals off a portion of the internal cavity of the body such that an upper cavity containing the tip of the spike is defined, and

a plastic, resilient silicone sealant which fills the upper cavity and covers the tip of the spike so as to present an essentially flush surface.

43. A valve for engaging a medical implement adapted to transfer fluid, comprising:

5 a hollow spike having a distal end and a proximal end, said spike having a tip at its proximal end and having at least 3 holes located inward of said tip, said holes being capable of being placed in fluid communication with said medical implement,

a seal adapted to fit over said spike and to reversibly seal said holes, said seal being adapted to reversibly unseal said holes when said medical implement is engaged with said connector valve; and

10 a housing at least partially containing said spike and said seal.

44. A method of transferring fluid from a remote source to a patient, including (a) connecting a medical valve to the patient where the valve includes a body including wall structure defining an internal cavity having a proximal end and a distal end,

15 said proximal end having an opening sufficiently large to receive a delivery end of a medical implement which transfers fluid through said delivery end,

a spike having a tip, at least one hole located at or near said tip, and a passageway in communication with the hole that allows fluid to flow through said hole,

20 said spike being seated inside the cavity such that said tip is enclosed within the cavity, and

25 a resilient seal which is adapted to be moved into a compressed state upon insertion of the tip of the medical implement into said opening and an returns to a decompressed state upon removal of said tip, said seal in the decompressed state having a section which fills essentially completely a portion of the cavity adjacent said opening, with said seal section bearing against said wall structure near said opening to seal said opening, and in the compressed state said seal section being pushed by the delivery end of the medical implement away from the opening and into the cavity; and

30 (b) inserting the delivery end of the medical implement into said opening and pushing said delivery end into the cavity to compress said seal sufficiently to allow said tip of the spike to enter said delivery end, whereby fluid is either transferred from the remote source to the patient.

45. The method of Claim 45 where fluid is transferred to the patient by

-27-

applying pressure the fluid as it passes through the implement so that pressure applied to the fluid is greater than the pressure of fluid in the patient, enabling transfer from the remote source to the patient.

5 46. The method of Claim 45 where the pressure of fluid in the patient is greater than the pressure at the remote source, enabling transfer from the patient to the remote source.

47. The method of Claim 45 where the valve is adapted for two-way communication to allow fluid to flow either into or from the patient.

10 48. A method of transferring fluid in a container having an open mouth covered by a cover member which seals said open mouth, including

(a) connecting a medical valve to the container where the valve includes a body including wall structure defining an internal cavity having a proximal end and a distal end,

15 said proximal end having an opening sufficiently large to receive a delivery end of a medical implement which transfers fluid through said delivery end.

a spike having a proximal tip, a distal tip, and a passageway placing said proximal tip and distal tip in communication with each other to allow fluid to flow through said passageway,

20 said spike being seated inside the cavity such that said proximal tip is inward of the proximal end and is enclosed within the cavity and said distal tip extends outward so that it pierces said cover member upon connecting the valve to the container,

25 a resilient seal which is adapted to be moved into a compressed state upon insertion of the tip of the medical implement into said opening and an returns to an decompressed state upon removal of said tip, said seal in the decompressed state having a section which fills essentially completely a portion of the cavity adjacent said opening, with said seal section bearing against said wall structure near said opening to seal said opening, and in the compressed state said seal section being pushed by the delivery end of the medical implement away from the opening and into the cavity; and

30

(b) inserting the delivery end of the medical implement into said opening and pushing said delivery end into the cavity to compress said seal sufficiently to allow said proximal tip of the spike to enter said delivery end, whereby fluid may be transferred from the container.

-28-

49. The method of Claim 49 where fluid is caused to flow from the container through the passageway by creating a differential in pressure.

50. The method of Claim 49 where the valve has an adaptor having a radial slit for allowing said adaptor to deform reversibly sufficiently to fit snugly onto said container.

51. A method of transferring a predetermined amount of medication from a remote source to a patient, including

(a) connecting a medical valve to the patient where the valve includes an opening sufficiently large to receive a delivery end of a medical implement which transfers said predetermined amount of medication through said delivery end into the valve, said valve including an enclosed spike with a tip having a hole therein and a resilient seal which is adapted to be moved into a compressed state by the delivery end upon insertion of said delivery end of the medical implement into said valve and an returns to a decompressed state upon removal of said delivery end to close said valve, said delivery end and said seal being adapted to engage so that the tip of the spike pierces the seal and there is essentially no dead space between said delivery end and the seal;

(b) inserting the delivery end of the medical implement into said valve and pushing said delivery end against said seal to compress said seal sufficiently to allow said tip of the spike to pierce the seal and enter said delivery end, said seal and delivery end engaging to eliminate essentially any dead space;

(c) transferring from the remote source to the patient directly through said valve essentially the entire predetermined amount of medication, so that essentially none of said predetermined amount is collected in any dead space in the valve; and

(d) withdrawing the delivery end of the medical implement from the valve to enable the seal to return to the decompressed state to close the valve and maintain while in said decompressed state a fluid tight seal even at high pressures and repeated uses.

52. A medical valve comprising:

a body including an internal cavity having a proximal end and a distal end, said proximal end having an opening sufficiently large to receive a delivery end of a medical implement which transfers fluid through said delivery end, a spike having a tip and a passageway with a hole that allows fluid to flow

through said passageway, and

a resilient seal which is adapted to be moved into a compressed state upon insertion of the tip of the medical implement into said opening to open the valve and an returns to a decompressed state upon removal of said tip to close said valve,

5

said seal being pierced by the spike upon being compressed and having a proximal end including a pressure responsive element disposed on an inner surface of the seal adjacent said opening, said pressure responsive element in the decompressed state closing any orifice in the seal at said proximal end to provide an essentially fluid-tight seal while in the decompressed state.

10

53. The medical valve of Claim 52 where the pressure responsive element is a section of the seal including an entryway into a precut orifice in the proximal end of the seal, said seal section being surrounded by a space which receives pressurized fluid.

54. The medical valve of Claim 52 where said tip has a plurality of facets which meet within a recess.

15

55. The medical valve of Claim 52 where the seal comprises a series of O-ring elements stacked together and connected to form a unitary structure.

56. The medical valve of Claim 54 where the O-ring elements have increasing diameters, with the smallest diameter element being adjacent a proximal end of the seal.

20

57. The medical valve of Claim 52 where there is a cavity in said body having a plurality of radial indentations in an interior wall that is adjacent the seal to accommodate the expansion of the seal upon compression of said seal.

58. The medical valve of Claim 52 where the delivery end and the seal are adapted to engage so that when the tip of the spike pierces the seal there is essentially no dead space between said delivery end and the seal.

25

59. The medical valve of Claim 52 where the proximal end of the seal has a centrally located, anti-vacuum, saucer like depression therein, and the pressure responsive element has an anti-tear element.

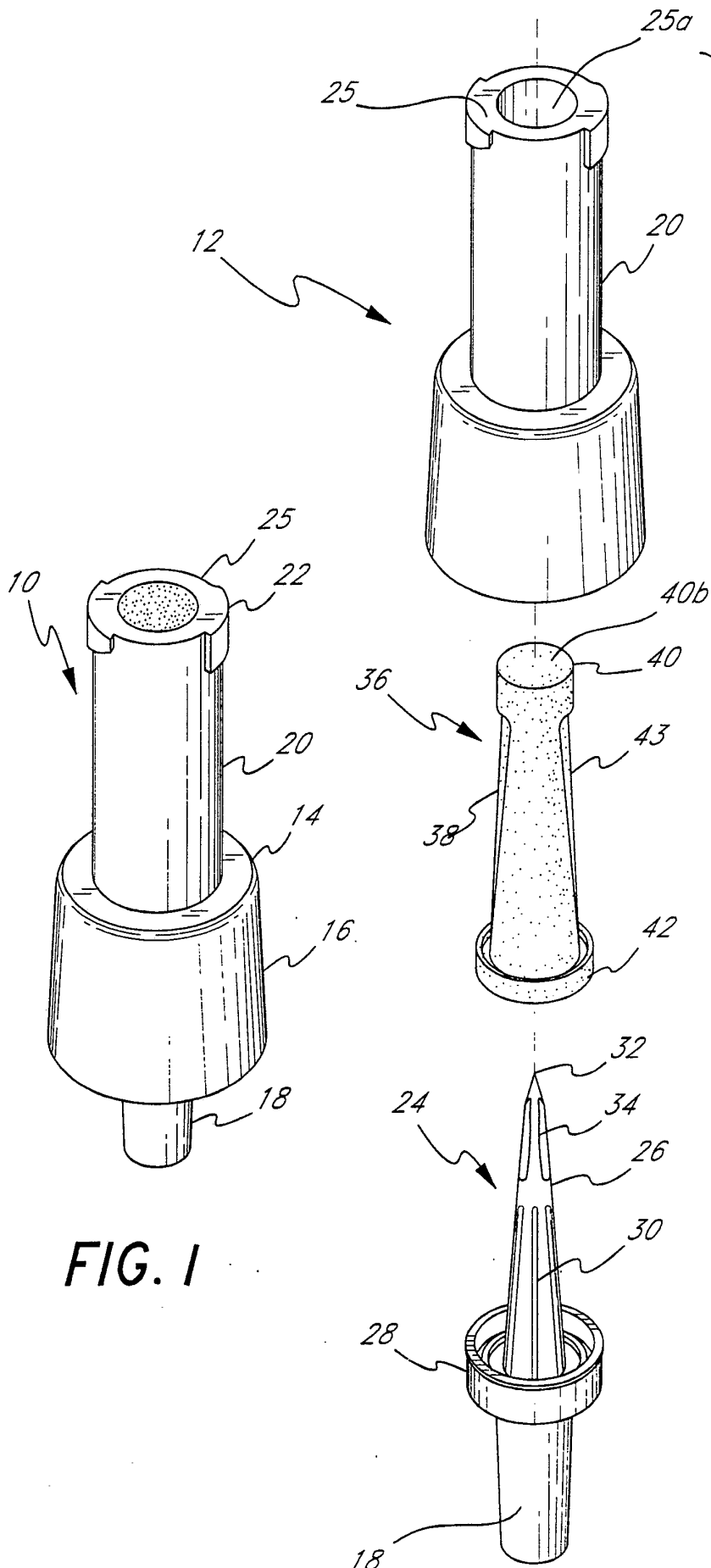

FIG. 1

FIG. 2

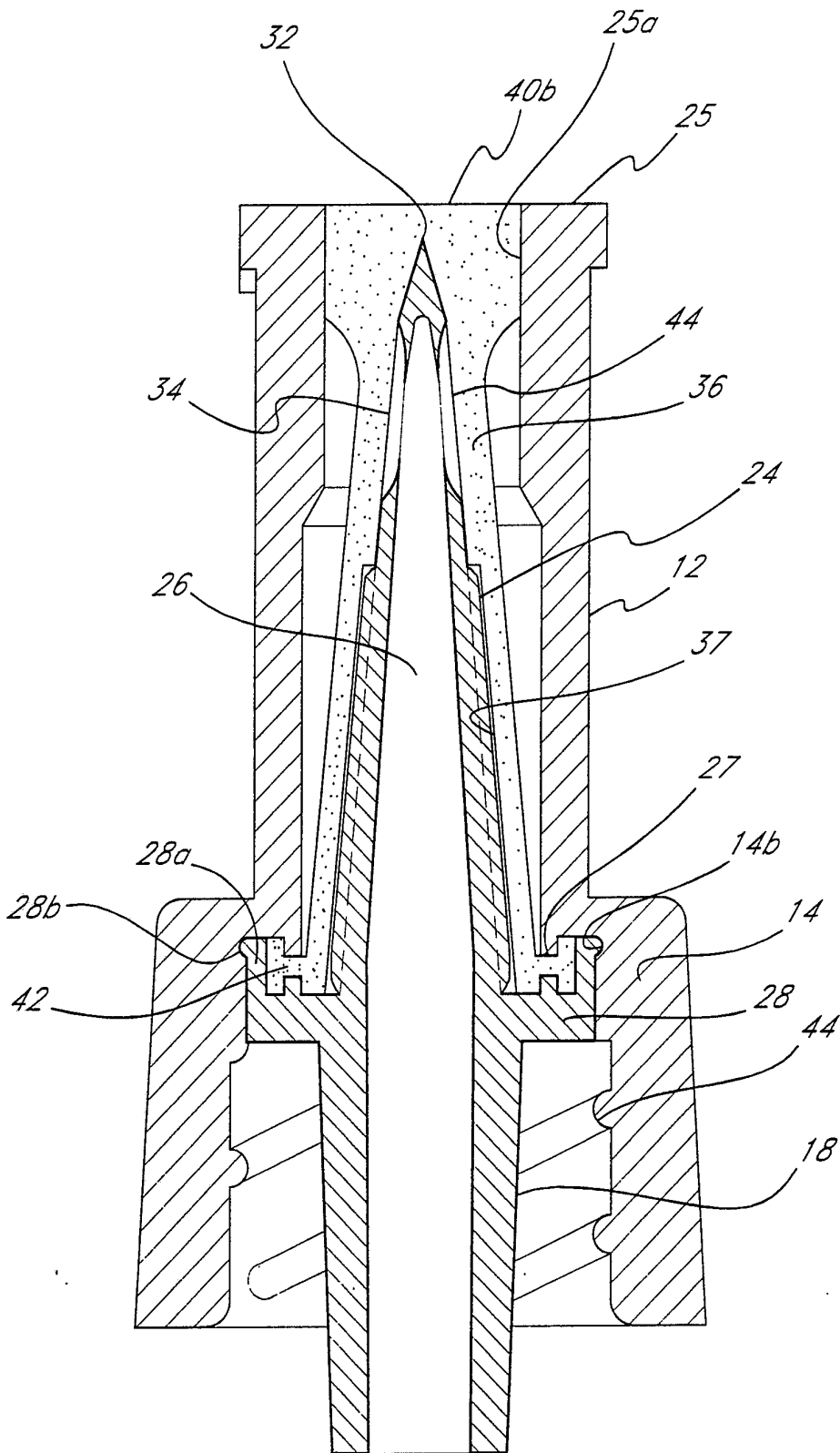

FIG. 3

SUBSTITUTE SHEET

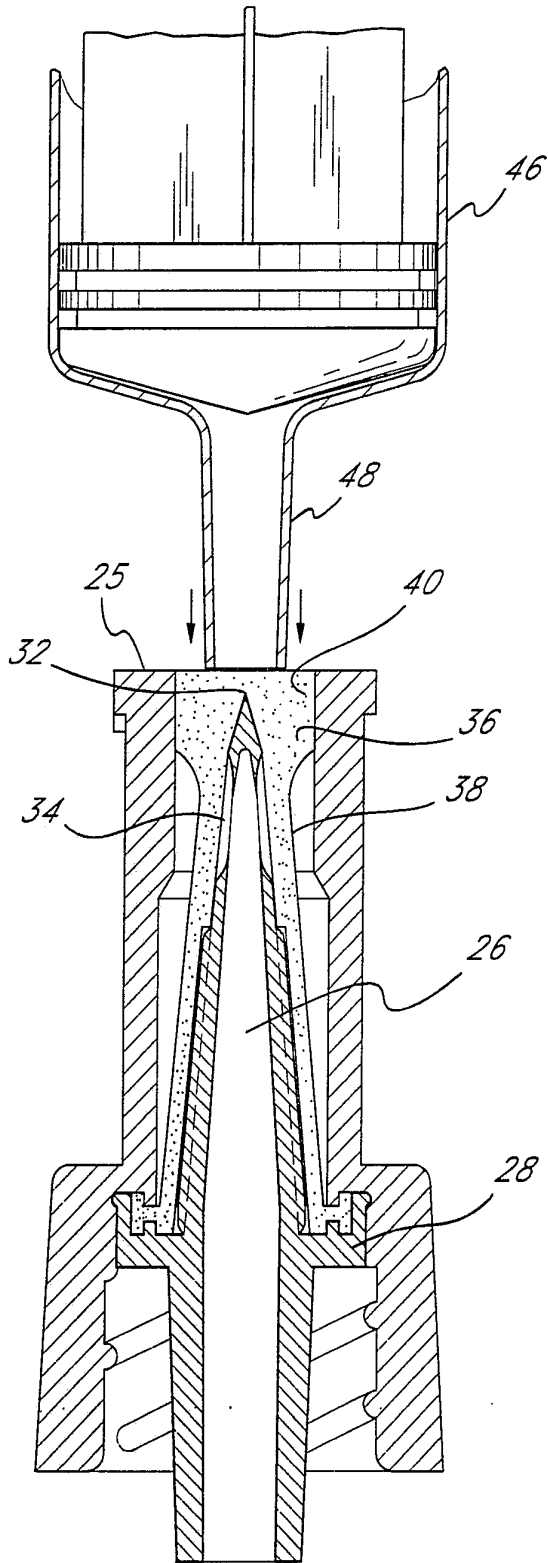

FIG. 4

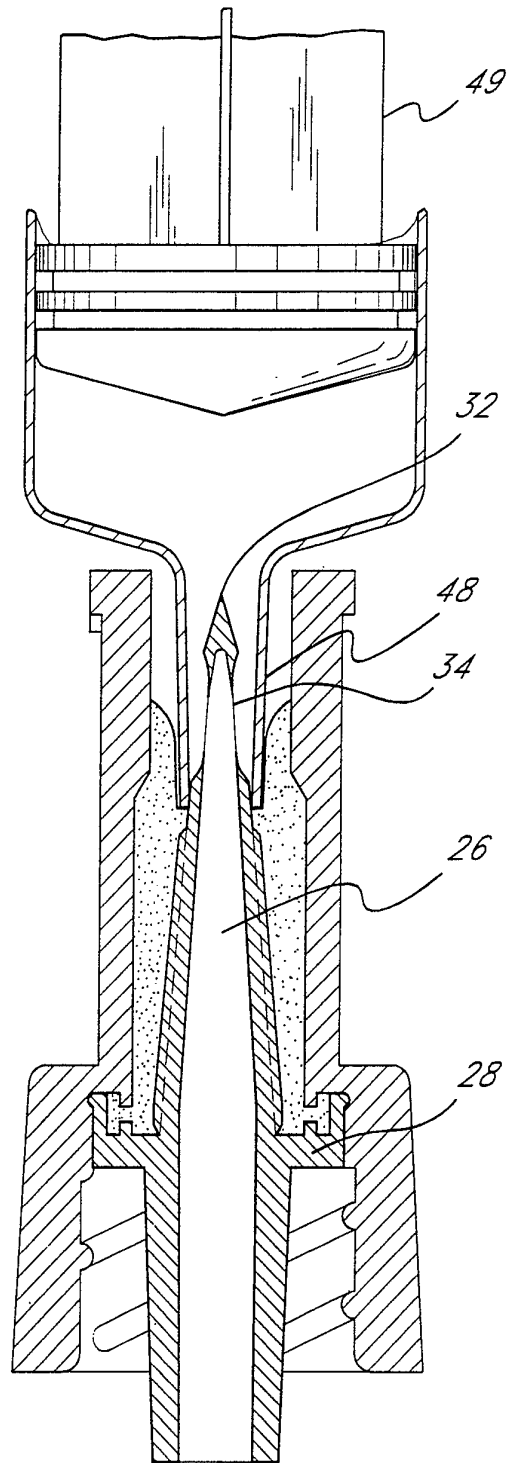

FIG. 5

FIG. 6

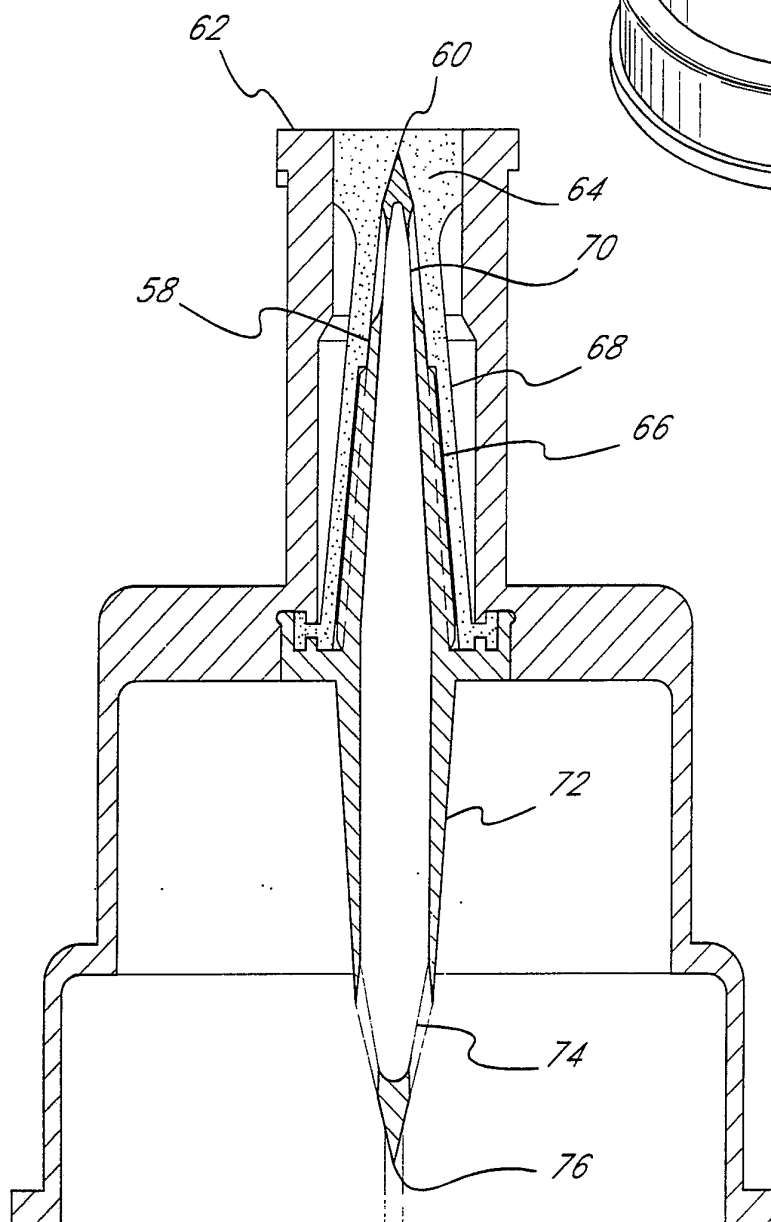
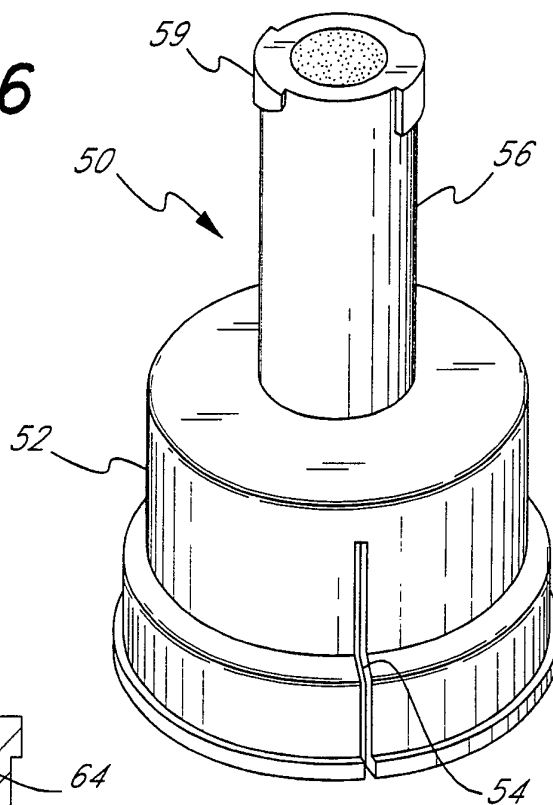
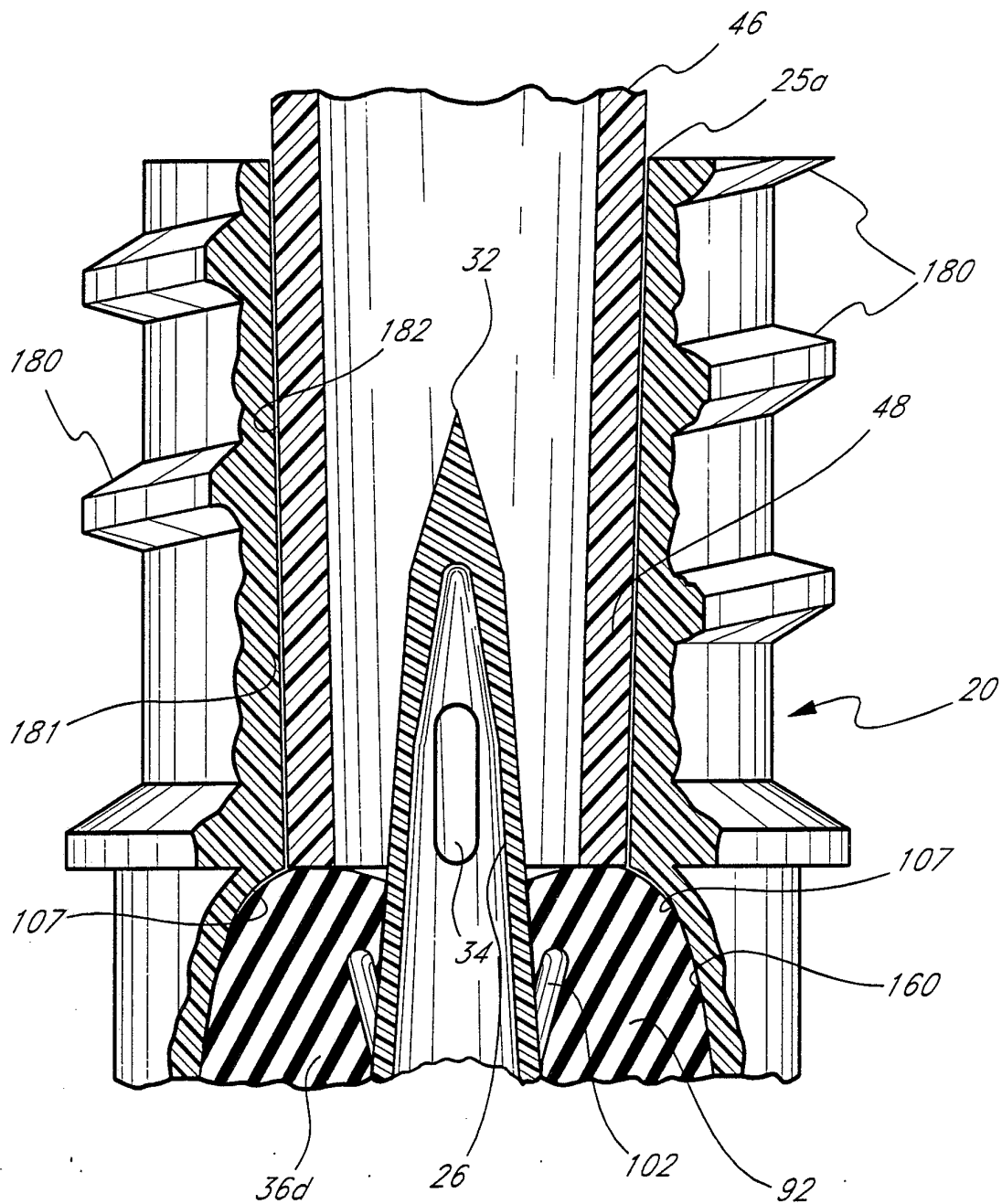

FIG. 7

FIG. 8



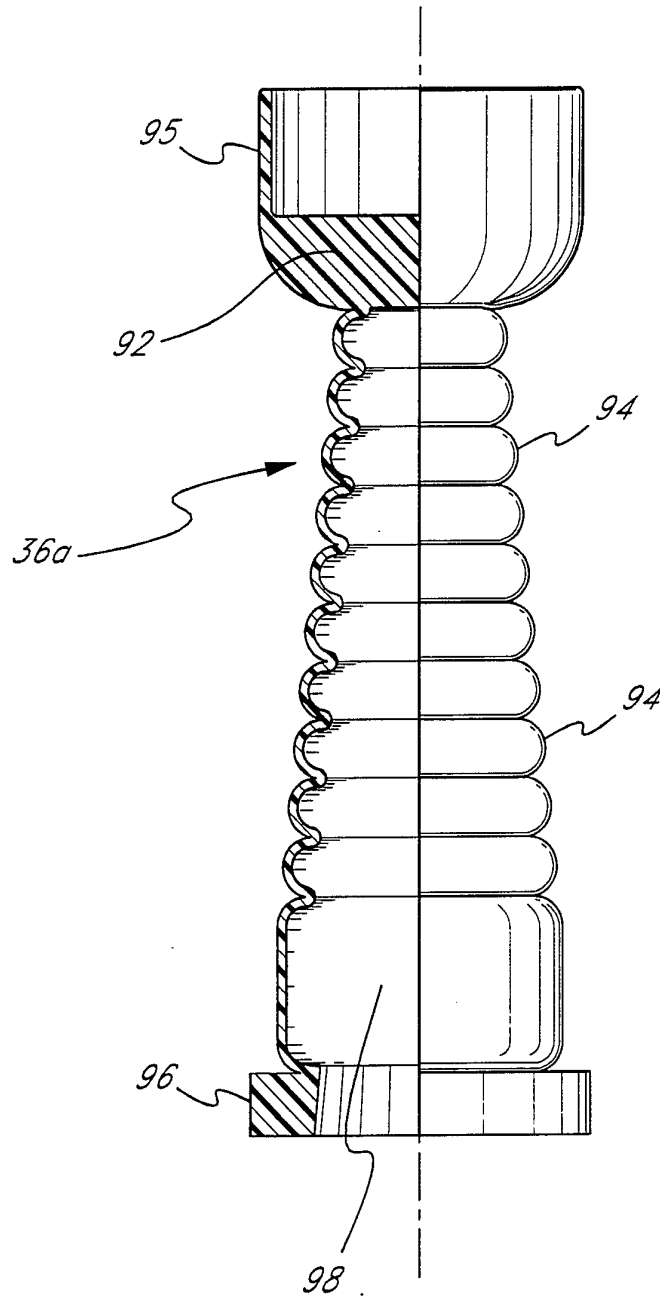

FIG. 9

7/19

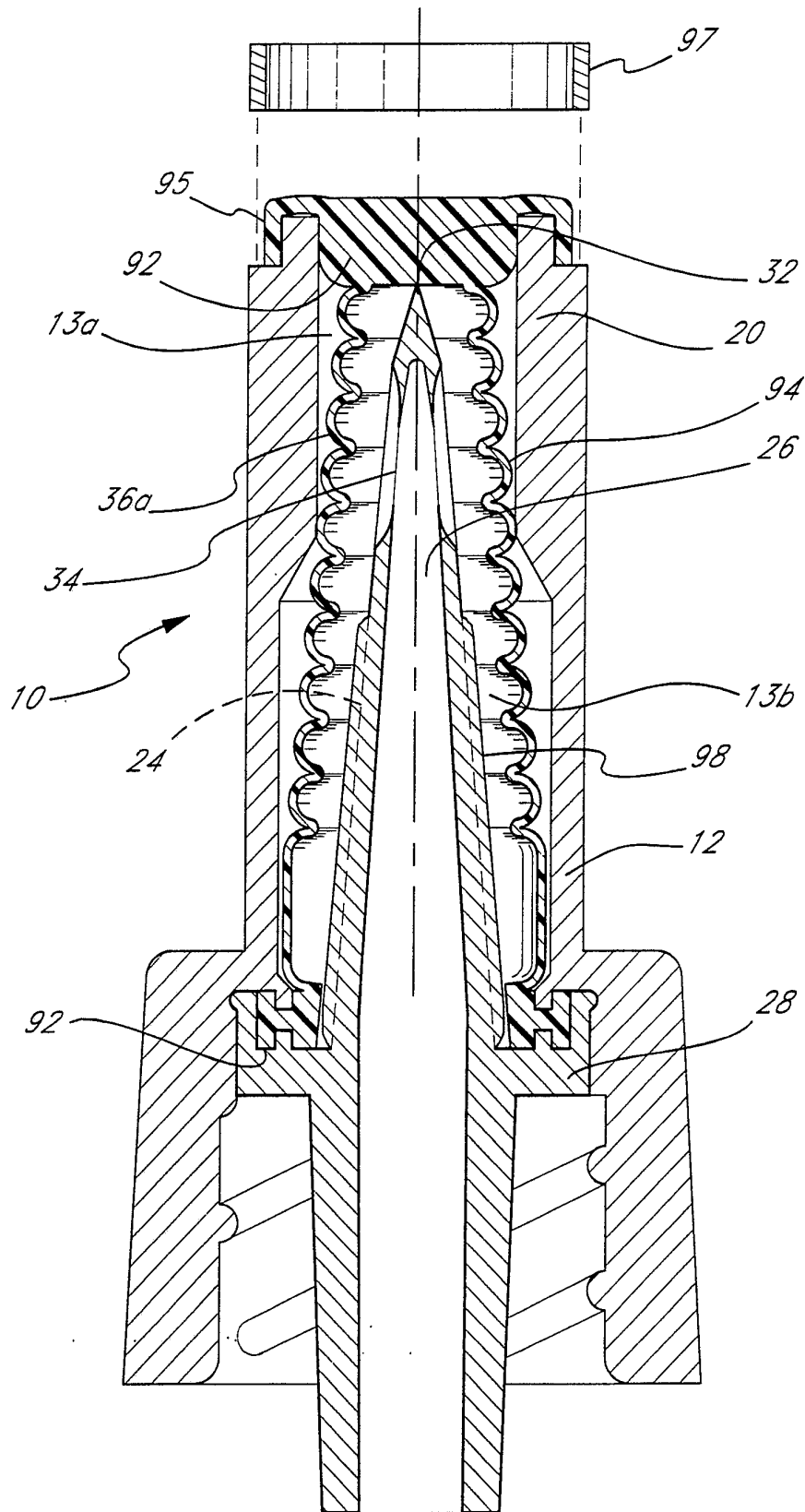

FIG. 10

SUBSTITUTE SHEET

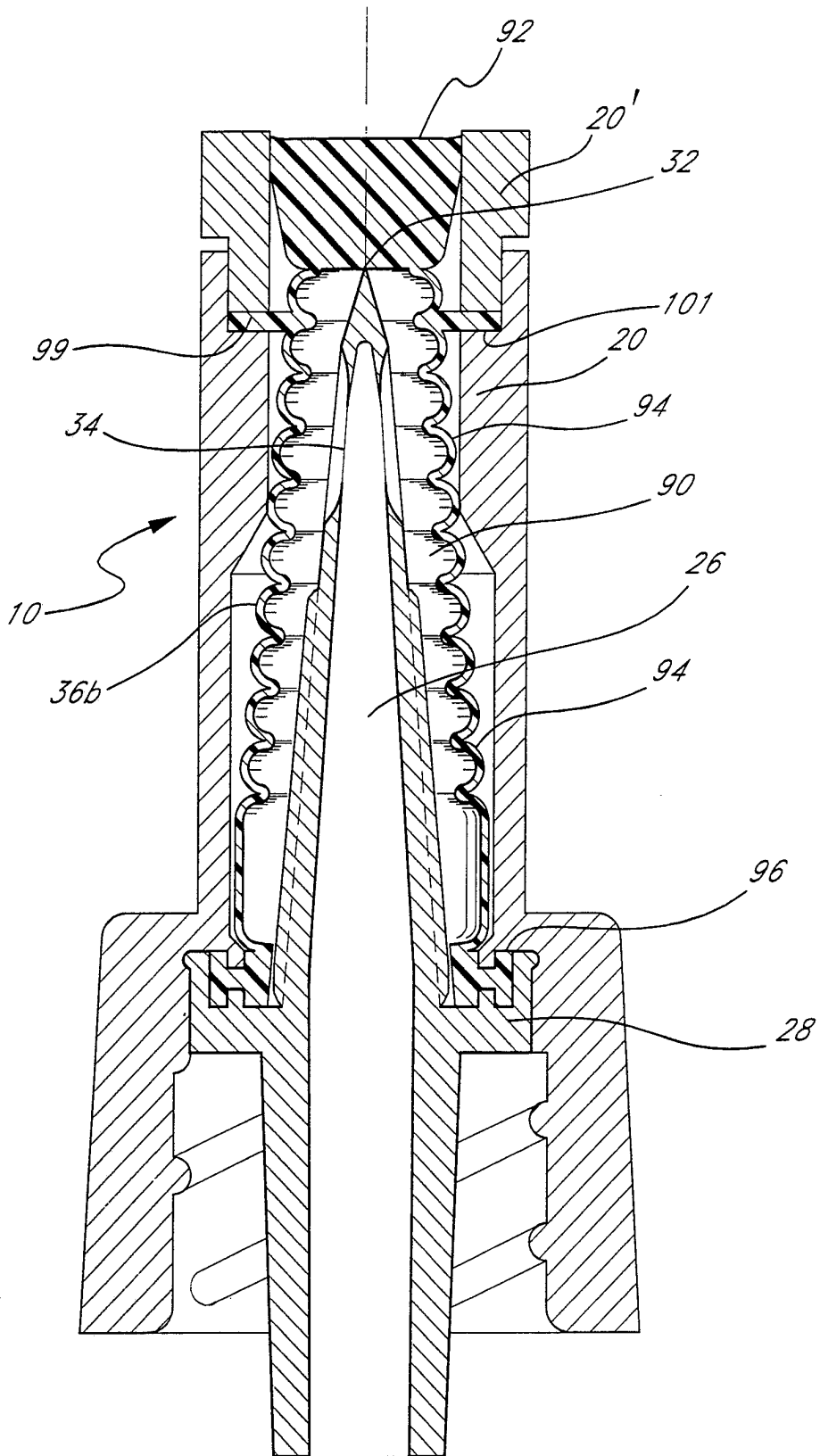

FIG. 11

SUBSTITUTE SHEET

9/19

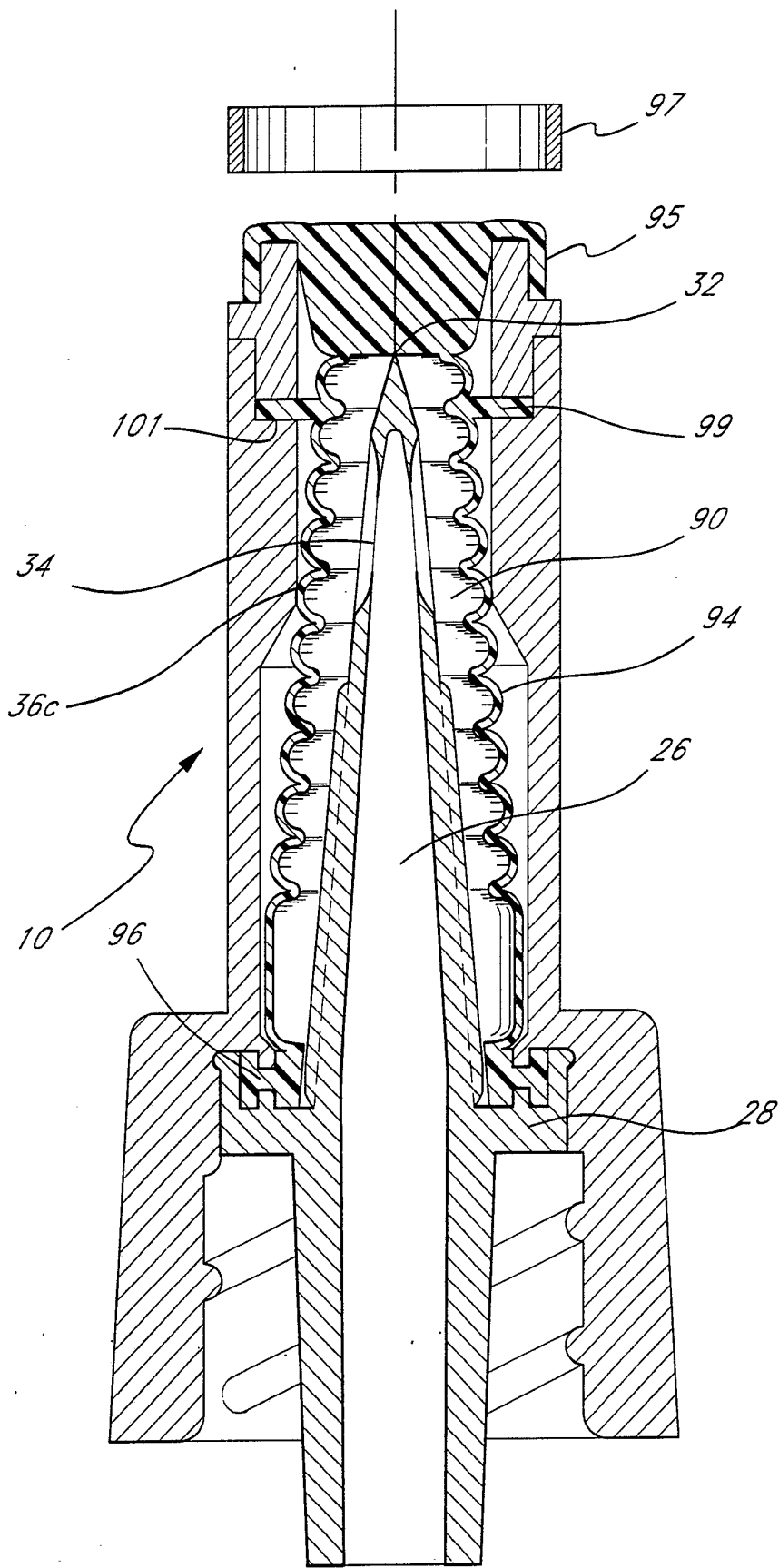

FIG. 12

SUBSTITUTE SHEET

10/19

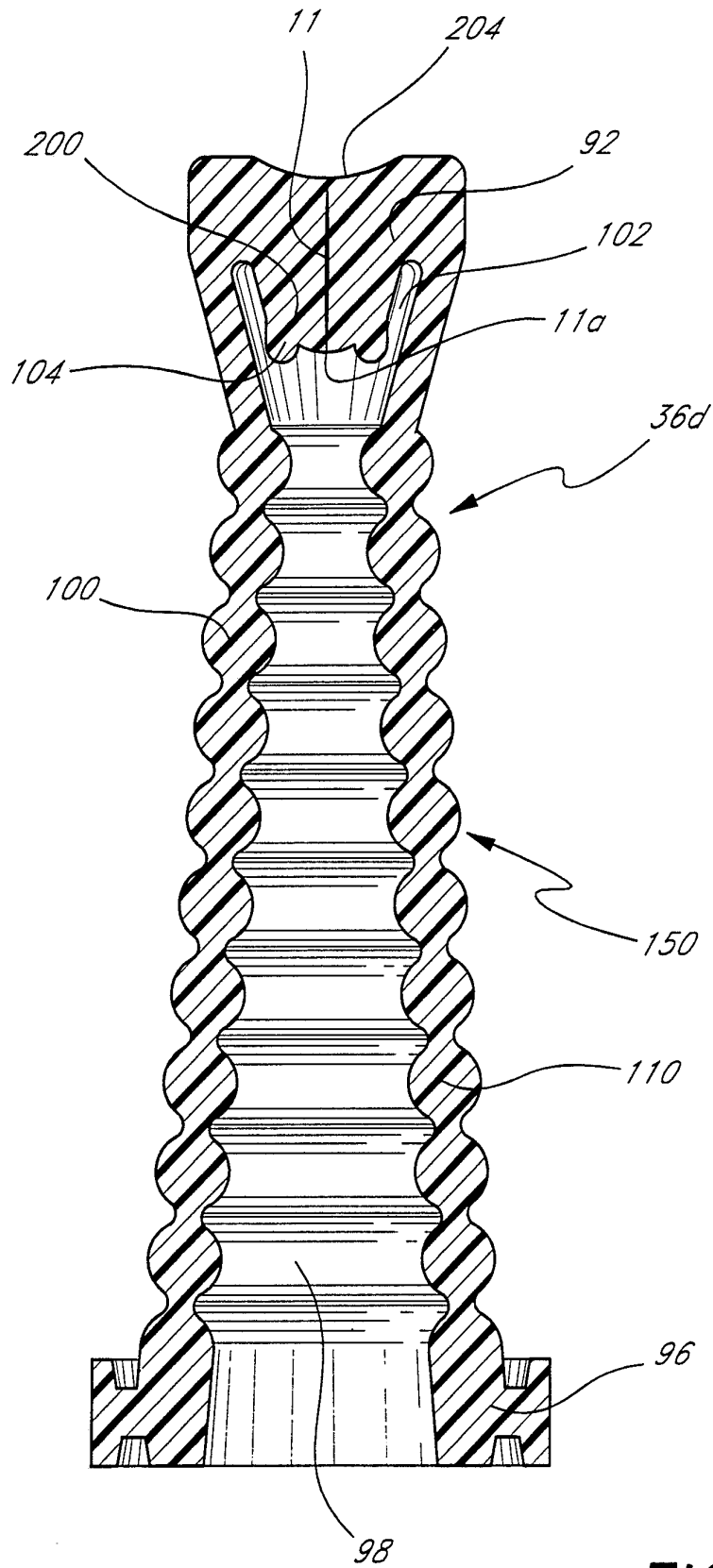

FIG. 13

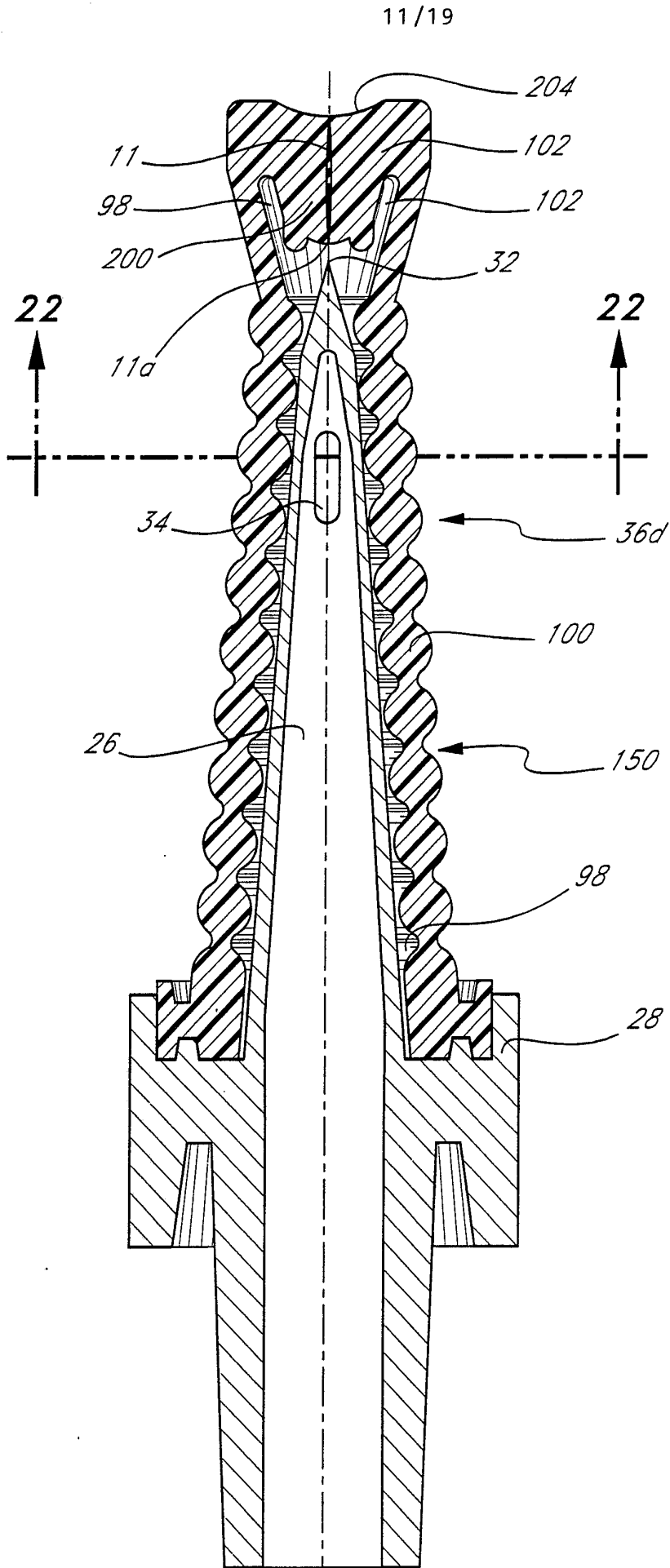

FIG. 14

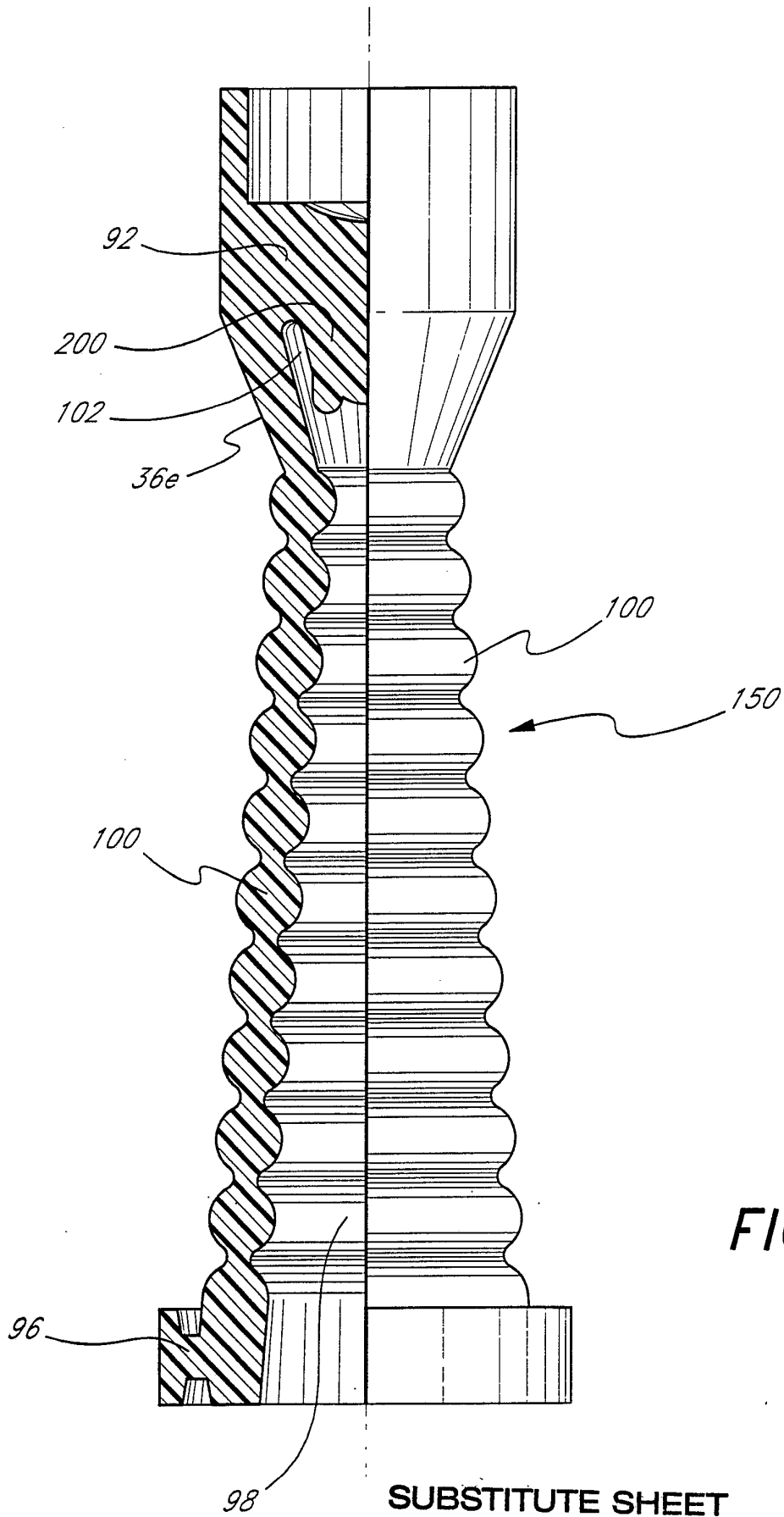

FIG. 15

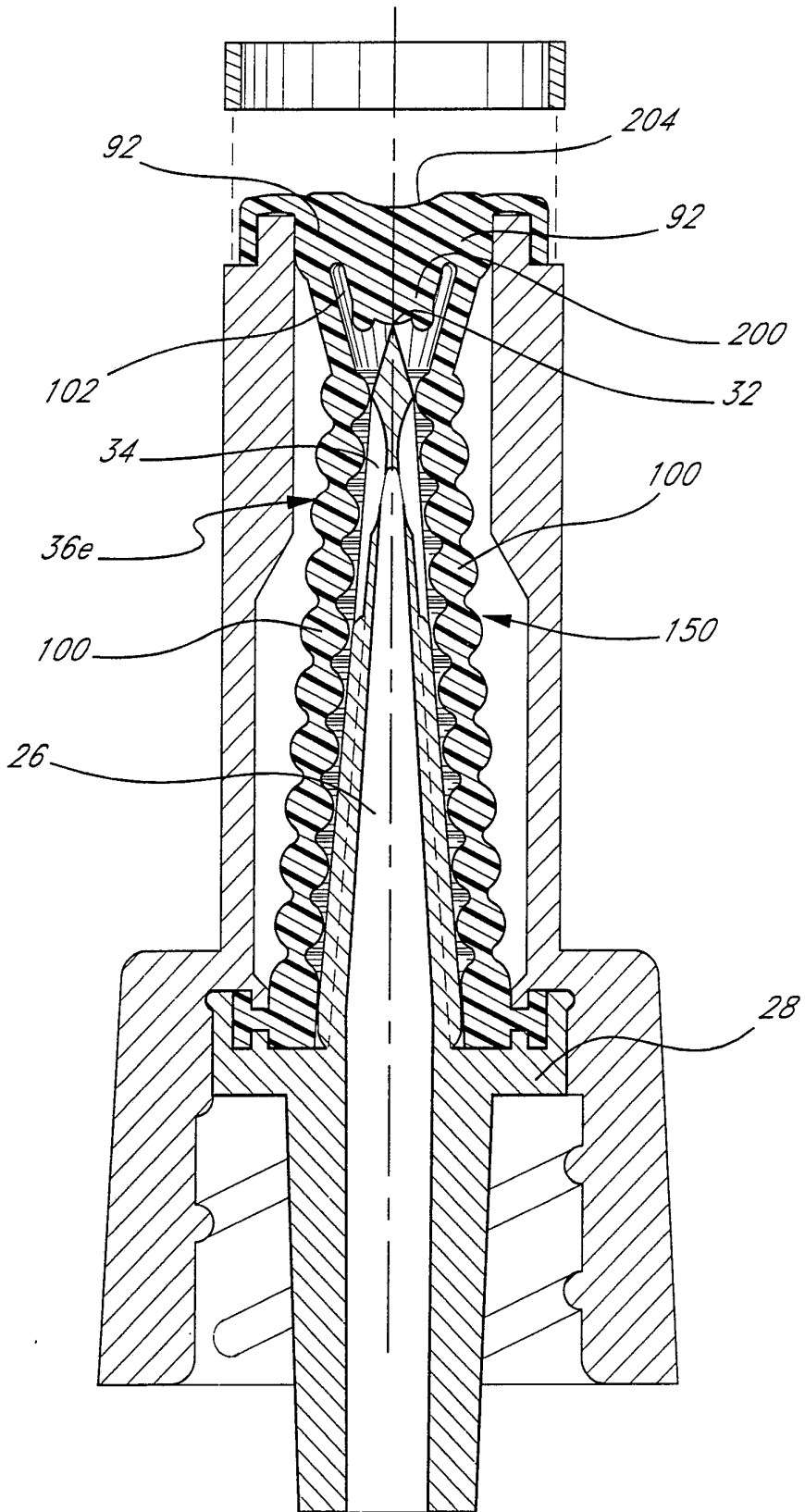

FIG. 16

SUBSTITUTE SHEET

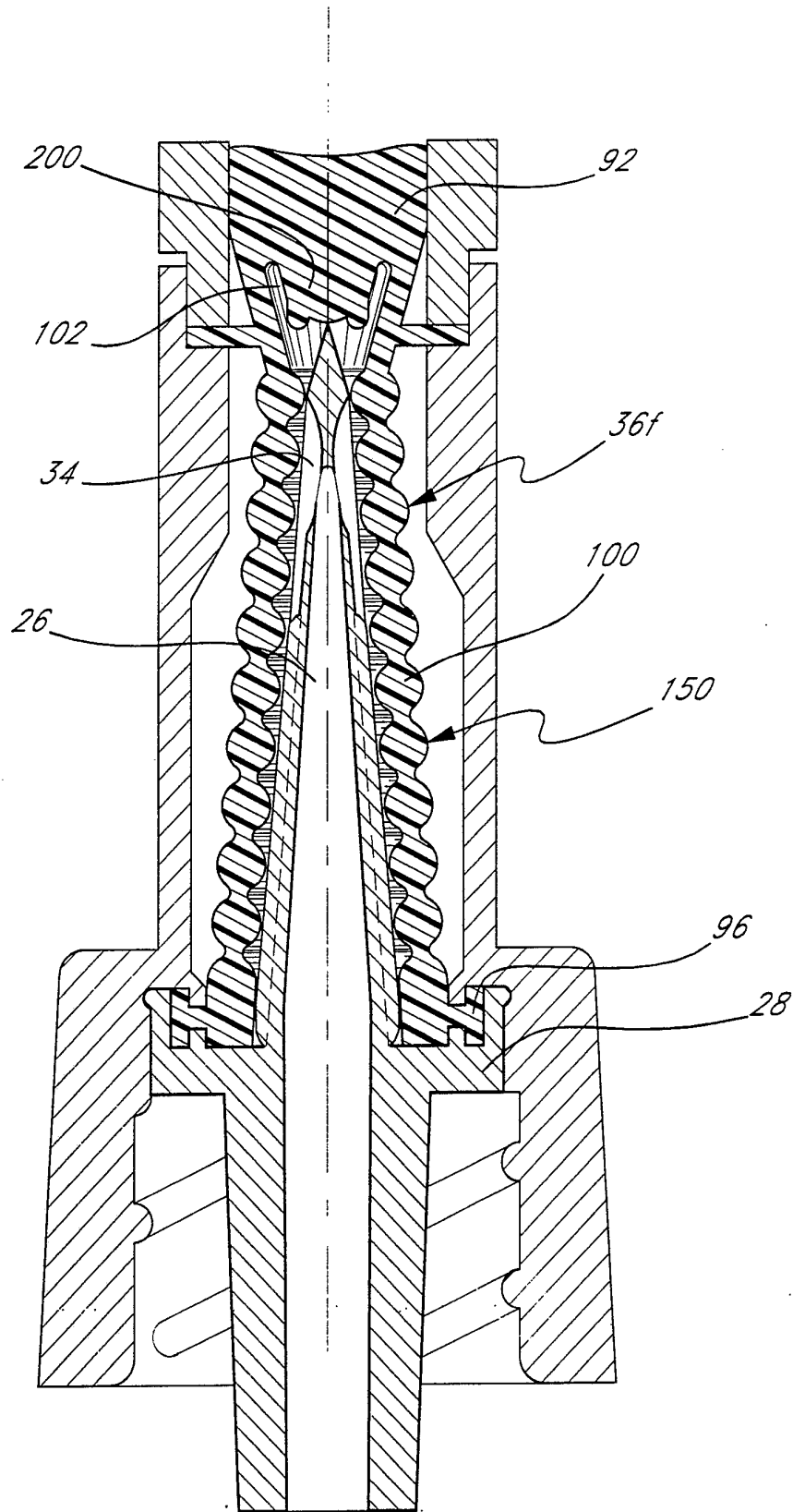

FIG. 17

SUBSTITUTE SHEET

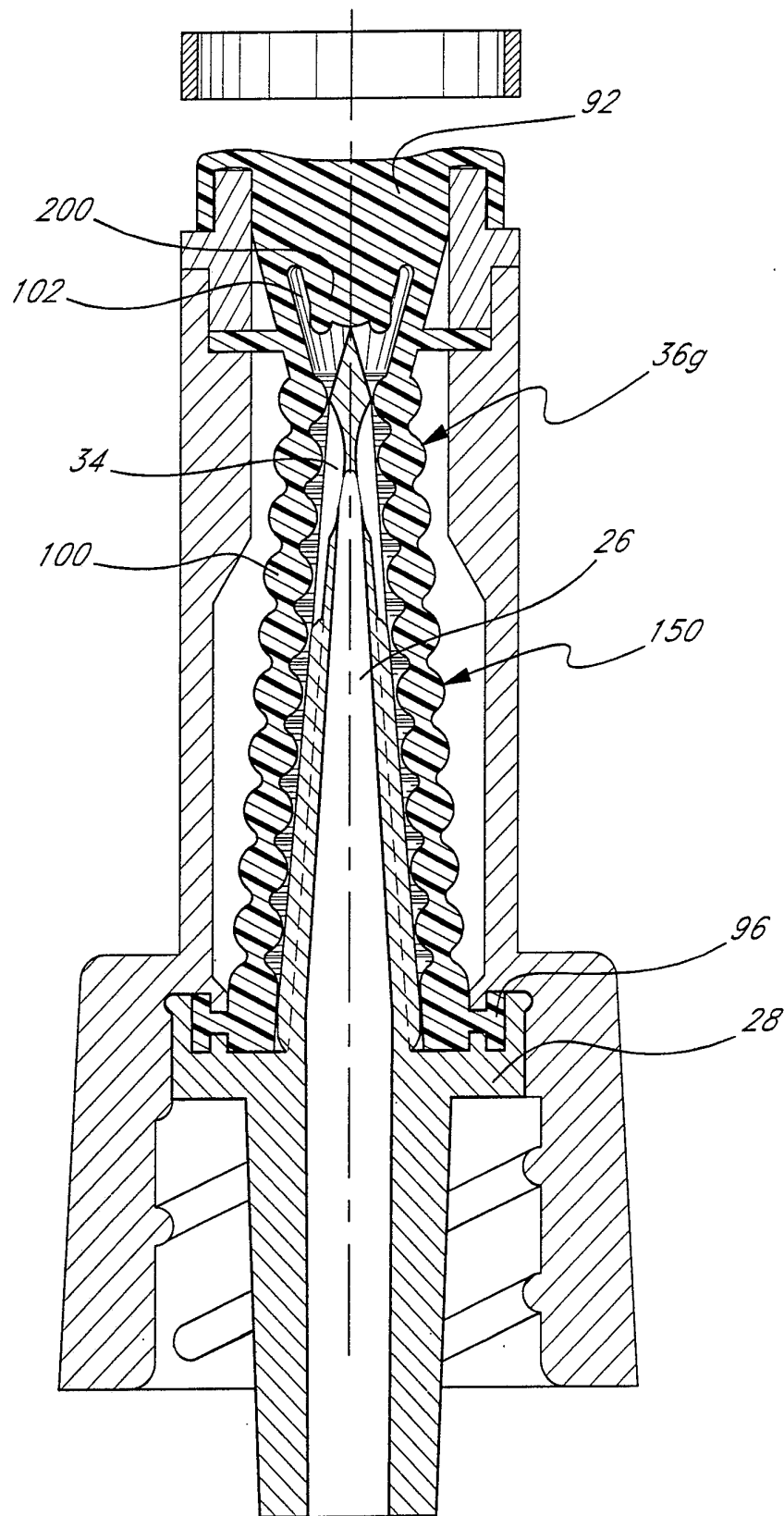

FIG. 18

SUBSTITUTE SHEET

FIG. 19

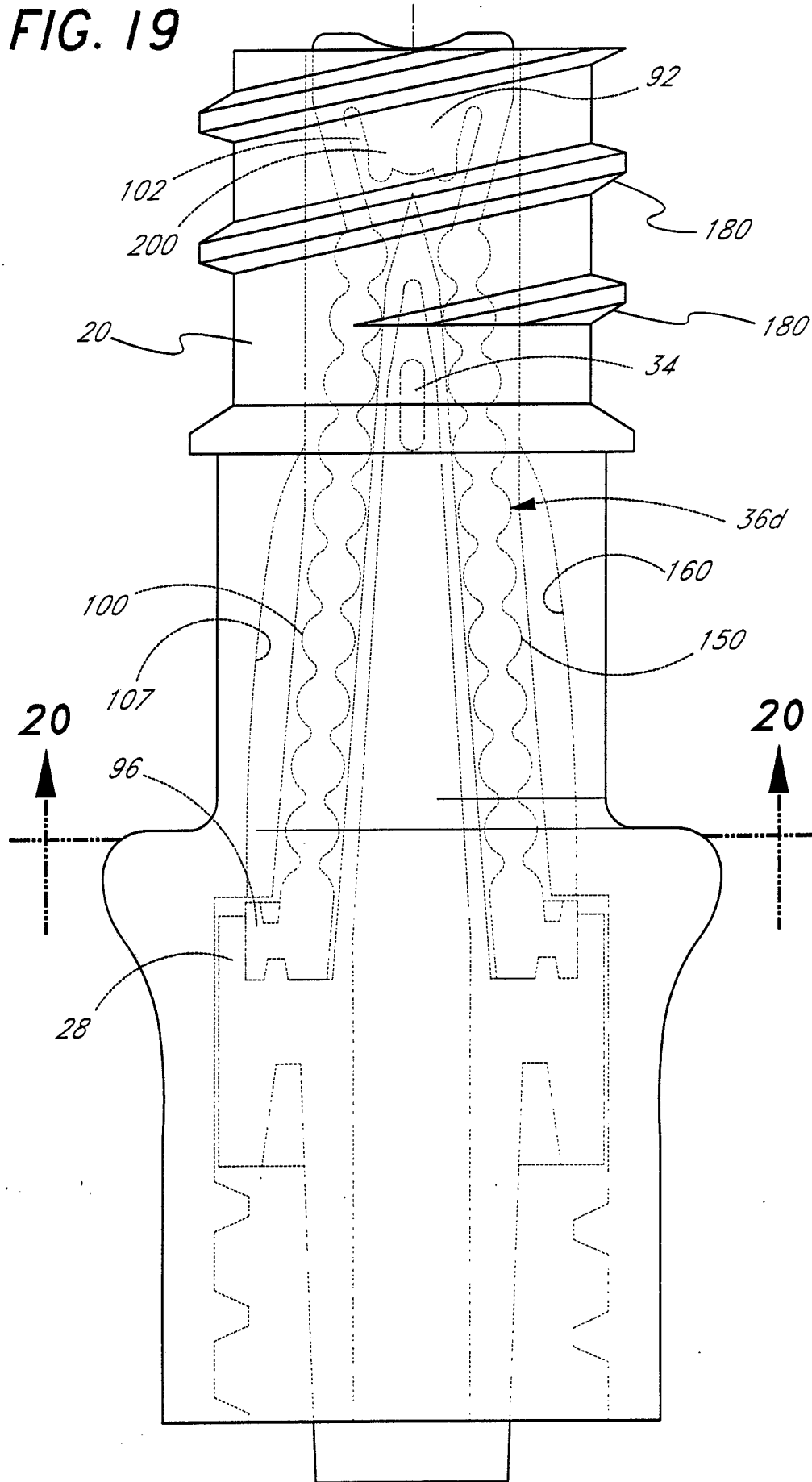
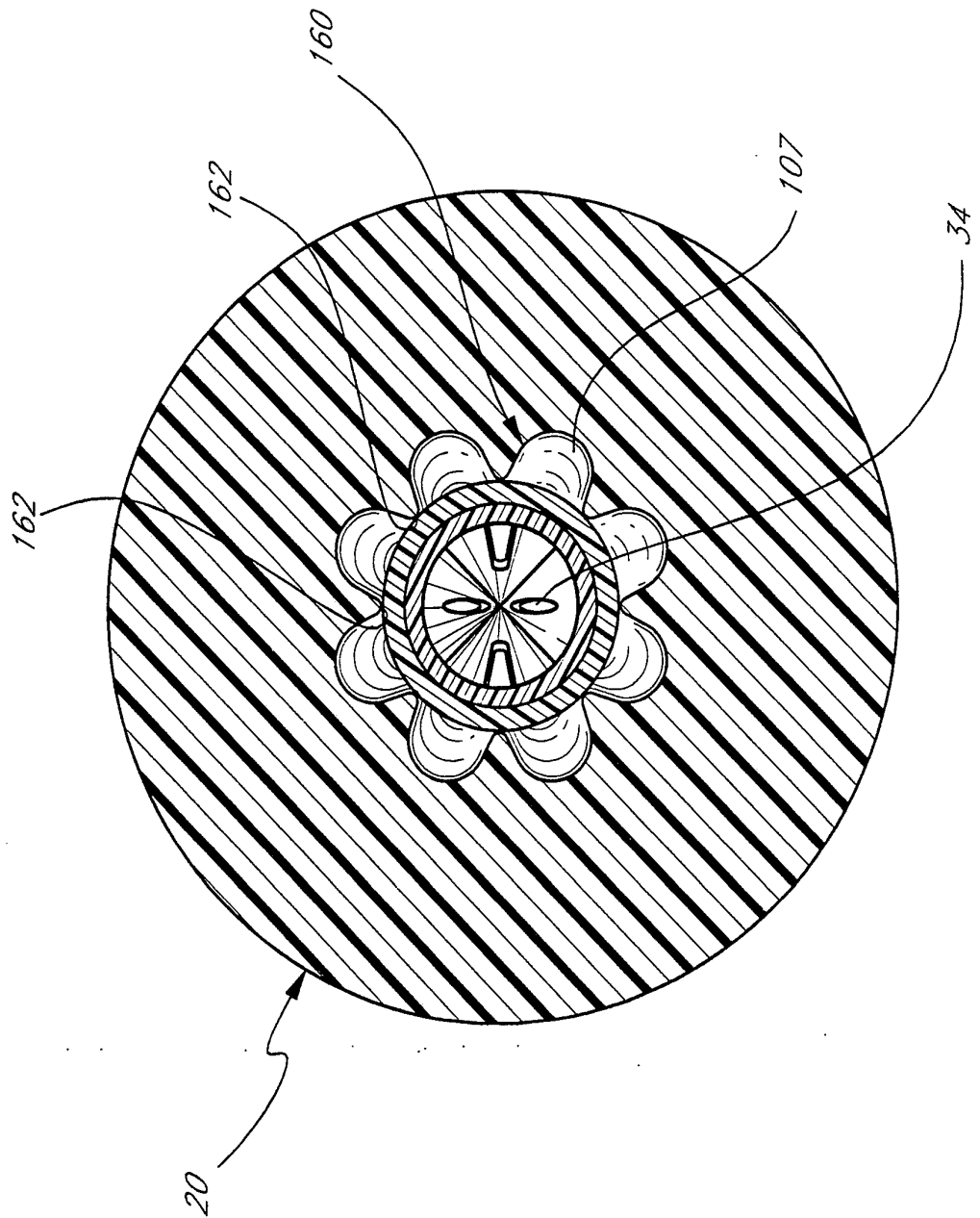
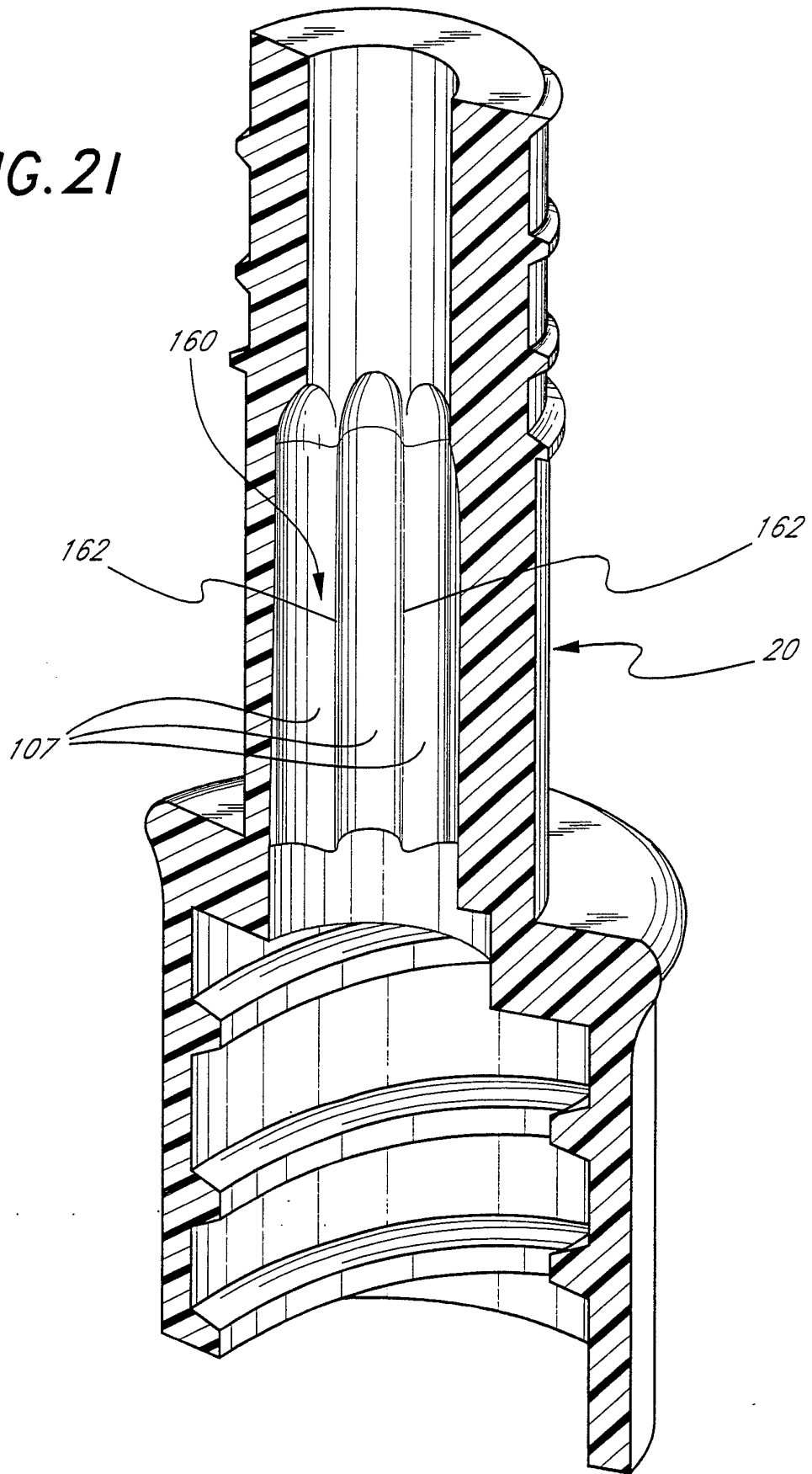

FIG. 20



SUBSTITUTE SHEET

FIG. 21



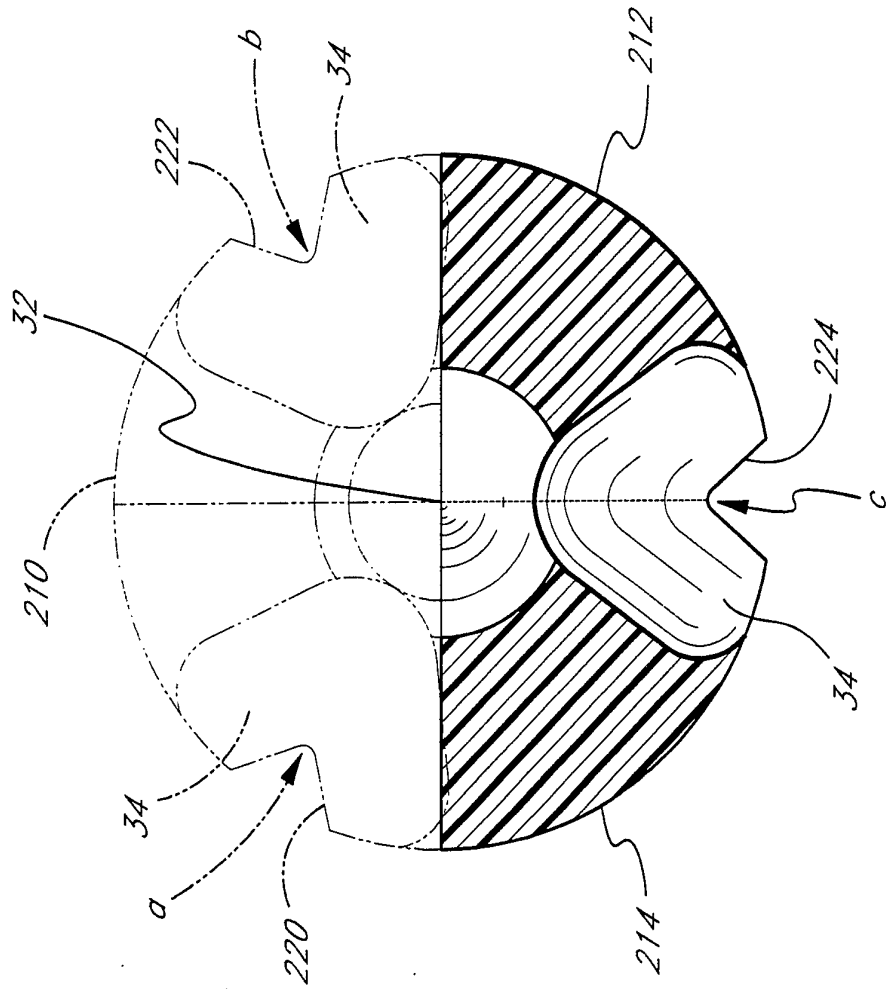

FIG. 22

INTERNATIONAL SEARCH REPORT

PCT/US 92/10367

International Application No

I. CLASSIFICATION OF SUBJECT MATTER (if several classification symbols apply, indicate all) ⁶		
According to International Patent Classification (IPC) or to both National Classification and IPC Int.Cl. 5 A61M39/00		
II. FIELDS SEARCHED		
Minimum Documentation Searched ⁷		
Classification System	Classification Symbols	
Int.Cl. 5	A61M	
Documentation Searched other than Minimum Documentation to the Extent that such Documents are Included in the Fields Searched ⁸		
III. DOCUMENTS CONSIDERED TO BE RELEVANT⁹		
Category ¹⁰	Citation of Document, ¹¹ with indication, where appropriate, of the relevant passages ¹²	Relevant to Claim No. ¹³
X	EP,A,0 309 771 (JOKA KATHETERTECHNIK GMBH) 5 April 1989 see the whole document ---	1-4, 8, 9, 12-17, 21, 22, 25, 26, 32, 33, 42-53, 57
X	DE,U,8 425 197 (MAGASI) 19 September 1985 see the whole document ---	1, 2, 13, 14, 15, 26, 43-53
X	US,A,4 645 494 (LEE ET AL) 24 February 1987	43
A	see column 4, line 60 - column 5, line 28; figures ---	1-42, 44-59
-/--		
<p>¹⁰ Special categories of cited documents:</p> <p>"A" document defining the general state of the art which is not considered to be of particular relevance</p> <p>"E" earlier document but published on or after the international filing date</p> <p>"L" document which may throw doubts on priority claim(s) or which is cited to establish the publication date of another citation or other special reason (as specified)</p> <p>"O" document referring to an oral disclosure, use, exhibition or other means</p> <p>"P" document published prior to the international filing date but later than the priority date claimed</p> <p>"T" later document published after the international filing date or priority date and not in conflict with the application but cited to understand the principle or theory underlying the invention</p> <p>"X" document of particular relevance; the claimed invention cannot be considered novel or cannot be considered to involve an inventive step</p> <p>"Y" document of particular relevance; the claimed invention cannot be considered to involve an inventive step when the document is combined with one or more other such documents, such combination being obvious to a person skilled in the art.</p> <p>"&" document member of the same patent family</p>		
IV. CERTIFICATION		
Date of the Actual Completion of the International Search	Date of Mailing of this International Search Report	
02 MARCH 1993	22.03.93	
International Searching Authority	Signature of Authorized Officer	
EUROPEAN PATENT OFFICE	CLARKSON P.	

III. DOCUMENTS CONSIDERED TO BE RELEVANT (CONTINUED FROM THE SECOND SHEET)		Relevant to Claim No.
Category ^a	Citation of Document, with indication, where appropriate, of the relevant passages	
A	US,A,4 334 551 (PFISTER) 15 June 1982 see the whole document -----	1-59

**ANNEX TO THE INTERNATIONAL SEARCH REPORT
ON INTERNATIONAL PATENT APPLICATION NO.**

US 9210367
SA 67998

This annex lists the patent family members relating to the patent documents cited in the above-mentioned international search report. The members are as contained in the European Patent Office EDP file on The European Patent Office is in no way liable for these particulars which are merely given for the purpose of information. 02/03/93

Patent document cited in search report	Publication date	Patent family member(s)	Publication date
EP-A-0309771	05-04-89	DE-A- 3732515 DE-A- 3870379	06-04-89 27-05-92
DE-U-8425197	19-09-85	None	
US-A-4645494	24-02-87	EP-A,B 0220911	06-05-87
US-A-4334551	15-06-82	None	