

April 16, 1935.

H. FORTH

1,997,635

RETAINING MEMBER FOR TEMPORARY BINDERS

Filed July 31, 1934

Fig. 1.

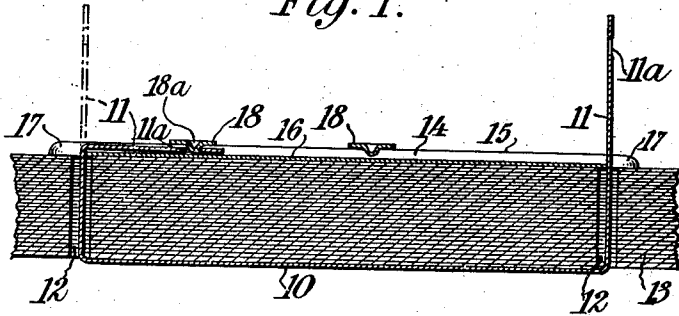

Fig. 2.

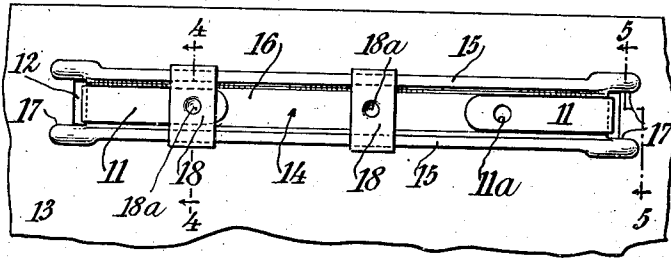

Fig. 4.

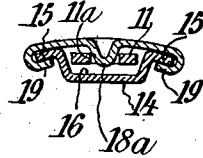

Fig. 3.

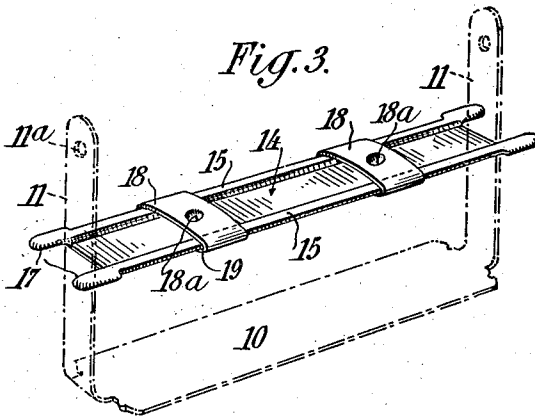
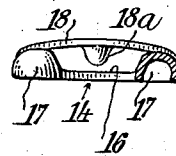

Fig. 5.



INVENTOR
Herman Forth,
BY
Draser, Myers & Mauley,
ATTORNEYS.

UNITED STATES PATENT OFFICE

1,997,635

RETAINING MEMBER FOR TEMPORARY BINDERS

Herman Forth, New York, N. Y., assignor to The Cooke & Cobb Company, Brooklyn, N. Y., a corporation of New York

Application July 31, 1934, Serial No. 737,691

5 Claims. (Cl. 24—153)

My present invention relates to fasteners intended for use to secure papers, correspondence, documents, etc. for filing, and aims to provide certain improvements therein. More particularly it relates to the type of fastener which has a pair of prongs or tongues which pass through spaced perforations in the papers to be secured, and which tongues are adapted to be bent down over a retaining element or keeper and held there-
 10 against by locking means.

In most of the fasteners of the type set forth in commercial use at present the tongues must be threaded through eyes or openings in the retaining element, a procedure which is time-consuming even when the tongues are smooth, and which
 15 procedure becomes more time-consuming and difficult after the fastener has been in use and the tongues have become wrinkled and humped due to repeated opening and closing of the fastener and the bending of the tongues at different points thereof.

The primary objects of my present invention are to increase the speed and efficiency with which such fasteners can be used and to generally improve the construction thereof.

The foregoing and other objects of my invention not specifically set forth, I accomplish by forming each end of the retaining member with a notch or as a fork extending longitudinally thereof, whereby the retaining member is enabled
 25 to fall into position between the tongues, be they perfectly smooth or wrinkled. I also propose to reinforce the ends of the retaining member at the sides of the notches to add rigidity to the device and to give the whole a flat bearing upon the papers to be fastened. I propose further to provide cooperating latching means between the
 30 tongues and the locks to hold said tongues in position after being bent down over the retaining member.

The invention will be better understood from a consideration of the accompanying drawing showing a preferred embodiment thereof, and wherein—

45 Figure 1 is a longitudinal section through a temporary binder embodying my invention.

Fig. 2 is a top plan view of the binder shown in Fig. 1.

50 Fig. 3 is a perspective view of the retaining member showing its manner of application to the tongued elements of the binder.

Fig. 4 is a section taken substantially along the plane of the line 4—4 of Fig. 2;

55 Fig. 5 is a section taken substantially along the broken line 5—5 of Fig. 2, the binder elements

other than the retaining element thereof being omitted.

Referring to the drawing, the numeral 10 indicates the base of the fastener which has spaced prongs or tongues 11 formed integrally therewith and normally extending at right angles to the base and adapted to pass through perforations 12 in the papers 13 which are intended to be bound by the fastener. The tongues 11 are of a length to normally project through the mass of sheets 13 and to be bent down over a retaining member or keeper 14. The present invention is primarily directed to the character and construction of retaining member 14 and to the manner in which it cooperates with the tongues 11.

The retaining member 14 consists of an elongate relatively flat element which may be formed of metal, compressed fiber or other suitable material, the said element having its longitudinal edges bent upwardly and outwardly to provide rails 15 and a longitudinal channel 16 between said rails. The element 14 at each end is formed with a notch or fork 17 of a width slightly greater than that of the tongues 11 so as to readily receive the latter, the inner wall of said notches or prongs being preferably straight and forming substantially a right angle with the side walls of the notches and providing a bearing over which the tongues 11 can be bent. The portions of the element flanking the notches or forming the tines of the fork are preferably bevelled or turned downwardly and are of a thickness or height such that the bases thereof lie in a common plane with the underside of the element 14 at the base of the channel 16, as best shown in Fig. 5. The purpose of having the bottoms of the forks and the under side of the channelled element in a common plane is to provide a flat bearing for the element and thus preclude rocking thereof while bending the tongues thereover. The rails and bevelled or bent down portions at the forks also serve to render the retaining member more rigid and thereby not so susceptible to accidental deformation.

Bridging the channel of the retaining member and carried by and movable over the rails, is a pair of locks 18, the lateral edges 19 of which engage around the edges of the rails, as best shown in Fig. 4. Preferably the engagement of these lateral edges around the rails is such that the lower portions thereof are disposed above the plane of the bottom of the flat channel portion 14 so as not to contact with the papers over which said retaining member is applied. Free movement of the locks over the rails is thus pro-

vided for and all danger of tearing the papers due to engagement of the locks therewith is avoided. To prevent the locks from moving longitudinally off of the retaining member, the 5 forked portions thereof are made slightly wider than the width of the retaining member at the rails.

In practice it has been found desirable to latch the locks over the tongues after they have been 10 bent down into the channel, and to accomplish this I have found that a very efficient latch can be provided by forming perforations 11a adjacent the ends of the tongues and forming the locks with inwardly directed detents or projec- 15 tions 18a adapted to engage in the openings 11a, as best shown in Fig. 4. Due to the resiliency and tendency of the tongues 11 to spring outwardly, the latching engagement between the openings 11a and detents 18a is rendered very 20 efficient.

From the foregoing detailed description, it is thought that the manner of use of the device will be quite apparent. A few words of explanation, however, might be helpful. The base mem- 25 ber 10 with its tongues may be of any preferred construction and size, and is usually adapted to be detachably engaged upon a fixture carried by a binder cover (not shown). In securing papers or correspondence upon this base member said 30 papers which are provided with spaced perforations are threaded over the tongues when the latter are extended in an upward direction, as shown at the right of Fig. 1 and in Fig. 3. After 35 the papers are mounted on the tongues the retaining member 14 is slipped between the tongues either by dropping it directly over the upstanding ends thereof or by first engaging one fork around one tongue and then the other fork about the 40 other tongue. The portions of the tongues projecting above the surface of the papers to be filed are then bent downwardly over the shoulder provided at the inner ends of the forks or notches into the channel 16, after which the locks 18 are 45 moved along the rails into latching engagement with the tongues. If it is desired to add additional papers to the binder or to remove any papers therefrom, this can be quickly accomplished by unlatching the locks from the tongues, bend- 50 ing the tongues to an upward position, whereupon the retaining member can be easily withdrawn. It will thus be seen that the speed and convenience with which the retaining member can be applied and removed is not impaired even though the

tongues are wrinkled or humped due to repeated bending in use.

Although I have shown and described a preferred embodiment of my invention, I do not wish to be limited to the precise details of construction, since the same might be varied without departing from the spirit of the invention as defined in the accompanying claims.

What I claim is:

1. A fastener comprising a base having spaced 10 tongues and a retaining member having rails at its longitudinal edges providing a fork at each end of the member of a width to receive the tongues and a longitudinal channel in the top of the member into which the tongues may be bent, 15 and locks bridging the channel carried by and slidable over said rails to hold the bent down tongues within the channel.

2. A retaining member for fasteners comprising an elongate relatively flat element having rails 20 at its longitudinal edges providing a fork at each end of the member and a longitudinal channel in the top of the member and locks bridging the channel carried by and movable over said rails.

3. A retaining member for fasteners comprising an elongate relatively flat element having rails at its longitudinal edges providing a fork 25 at each end of the member and a longitudinal channel in the top of the member, the rails at the forked ends of the member having portions thereof extending downwardly and terminating 30 in the plane of the bottom of the flat element.

4. A retaining member for fastener comprising an elongate relatively flat element having rails at its longitudinal edges providing a fork 35 at each end of the member and a longitudinal channel in the top of the member, the rails at the forked ends of the member having portions thereof extended outwardly to increase the width of the element at said parts and locks bridging the 40 channel carried by and movable over said rails and held against movement beyond the forked ends by the outwardly extending portions of the rails.

5. A retaining member for fasteners comprising an elongate relatively flat element having rails at its longitudinal edges providing a fork 45 at each end of the member and a longitudinal channel in the top of the member and locks bridging the channel carried by and movable over said rails, said locks having their edges engaging around the rails and being disposed above 50 the plane of the bottom of the flat element.

HERMAN FORTH.