

A. P. DURANT.

Gang-Plow.

No. 52,401.

Patented Feb. 6, 1866.

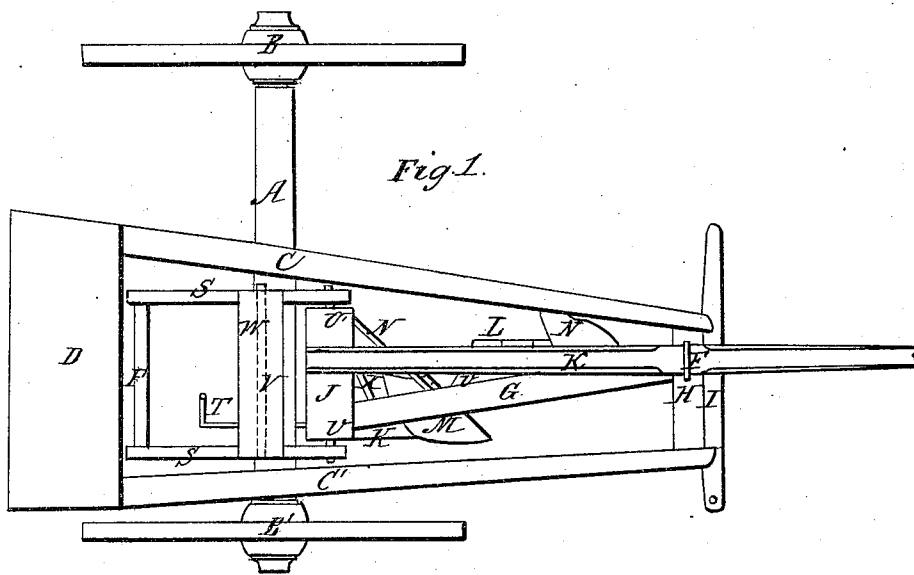

Fig. 1.

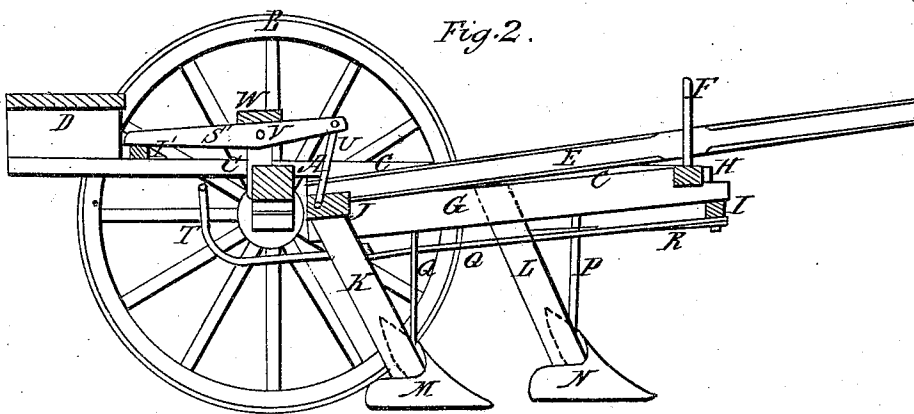

Fig. 2.

Witnesses.
C. Bartlett.
Peter A. Kenny.

Inventor.
A. P. Durant.
By Amos Bradford
Atty.

UNITED STATES PATENT OFFICE.

A. P. DURANT, OF ATLANTA, ILLINOIS.

IMPROVEMENT IN GANG-PLOWS.

Specification forming part of Letters Patent No. 52,401, dated February 6, 1866.

To all whom it may concern:

Be it known that I, A. P. DURANT, of Atlanta, Logan county, State of Illinois, have invented a new and Improved Gang-Plow; and I do hereby declare the following to be a full, clear, and exact description of the same, reference being had to the annexed drawings, making part of this specification, in which—

Figure 1 shows a top view of said plow, and Fig. 2 a longitudinal section on the line A' A'.

This invention relates to that class of gang-plows known as the "wheel and axle" variety; and it consists in a novel method of hanging and adjusting the plows in respect to the axle-tree and of operating and bracing the same.

To enable any one skilled in the art to which my invention appertains to make and use the same, I will proceed to describe the construction and operation thereof, reference being had to the drawings, in which similar letters of reference represent corresponding parts, and in which—

A represents the axle-tree; B B', the wheels; and C C', the frame, to which the various working parts are fixed, adjusted, and arranged.

The frame-pieces C C', it will be seen, reach well forward of the axle-tree, where their front ends are united by means of a pivot cross-tie, H, which is so arranged as to rock freely about its own axis, while at the same time it secures the end of the frame-pieces C C', as aforesaid. The rear ends of said frame-pieces are secured by a plank, D, and are made to reach far enough abaft the axle-tree to aid in balancing the plows and beams in front thereof when the driver is seated upon the plank D, which is designed for the seat of the operator.

The plow-beam is represented in the drawings by G, and the front end thereof is secured to the pivoted tie H, and is arranged diagonally in the frame C C', so that with the aid of a small set-off block, v, both plow-shanks K L can be secured to one beam, and yet be arranged upon distinct vertical planes far enough apart to allow each plow M N its proper furrow.

To the rear end of the plow-beam a truss-block, J, is fixed and trussed by braces X Y,

and to which the rear end of the tongue E is secured in the manner shown. In each end of this truss-block a pivot is fixed, to which two levers, S S', are connected by means of links U' U. These two levers have their fulcrums at V in a pair of uprights fixed on the axle-tree for that purpose; and said levers are united to each other so as to form a stiff truss-like frame by means of a plank, W, and a cross-tie, I'. By means of these levers the rear end of the plow-beam is raised and the plows lifted out of the ground, and by uniting these levers as I have described and connecting them to the ends of the truss-block J the plow-beam is kept from twisting and the plows from sluing or creeling from their proper path in the ground.

The double-tree I, to which the power is applied, is fixed to the under side of the front end of the plow-beam, and from the lower side of it a brace, R, is led back through the rear plow-shank, K, to the rear of which it rises up behind the axle and terminates in a foot-piece, T, upon which the operator may put his foot and press the plows in the ground.

Upon the tie H a clevis, F, is erected, through which the tongue passes, and in which it is adjusted up or down by means of adjustable pins to regulate the dip or draft of the plows.

Having now described the construction and operation of my invention, I claim and desire to secure by Letters Patent—

1. Uniting the two plows M N to a single beam, G, when said beam is arranged between the frame C C', and hung on a pivot to the front end thereof and forward of the axle-tree, substantially as shown and described.

2. The two levers S S', when united together in the manner described, and connected to the rear end of the plow-beam G, for the purpose of keeping said beam from twisting or the plows from sluing or creeling out of their proper path, and for the purpose of raising them out of the ground, as set forth.

A. P. DURANT.

Witnesses:

JACOB YAZEL,
OLIVER S. ALLEE.