



- (51) International Patent Classification:  
H04B 15/00 (2006.01)
- (21) International Application Number:  
PCT/US2015/018121
- (22) International Filing Date:  
27 February 2015 (27.02.2015)
- (25) Filing Language: English
- (26) Publication Language: English
- (30) Priority Data:  
61/945,507 27 February 2014 (27.02.2014) US
- (71) Applicant (for all designated States except US): **HUAWEI TECHNOLOGIES CO., LTD.** [CN/CN]; Huawei Administration Building, Bantian, Longgang District, Shenzhen, Guangdong 518129 (CN).
- (71) Applicant (for US only): **FUTUREWEI TECHNOLOGIES, INC.** [US/US]; 5340 Legacy Drive, Suite 175, Plano, Texas 75024 (US).
- (72) Inventors: **LE-NGOC, Tho**; 8221 du Mail, Montreal, Québec H1K 1Z5 (CA). **HUBERMAN, Sean**; 8 Jack Aaron Dr., Nepean, Ontario K2G 6L4 (CA).
- (74) Agent: **WIEBUSCH, Landon E.**; 17950 Preston Rd., Suite 1000, Dallas, Texas 75252 (US).

- (81) Designated States (unless otherwise indicated, for every kind of national protection available): AE, AG, AL, AM, AO, AT, AU, AZ, BA, BB, BG, BH, BN, BR, BW, BY, BZ, CA, CH, CL, CN, CO, CR, CU, CZ, DE, DK, DM, DO, DZ, EC, EE, EG, ES, FI, GB, GD, GE, GH, GM, GT, HN, HR, HU, ID, IL, IN, IR, IS, JP, KE, KG, KN, KP, KR, KZ, LA, LC, LK, LR, LS, LU, LY, MA, MD, ME, MG, MK, MN, MW, MX, MY, MZ, NA, NG, NI, NO, NZ, OM, PA, PE, PG, PH, PL, PT, QA, RO, RS, RU, RW, SA, SC, SD, SE, SG, SK, SL, SM, ST, SV, SY, TH, TJ, TM, TN, TR, TT, TZ, UA, UG, US, UZ, VC, VN, ZA, ZM, ZW.
- (84) Designated States (unless otherwise indicated, for every kind of regional protection available): ARIPO (BW, GH, GM, KE, LR, LS, MW, MZ, NA, RW, SD, SL, ST, SZ, TZ, UG, ZM, ZW), Eurasian (AM, AZ, BY, KG, KZ, RU, TJ, TM), European (AL, AT, BE, BG, CH, CY, CZ, DE, DK, EE, ES, FI, FR, GB, GR, HR, HU, IE, IS, IT, LT, LU, LV, MC, MK, MT, NL, NO, PL, PT, RO, RS, SE, SI, SK, SM, TR), OAPI (BF, BJ, CF, CG, CI, CM, GA, GN, GQ, GW, KM, ML, MR, NE, SN, TD, TG).

**Published:**

— with international search report (Art. 21(3))

(54) Title: SYSTEM AND METHOD FOR MULTIPLE-INPUT AND MULTIPLE-OUTPUT (MIMO) FULL-DUPLEX PRECODING STRUCTURES

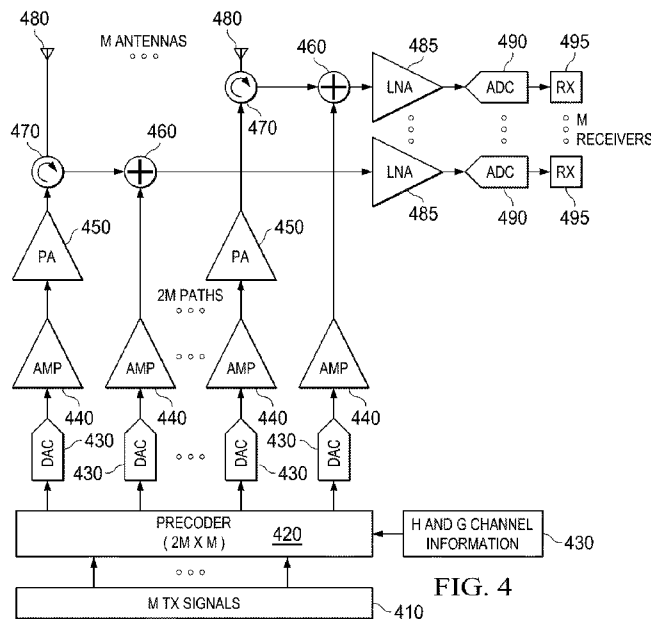

(57) Abstract: Embodiments are provided to enable effective cancellation or reduction of the self-interference (SI) introduced when applying full-duplex (FD) transmission to Multiple-Input-Multiple-Output (MIMO) systems. A method embodiment includes forming, using a precoding matrix generated in accordance with channel conditions, a plurality of beams for a plurality of transmit signals and a plurality of self-interference cancellation signals corresponding to the plurality of transmit signals. The method further includes transmitting, at a plurality of antennas, the plurality of beams for the transmit signals, and receiving, via the plurality of antennas, a plurality of receive signals. A corresponding self-interference cancellation signal is then added to each of the plurality of receive signals to obtain a plurality of corrected receive signals, and the plurality of corrected receive signals are detected at a plurality of receivers.

WO 2015/131116 A1

## **System and Method for Multiple-Input and Multiple-Output (MIMO) Full-Duplex Precoding Structures**

This application claims the benefit of U.S. Provisional Application No. 61/945,507 filed on February 27, 2014 by Tho Le-Ngoc et al. and entitled “Multiple-Input and Multiple-Output (MIMO) Full-Duplex Precoding Structure,” which is hereby incorporated herein by reference as if reproduced in its entirety.

### TECHNICAL FIELD

The present invention relates to wireless communications and networking, and, in particular embodiments, to a system and method for Multiple-Input and Multiple-Output (MIMO) Full-Duplex precoding.

### BACKGROUND

Half Duplex (HD) transmission systems transmit and receive signals in alternate time windows. An HD transceiver will either transmit or receive a signal in a particular frequency band over single defined time window Full-Duplex (FD) transmission systems can both transmit and receive signals in a given frequency band at the same time. FD systems have the potential to provide approximately double sum-rate improvements over HD systems. However, FD systems often suffer from high self-interference. Self-interference refers to the error added to the detected received signal that can be attributed to reflection and/or leakage of the transmitted signal into the receiver path in the system. Multiple-Input-Multiple-Output (MIMO) transmission systems, where multiple antennas are used at both the transmitter and receiver to improve communication performance, have also been developed. MIMO systems and techniques can provide increases in data throughput and link range without additional bandwidth or increased transmit power in comparison to a single antenna system. These improvements over single input single output systems can be achieved by spreading the same total transmit power over multiple antennas to achieve at least one of an array gain that improves the spectral efficiency (more bits per second per hertz of bandwidth) and/or a diversity gain that improves the link reliability. There is a need for effective self-interference mitigation to realize the benefits of FD operation in MIMO systems.

### SUMMARY OF THE INVENTION

In accordance with an embodiment, a method performed by a network component for full-duplex communications in a Multiple-Input and Multiple-Output (MIMO) system includes forming,

using a precoding matrix generated in accordance with channel conditions, a plurality of beams for a plurality of transmit signals and a plurality of self-interference cancellation signals corresponding to the plurality of transmit signals. The method further includes transmitting, at a plurality of antennas, the plurality of beams for the transmit signals, and receiving, via the plurality of antennas, a plurality of receive signals. A corresponding self-interference cancellation signal is then added to each of the plurality of receive signals to obtain a plurality of corrected receive signals, and the plurality of corrected receive signals are detected at a plurality of receivers.

In accordance with another embodiment, a method performed by a network component for full-duplex communications in a MIMO system includes forming, using a first precoding matrix generated in accordance with signal channel conditions, a plurality of beams corresponding to a plurality of transmit signals, and further forming, using a second precoding matrix generated in accordance with signal channel conditions, a plurality of self-interference cancellation signals corresponding to the plurality of transmit signals. The method further includes transmitting, at a plurality of antennas, the plurality of beams for the transmit signals, and receiving, via the plurality of antennas, a plurality of receive signals. A corresponding self-interference cancellation signal is then added to each of the plurality of receive signals to obtain a plurality of corrected receive signals, and the plurality of corrected receive signals are detected at a plurality of receivers.

In accordance with yet another embodiment, a network component for full-duplex communications in a MIMO comprises a processor and a non-transitory computer readable storage medium storing programming for execution by the processor. The programming includes instructions to form, using a precoding matrix generated in accordance with channel conditions, a plurality of beams for a plurality of transmit signals and a plurality of self-interference cancellation signals corresponding to the plurality of transmit signals. The network component further comprises a plurality of antennas configured to transmit the plurality of beams for the plurality of transmit signals and to receive a plurality of receive signals, and a plurality of combiners or couplers configured to add, to each of the plurality of receive signals, a corresponding self-interference cancellation signal to obtain a plurality of corrected receive signals. The network component also includes a plurality of receivers configured to detect the plurality of corrected receive signals.

The foregoing has outlined rather broadly the features of an embodiment of the present invention in order that the detailed description of the invention that follows may be better understood. Additional features and advantages of embodiments of the invention will be described hereinafter, which form the subject of the claims of the invention. It should be appreciated by those skilled in the

art that the conception and specific embodiments disclosed may be readily utilized as a basis for modifying or designing other structures or processes for carrying out the same purposes of the present invention. It should also be realized by those skilled in the art that such equivalent constructions do not depart from the spirit and scope of the invention as set forth in the appended claims.

## 5 BRIEF DESCRIPTION OF THE DRAWINGS

For a more complete understanding of the present invention, and the advantages thereof, reference is now made to the following descriptions taken in conjunction with the accompanying drawing, in which:

Figure 1 illustrates a full-duplex MIMO point-to-point network;

10 Figure 2 illustrates a full-duplex MIMO point-to-multipoint network with half-duplex user equipment;

Figure 3 illustrates a full-duplex MIMO point-to-multipoint network with full-duplex user equipment;

Figure 4 illustrates an embodiment of a MIMO full-duplex precoding structure;

15 Figure 5 illustrates an embodiment of a full-duplex operation method that can be used for MIMO systems; and

Figure 6 is a diagram of a processing system that can be used to implement various embodiments.

20 Corresponding numerals and symbols in the different figures generally refer to corresponding parts unless otherwise indicated. The figures are drawn to clearly illustrate the relevant aspects of the embodiments and are not necessarily drawn to scale.

## DETAILED DESCRIPTION OF ILLUSTRATIVE EMBODIMENTS

The making and using of the presently preferred embodiments are discussed in detail below. It should be appreciated, however, that the present invention provides many applicable inventive 25 concepts that can be embodied in a wide variety of specific contexts. The specific embodiments discussed are merely illustrative of specific ways to make and use the invention, and do not limit the scope of the invention.

In MIMO systems, algorithms are used to calculate a precoding channel matrix that determines the transmission of multiple channels to multiple users while avoiding (or substantially

reducing) signal interferences between the different receiving user equipments (UEs) or mobile stations (MSs). Conventional MIMO systems use HD transmissions. Applying FD transmission to MIMO systems can provide approximately double sum-rate improvements over standard HD MIMO systems. However, conventional FD transmission schemes typically suffer from high self-interference (SI). Embodiments are provided herein to enable effective cancellation (or reduction) of the SI introduced when applying FD transmission to the MIMO system. The embodiments include using a FD precoding structure and an effective full-duplex cancellation scheme that can be implemented in MIMO systems. A MIMO FD Precoding (FDP) structure is used to address both beam-forming for the forward or transmit channel and self-interference suppression. The methods discussed herein are applicable to a plurality of modulation formats including Orthogonal Frequency-Division Multiplexing (OFDM). Those skilled in the art will appreciate that for the sake of ease of presentation, the following discussion will focus on the application of the methods to OFDM transmissions. The precoding structure allows for various precoding algorithms and different optimization criteria/objectives to be developed for both point-to-point and point-to-multipoint MIMO FD systems. Specifically, the structure includes a combination of a beam-former and a self-interference canceller. Such structure provides additional transmit degrees of freedom.

Figures 1, 2, and 3 show embodiments of FD MIMO networks, where the precoding structure can be used. Figure 1 illustrates a FD MIMO point-to-point network. The FD single-user MIMO network includes a network entity 110, e.g., a base station, that serves a user equipment (UE) 120, e.g., a smartphone, a laptop, or any other suitable user operated device. Both the network entity 110 and the UE 120 can communicate using FD transmission (can transmit and receive at the same time) with multiple antennas according to the MIMO scheme and the FDP structure described further below. As can be seen from the figures, when transmitting in FD mode, the transmitted signal can be received by the receive antenna of the same device. This is a manifestation of the self-interference phenomenon that will be addressed below. Figure 2 illustrates a FD multi-user MIMO network with HD UE. This network includes a network entity 210 (e.g., a base station) that serves multiple UEs 220. In this scenario, the network entity 210 can communicate with each UE 220 using FD transmission, while each UE 220 communicates with the network entity 210 using HD transmission (e.g., the UE can either transmit or receive at any particular moment, while the network entity can transmit and receive simultaneously). Each one of the network entity 210 and UEs 220 use multiple antennas according to the MIMO scheme. Figure 3 illustrates a FD MIMO point-to-multipoint network with FD UEs. In this

scenario, the network entity 310 and the UEs 320 can communicate using FD transmission with multiple antennas.

Figure 4 illustrates an embodiment of a MIMO FD precoding structure. The precoding structure can be part of a FD transmitter/receiver (transceiver) 400 with  $M$  transmit/receive antennas, where  $M$  is an integer. For example, the transceiver can correspond to any of the network entities 110, 210 or 310 or to the UEs 120 or 320 with FD communications capability in the scenarios above. The  $M$  transmit (Tx) signals from transmitter 410 are preprocessed by a precoder 420 using a  $2M \times M$  precoding matrix. Using the precoding matrix, the precoder 420 acts as a joint beam-former for forward transmission and self-interference canceller, for instance with the objective of maximizing the sum-rate. The  $M$  Tx signals are split into  $2M$  paths, as shown in Figure 4. Each of the  $2M$  paths includes a Digital-to-Analog Converter (DAC) 430 and an amplifier (Amp) 440.

The  $2M$  paths include a subset of  $M$  paths from the precoder 420, referred to herein as  $M$  Tx paths, which is used for forward transmission. Each of the  $M$  Tx paths also include a Power Amplifier (PA) 450, and a circulator 470. A circulator is a passive device in which a signal enters one port and is transmitted to the next port by rotation. The circulator 470 allows for the transceiver 400 to transmit and receive simultaneously while providing some passive isolation between the  $M$  Tx paths from the precoder 420 and the  $M$  receive paths to the  $M$  receivers (Rx) 495. However, the transceiver 400 can require significantly more cancellation than the circulator 470 provides in order to have reliable signal detection. In another embodiment, an isolator can be used instead of the circulator 470. The isolator is another passive device that allows for the transceiver 400 to transmit and receive simultaneously while providing isolation between the  $M$  Tx paths from the precoder 420 and the  $M$  receive paths to the  $M$  receivers (Rx) 495.

The  $2M$  paths also include a second subset of  $M$  paths to the combiners 460, referred to herein as  $M$  SI cancellation paths, form an equivalent to an active canceller to cancel the self-interference. However, the objective of the precoding is not necessarily to focus on minimizing the self-interference. The  $M$  SI cancellation paths are connected to their respective  $M$  receive paths via combiners 460. The combiners are any suitable devices capable of combining signals together, and are also referred to herein as couplers. Each combiner or coupler 460 is positioned between a circulator 470 on the corresponding antenna 480 side and a low noise amplifier (LNA) 485 and an analog to digital converter (ADC) 490 on the corresponding receiver 495 side. In each of the  $M$  receive paths, the combiner 460 adds an SI signal carried by an SI cancellation path. This effectively mitigates SI in the receivers 495. The SI cancellation signals are calculated using the  $2M \times M$  precoder

420 with the  $M$  Tx paths as part of a joint beam-forming and SI cancellation precoding. The precoding is established using channel information 430 (e.g., H and G channel matrices). The channel information 430 can be obtained via channel measurements, e.g., during a preliminary HD transmission phase.

5           The precoding structure of the transceiver 400, as shown in Figure 4, makes use of MIMO precoding to jointly beam-form the forward transmission and cancel the self-interference. As such, the cancellation is done by matrix precoding. Additionally, this structure allows for different optimization objectives (rather than solely minimizing self-interference). For instance, the transmit signals can be preprocessed using matrix precoding (using the  $2M \times M$  precoding matrix at the  
10       precoder 420) to maximize the sum-rate and achieve a trade-off between the forward channel beam-forming and the self-interference suppression. Hence, the precoding structure provides a more generalized framework for the optimization of both single-user and multi-user full-duplex transceivers.

          In another embodiment, two separate precoding matrices can be used for the  $M$  Tx paths  
15       (forward or transmit channels) and the  $M$  SI cancellation paths (self-interference channels). In this case, one  $M \times M$  precoder is applied to the forward channel and another  $M \times M$  precoder is applied to the self-interference channels. This approach to separate the  $2M \times M$  precoding matrix into two  $M \times M$  precoder matrices corresponds to a matrix-version of an active cancellation approach, where the cancellations are computed via precoding.

20           Other embodiments include transceivers with dedicated transmit and receive antennas. Such embodiments would not require the use of circulators but would require additional antenna arrangements. In another embodiment, the transceivers have different numbers of transmit and receive antennas. In yet another embodiment, the precoding scheme above is combined with existing passive cancellation techniques. In various embodiments, various methods can be used for obtaining  
25       channel information, including off-line and online measurements and/or estimation techniques.

          Other embodiments include joint precoding matrices of different dimensions than  $2M \times M$ . For example, the  $M$  transmit signals could be expanded to  $2M$  transmit signals by padding the original  $M$  transmit signals with  $M$  zeros, leading to a  $2M \times 2M$  square precoding matrix which may have some advantages from a mathematical optimization or computation perspective.

30           One feature of the disclosure is providing a generalized framework for optimization of both single-user and multi-user FD transceivers. The disclosure also allows for different optimization

objectives other than minimizing self-interference (e.g., maximizing sum-rate), and allows for joint beam-former and self-interference canceller. Another advantage is simplifying implementation for MIMO structures.

In an embodiment, the precoding structure of Figure 4 above can be applied at the base station to operate in FD mode and increase the capacity (bits/second/Hertz/area). This is also applicable for small-cell deployments supporting an LTE or next generation networks such as a 5<sup>th</sup> generation (5G) network, for example. The structure can also be applied at a wireless device (e.g., WiFi) or other non-RAN technology and benefits both the user and the service provider by providing significant capacity increases. FD systems are a strong candidate for increasing the capacity of wireless networks. The embodiments herein provide a practical structure for both point-to-point and point-to-multipoint FD systems. Further details of the precoding structure and the joint use of the beam-former and SI canceller are described by Sean Huberman and Tho Le-Ngoc in a technical paper draft entitled “MIMO Full-Duplex Precoding: A Joint Beamforming and Self-Interference Cancellation Structure”.

Figure 5 illustrates an embodiment of a full-duplex operation method that can be used for MIMO systems. The method can be implemented using the precoding structure above. At step 510,  $M$  Tx signals corresponding to  $M$  MIMO antennas are obtained at a precoder in a transceiver. At step 520, a  $2M \times M$  precoding matrix is established at the precoder. Specifically, the  $2M \times M$  precoding matrix is established according to channel information to form the forward or transmit beams for  $M$  Tx signals from the precoder to  $M$  antennas in accordance with MIMO transmission. Additionally, the  $2M \times M$  precoding matrix is established to form  $M$  SI cancellation signals from the precoder and achieve self-interference cancellation in the  $M$  receive paths to the  $M$  receivers. At step 530, the  $M$  SI cancellation signals are added, via combiners (or couplers), to the  $M$  receive paths between the receivers and corresponding circulators (or isolators) on the Tx paths. The combination of the  $M$  SI cancellation signals with the respective  $M$  received signals to the  $M$  receivers effectively cancels or substantially reduces the SI signal (or SI error) in the  $M$  received and hence detected signals by the receivers. At step 540, after adding the  $M$  SI cancellation signals to the  $M$  receive paths, the resulting signals are detected by the  $M$  receivers (or detectors).

Figure 6 is a block diagram of a processing system 600 that can be used to implement various embodiments. For instance the processing system 600 can be part of a UE, such as a smart phone, tablet computer, a laptop, or a desktop computer. The system can also be part of a network entity or

component that serves the UE, such as a base station or a WiFi access point. The processing system can also be part of a network component, such as a base station. Specific devices may utilize all of the components shown, or only a subset of the components, and levels of integration may vary from device to device. Furthermore, a device may contain multiple instances of a component, such as

5 multiple processing units, processors, memories, transmitters, receivers, etc. The processing system 600 may comprise a processing unit 601 equipped with one or more input/output devices, such as a speaker, microphone, mouse, touchscreen, keypad, keyboard, printer, display, and the like. The processing unit 601 may include a central processing unit (CPU) 610, a memory 620, a mass storage device 630, a video adapter 640, and an I/O interface 660 connected to a bus. The bus may be one or

10 more of any type of several bus architectures including a memory bus or memory controller, a peripheral bus, a video bus, or the like.

The CPU 610 may comprise any type of electronic data processor. In an embodiment, the processor may serve as a precoder for generating the  $2M \times M$  precoding matrix, such as the precoder 420. The memory 620 may comprise any type of system memory such as static random access

15 memory (SRAM), dynamic random access memory (DRAM), synchronous DRAM (SDRAM), read-only memory (ROM), a combination thereof, or the like. In an embodiment, the memory 620 may include ROM for use at boot-up, and DRAM for program and data storage for use while executing programs. In embodiments, the memory 620 is non-transitory. The mass storage device 630 may comprise any type of storage device configured to store data, programs, and other information and to

20 make the data, programs, and other information accessible via the bus. The mass storage device 630 may comprise, for example, one or more of a solid state drive, hard disk drive, a magnetic disk drive, an optical disk drive, or the like.

The video adapter 640 and the I/O interface 660 provide interfaces to couple external input and output devices to the processing unit. As illustrated, examples of input and output devices

25 include a display 690 coupled to the video adapter 640 and any combination of mouse/keyboard/printer 670 coupled to the I/O interface 660. Other devices may be coupled to the processing unit 601, and additional or fewer interface cards may be utilized. For example, a serial interface card (not shown) may be used to provide a serial interface for a printer.

The processing unit 601 also includes one or more network interfaces 650, which may

30 comprise wired links, such as an Ethernet cable or the like, and/or wireless links to access nodes or one or more networks 680. The network interface 650 allows the processing unit 601 to communicate with remote units via the networks 680. For example, the network interface 650 may provide

wireless communication via one or more transmitters/transmit antennas and one or more receivers/receive antennas. In an embodiment, the processing unit 601 is coupled to a local-area network or a wide-area network for data processing and communications with remote devices, such as other processing units, the Internet, remote storage facilities, or the like.

5           While several embodiments have been provided in the present disclosure, it should be understood that the disclosed systems and methods might be embodied in many other specific forms without departing from the spirit or scope of the present disclosure. The presented examples are to be considered as illustrative and not restrictive, and the intention is not to be limited to the details given herein. For example, the various elements or components may be combined or integrated in another  
10 system or certain features may be omitted, or not implemented.

In addition, techniques, systems, subsystems, and methods described and illustrated in the various embodiments as discrete or separate may be combined or integrated with other systems, modules, techniques, or methods without departing from the scope of the present disclosure. Other items shown or discussed as coupled or directly coupled or communicating with each other may be  
15 indirectly coupled or communicating through some interface, device, or intermediate component whether electrically, mechanically, or otherwise. Other examples of changes, substitutions, and alterations are ascertainable by one skilled in the art and could be made without departing from the spirit and scope disclosed herein.

## WHAT IS CLAIMED IS:

1. A method performed by a network component for full-duplex communications in a Multiple-Input and Multiple-Output (MIMO) system, the method comprising:
  - forming, using a precoding matrix generated in accordance with channel conditions, a
  - 5 plurality of beams for a plurality of transmit signals and a plurality of self-interference cancellation signals corresponding to the plurality of transmit signals;
  - transmitting, at a plurality of antennas, the plurality of beams for the transmit signals;
  - receiving, via the plurality of antennas, a plurality of receive signals;
  - adding, to each of the plurality of receive signals, a corresponding self-interference
  - 10 cancellation signal to obtain a plurality of corrected receive signals; and
  - detecting, at a plurality of receivers, the plurality of corrected receive signals.
2. The method of claim 1, wherein the forming step includes generating the precoding matrix for the transmit signals to satisfy an objective of maximizing a sum-rate of transmission and achieving a trade-off between forward channel beam-forming and self-interference suppression.
- 15 3. The method of claim 1, wherein the self-interference cancellation signals comprise a same quantity of signals as the beams for the transmit signals, and wherein each one of the self-interference cancellation signals corresponds to one of the beams for the transmit signals.
4. The method of claim 3, wherein the precoding matrix has a size of  $2M \times M$  where  $M$  is the quantity of the transmit signals.
- 20 5. The method of claim 3, wherein the receive signals comprise a same quantity of signals as the self-interference cancellation signals, and wherein each one of the self-interference signals corresponds to one of the receive signals.
6. The method of claim 1, wherein the precoding matrix is formed at a precoder, and wherein the step of receiving the plurality of receive signals includes receiving the plurality of receive signals
- 25 from the plurality of antennas through a plurality of circulators or isolators positioned on a plurality of transmit paths between the precoder and the antennas.

7. The method of claim 6, wherein the self-interference cancellation signals are added to the receive signals at the plurality of combiners on a plurality of receive paths between the circulators or isolators and the receivers.
8. The method of claim 1, wherein transmitting the beams for the transmit signals is done substantially simultaneously with receiving the receive signals.
9. The method of claim 1, wherein the network component is one of a wireless base station, a WiFi access point, and a user equipment.
10. A method performed by a network component for full-duplex communications in a Multiple-Input and Multiple-Output (MIMO) system, the method comprising:
- 10 forming, using a first precoding matrix generated in accordance with signal channel conditions, a plurality of beams corresponding to a plurality of transmit signals;
- forming, using a second precoding matrix generated in accordance with signal channel conditions, a plurality of self-interference cancellation signals corresponding to the plurality of transmit signals;
- 15 transmitting, at a plurality of antennas, the plurality of beams for the transmit signals;
- receiving, via the plurality of antennas, a plurality of receive signals;
- adding, to each of the plurality of receive signals, a corresponding self-interference cancellation signal to obtain a plurality of corrected receive signals; and
- detecting, at a plurality of receivers, the plurality of corrected receive signals.
- 20 11. The method of claim 10, wherein the self-interference cancellation signals comprise a same quantity of signals as the beams for the transmit signals, and wherein each one of the self-interference cancellation signals corresponds to one of the beams for the transmit signals.
12. The method of claim 11, wherein each one of the first precoding matrix and the second precoding matrix has a size of  $M \times M$  where  $M$  is the quantity of the transmit signals.
- 25 13. A network component for full-duplex communications in a Multiple-Input and Multiple-Output (MIMO) system, the network component comprising:
- a processor;

a non-transitory computer readable storage medium storing programming for execution by the processor, the programming including instructions to form, using a precoding matrix generated in accordance with channel conditions, a plurality of beams for a plurality of transmit signals and a plurality of self-interference cancellation signals corresponding to the plurality of transmit signals;

5 a plurality of antennas configured to transmit the plurality of beams for the plurality of transmit signals and to receive a plurality of receive signals;

a plurality of combiners or couplers configured to add, to each of the plurality of receive signals, a corresponding self-interference cancellation signal to obtain a plurality of corrected receive signals; and

10 a plurality of receivers configured to detect the plurality of corrected receive signals.

14. The network component of claim 13 further comprising a plurality of circulators or isolators positioned on a plurality of transmit paths between the processor and the plurality of antennas.

15. The network component of claim 14, wherein the plurality of transmit paths include a plurality of digital to analog converters (DACs) and a plurality of amplifiers positioned between the  
15 circulators or isolators and the processor.

16. The network component of claim 14, wherein the combiners or couplers are positioned on a plurality of receive paths between the circulators or isolators and the plurality of receivers.

17. The network component of claim 16, wherein the plurality of receive paths include a plurality of low noise amplifiers (LNAs) and a plurality of analog to digital converters (ADCs) positioned  
20 between the combiners or couplers and the receivers.

18. The network component of claim 16 further comprising a plurality of auxiliary paths between the processor and the plurality of combiners or couplers.

19. The network component of claim 18, wherein the plurality of auxiliary paths include a plurality of digital to analog converters (DACs) and a plurality of amplifiers positioned between the  
25 processor and the combiners or couplers.

20. The network component of claim 19, wherein a total number of the auxiliary paths is equal to a total number of the transmit paths and to a total number of the antennas.

21. The network component of claim 20, wherein a total number of the receive paths is equal to the total number of the transmit paths and to the total number of the antennas.

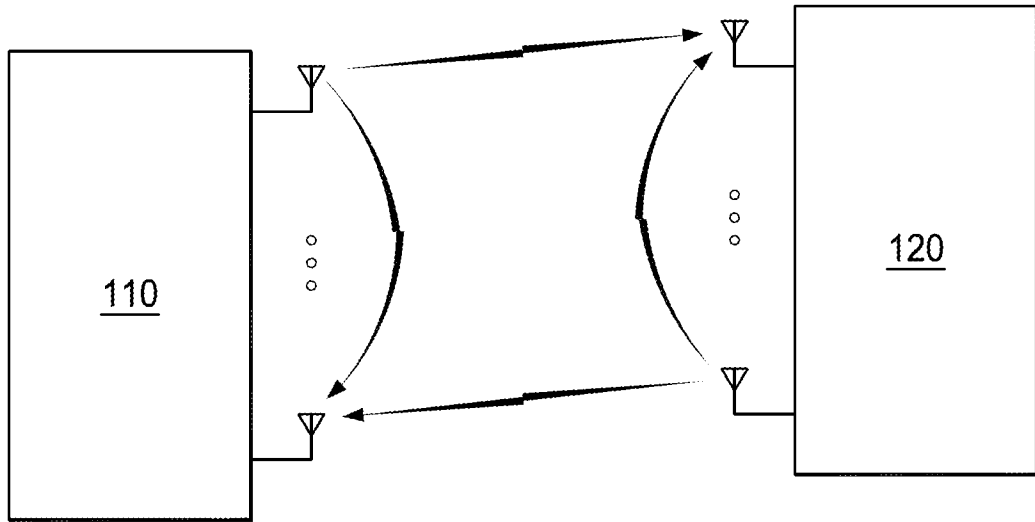

FIG. 1

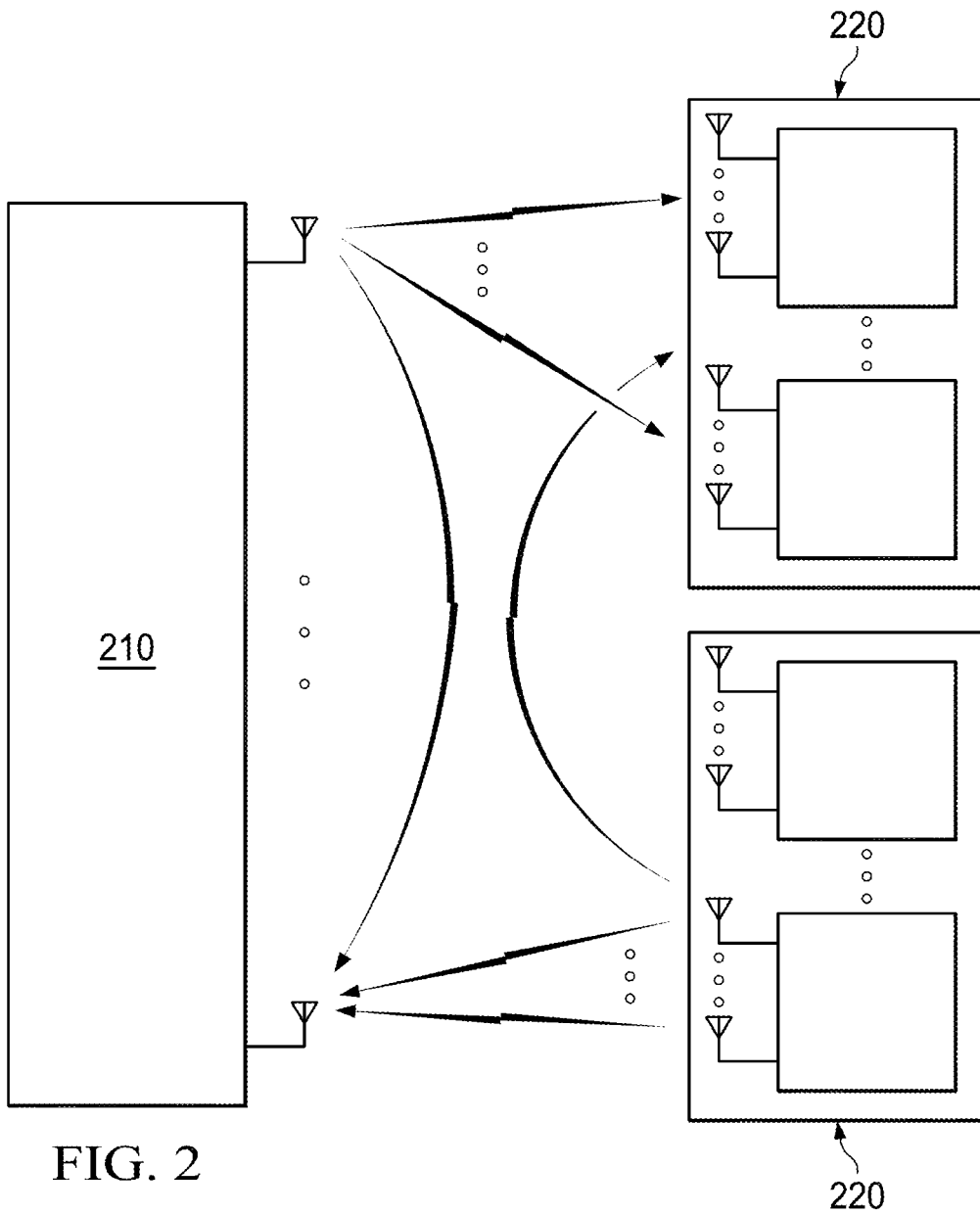

FIG. 2

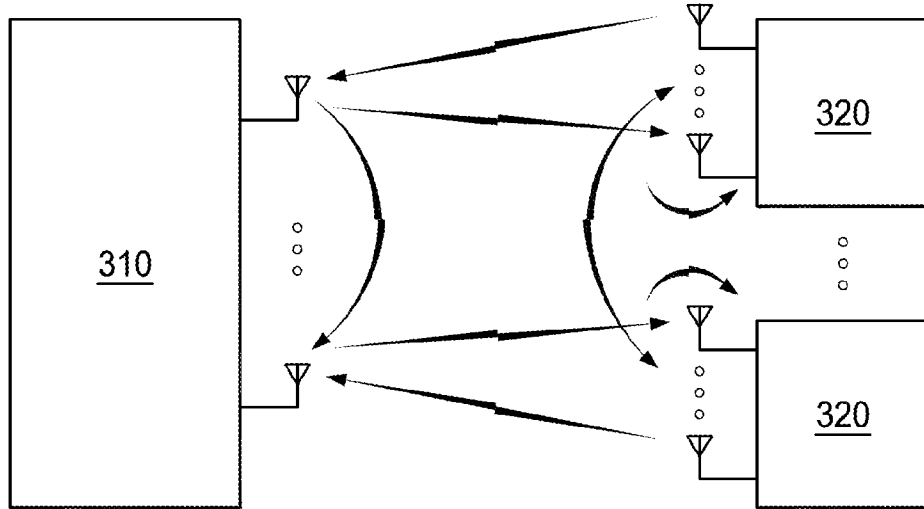

FIG. 3

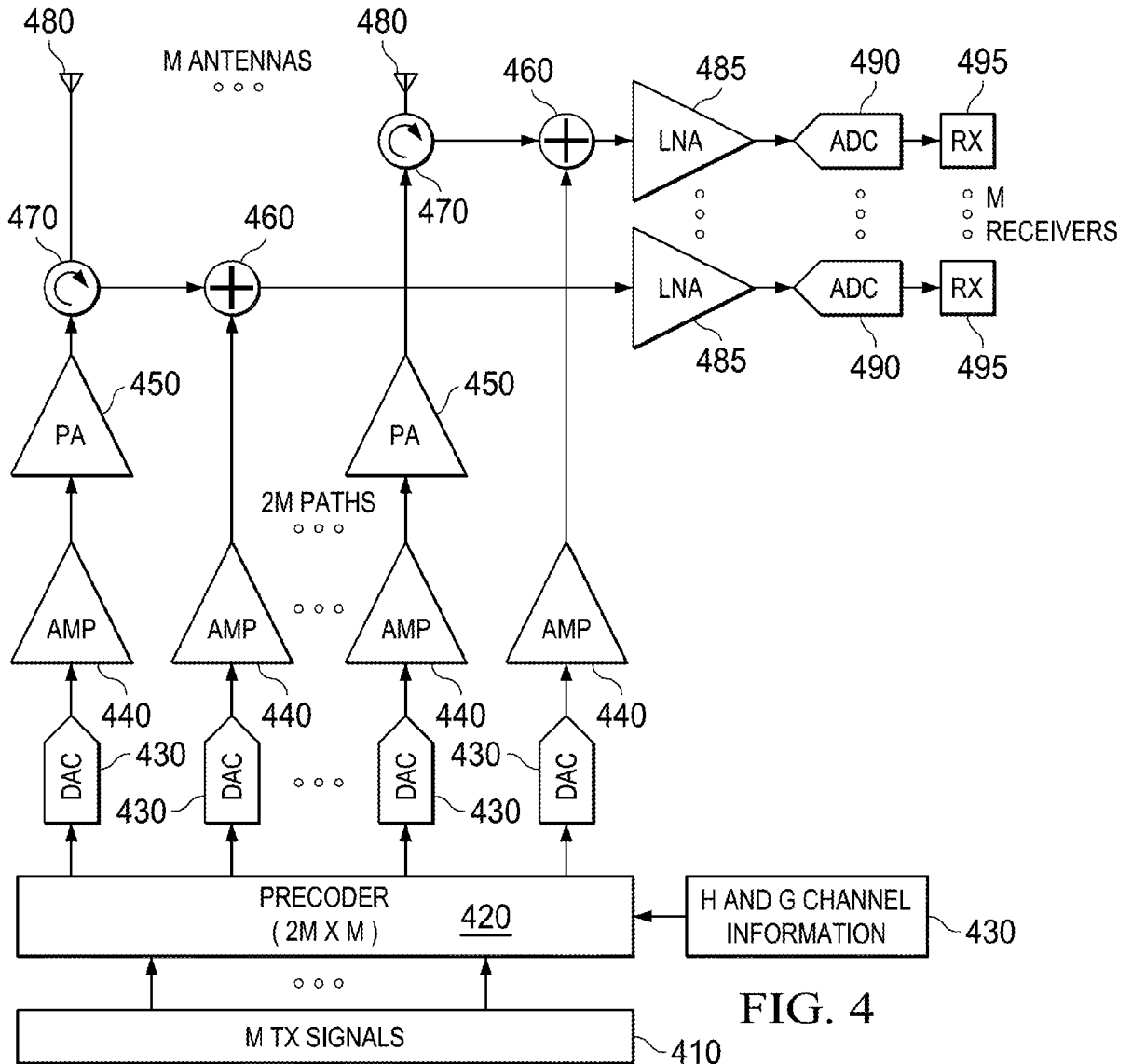

FIG. 4

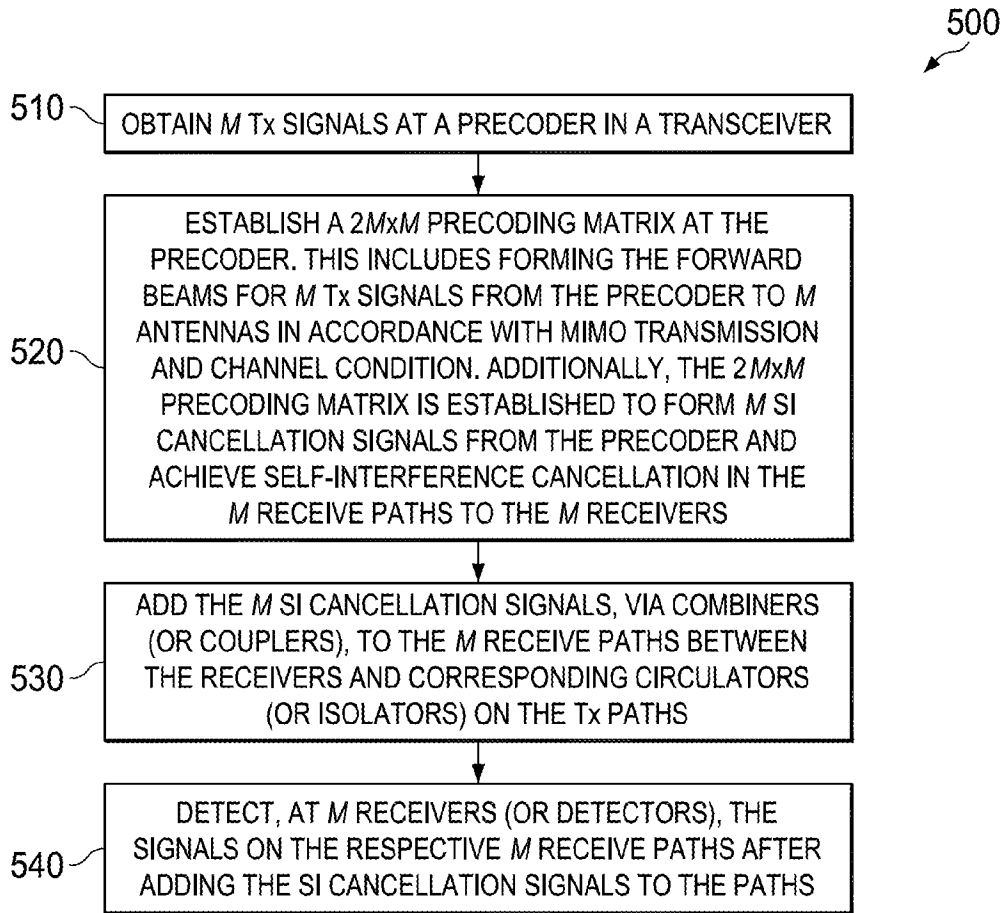

FIG. 5

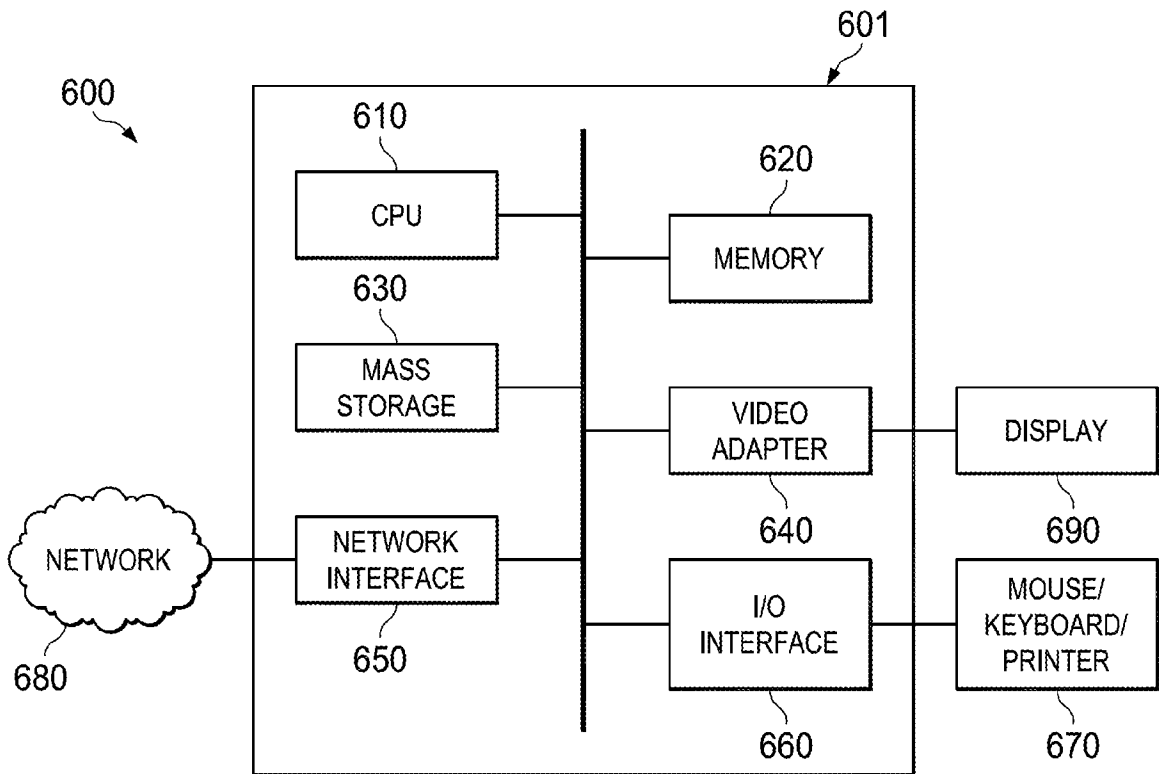

FIG. 6

**INTERNATIONAL SEARCH REPORT**

International application No.  
PCT/US2015/018121

<p><b>A. CLASSIFICATION OF SUBJECT MATTER</b>                  IPC(8) - H04B 15/00 (2015.01)                  CPC - H04B 15/00 (2015.04)                  According to International Patent Classification (IPC) or to both national classification and IPC</p>																										
<p><b>B. FIELDS SEARCHED</b></p> <p>Minimum documentation searched (classification system followed by classification symbols)                  IPC(8) - H04B 1/10, H04B 7/02, H04B 7/04, H04B 10/516, H04B 15/00 (2015.04)                  USPC - 370/276, 277, 278; 455/562.1, 575.7</p> <p>Documentation searched other than minimum documentation to the extent that such documents are included in the fields searched                  CPC - H04B 1/10, H04B 7/024, H04B 7/0413, H04B 7/0452, H04B 7/0456, H04B 10/5055, H04B 15/00 (2015.01) (keyword delimited)</p> <p>Electronic data base consulted during the international search (name of data base and, where practicable, search terms used)                  Orbit, Google Patents, Google.                  Search terms used: full-duplex, multiple-input multiple-output, mimo, precoding matrix, antennas, precoder, self-interference cancellation</p>																										
<p><b>C. DOCUMENTS CONSIDERED TO BE RELEVANT</b></p> <table border="1"> <thead> <tr> <th>Category*</th> <th>Citation of document, with indication, where appropriate, of the relevant passages</th> <th>Relevant to claim No.</th> </tr> </thead> <tbody> <tr> <td>X</td> <td>US 2013/0114468 A1 (HUI et al) 09 May 2013 (09.05.2013) entire document</td> <td>1-3, 5-6 and 8-13</td> </tr> <tr> <td>--</td> <td></td> <td>----</td> </tr> <tr> <td>Y</td> <td></td> <td>4, 7 and 14-21</td> </tr> <tr> <td>Y</td> <td>US 2004/0252632 A1 (BOURDOUX et al) 16 December 2004 (16.12.2004) entire document</td> <td>4</td> </tr> <tr> <td>Y</td> <td>WO 2013/120087 A1 (HUA et al) 15 August 2013 (15.08.2013) entire document</td> <td>7, 14-21</td> </tr> <tr> <td>A</td> <td>US 2013/0089009 A1 (LI et al) 11 April 2013 (11.04.2013) entire document</td> <td>1-21</td> </tr> <tr> <td>A</td> <td>EP 2 472 727 A1 (OLSSON et al) 04 July 2012 (04.07.2012) entire document</td> <td>1-21</td> </tr> </tbody> </table>			Category*	Citation of document, with indication, where appropriate, of the relevant passages	Relevant to claim No.	X	US 2013/0114468 A1 (HUI et al) 09 May 2013 (09.05.2013) entire document	1-3, 5-6 and 8-13	--		----	Y		4, 7 and 14-21	Y	US 2004/0252632 A1 (BOURDOUX et al) 16 December 2004 (16.12.2004) entire document	4	Y	WO 2013/120087 A1 (HUA et al) 15 August 2013 (15.08.2013) entire document	7, 14-21	A	US 2013/0089009 A1 (LI et al) 11 April 2013 (11.04.2013) entire document	1-21	A	EP 2 472 727 A1 (OLSSON et al) 04 July 2012 (04.07.2012) entire document	1-21
Category*	Citation of document, with indication, where appropriate, of the relevant passages	Relevant to claim No.																								
X	US 2013/0114468 A1 (HUI et al) 09 May 2013 (09.05.2013) entire document	1-3, 5-6 and 8-13																								
--		----																								
Y		4, 7 and 14-21																								
Y	US 2004/0252632 A1 (BOURDOUX et al) 16 December 2004 (16.12.2004) entire document	4																								
Y	WO 2013/120087 A1 (HUA et al) 15 August 2013 (15.08.2013) entire document	7, 14-21																								
A	US 2013/0089009 A1 (LI et al) 11 April 2013 (11.04.2013) entire document	1-21																								
A	EP 2 472 727 A1 (OLSSON et al) 04 July 2012 (04.07.2012) entire document	1-21																								
<p><input type="checkbox"/> Further documents are listed in the continuation of Box C. <input type="checkbox"/></p>																										
<p>* Special categories of cited documents:</p> <table border="0"> <tr> <td style="vertical-align: top;"> <p>"A" document defining the general state of the art which is not considered to be of particular relevance</p> <p>"E" earlier application or patent but published on or after the international filing date</p> <p>"L" document which may throw doubts on priority claim(s) or which is cited to establish the publication date of another citation or other special reason (as specified)</p> <p>"O" document referring to an oral disclosure, use, exhibition or other means</p> <p>"P" document published prior to the international filing date but later than the priority date claimed</p> </td> <td style="vertical-align: top;"> <p>"T" later document published after the international filing date or priority date and not in conflict with the application but cited to understand the principle or theory underlying the invention</p> <p>"X" document of particular relevance; the claimed invention cannot be considered novel or cannot be considered to involve an inventive step when the document is taken alone</p> <p>"Y" document of particular relevance; the claimed invention cannot be considered to involve an inventive step when the document is combined with one or more other such documents, such combination being obvious to a person skilled in the art</p> <p>"&amp;" document member of the same patent family</p> </td> </tr> </table>			<p>"A" document defining the general state of the art which is not considered to be of particular relevance</p> <p>"E" earlier application or patent but published on or after the international filing date</p> <p>"L" document which may throw doubts on priority claim(s) or which is cited to establish the publication date of another citation or other special reason (as specified)</p> <p>"O" document referring to an oral disclosure, use, exhibition or other means</p> <p>"P" document published prior to the international filing date but later than the priority date claimed</p>	<p>"T" later document published after the international filing date or priority date and not in conflict with the application but cited to understand the principle or theory underlying the invention</p> <p>"X" document of particular relevance; the claimed invention cannot be considered novel or cannot be considered to involve an inventive step when the document is taken alone</p> <p>"Y" document of particular relevance; the claimed invention cannot be considered to involve an inventive step when the document is combined with one or more other such documents, such combination being obvious to a person skilled in the art</p> <p>"&amp;" document member of the same patent family</p>																						
<p>"A" document defining the general state of the art which is not considered to be of particular relevance</p> <p>"E" earlier application or patent but published on or after the international filing date</p> <p>"L" document which may throw doubts on priority claim(s) or which is cited to establish the publication date of another citation or other special reason (as specified)</p> <p>"O" document referring to an oral disclosure, use, exhibition or other means</p> <p>"P" document published prior to the international filing date but later than the priority date claimed</p>	<p>"T" later document published after the international filing date or priority date and not in conflict with the application but cited to understand the principle or theory underlying the invention</p> <p>"X" document of particular relevance; the claimed invention cannot be considered novel or cannot be considered to involve an inventive step when the document is taken alone</p> <p>"Y" document of particular relevance; the claimed invention cannot be considered to involve an inventive step when the document is combined with one or more other such documents, such combination being obvious to a person skilled in the art</p> <p>"&amp;" document member of the same patent family</p>																									
<p>Date of the actual completion of the international search</p> <p>27 April 2015</p>		<p>Date of mailing of the international search report</p> <p><b>03 JUN 2015</b></p>																								
<p>Name and mailing address of the ISA/US</p> <p>Mail Stop PCT, Attn: ISA/US, Commissioner for Patents                  P.O. Box 1450, Alexandria, Virginia 22313-1450                  Facsimile No. 571-273-8300</p>		<p>Authorized officer:</p> <p>Blaine R. Copenheaver</p> <p>PCT Helpdesk: 571-272-4300                  PCT OSP: 571-272-7774</p>																								