

PCT

WORLD INTELLECTUAL PROPERTY ORGANIZATION  
International Bureau

EP0245285

INTERNATIONAL APPLICATION PUBLISHED UNDER THE PATENT COOPERATION TREATY (PCT)

(51) International Patent Classification <sup>4</sup> : A61K 49/00	A1	(11) International Publication Number: WO 88/ 00060 (43) International Publication Date: 14 January 1988 (14.01.88)
(21) International Application Number: PCT/US87/01588 (22) International Filing Date: 1 July 1987 (01.07.87) (31) Priority Application Numbers: 882,044 067,586 (32) Priority Dates: 3 July 1986 (03.07.86) 26 June 1987 (26.06.87) (33) Priority Country: US (71) Applicant: ADVANCED MAGNETICS INCORPORATED [US/US]; 45 Spinelli Place, Cambridge, MA 02138 (US). (72) Inventors: GROMAN, Ernest, V. ; 80 Columbia Street, Brookline, MA 02146 (US). JOSEPHSON, Lee ; 14 Churchhill Avenue, Arlington, MA 02174 (US). LEWIS, Jerome, M. ; 273 Upland Avenue, Newton, MA 02161 (US).	(74) Agent: MISROCK, S., Leslie; Pennie & Edmonds, 1155 Avenue of the Americas, New York, NY 10036 (US). (81) Designated States: AT (European patent), BE (European patent), CH (European patent), DE (European patent), FR (European patent), GB (European patent), IT (European patent), JP, LU (European patent), NL (European patent), NO, SE (European patent). Published With international search report.	

(54) Title: BIODEGRADABLE SUPERPARAMAGNETIC MATERIALS USED IN CLINICAL APPLICATIONS

## (57) Abstract

The *in vivo* use of biologically degradable and metabolizable superparamagnetic metal oxides as MR contrast agents. Depending on their preparation, these metal oxides are in the form of superparamagnetic particle dispersoids or superparamagnetic fluids where the suspending medium is a physiologically-acceptable carrier, and may be uncoated or surrounded by a polymeric coating to which biological molecules can be attached. In the case of coated particles, the biological molecules can be chosen to target specific organs or tissues. The biodistribution of the metal oxides in target organs or tissues results in a more detailed image of such organs or tissues because the metal oxides, due to their superparamagnetic properties, exert profound effects on the hydrogen nuclei responsible for the MR image.

*FOR THE PURPOSES OF INFORMATION ONLY*

Codes used to identify States party to the PCT on the front pages of pamphlets publishing international applications under the PCT.

AT	Austria	FR	France	ML	Mali
AU	Australia	GA	Gabon	MR	Mauritania
BB	Barbados	GB	United Kingdom	MW	Malawi
BE	Belgium	HU	Hungary	NL	Netherlands
BG	Bulgaria	IT	Italy	NO	Norway
BJ	Benin	JP	Japan	RO	Romania
BR	Brazil	KP	Democratic People's Republic of Korea	SD	Sudan
CF	Central African Republic	KR	Republic of Korea	SE	Sweden
CG	Congo	LI	Liechtenstein	SN	Senegal
CH	Switzerland	LK	Sri Lanka	SU	Soviet Union
CM	Cameroon	LU	Luxembourg	TD	Chad
DE	Germany, Federal Republic of	MC	Monaco	TG	Togo
DK	Denmark	MG	Madagascar	US	United States of America
FI	Finland				

1  
Biodegradable  
Superparamagnetic Materials Used In Clinical  
Applications

5 This application is a continuation-in-part of the  
applicants' prior co-pending U.S. Application Serial No.  
882,044 filed July 3, 1986, which is incorporated herein by  
reference.

1. INTRODUCTION

10

This invention relates to materials exhibiting certain magnetic and biological properties which make them uniquely suitable for use as magnetic resonance imaging (MRI) agents to enhance MR images of animal organs and tissues.

15 More particularly, the invention relates to the in vivo use of biologically degradable and metabolizable superparamagnetic metal oxides as MR contrast agents. Depending on their preparation, these metal oxides are in the form of superparamagnetic particle dispersoids or superparamagnetic

20 fluids where the suspending medium is a physiologically-acceptable carrier. These dispersoids and fluids are administered to animals, including humans, by a variety of routes and the metal oxides therein collect in specific target organs to be imaged. The biodistribution of the metal oxides

25 in target organs or tissues results in a more detailed image of such organs or tissues because the metal oxides, due to their superparamagnetic properties, exert profound effects on the hydrogen nuclei responsible for the MR image. In addition, the dispersoids and fluids are quite stable and, in

30 the case of the fluids, can even be subjected to autoclaving without impairing their utility. Thus, the materials are well-suited for in vivo use.

35

The combination of superparamagnetism and biodegradability makes the materials described herein particularly advantageous for use as MR contrast agents. Superparamagnetism, which results in profound capabilities to alter MR images, makes it possible to use these materials in concentrations lower than those required for MRI with other types of magnetic materials. Biodegradability results in optimum retention times within the organs and tissues to be imaged, i.e., the materials remain within the organ or tissue sufficiently long to permit an image to be obtained, yet are eventually cleared from or metabolized within the organ or tissue. Remarkably, when iron-based agents are administered, the iron thereon is eventually metabolized and incorporated into the subject's hemoglobin.

15

These materials can, therefore, be used for a variety of clinical diagnostic purposes including, but not limited to, detection of cancerous lesions in liver and other reticuloendothelial tissue, detection of cancerous or other lesions in the intestine, detection of liver diseases, such as cirrhosis and hepatitis, and assessment of liver regeneration. Those that are iron-based are also clinically useful as anti-anemia agents.

25

## 2. BACKGROUND OF THE INVENTION

### 2.1 IN VIVO NMR IMAGING: GENERAL CONSIDERATIONS

Nuclear magnetic resonance (NMR) is now widely used for obtaining spatial images of human subjects for clinical diagnosis. Clinical usage of NMR imaging, also called magnetic resonance imaging or, simply, MRI, for diagnostic purposes has been reviewed [see e.g., Pykett, et al., Nuclear Magnetic Resonance, pgs. 157-167 (April, 1982) and T.F.

35

Budinger, et al., Science, pgs. 288-298, (October, 1984)]. Several advantages of using such a procedure over currently used diagnostic methods, e.g., x-ray computer-aided tomography (CT), are generally recognized. For instance, the magnetic  
5 fields utilized in a clinical NMR scan are not considered to possess any deleterious effects to human health (see Budinger, supra., at 296). Additionally, while x-ray CT images are formed from the observation of a single parameter, x-ray  
10 attenuation, MR images are a composite of the effects of a number of parameters which are analyzed and combined by computer. Choice of the appropriate instrument parameters such as radio frequency (Rf), pulsing and timing can be utilized to enhance (or, conversely, attenuate) the signals  
15 of any of the image-producing parameters thereby improving the image quality and providing better anatomical and functional information. Finally, the use of such imaging has, in some cases, proven to be a valuable diagnostic tool as normal and diseased tissue, by virtue of their possessing different  
20 parameter values, can be differentiated in the image.

20 In MRI, the image of an organ or tissue is obtained by placing a subject in a strong external magnetic field and observing the effect of this field on the magnetic properties of the protons (hydrogen nuclei) contained in and surrounding  
25 the organ or tissue. The proton relaxation times, termed  $T_1$  and  $T_2$ , are of primary importance.  $T_1$  (also called the spin-lattice or longitudinal relaxation time) and  $T_2$  (also called the spin-spin or transverse relaxation time) depend on the chemical and physical environment of organ or tissue protons  
30 and are measured using the Rf pulsing technique; this information is analyzed as a function of distance by computer which then uses it to generate an image.

The image produced, however, often lacks definition and clarity due to the similarity of the signal from other tissues. To generate an image with good definition,  $T_1$  and/or  $T_2$  of the tissue to be imaged must be distinct from that of the background tissue. In some cases, the magnitude of these differences is small, limiting diagnostic effectiveness. Thus, there exists a real need for methods which increase or magnify these differences. One approach is the use of contrast agents.

10

## 2.2. MRI CONTRAST AGENTS

As any material suitable for use as a contrast agent must affect the magnetic properties of the surrounding tissue, MRI contrast agents can be categorized by their magnetic properties.

Paramagnetic materials have been used as MRI contrast agents because of their long recognized ability to decrease  $T_1$  [Weinmann et al., Am. J. Rad. 142, 619 (1984), Greif et al. Radiology 157, 461 (1985), Runge, et al. Radiology 147, 789 (1983), Brasch, Radiology 147, 781 (1983)]. Paramagnetic materials are characterized by a weak, positive magnetic susceptibility and by their inability to remain magnetic in the absence of an applied magnetic field.

Paramagnetic MRI contrast agents are usually transition metal ions of iron, manganese or gadolinium. They may be bound with chelators to reduce the toxicity of the metal ion (see Weinman reference above). Paramagnetic materials for use as MRI contrast agents are the subject of a number of patents and patent applications. (See EPA 0 160 552; UK Application 2 137 612A; EPA 0 184 899; EPA 0 186 947; US Patent 4,615,879; PCT WO 85/05554; and EPA 0 210 043).

35

Ferromagnetic materials have also been used as contrast agents because of their ability to decrease  $T_2$  [Medonca-Dias and Lauterbur, Magn. Res. Med. 3, 328, (1986); Olsson et al., Mag Res. Imaging 4, 437 (1986); Renshaw et al. 5 Mag Res. Imaging 4, 351 (1986) and 3, 217 (1986)]. Ferromagnetic materials have high, positive magnetic susceptibilities and maintain their magnetism in the absence of an applied field. Ferromagnetic materials for use as MRI contrast agents are the subject of recent patent applications 10 [PCT WO 86/01112; PCT WO 85/043301].

A third class of magnetic materials termed superparamagnetic materials have been used as contrast agents [Saini et al Radiology, 167, 211 (1987); Hahn et al., Soc. Mag 15 Res. Med. 4(22) 1537 (1986)]. Like paramagnetic materials, superparamagnetic materials are characterized by an inability to remain magnetic in the absence of an applied magnetic field. Superparamagnetic materials can have magnetic susceptibilities nearly as high as ferromagnetic materials and 20 far higher than paramagnetic materials [Bean and Livingston J. Appl. Phys. suppl to vol. 30, 1205, (1959)].

Ferromagnetism and superparamagnetism are properties of lattices rather than ions or gases. Iron oxides such as 25 magnetite and gamma ferric oxide exhibit ferromagnetism or superparamagnetism depending on the size of the crystals comprising the material, with larger crystals being ferromagnetic [G. Bate in Ferromagnetic Materials. vol. 2, Wohlfarth (ed.) p.439].

30 As generally used, superparamagnetic and ferromagnetic materials alter the MR image by decreasing  $T_2$  resulting in image darkening. When injected, crystals of these magnetic materials accumulate in the targeted organs or

35

tissues and darken the organs or tissues where they have accumulated. Abnormal volumes of liver, such as tumors, are deficient in their ability to take up the magnetic materials and appear lighter against normal background tissue than they would without contrast agent.

### 2.3 SUPERPARAMAGNETIC MATERIALS

As stated supra, superparamagnetic materials possess some characteristics of paramagnetic and some characteristics of ferromagnetic materials. Like paramagnetic materials, superparamagnetic materials rapidly lose their magnetic properties in the absence of an applied magnetic field; they also possess the high magnetic susceptibility and crystalline structure found in ferromagnetic materials. Iron oxides such as magnetite or gamma ferric oxide exhibit superparamagnetism when the crystal diameter falls significantly below that of purely ferromagnetic materials.

For cubic magnetite ( $\text{Fe}_3\text{O}_4$ ) this cut-off is a crystal diameter of about 300 angstroms [Dunlop, J. Geophys. Rev. 78 1780 (1972)]. A similar cut-off applies for gamma ferric oxide [Bare in Ferromagnetic Materials, vol. 2, Wohfarth (ed.) (1980) p. 439]. Since iron oxide crystals are generally not of a single uniform size, the average size of purely ferromagnetic iron oxides is substantially larger than the cut-off of 300 angstroms (.03 microns). For example, when gamma ferric oxide is used as a ferromagnetic material in magnetic recording, (e.g., Pfizer Corp. Pf 2228), particles are needle-like and about 0.35 microns long and .06 microns thick. Other ferromagnetic particles for data recording are between 0.1 and 10 microns in length [Jorgensen, The Complete Handbook of Magnetic Recording, p. 35 (1980)]. For a given



type of crystal, preparations of purely ferromagnetic particles have average dimensions many times larger than preparations of superparamagnetic particles.

5           The theoretical basis of superparamagnetism has been described in detail by Bean and Livingston [J. Applied Physics, Supplement to volume 30, 1205 (1959)]. Fundamental to the theory of superparamagnetic materials is the destabilizing effect of temperature on their magnetism. Thermal energy  
10 prevents the alignment of the magnetic moments present in superparamagnetic materials. After the removal of an applied magnetic field, the magnetic moments of superparamagnetic materials still exist, but are in rapid motion, causing a randomly oriented or disordered magnetic moment and, thus, no  
15 net magnetic field. At the temperatures of biological systems and in the applied magnetic fields of MR imagers, superparamagnetic materials are less magnetic than their ferromagnetic counterparts. For example, Berkowitz et al. [(J. App. Phys. 39, 1261 (1968))] have noted decreased  
20 magnetism of small superparamagnetic iron oxides at elevated temperatures. This may in part explain why workers in the field of MR imaging have looked to ferromagnetic materials as contrast agents on the theory that the more magnetic a material is per gram, the more effective that material should  
25 be in depressing  $T_2$  [Drain, Proc. Phys. Soc. 80, 1380 (1962); Medonca-Dias and Lauterur, Mag. Res. Med. 3, 328 (1986)].

#### 2.4.       WATER-BASED SUPERPARAMAGNETIC SOLUTIONS

30           It has been recognized for some time that superparamagnetic particles can be fashioned into magnetic fluids termed ferrofluids [see Kaiser and Miskolczy, J. Appl. Phys. 41 3 1064 (1970)]. A ferrofluid is a solution of very fine magnetic particles kept from settling by Brownian motion.

To prevent particle agglomeration through Van der Waals attractive forces, the particles are coated in some fashion. When a magnetic field is applied, the magnetic force is transmitted to the entire volume of liquid and the ferrofluid  
5 responds as a fluid, i.e. the magnetic particles do not separate from solvent.

Another approach to synthesizing water-based magnetic compounds is disclosed by Gable et al (U.S. Patent  
10 No. 4,001,288). Here, the patent discloses that magnetite can be reacted with a hydroxycarboxylic acid to form a water soluble complex that exhibits ferromagnetic behavior both in the solid form and in solution.

15           2.4.1. PROBLEMS MANIPULATING AQUEOUS SOLUTIONS OF SUPERPARAMAGNETIC MATERIALS

Approaches to the synthesis of aqueous fluids of superparamagnetic iron oxides often involve surrounding iron oxide crystals with polymer or surfactants in an effort to  
20 block the attractive forces between the crystals that promote aggregation. In many cases however, the polymer does not completely coat the oxide and the resultant material maintains much of the sensitivity to clumping or aggregation characteristic of the uncoated iron oxide. The tendency to  
25 clump, and other peculiar properties of iron oxide solutions, hamper the manipulations of these solutions needed in pharmaceutical manufacture.

The manufacture of a magnetic pharmaceutical  
30 solution such as an MRI contrast agent requires an extremely stable solution so certain manipulations, common in pharmaceutical manufacture, can be carried out. Solution stability is defined as the retention of the size of the magnetic material in solution; in an unstable solution the  
35

material will clump or aggregate. Such changes in the size of magnetic material alter its biodistribution after injection, an intolerable situation for an MRI contrast agent. A high degree of stability is required to perform common operations associated with pharmaceutical manufacture such as dialysis, concentration, filtration, centrifugation, storage of concentrates prior to bottling, and long term storage after bottling. Particular problems are posed by the need to sterilize aqueous solutions of metal oxide, e.g. iron oxide, for pharmaceutical use.

Additionally, concentrated solutions of aqueous superparamagnetic materials cannot be sterilized by filtration even when the solution is comprised of materials smaller than the pore of the filter. This phenomena is related to the concentration of the solution, for dilute solutions can be filter sterilized. Filter-sterilized, dilute material can be reconcentrated and dispensed into sterile bottles, but such operations offer many chances to recontaminate the product. Autoclaving solutions of superparamagnetic materials after bottling is preferable, since sterilization is achieved after final bottling, and there is little opportunity for contamination of the final product. Autoclaving involves heating sealed solutions to 121°C for 30 minutes. Such extreme temperatures induce aggregation or clumping of the superparamagnetic oxides, making them unusable as an injectable material.

## 2.5. PARAMAGNETIC FERRIC OXIDES

Paramagnetic iron oxides or ferric oxides are currently used in the treatment of anemia under many trade names such as Imferon. When dissolved in aqueous solution, such materials can be represented as  $\text{FeO}:\text{OH}$  and are termed

ferric oxyhydroxides. They are paramagnetic and exert small, if any, effects of proton relaxivity. They are stable, undergo the manipulations discussed supra for pharmaceutical manufacture, and are commercially available as drugs used in  
5 the treatment of anemia.

### 3. NOMENCLATURE

The term "biodegradable" in reference to the  
10 materials of this invention is defined as being metabolized and/or excreted by the subject within 30 days or less; for superparamagnetic iron oxides, the term is further defined as being incorporated into the hemoglobin of a subject within 30 days or less after administration.

15 The term "blocking agent" is defined as any material which when administered parenternally to a subject, will competitively bind to the receptors of the cells of the reticuloendothelial system which recognize and bind MRI  
20 contrast agents.

The term "superparamagnetic fluid" defines any metal  
oxide fluid produced by the methods described in section 6.3  
herein, which has the characteristics described in section 6.4  
25 herein.

### 4. SUMMARY OF THE INVENTION

It is an object of this invention to provide an in  
30 vivo MR imaging technique for diagnostic purposes which will produce a clear, well-defined image of a target organ or tissue. Specifically, it is an object of this invention to provide an imaging method using MR contrast agents which are easily administered, exert a significant effect on the  
35

image produced and which distribute in vivo to specific organs or tissues. These contrast agents are stable in vivo, can be easily processed for in vivo use, and overcome problems of toxicity and excessively long retention in the subject (i.e. are biodegradable). It is further an object of this invention to provide a means whereby these contrast agents can be directed, in vivo, to a specific target organ or tissue.

This invention provides a novel MR imaging method using biodegradable superparamagnetic metal oxides as contrast agents which fulfill the foregoing objectives. Such materials, it has been discovered, combine an optimal balance of features and are particularly well-suited for use as MR contrast agents. Remarkably, it has been found that these superparamagnetic materials exert a greater effect on  $T_2$  than ferromagnetic or paramagnetic materials, thereby producing a well-resolved, negative contrast image of an in vivo target organ or tissue. It has also been surprisingly found that the materials used in the methods of this invention exhibit highly desirable in vivo retention times, i.e., they remain intact for a sufficient time to permit the image to be taken, yet are ultimately biodegradable. Remarkably, once degraded, iron-based materials serve as a source of nutritional iron. Additionally, they are sufficiently small to permit free circulation through the subject's vascular system and rapid absorption by the organ/ tissue being imaged, allowing for maximum latitude in the choice of administration routes and ultimate targets.

In one embodiment, the materials used as MR imaging agents comprise superparamagnetic metal oxide particles which comprise superparamagnetic crystalline cores. Each core is composed of magnetically active metal oxides and can range from about 50 to about 500 angstroms in diameter. The cores

may be uncoated or, alternatively, coated with a polysaccharide, a protein, a polypeptide or any composite thereof. By way of illustration, the polysaccharide coating may comprise dextran of varying molecular weights and the protein coating may comprise bovine or human serum albumin. With coatings, the overall particle diameter ranges upward to about 5,000 angstroms. In the case of coated particles, the coatings can serve as a base to which various biological molecules can be attached. The biological molecules can be used to direct the particles to the desired target and are preferentially recognized and bound by the target organ or tissue. Such molecules include proteins, polysaccharides, hormones, antibodies, etc.

Preferred superparamagnetic particles comprise iron oxides with crystal sizes ranging from about 50 to about 500 angstroms. These iron oxide particles have surface areas greater than  $75 \text{ m}^2/\text{gram}$ . In aqueous solution, these iron oxide particles have a size range between about 50 and about 5,000 angstroms, including coatings, if any. The superparamagnetic iron oxides have magnetic saturations between about 5 and about 90 electromagnetic units (EMU) per gram of oxide at room temperature (approximately  $25^\circ\text{C}$ ) and possess a magnetic squareness of less than 0.10, i.e., lose greater than 90% of their magnetism when an applied magnetic field is removed.

Superparamagnetic particles with these general dimensions overcome problems associated with the use of ferromagnetic and paramagnetic materials as MR contrast agents. Specifically, superparamagnetic particles, because they are smaller than ferromagnetic particles, are more able to avoid uptake by the subject's reticuloendothelial cells and may be more effectively targeted to other organ and tissue sites within the body. Also, because the

superparamagnetic particles are smaller than ferromagnetic particles, they have higher surface area per unit mass and are more easily and rapidly digested by chemical or metabolic processes. However, the superparamagnetic particles used  
5 herein, because they are larger than paramagnetic ions, are not so rapidly metabolized in the target organ or tissue as to prevent convenient imaging.

Uncoated or coated particles may be suspended in an  
10 appropriate medium (e.g., saline) to form a particle dispersoid that has the properties of a solution. The particles do not settle upon standing and do not scatter visible light (i.e., the solution appears translucent). Solvent can be added (decreasing) or removed (increasing) particle  
15 concentration.

This dispersoid of particles may be administered to the subject being studied. Depending on the route of administration, the particles are distributed to various  
20 target organs, where absorption occurs. For example, when the superparamagnetic particles are administered intravascularly (e.g., intravenously or intra-arterially), they are selectively distributed to reticuloendothelial organs, including liver, spleen, lymph nodes and bone marrow  
25 and, to a lesser extent, lung. However, when the superparamagnetic particles are administered via the gastrointestinal tract, e.g., orally, by intubation or by enema, they can be used as imaging agents for the organs and tissues of the gastrointestinal tract.

30 The use of sub-micron sized particles is particularly important when the route of administration is intravascular, as such particles can freely circulate in the subject's vascular system, since they are small enough to

pass through the capillary network. Thus, such contrast agents can be carried to targeted organs or tissue after being intravascularly administered with a minimum of trouble or delay.

5

In one embodiment, a dextran-coated iron oxide particle dispersoid is injected into a subject's bloodstream and the particles localize in the liver. The particles are absorbed by the reticuloendothelial cells of the liver by phagocytic uptake; a particular benefit of this mode of uptake is that phagocytized iron is metabolized and cleared from the liver much more slowly (but not so slowly as to lead to undesirably long retention times) than prior art paramagnetic ions. Additionally, the dextran-coated particles can be preferentially absorbed by healthy cells, with less uptake into cancerous (tumor) cells. This preferential uptake enhances the contrast between healthy and cancerous tissue and allows for better definition of the tumor location on the image.

20

In another embodiment of this invention, the materials comprise stable, biodegradable superparamagnetic metal oxides, preferably ferric oxides, in the form of superparamagnetic fluids. These superparamagnetic fluids exhibit some of the magnetic properties of superparamagnetic ferrofluids (e.g., the metal oxides in them cannot be removed from solution by magnetic manipulation), yet the metal oxides in them can be easily be reclaimed from the bulk fluid by physical means (e.g. centrifugation) and, ultimately redispersed in the bulk fluid. When dispersed, the metal oxides will not scatter visible light, indicating the individual metal oxide "particles" are quite small (generally between 50 and 4000 angstroms in diameter.)

35



The metal oxides of the invention exist in the bulk fluid as ionic crystals, having both ionic and crystalline characteristics. In common with magnetite ( $\text{Fe}_3\text{O}_4$ ) and gamma ferric oxide (gamma  $\text{Fe}_2\text{O}_3$  they have high magnetic  
5 susceptibility. In common with ionic forms of ferric oxide the so-called ferric oxyhydroxides, they cause retention of anions. The counterion to the crystals can be any one of a number of organic anions.

10 In a preferred embodiment, the metal oxide is a superparamagnetic ferric oxyhydroxide and the counterion is citrate. The use of citrate counterions also confers a distinct advantage to the fluids as it renders them highly stable. In fact, the citrated fluids can withstand  
15 autoclaving greatly facilitating sterile administration.

The metal oxides in the superparamagnetic fluids may also be surrounded by a coating comprising a polysaccharide, a protein, a polypeptide, an organosilane, or any composite  
20 thereof. These polymeric coatings serve a dual purpose, helping to stabilize the superparamagnetic fluids as well as serving as a base to which biological molecules can be attached. These biological molecules can be used to direct particles to the desired target and are preferentially recog-  
25 nized and bound by the target organ or tissue. These molecules include proteins, polysaccharides, hormones, antibodies, etc.

The superparamagnetic fluids, whether comprised of coated or uncoated metal oxides, can be administered to a  
30 subject by any of the means described supra for the metal oxide dispersoids. Furthermore, in general the fluids are quite stable and can be prepared well in advance of use and stored.

35

The superparamagnetic fluids, containing both coated and uncoated metal oxides, are produced by a unique three step process from a mixture of  $\text{Fe}^{2+}$  and  $\text{Fe}^{3+}$  salts. In addition, this process permits incorporation of other metals similar to iron (such as cobalt (Co) and manganese (Mn)) into the fluids by replacing some of the divalent iron salts with divalent salts of these metals. In the process, the salts are precipitated in base to form the corresponding oxides. These oxides are then dispersed and oxidized by sonication of the mixture; the result, remarkably, is a superparamagnetic ferric oxyhydroxide. Insoluble oxides can then be removed by centrifugation and the final fluid is dialyzed against a neutral or alkaline buffer suitable for in vivo use.

In a preferred embodiment, the salt mixture is  $\text{FeCl}_2/\text{FeCl}_3$  in a 1:2 ratio and the buffer is 10mM ammonium citrate at pH 8.2. The result is a superparamagnetic fluid of unusual stability, characterized by its capacity to withstand autoclaving.

Once administered, both the metal oxides of the superparamagnetic particle dispersoids and the superparamagnetic fluids collect in the target organ or tissue and exert a profound contrast effect to permit an image to be taken. The superparamagnetic metal oxides act primarily to enhance  $T_2$  relaxation, but  $T_1$  is also affected (although to a lesser extent).

Another embodiment of this invention presents a method for extending the lifetime of the superparamagnetic metal oxides in the subject's serum. The method comprises administering a dose of paramagnetic metal oxide in the same form as the superparamagnetic imaging agent (i.e. appropriate particle size and, if applicable, the same coating) as a

blocking agent prior to the administration of the imaging agent. This blocking agent will compete with the imaging agent for binding to the reticuloendothelial system (RES) receptors. Since the RES is responsible for removing  
5 impurities from the blood, the binding of the blocking agent greatly increases the serum lifetime of the imaging agent. Potential applications of this procedure include, but are not limited to, use of MRI to diagnose blood circulation disorders and strokes.

10

#### 5. BRIEF DESCRIPTION OF THE FIGURES

FIG. 1 is a graphical representation comparing the effect of ferromagnetic and superparamagnetic contrast agents  
15 on  $T_2$ ;

FIG. 2 is a composite of five in vivo MR images of a cancerous rat liver obtained on a Technicare MR Imager;

20 FIGS. 2A and 2B were obtained without the use of contrast agents and were taken at different settings of instrument;

FIGS. 2C and 2D were obtained after the intravenous  
25 administration of the dextran-coated particle produced in Example 6.1. at a dosage of 0.5mg/kg; the tumor can clearly be seen;

FIG. 2E is the image reproduced in FIG. 2C showing  
30 the tumor highlighted by crosshairs;

35

FIG. 3 is a graphical representation of the %  $T_2$  reduction in liver and spleen tissue for three different dosages of an uncoated superparamagnetic particle as a function of time after administration;

5

FIG. 4 presents hysteresis curves for paramagnetic, ferromagnetic and superparamagnetic iron oxides;

FIG. 5 shows the effect of autoclaving on superparamagnetic fluids having varying concentrations of citrate;

10

FIG. 6 presents a schematic diagram of the apparatus used in example 7.10; and

15

FIG. 7 is a graphical representation of the  $T_2$  of rat blood as a function of time after the injection of a dextran-coated superparamagnetic iron oxide particle with and without the use of a blocking agent.

20

## 6. DETAILED DESCRIPTION OF THE INVENTION

### 6.1. PREPARATION OF COATED SUPERPARAMAGNETIC IRON OXIDE PARTICLES

25

The synthesis of superparamagnetic iron oxide particles for use as MRI contrast agents is accomplished by mixing ferrous and ferric salts with base to form a black, magnetic oxide of iron. Crystals result from such precipitations, for when the material is subjected to X-ray diffraction analyses long range order is apparent. A diameter of between about 50 and about 300 angstroms for such crystals has been calculated although crystals may range in diameter

30  
35

from about 50 to about 500 angstroms. The iron oxides have correspondingly high surface areas, greater than about 75 m<sup>2</sup>/gm.

5           The presence of ferrous salts prior to base addition insures the formation of a black, crystalline magnetic iron oxide. Without the ferrous ion, paramagnetic ferric oxide gels (noncrystalline materials) result (as described e.g., in U.S. Patent No. 2,885,393). The presence of  
10   divalent iron, so essential to the formation of the superparamagnetic material, can then be removed by exposure of the material to oxidizing conditions. Oxidation of the iron to produce a ferric oxide after formation of the crystal does not alter the usefulness of the material as a contrast  
15   agent in MRI or the superparamagnetism.

          It is to be understood throughout this detailed description, that the use of superparamagnetic iron oxides as MR contrast agents is but one embodiment of the invention and  
20   that superparamagnetic oxides of other magnetic metals, e.g., cobalt or gadolinium, may be substituted for iron oxides.

          There are two general strategies for the formation of the coated superparamagnetic iron oxide particles suitable  
25   for MRI.

1.   Synthesis of iron oxide by precipitation in the presence of polymers like dextran, or polyglutaraldehyde or other material. Such syntheses include those described by  
30   London et al., U.S. Patent No. 2,870,740, Molday, U.S. Patent No. 4,452,773, Cox et al., Nature, 208, 237 (1965) and Rembaum, U.S. Patent No. 4,267,234; all of which are incorporated herein by reference.

35

2. Synthesis of the iron oxide by precipitation followed by coating with a polymer like dextran or other material. This type of synthetic route is utilized by Elmore, Phys. Rev. 54, 309 (1938) and Ohgushi et al., J. Mag Res., 29, 599 (1978); both of which are incorporated herein  
5 by reference.

With proteins and dextrans, synthesis of the oxide in the presence of the polymer seems to effect a tight  
10 association between the polymer and the oxide. The synthesis of oxide first, followed by exposure to a protein or dextran yields a coated particle with the coating being held to the particle surface by relatively weak adsorption phenomena. However, if the oxide and adsorbed polymer can be  
15 manipulated, stored and injected in the presence of nonadsorbed polymer, the weakness of the association between oxide and polymer is not a problem. For example, when the particles of Section 6.1.3. (uncoated) are diluted 1:1 into a neutral buffer containing 1% w/v human serum albumin (HSA),  
20 considerable protein will adsorb to the oxide surface. This approach to the synthesis of an albumin coated magnetic particle is a practical one for an imaging agent. The HSA coated particle (plus HSA in solution) can be injected into a patient and the HSA in solution mixes with HSA in serum.  
25 When particles are made by this approach the loosely associated HSA can be removed by treatments such as moderate temperature (50°C) or high salt (1M NaCl).

The coating methods are general and can be  
30 performed with a variety of physiologically acceptable proteins and carbohydrates, particularly those with molecular weights from about 5,000 to about 250,000 daltons. Other



As mentioned above, various magnetically active metals notably Co, and Mn, may be substituted for Fe without any deleterious effect on the efficiency of the particles as contrast agents. Use of other polysaccharides such as starches, glycogen or dextrans is also contemplated.

#### 6.1.2. PREPARATION OF PROTEIN-COATED PARTICLES

Protein-coated superparamagnetic iron oxide particles are prepared by a single-step process similar to that of Molday [U.S. Patent 4,452,733]. The protein-coated particles can be prepared like the dextran coated wherein the iron salts (e.g.,  $\text{FeCl}_2$  and  $\text{FeCl}_3$ ) and the protein are dissolved in water and the coated iron oxide particles are precipitated by the dropwise addition of base ( $\text{NH}_4\text{OH}$ ) to pH=10. In an alternative embodiment the protein can be dissolved in the base and an aqueous solution of the iron salts can be added dropwise to form a coated particle.

In either method, the oversized particles are subsequently collected by centrifugation at 1500 x g and the remaining particles are subjected to dialysis against distilled water followed by ultrafiltration. Any unbound protein can be removed by gel filtration chromatography in a chloride/acetate buffer.

As with the polysaccharide coated particles, both the coating composition and the  $\text{Fe}^{3+}/\text{Fe}^{2+}$  ratio (about 2/1) can be varied from about 0.5:1 to about 4:1 without any deleterious effect on the efficiency of these particles as contrast agents.



As mentioned above, various magnetically active metals notably Co, and Mn, may be substituted for Fe without any deleterious effect on the efficiency of the particles as contrast agents.

5

### 6.1.3. PREPARATION OF UNCOATED PARTICLES

Uncoated FeO and Fe<sub>2</sub>O<sub>3</sub> superparamagnetic particles are prepared by mixing an aqueous solution of ferric chloride (FeCl<sub>3</sub>) with ferrous chloride (FeCl<sub>2</sub>) in HCl and precipitating in 0.7 molar aqueous ammonia. The base precipitation offers a dual advantage in that the base reacts with the iron chlorides to form uncoated superparamagnetic iron oxide particles. The precipitate (a gelatinous substance) is then collected by centrifugation or application of a magnetic field followed by decantation of the liquid phase.

The gel is then peptized to form a dispersoid by mixing with either 1 molar aqueous tetramethylammonium hydroxide (to form an alkaline dispersoid) or 2 molar aqueous perchloric acid (to form an acidic dispersoid) followed by centrifugation and redispersion in water. Both of these dispersoids show remarkable stability and, being colloidal in nature, will not possess large solid particles. The counterions, either tetramethylammonium hydroxide or perchlorate, are charged in basic or acidic media, respectively and, thus, prevent complex coagulation in solution; the particles (complexes of iron oxide/counterions) can be repeatedly precipitated and re-dispersed in solution and will retain this property.

35

In an alternative embodiment the particles can be collected by the application of an external magnetic field rather than centrifugation. The resultant magnetic cake is then peptized by the appropriate counterion.

5

The ratio of  $\text{Fe}^{3+}/\text{Fe}^{2+}$  is preferably maintained at about 2/1, but can be varied between about 0.5/1 and about 4/1. Decreasing the ratio will produce larger and increasing the ratio will produce smaller sized particles. Using the  
10 2/1 ratio and 0.7M  $\text{NH}_4\text{OH}$ , the average particle size produced is about 1200 angstroms as measured by light scattering.

#### 6.2. USE OF THE PARTICLES AS MR IMAGING AGENTS

15

The magnetic materials described above can be used as contrast-enhancing agents for in vivo MR imaging. In one embodiment, the particles are dispersed in a suitable injection medium, such as distilled water or normal saline, or any other physiologically acceptable carrier known in the  
20 art, to form a dispersoid which is introduced into the subject's vascular system by intravenous injection. The particles are then carried through the vascular system to the target organ where they are taken up.

25

When intravascularly administered, the particles will be preferentially taken up by organs which ordinarily function to cleanse the blood of impurities, notably the liver, spleen, and lymph nodes, and the other organs which tend to accumulate such impurities, notably bone and neural  
30 tissue and to some extent, lung. In each of these organs and tissues, the uptake into the reticuloendothelial cells will occur by phagocytosis, wherein the particles enter the individual cells in membrane-bound vesicles; this permits a longer half-life in the cells, as such membrane-bound parti-

35

cles will not tend to clump or aggregate (aggregates are rapidly metabolized and cleared from the organ/tissue). Other uptake mechanisms are possible, e.g., pinocytosis. Also, it is possible that the other cells of the liver (hepa-  
5 tocytes) may absorb the magnetic particles.

Because cancerous tumor cells can lack the ability of phagocytic uptake, the intravascularly administered particles can serve as valuable tools in the diagnosis of  
10 cancer in the above-mentioned organs, as tumors will be immediately distinguishable on any image obtained.

In a another embodiment, the particles are administered as dispersoids in a physiologically acceptable carrier,  
15 such as distilled water, into the gastrointestinal tract, which includes the esophagus, stomach, large and small intestine, either orally, by intubation, or by enema, in a suitable medium. The particles are preferentially absorbed by the cells of the tract, especially those of the intestine  
20 and, like the intravascularly introduced particles, will exert an effect on  $T_2$  of the organ or tissue. In this manner, cancers and other debilitating diseases of the digestive system such as ulcers can be diagnosed and affected areas pinpointed.

25  
Regardless of the route, once administered, the particles distribute to and collect rapidly in the target organs, generally in 30-minutes to an hour.

30  
In the organ, these superparamagnetic particles will alter the magnetic fields produced by the MR imager. These altered fields will exert an effect on the magnetic properties of the hydrogen nuclei (protons) in neighboring molecules; notably affected is the spin-spin relaxation time,  
35

$T_2$ . This parameter is shortened which can result in image darkening. Thus, the contrast is enhanced between areas which absorb the particles rapidly and those which absorb them slowly or not at all.

5

The particles are, however, ultimately biodegradable and the iron can be utilized by the body for physiological requirements. The contrast effect will vary with the dose, being longer at higher doses, and also with the organ imaged. Particularly in the liver and spleen (which store iron for physiological use) the effect can be observed for 14 days or more, (see Section 7.6), and, often, as long as 30 days.

15

The localization in these organs, which store iron for ultimate incorporation into hemoglobin, reveals that the iron oxide particles will ultimately serve as a source of metabolizable iron and, in fact, will be incorporated in the subjects hemoglobin. Thus, these materials can also be useful in the treatment of anemia.

20

The differences in parameter values are interpreted by computer and used to generate an image of the organ in question. In the cases, as mentioned above, where uptake occurs by phagocytic processes (notably the liver, spleen, lymph nodes, and bone and neural tissue and to some extent, lung) such an image will clearly and distinctly differentiate between cancerous and healthy tissue, allowing for tumor location. In other organs and/or in the diagnosis of other diseases, modifications of the coating of these particles by the attachment of various functional groups will stimulate uptake by the organ or cell of choice. For example antibodies to a particular tumor cell (e.g. lung carcinoma) can be

30

35

attached to the surface of a coated particle, stimulating uptake by that organ if such a cell is present. In this way, the method can serve a diagnostic tool for many diseases.

5

### 6.3. PREPARATION OF SUPERPARAMAGNETIC FLUIDS

The superparamagnetic fluids useful as imaging agents in this invention are preferably prepared in a three step process which comprises the steps of: formation of a  
10 superparamagnetic metal oxide; oxidation and dispersion of this oxide by sonication; and dialysis in buffer. This process yields stable biodegradable superparamagnetic metal oxides that owe their stability primarily to their anion retaining properties. The metal oxides may be uncoated or  
15 attached to organic coatings. Each of these steps is discussed separately below.

#### 6.3.1. FORMATION OF SUPERPARAMAGNETIC METAL OXIDE

20

Formation of the superparamagnetic metal oxide is accomplished by mixing the appropriate metal salts with a base. In a preferred embodiment, this is accomplished by mixing an aqueous solution or suspension of divalent and  
25 trivalent iron salts ( $\text{FeCl}_2/\text{FeCl}_3$ ) with a base such as sodium hydroxide (NaOH). In addition, metals similar in structure to iron, such as Co and Mn, can be incorporated into the ultimate superparamagnetic fluid by replacing a portion, preferably 1/2 or less, of the divalent iron salt with a divalent salt of  
30 that metal. The result is then a mixed metal oxide precipitate containing both ferrous and ferric oxides, as well as oxides of the divalent metal.

35

When iron salts are used the ratio of  $\text{Fe}^{3+}/\text{Fe}^{2+}$  can be varied from 1/4 to 4/1 and still produce usable product. Thus, a wide range of salt mixtures can be utilized.

5                   Once the salts are mixed with the base, a superparamagnetic metal oxide precipitate is formed. The use of a high concentration of reactants and an abrupt change in pH favors the formation of small superparamagnetic metal oxides. Such oxides are preferred for use in the subsequent  
10 steps of this process.

#### 6.3.2. DISPERSION AND OXIDATION

In the second process step, the superparamagnetic  
15 metal oxide prepared in 6.3.1. is dispersed and oxidized further by sonication. The sonication, which can be conducted at ambient or elevated temperatures (up to 100°C) serves a dual purpose: it serves to disperse any clusters of superparamagnetic particles (which increases the ultimate  
20 effects of the material on proton relaxation and, hence, enhances their effectiveness as MR contrast agents) and, additionally, it serves to oxidize most, if not all, of ferrous oxide ( $\text{Fe}^{2+}$ ) to ferric oxide ( $\text{Fe}^{3+}$ ). The resultant material, remarkably, is a soluble superparamagnetic iron  
25 oxyhydroxide which forms a superparamagnetic fluid.

The sonication can be accomplished in any commercial apparatus including in a continuous flow sonicator or by a sonic probe. The former is especially useful when large  
30 volumes of materials are being handled and, for a continuous process, can be coupled with a heating and cooling apparatus to permit heating of the iron oxide prior to or after

sonication (to increase the dispersion and oxidation of the oxides) and subsequent cooling of the sonicated mixture to facilitate collection.

5

### 6.3.3. DIALYSIS

The final step in the process is the transfer of the solution to an aqueous polycarboxylic buffer suitable for in vivo use. This transfer is accomplished by dialyzing the fluid against the buffer at neutral pH, generally at a pH of 6-9, preferably 6-8.3. These conditions result in a stable superparamagnetic fluid; under acidic conditions (below a pH of about 6) a significant amount of a chelate of the iron begins to form rather than the superparamagnetic iron oxide.

15

In the process, the fluid from 6.3.2. is centrifuged, to remove larger oxide aggregates, and the supernatant is dialyzed against the buffer. The preferred buffer contains a citrate salt, because of its suitability for in vivo use and its long history as an injectable agent, but in general buffers containing salts of any polycarboxylic acid, (such as tartrate, succinate) or maleate, allow for the formation of stable superparamagnetic fluids. The resultant fluids can then be autoclaved and stored until needed.

20

### 6.3.4. PREPARATION OF STABLE SUPERPARAMAGNETIC FLUIDS CONTAINING METAL OXIDES WITH ORGANIC COATINGS

Superparamagnetic fluids containing metal oxides to which organic coatings are attached can be prepared by modifications of the above procedure. Such organic coatings can be selected from a wide array of polymeric materials including, but not limited to, carbohydrates such as dextran (preferably having a molecular weight between 5,000 and

35

250,000 daltons), proteins (preferably having a molecular weight between 5,000 and 250,000 daltons) such as bovine or human serum albumen, polypeptides (preferably having molecular weights between 5,000 and 250,000 daltons) such as polylysine and polyglutamates and organosilanes (preferably having a molecular weight between 5,000 and 250,000 daltons) such as N-2-aminoethyl-3-aminopropyltrimethoxysilane. Briefly, the attachment can be accomplished during either the first or the second steps.

5  
10

When attachment is accomplished during the first step, the coating material is mixed with the salt solution prior to the supermagnetic metal oxide precipitation. The coating material is attached to the resultant precipitate, and remains attached during the subsequent steps. Any unbound coating agent is removed during dialysis (step 3). In a preferred embodiment, superparamagnetic fluids containing dextran-coated iron oxides can be formed in this manner.

15

The attachment can also occur during the dispersion and oxidation second step by adding the coating agent prior to the sonication and subsequently sonicating the mixture to form the corresponding oxyhydroxide. Again, the unbound coating agents are removed by dialysis.

20  
25

Superparamagnetic fluids containing silanized iron oxides are prepared in a similar manner. Initially, the iron oxides are subjected to sonication to form the oxyhydroxides. The organosilane is then added and the mixture is sonicated to disperse the materials. Finally, the silane is attached to the surface via a dehydration reaction. The polymerization of the silane may occur before or after the deposition on the oxyhydroxide surface.

30  
35



In one embodiment, the silanization reaction occurs in two steps. First, a trimethoxysilane is placed in the sonicated mixture which condenses to form silane polymers:

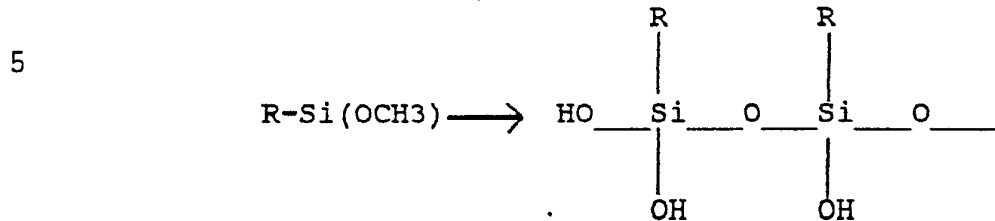

10 The mixture is then sonicated, after which these polymers associate with the metal oxide, presumably by forming a covalent bond with surface OH groups through dehydration:

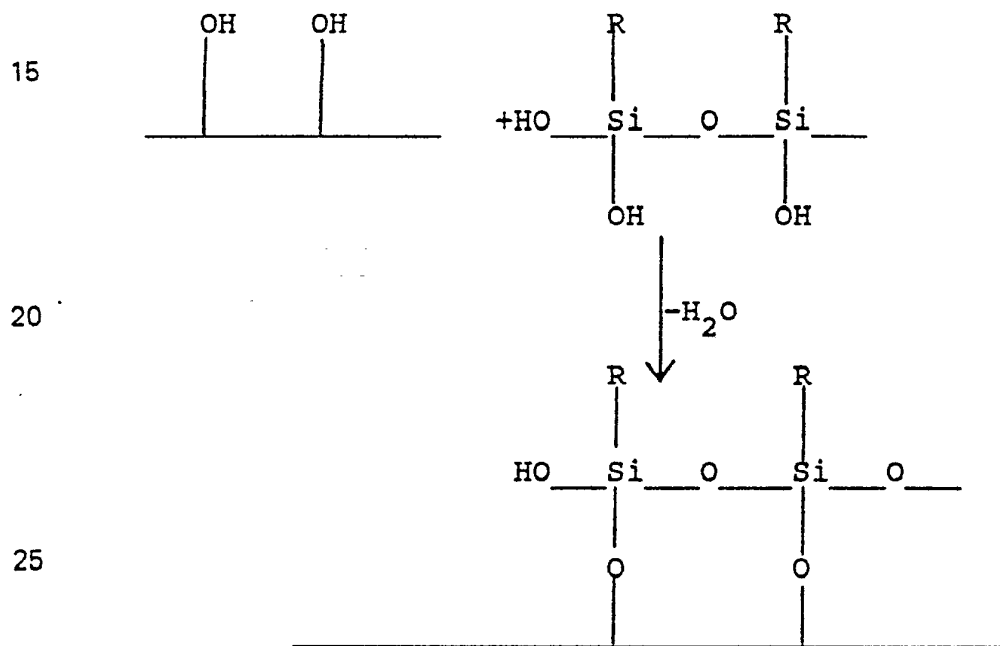

30 Adsorption of silane polymers to the metal oxide is also possible.

An important aspect of this procedure is the method of dehydration used to effect the adsorptive or covalent binding of the silane polymer to the metal oxide. This association is accomplished by heating the silane polymer and

35

metal oxide in the presence of a wetting agent miscible in both the organic solvent and water. Glycerol, with a boiling point of about 290°C., is a suitable wetting agent. Heating to about 105°C in the presence of glycerol serves two purposes. It insures the evaporation of water, the organic solvent (which may be e.g., methanol, ethanol, dioxane, acetone or other moderately polar solvents) and any excess silane monomer. Moreover, the presence of glycerol prevents the aggregation or clumping and potential cross linking, of particles that is an inherent problem of other silanization techniques known in the art wherein dehydration is brought about by heating to dryness. Thus, few aggregates are formed. Any formed aggregates are removed by centrifugation and the unbound silane is removed by hydrolysis.

15

#### 6.3.5. ADVANTAGES OF THE SUPERPARAMAGNETIC FLUID PREPARATION PROCESS

The process used to prepare the superparamagnetic fluids of this invention is uniquely suited for preparing magnetic fluids suitable for in vivo use. Specifically, the following advantages are noted:

20

1. At no time is the material dried, nor is it precipitated after the initial formation of the superparamagnetic oxides. Such operations bring particles into close proximity with each other resulting in clustering and aggregation, which adversely affects their utility as MR contrast agents. Further, at no time are the metal oxides removed from superparamagnetic fluid by precipitation or filtration; in fact, they cannot be so removed. In dilute concentrations, the metal oxides will pass through a 0.22 micron filter.

30

35

2. Because the material is never precipitated (after the initial formation of the iron oxide), acids or bases are not needed to resolubilize the iron oxide. Use of acids tends to dissolve iron oxides, yielding ferric ion which is toxic and must be removed prior to in vivo use. Strong bases are also poorly suited for use in the preparation of pharmaceutical solutions of superparamagnetic fluids. Strong bases can hydrolyze biological molecules attached to iron oxides such as proteins or polysaccharides. Amine-containing strong bases can react with polysaccharides in the well known Malliard reaction.

3. Changes in solvents, such as to citrate buffer, are accomplished by dialysis. Many other methods (such as that described in U.S. Patent 4,001,288) of iron oxide preparation require removal of iron oxides from solution to accomplish changes in solvent, often using acid or base to resolubilize the precipitate.

4. The attachment of coating materials to the particles during the preparation permits a wide array of biologically active molecules such as antibodies, antigens, serum proteins or other materials to be attached. The attached biologically active molecule can serve to direct the superparamagnetic agent in vivo, as described in section 6.5.

#### 6.4. CHARACTERSTICS OF SUPERPARAMAGNETIC FLUIDS

##### 6.4.1. MAGNETIC PROPERTIES

The fluids produced by the methods described in section 6.3. are characterized by a high magnetic moment in a high magnetic field (generally, about 5 to about 90 EMU/gm of metal oxide) and a negligible magnetic moment in the

absence of an applied field (i.e., a magnetic squareness of less than 0.1). Such behavior is characteristic of superparamagnetic particles.

5           FIG. 4 shows magnetic hysteresis loops for typical  
paramagnetic, superparamagnetic and ferromagnetic iron oxides. Magnetization was measured in a vibrating sample magnetometer with fields up to 6,000 Gauss, 25°C. At high magnetic fields,  
10 the superparamagnetic fluid of the invention is nearly as  
magnetic as ferromagnetic iron oxide and far more magnetic  
than the paramagnetic ferric oxyhydroxide. Also, the  
solutions of the invention are superparamagnetic rather than  
ferromagnetic, losing virtually all of their magnetic moment  
in the absence of an applied magnetic field. In fact, the  
15 superparamagnetic solutions of this invention are  
characterized by a saturation magnetization of 30 EMU/gm or  
greater, with the loss of more than 90% of this magnetism in  
the absence of a magnetic field.

20                           6.4.2. RETENTION OF CITRATE AND  
STABILITY OF SUPERPARAMAGNETIC FLUIDS

The retention of citrate (from aqueous sodium, potassium, or ammonium citrate buffer) can be used to  
25 distinguish the superparamagnetic fluids of this invention  
from other iron oxides. Studies of citrate binding capacity  
of commercially available forms of iron oxides and ferric  
oxyhydroxides reveals that the iron oxides in the  
superparamagnetic fluids of this invention are capable of  
retaining nearly as much citrate as the paramagnetic (ionic)  
30 ferric oxyhydroxide, while gamma ferric oxide and magnetite  
cannot retain significant amounts of citrate. The inability  
of iron oxides to retain citrate, coupled with the ability of  
ferric oxyhydroxide to do so, strongly suggest that citrate  
does not adsorb to the surfaces of iron oxides prepared  
35 according to the method of this invention (see Section 6.3)

through the usual chemical adsorption mechanism. The retention of anions like citrate by the superparamagnetic iron oxides of the invention indicates these materials have an ionic character similar to the ferric oxyhydroxides.

5

The stability of fluids of the invention is shown in FIG. 5, where a superparamagnetic fluid made according to the procedure described in section 6.3. was subjected to autoclaving with and without citrate. Addition of 50 mM citrate stabilized a solution of 1.26 M iron oxide, preventing the gellation of the material.

The stability of the oxyhydroxide solutions of iron (i.e., the superparamagnetic fluids) is related to the exchange of hydroxide for citrate ion. Both paramagnetic and superparamagnetic oxides retain citrate in a similar fashion:

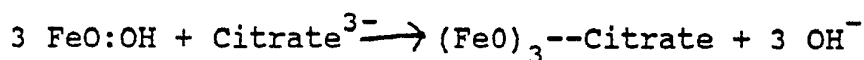

Instead of trying to block the Van der Waals forces between neutral crystals with polymers, by attaching surfactants, or forming complexes, the general approach used by others in forming ferrofluids, the invention's superparamagnetic fluids are stabilized due to the ionic character of the iron oxide and the choice of appropriate anions.

The stable solutions of this invention comprise a metal concentration ranging from 0.05 to 5 molar and a citrate ion concentration of 0.001 to 0.1 moles of citrate/mole preferably 0.01 to 0.1 moles of citrate/mole of iron at a pH ranging from about 6 to about 10. As the concentration of

35

iron in the solution is increased, the ratio of citrate/iron must also increase to yield the stability. Thus, they are compatible with physiological conditions.

5           The superparamagnetic fluids of the invention owe their stability in solution, not to their coating with polymers or surfactants, but to the existence of a cationic character of the iron oxide and its stabilization with anions such as citrate. In general, polymeric coatings, though they  
10 help stabilize iron oxides, are not sufficient to protect them against the rigors of autoclaving. In contrast, superparamagnetic fluids made according to the invention can be made omitting the polymer altogether and are highly stable.

15                           6.4.3. EFFECTIVENESS AS MR CONTRAST AGENTS

          In evaluating magnetic materials as MR contrast agents, the ability of materials to shorten proton relaxation time can be more important than bulk magnetic properties such  
20 as magnetization. Since MR imaging works by determining the rates of two types of proton relaxations in various tissues and, by using variations in those relaxation rates, develops an image, the differences in proton relaxation times between the tissues must be sufficiently great to obtain a good  
25 quality image. As stated supra, MR contrast agents work by shortening proton relaxation time and, thus, increases the contrast and overall image quality. Two relaxation parameters termed spin-spin relaxation time ( $T_1$ ) and spin-lattice relaxation time ( $T_2$ ) are used in the generation of the MR  
30 image.

          In experiments evaluating the effect of these materials as contrast agents, it was found that the superpara-  
magnetic fluids have a much greater effect on both  $T_1$  and  $T_2$

35

than any commercially available iron compounds including chelated ferric ion, paramagnetic ferric oxyhydroxides, gamma ferric oxides, and superparamagnetic iron oxide clusters (Example 7.15). In fact, the material of the invention is remarkable in its ability to shorten proton relaxation. The materials prepared according to the invention are more potent enhancers of proton relaxation than either ferromagnetic materials or paramagnetic ferric oxyhydroxide. In addition, the highly dispersed state of the materials of the invention produces higher relaxivities than those characteristic of clustered materials (See 7.12 and Table III). The process, thus, yields superparamagnetic solutions optimized for their effects on proton relaxation time.

The high relaxivity (see Table III) of the materials of the invention is important to their pharmaceutical use as MR contrast agents, because it results in large effects on the MR image with small doses of iron. For example, superparamagnetic iron oxides made according to the invention can profoundly improve liver imaging at doses of 1 mg of iron per kilogram of rat, while the LD50 for the rat is greater than 250 mg of iron per kilogram.

#### 6.5. BIODEGRADABILITY

Both the superparamagnetic particles in the dispersoids and the metal oxides in the superparamagnetic fluids of the invention have been found to be biodegradable when administered in vivo (see Examples 7.6 and 7.15). In fact, iron, the predominant species in the dispersoids and fluids accumulate in the liver, where it is eventually catabolized and incorporated into the subject's hemoglobin. Thus, the dispersoids and fluids can be used in the treatment of anemia, and indeed, the fluids have been shown to be as

effective as Imferon (a commercially used preparation for treatment of anemia in humans) in the restoration of normal hematocrit levels in anemic rats.

5

#### 6.6. DIRECTABILTY

Both the superparamagnetic particles in the dispersoids and the metal oxides in the superparamagnetic fluids of the invention can be coated with various coating agents as described supra. The use of such coatings permits the attachment of various biological molecules to the imaging agents to permit targeting of various organs. For example, antibodies can be bound by a variety of methods including diazotization and attachment through a glutaraldehyde or carbodiimide coupling moiety (Examples of these coupling methods can be found in U.S. Patent No. 4,628,037, which is incorporated herein by reference). Use of methods such as these permits maximum flexibility, as an antibody-directed superparamagnetic metal oxide can bind to a specific type of cell or tissue. This can permit an image to be generated which differentiates between the target and the surrounding tissue.

In addition to antibodies, other biological molecules which affect directability can also be attached to the particles as the particular application dictates. Some possible applications are listed below:

	<u>Antibodies</u>	<u>Application</u>
30	1. Anti-heart myosin	Imaging infarcted area of heart
	2. Anti-fibrin	Image clot
	3. Anti-T-cells	Lymphoma
	4. Anti-CEA	Colonic tumor imaging

35



- |   |                                   |                         |
|---|-----------------------------------|-------------------------|
| 5 | 5. Anti-melanoma antibodies       | Melanoma imaging        |
|   | 6. Anti-ovarian cancer antibodies | Ovarian cancer imaging  |
| 5 | 7. IgG                            | Fc receptor delineation |

#### Carbohydrates

- |    |  |  |
|----|--|--|
| 10 | 1. Bacterial lipopolysaccharides   |  |
|    | 2. Cellulose   |  |
|    | 3. Mucopolysaccharides   |  |
|    | 4. Starch  |  |
| 15 | 5. Modification of carbohydrate after synthesis, e.g., dextran coating made positively or negatively charged, diethylamino (DEAE) cellulose or carboxymethyl (CM) dextran. |  |

#### Hormones

#### Application

- |    |                                    |   |
|----|------------------------------------|---|
| 20 | 1. Insulin                         | Insulin receptor status as in maturity onset diabetes |
|    | 2. Thyroid stimulating hormone     | Thyroid disease                                       |
| 25 | 3. Acetylcholine (or analogs)      | Delineation of neural receptors                       |
|    | 4. Serum low density lipoprotein   | Delineation of familial hypercholesterolemia          |
| 30 | 5. Hormone analogs including drugs | Delineation of endocrine system and receptors         |
|    | 6. Serum transferrin               | Transferrin receptors delineation                     |

6.7 METHOD FOR EXTENDING THE SERUM  
LIFETIME OF AN MR IMAGE CONTRAST AGENT

5           To extend the lifetime of an MR imaging agent in the  
serum of a subject, if desired, it is necessary to prevent  
its absorption by the reticuloendothelial system (RES). It  
has been found that this can be accomplished by introducing to  
10 the subject a blocking agent which effectively competes with  
the imaging agent for binding the RES receptors responsible  
for removing the MR contrast agent from the bloodstream.  
There are a number of phagocytic receptors which function  
independently of each other. As a result, no single material  
is equally effective at blocking all the RES receptors and any  
15 blocking agent must be specific for the imaging agent. (See  
Davis et al. in "Polymeric Nanoparticles and Microspheres",  
Gurot, P. and Covreur, P., eds, (CRC Press, 1986) p. 180).

          In the procedure, the subject is given a dose of  
20 paramagnetic iron oxide either prior to or along with the  
administration of the imaging agent. For the best results,  
the paramagnetic iron oxide should be as similar to the agent  
as practical especially in particle size and coating. After a  
short time interval, generally 15-20 minutes during which time  
25 the paramagnetic material circulates in the bloodstream and  
binds to the RES receptors, the imaging agent is administered.  
By proper choice of the paramagnetic dosage, the lifetime of  
the imaging agent in the serum is greatly enhanced.

30           An excellent blocking agent for a superparamagnetic  
MR agent is a paramagnetic form of the same material. This is  
because the effectiveness of a blocking agent depends on  
whether a competition for receptors results; cell surface  
receptors bind materials in circulation prior to  
35 internalization. This internalization is termed pinocytosis

(removal of liquids) or phagocytosis (removal of particles). If competition is created, which blocks removal of the superparamagnetic MR contrast agent, the removal of the contrast agent will be hindered. Because the RES receptors  
5 are specific and will bind substances of only one particular size or shape, this competition is best observed among materials which are physically similar. Since a paramagnetic particle can differ from a superparamagnetic particle only in its core magnetic properties and rather than its surface  
10 chemistry, a high degree of competition is inevitable and, thus, the paramagnetic material is a highly efficient blocking agent.

In a preferred embodiment, dextran-coated  
15 paramagnetic iron oxide is used as a blocking agent for dextran coated superparamagnetic iron oxide. This material is ideal as a blocking agent for dextran-coated superparamagnetic iron oxide contrast agents for the reasons below:

20 1. It is virtually undetectable by MR.

2. It can be made by the process used for super-  
paramagnetic materials, but without the use of divalent iron,  
(which is required for the superparamagnetic product). The MR  
25 contrast agent and blocking agent are identical except for the fine structure of the iron oxide which determines magnetism and detectability by MR. From the point of view of the cell surface receptor governing removal from circulation the superparamagnetic imaging agent and blocking agent are  
30 identical.

3. It is non-toxic in humans and has an established therapeutic use in the treatment of anemia. In fact, therapeutically approved paramagnetic dextran (Imferon) can be used as a blocking agent for the superparamagnetic MR contrast agents of the invention.

The extension of serum lifetime is of particular importance when MR measurements are used to confirm blood circulation (or lack thereof). In such measurements, the contrast agent is introduced parenterally and permitted to circulate. By measurement of  $T_1$  and  $T_2$ , presence or absence of blood circulation can be determined. Such a procedure can be a valuable tool in the diagnosis of blood circulation disorders, and can be used to detect the flow of blood into areas where it is normally excluded, such as in strokes.

## 7. EXAMPLES

### 7.1. PREPARATION OF DEXTRAN-COATED PARTICLES

To a solution of 500 mls of 0.28M  $FeCl_3$ , 0.16M  $FeCl_2$  and 12.5% w/v dextran, (molecular weight 71,000 daltons from Sigma Chemical Company, Cat. #D1390) is added 500 mls 7.5%  $NH_4OH$  over a 2 minute period. A black, magnetic solid forms comprised of large and small particles. The material is stirred for 5 minutes and then heated for 30 minutes at 70°C. The solution is centrifuged for 1500 x g for 15 minutes to remove large particles, and the small particles are dialyzed against 10 gallons of  $H_2O$  for three days, changing the water each day.

The resultant particles exhibit a diameter of about 1400 angstroms as measured by light scattering.

### 7.2. Preparation of Particles Coated with Bovine Serum Albumin

To a solution of 80 mls of 0.5% bovine serum albumin (BSA), 0.27M FeCl<sub>3</sub>, and 0.16M FeCl<sub>2</sub>, is added 80 mls of 7.5% NH<sub>4</sub>OH. A black, magnetic solid forms comprised of particles. The mixture is allowed to stand for 5 minutes and then centrifuged at 1,500 x g for 15 minutes to remove larger particles. The pellet is discarded and the supernatant placed in a dialysis bag and dialyzed against 3 changes of 10 gallons of distilled water. Larger particles are again removed by centrifugation as above and discarded. Particles are then concentrated by ultrafiltration using an XM-50 membrane and a stirred cell filtration device from Amicon Corporation, Lexington, MA.

The resultant particles exhibit a diameter of about 1730 angstroms as measured by light scattering.

### 7.3. PREPARATION OF UNCOATED PARTICLES

One hundred milliliters of solution of 0.8M FeCl<sub>3</sub>, 0.4M FeCl<sub>2</sub> and 0.4M HCl is added dropwise to 1000 ml of 2.4% NH<sub>4</sub>OH and mixed for 5 minutes. A black, magnetic solid forms comprised of easily visible particles. For particles to be visible, they must be larger than the wavelength of scattered light which is about 500 nm (0.5 microns). The particles are isolated by attracting them to a permanent magnet on the outside of the reaction vessel and the solution decanted. To the magnetic cake is added 55 mls of 50% triethylamine in water. Smaller particles are created. The mixture is dialyzed overnight against water which causes the large particles to reappear. Just enough triethylamine is then added to again create the smaller particles resulting from the

addition of triethylamine. The particles are then filtered through a 0.2 micron filter indicating the final material is below this size.

5           7.4.    USE OF PARTICLES  
              IN LIVER TUMOR VISUALIZATION

              The effect of the dextran-coated particles of Section 7.1. on the image of a rat liver tumor is demonstrated in FIG. 2, which presents reproductions of five images  
10           obtained on a Technicare MR imager. The images in FIGS. 2A and 2B were obtained prior to the introduction of the imaging agent using different imager settings, in neither case can the tumor be clearly seen; FIGS. 2C and 2D are images of the same  
15           rat liver and were obtained after a single 0.5mg/kg dose of the Section 6.1. dextran-coated particle by intravenous injection through the tail vein, the tumor is easily seen and the overall size and shape can be gauged; in FIG. 2E the tumor is marked by cross-hairs to aid in visualization.

20           7.5.    COMPARATIVE EFFECT OF SUPERPARAMAGNETIC  
              PARTICLES AND FERROMAGNETIC PARTICLES ON T<sub>2</sub>

              FIG. 1 compares the T<sub>2</sub> of agar gel in the presence of dextran-coated particles (produced in Example 7.1.) and the  
25           ferromagnetic particle Pf-2228 (Pfizer). The relaxation times in the presence of varying concentrations of each particle were determined on an IBM PC-20 NMR spectrometer at 0.47 Tesla (4700 Gauss). It can clearly be seen that the  
30           superparamagnetic particle produces a much greater effect on T<sub>2</sub> than the ferromagnetic particle. Given the fact that superparamagnetic materials are much less magnetic than ferromagnetic materials, this result is quite surprising.

#### 7.6. BIODEGRADABILITY OF DEXTRAN-COATED PARTICLES

A dispersion of uncoated superparamagnetic iron oxide particles in water was intravenously injected into  
5 Sprague-Dawley rats at a dosages 20, 37 and 243 micromoles Fe/kg of body weight. Periodically, the rats were sacrificed, and  $T_2$  of the liver tissue was measured on an IBM PC-20 NMR Spectrometer. The results are presented in FIG. 3.

10 The data demonstrate that  $T_2$  undergoes a marked drop rapidly after the injection, and then begins to recover slowly, presumably as the iron is metabolized. However, the effects are still detectable even two weeks after  
administration. Also, the effects are more marked with the  
15 higher dosages. Thus the particles have an extended lifetime in these organs. Since the liver and spleen are the major organs which store iron for incorporation into hemoglobin, it is postulated that these materials are incorporated into the hemoglobin of the rat.

20

#### 7.7. BIODISTRIBUTION OF BSA-COATED PARTICLES

Six Sprague-Dawley rats of about 200 gm each were injected intravenously with 0.4 mg of the BSA-coated particle  
25 (produced in Section 7.2.) in distilled water. Two rats each were sacrificed at 90 minutes, 24 hours, and 7 days after injection and the relaxation times ( $T_1$  and  $T_2$  of various organs were measured on an IBM PC-20 NMR Spectrometer. The following results were obtained:

30

35

TABLE I

DISTRIBUTION OF BSA-COATED PARTICLE IN RAT ORGANS AND TISSUES

5	Time After Injection		Relaxation Times (msec)			
			<u>Liver</u>	<u>Spleen</u>	<u>Lung</u>	<u>Blood</u>
	Control	T <sub>1</sub>	0.279	0.544	0.688	0.786
	N <sup>1</sup> = 6	T <sub>2</sub>	32	48.3	57	158
10	90 min	T <sub>1</sub>	0.232	0.396	0.656	0.901
		N = 2	T <sub>2</sub>	20	22	56
15	24 hours	T <sub>1</sub>	0.279	0.494	0.735	1.084
		N = 2	T <sub>2</sub>	22	44	68
	7 days	T <sub>1</sub>	0.268	0.572	0.712	0.972
		N = 2	T <sub>2</sub>	31	49	68

20 <sup>1</sup> N is the number of rats examined.

The data suggest that both the blood and the lung rapidly clear the magnetic material exhibiting nearly no effect on the relaxation times 90 minutes after the injection. The spleen demonstrates a moderately rapid recovery, exhibiting a substantial reduction in both T<sub>1</sub> and T<sub>2</sub> 90 minutes after the injection, but nearly no residual effect after 24 hours. The liver exhibits two different recovery rates. T<sub>1</sub> attains its original value after 24 hours, while T<sub>2</sub> remains substantially reduced after 24 hours and exhibits recovery after 7 days.



7.8. COMPARATIVE BIODISTRIBUTION OF UNCOATED AND DEXTRANIZED PARTICLES

In this experimental series, the biodistribution of three uncoated and four dextran-coated particles was examined. The uncoated agents were produced according to the procedure of Section 7.3., the dextran-coated particles were produced according to the procedure of Section 7.1. except that the molecular weight of the dextran used for the coating was varied (see TABLE II). Prior to each experiment, the contrast agents were dialyzed against distilled water and subsequently injected into separate groups of Sprague-Dawley rats in a distilled water carrier. The rats were periodically sacrificed and the relaxation times of the liver, spleen, and lung were determined on an IBM PC-20 NMR Spectrometer. Preprogrammed inversion recovery and Carr, Purcell, Meiboom, Gill pulse sequences were used to determine  $T_1$  and  $T_2$ , respectively.

The results were as follows:

TABLE II

<u>Complex</u>	<u>Coating</u>	<u>Dose</u>	<u>Time After Dose</u>	<u>Relaxation Times (msec.)</u>		
				<u>Liver</u>	<u>Spleen</u>	<u>Lung</u>
Control	-	None	- $T_1$	0.27	0.54	0.717
			$T_2$	32	48	64
AMI-12	None	24.2 $\mu$ moles/ kg	2.5 hr. $T_1$	0.222	0.420	0.626
			$T_2$	22.7	26.0	45.8

	<u>Complex</u>	<u>Coating</u>	<u>Dose</u>	<u>Time After</u> <u>Dose</u>	<u>Relaxation Times</u> (msec.)		
					<u>Liver</u>	<u>Spleen</u>	<u>Lung</u>
5				18 hr. T <sub>1</sub>	0.254	0.532	0.752
				T <sub>2</sub>	29.6	42.9	68.2
				1 wk. T <sub>1</sub>	0.239	0.528	0.730
10				T <sub>2</sub>	31.6	43.8	72.0
				2 wk. T <sub>1</sub>	0.240	0.462	0.702
				T <sub>2</sub>	29.4	35.5	79.5
15	AMI-13	None	24.6 $\mu$ moles/ kg	2.5 hr. T <sub>1</sub>	0.221	0.424	0.672
				T <sub>2</sub>	16.9	28.0	65.2
				18 hr. T <sub>1</sub>	0.218	0.386	0.802
				T <sub>2</sub>	18.8	29.0	80.8
20				1 wk. T <sub>1</sub>	0.236	0.443	1.753
				T <sub>2</sub>	26.0	38.5	80.4
				2 wk. T <sub>1</sub>	0.236	0.493	0.722
25				T <sub>2</sub>	28.2	43.8	80.8
	AMI-14	None	25.4 $\mu$ moles/ kg	2 hr. T <sub>1</sub>	0.238	0.470	0.706
				T <sub>2</sub>	20.8	31.8	72.4
30				18 hr. T <sub>1</sub>	0.238	0.436	0.750
				T <sub>2</sub>	20.4	34.7	69.6
35							

	<u>Complex</u>	<u>Coating</u>	<u>Dose</u>	Time After <u>Dose</u>	<u>Relaxation Times</u> (msec.)		
					<u>Liver</u>	<u>Spleen</u>	<u>Lung</u>
5				1 wk. T <sub>1</sub>	0.216	0.522	0.755
				T <sub>2</sub>	26.7	41.7	80.4
				2 wk. T <sub>1</sub>	0.227	0.452	0.698
				T <sub>2</sub>	24.8	43.6	78.7
10	AMI-15	Dex-	36.8	4 hr. T <sub>1</sub>	0.238	0.300	0.672
		tran	$\mu$ moles/	T <sub>2</sub>	17.8	19.4	56.4
		9,000	kg	24 hr. T <sub>1</sub>	0.253	0.387	0.740
15				T <sub>2</sub>	21.1	26.4	73.2
				1 wk. T <sub>1</sub>	0.219	0.485	0.766
				T <sub>2</sub>	25.6	36.7	78.1
20				2 wk. T <sub>1</sub>	0.258	0.523	0.718
				T <sub>2</sub>	28.7	39.1	69.9
	AMI-16	Dex-	32.4	4 hr. T <sub>1</sub>	0.248	0.302	0.678
		tran	$\mu$ moles/	T <sub>2</sub>	18.8	16.5	56.2
25		17,900	kg	24 hr. T <sub>1</sub>	0.238	0.384	0.703
				T <sub>2</sub>	19.9	24.9	71.6
				1 wk. T <sub>1</sub>	0.197	0.470	0.725
30				T <sub>2</sub>	25.3	37.1	74.6

	<u>Complex</u>	<u>Coating</u>	<u>Dose</u>	<u>Time After</u> <u>Dose</u>	<u>Relaxation Times</u> (msec.)			
					<u>Liver</u>	<u>Spleen</u>	<u>Lung</u>	
5				2 wk.	T <sub>1</sub>	0.258	0.525	0.731
					T <sub>2</sub>	28.9	44.8	73.3
	AMI-17	Dex-	33.1	4 hr.	T <sub>1</sub>	0.244	0.318	0.674
		tran	$\mu$ moles/		T <sub>2</sub>	16.0	17.4	54.4
10		35,600	kg	24 hr.	T <sub>1</sub>	0.247	0.388	0.690
					T <sub>2</sub>	20.2	22.9	76.4
				1 wk.	T <sub>1</sub>	0.214	0.500	0.696
15					T <sub>2</sub>	24.3	44.0	76.0
				2 wk.	T <sub>1</sub>	0.244	0.562	0.726
					T <sub>2</sub>	28.6	48.6	70.6
20	AMI-18	Dex-	39.2	4 hr.	T <sub>1</sub>	0.228	0.237	0.526
		tran	$\mu$ moles/		T <sub>2</sub>	20.0	17.7	58.6
		249,000	kg	24 hr.	T <sub>1</sub>	0.238	0.354	0.654
					T <sub>2</sub>	21.0	22.0	68.2
25				1 wk.	T <sub>1</sub>	0.235	0.492	0.645
					T <sub>2</sub>	31.4	36.1	71.3
				2 wk.	T <sub>1</sub>	0.240	0.52	0.748
30					T <sub>2</sub>	31.0	39.8	71.3

As before, the data suggest that the contrast agents are rapidly cleared from the lung, and are longer lived in the spleen and the liver. Additionally, it can be seen that the dextran-coated particles are cleared less rapidly than the  
5 uncoated ones, exerting a significant effect on the  $T_2$  values of the liver and spleen for about one week.

## 7.9. PREPARATION OF SUPERPARAMAGNETIC FLUIDS CONTAINING UNCOATED METAL OXIDE

10

### 7.9.1 PREPARATION OF SUPERPARAMAGNETIC IRON OXIDE

A solution of 0.25 M ferrous chloride and 0.5M ferric chloride (600 ml) was poured into a solution of 5 M NaOH (600 ml). A black magnetic oxide precipitate was formed.  
15 This precipitate was washed repeatedly by base and decanted until a pH of about 9 was achieved.

### 7.9.2 DISPERSION AND OXIDATION

20

In a beaker, 400 ml of magnetic oxide (about 15 grams) from Section 7.9.1 and 25 ml of glacial acetic acid were mixed. A sonic probe was placed in the beaker and the solution was sonicated at high intensity for 2 minutes. The  
25 sonic probe was then removed and the solution centrifuged at 1,000 X g for 20 minutes. The pellet was discarded and the supernatant liquid was retained.

30

35

### 7.9.3 TRANSFER TO CITRATE BUFFER

The supernatant, from Section 7.9.2, was dialyzed against ammonium citrate buffer by use of a hollow fiber dialyzer/concentrator, model DC 2 (AMICON Corp. Danvers, MA).  
5 The ammonium citrate buffer is 10 mM citrate, adjusted to pH 8.2 with  $\text{NH}_4\text{OH}$ . The result is an autoclavable, homogeneous supermagnetic fluid.

10

### 7.10. PREPARATION OF AN AQUEOUS, STABLE SUPERPARAMAGNETIC FLUID CONTAINING METAL OXIDE WITH DEXTRAN ATTACHED

15

#### 7.10.1 SYNTHESIS OF IRON OXIDE

Five liters of a solution containing 755 g  $\text{FeCl}_3 \cdot 6\text{H}_2\text{O}$  and 320 g  $\text{FeCl}_2 \cdot 4\text{H}_2\text{O}$  was added slowly to 5 liters of 16%  $\text{NH}_4\text{OH}$  containing 2500 gm dextran (MW=10-15,000).  
20 The iron salt solution was added over 5 minutes during which time the base was vigorously stirred during addition.

A black magnetic slurry was formed.

25

#### 7.10.2. DISPERSION, OXIDATION AND HEATING

The 10 liters of slurry (from Section 7.10.1) was pumped through a continuous flow sonicator connected to a 100°C heating coil and cooling coil apparatus as indicated in  
30 FIG. 6. The pumping rate was about 0.4 liters per minute and pumping was continued for about 30 minutes. The resultant solution was subsequently centrifuged and the precipitated pellet was discarded.

35

### 7.10.3. REMOVAL OF UNREACTED DEXTRAN, TRANSFER TO CITRATE BUFFER AND STERILIZATION

5 The supernatant (from Section 7.10.3) was diluted to a total volume of 20 liters with deionized, sterile water and the resultant solution was dialyzed as in Example 7.9, except that a larger dialyzer concentrator, the DC 10, was used. The dialyzer cartridge had a 100,000 dalton molecular weight cutoff, permitting removal of dextran. Ultrafiltration was  
10 accomplished in a noncontinuous fashion, reducing the volume from 20 to 5 liters and adding 16 liter volumes of solution. Five volumes of 16 liters of deionized, distilled water were added.

15 Sodium citrate was then added as 1M citrate buffer stock and the solution was dialyzed as in Example 7.9. The resultant citrate was adjusted to pH 6.5 with NaOH before autoclaving. The citrate to iron ratio was between 0.01 and 0.1 citrate/Fe in the final solution. (For example, for an  
20 iron concentration of 1.26M, 0.04 M citrate was present. The magnetic fluid was bottled and autoclaved (121°C, 30 minutes). The result is a sterile homogenous magnetic fluid as shown in FIG. 5.

### 25 7.11. PREPARATION OF AN AQUEOUS STABLE SUPERPARAMAGNETIC FLUID CONTAINING METAL OXIDE WITH SILANE ATTACHED

#### 7.11.1. PREPARATION OF IRON OXIDE

30 A solution of 0.25 M ferrous chloride and 0.5M ferric chloride (600 ml) was poured into a solution of 5 M NaOH (600 ml). A black magnetic oxide precipitate formed which was repeatedly washed by base and decanted until a pH of about 9 was achieved.

35

### 7.11.2. DISPERSION, OXIDATION AND SILANIZATION

In a beaker 400 ml of magnetic oxide (from Section 7.11.1., about 15 grams) and 25 ml of glacial acetic acid were mixed. A sonic probe was placed in the beaker and the solution was sonicated at high intensity for 2 minutes. The sonic probe was then removed and 30 ml of N-2-aminoethyl-3-amino-propyltrimethoxysilane was added. The resultant mixture was then sonicated as before. The magnetic solution was subsequently added to 200 ml of glycerol at 50°C. The temperature was raised to 105°C and the water was evaporated.

Due to the use of sonication, the material made in Example 3 is far smaller than that described in United States Patent No. 4,554,088. Due to its small size, it cannot be manipulated with hand held magnets. The glycerol dehydration step is from US Patent 4,554,088 herein incorporated by reference..

### 20 7.11.3. REMOVAL OF UNREACTED SILANE AND TRANSFER TO CITRATE BUFFER

The glycerol slurry, from Section 7.11.2, was added to about 800 ml of water. Large aggregates of magnetic particles were removed by centrifuging the slurry at 1,000 X g for 20 minutes. The supernatant was then dialyzed against citrate buffer in a hollow fiber dialysis device as in Example 6.9.



### 7.12. EFFECT OF THE SUPERPARAMAGNETIC FLUID ON PROTON RELAXATION TIME

The effects of materials on an in vivo MR image can  
5 be evaluated through the use of a magnetic resonance  
spectrometer. In this study, an IBM-PC 20 instrument which  
measures  $T_1$  and  $T_2$  at 25°C, 0.47 Tesla and 20 MHz was used.  
Enhancement of proton relaxation can be quantified by taking  
10 the slope of a plot of  $1/T$ , the reciprocal of the relaxation  
time, versus the concentration of contrast agent. The plot is  
generally linear, with the slope being termed the relaxivity  
and denoted  $R_1$  or  $R_2$ . Relaxivity has units of  $M^{-1} \text{ sec}^{-1}$ .  
Higher relaxivity values indicate that material is more potent  
per mole of iron at decreasing relaxation times of protons  
15 and, thus, is a more potent contrast agent. Relaxivities for  
a number of different forms of magnetic materials were  
determined. The following materials were examined:

Superparamagnetic fluid of the invention: A  
20 dispersed fluid containing single superparamagnetic crystals  
of iron oxide prepared as described in Example 7.10. The  
magnetization curve of this material is presented in FIG. 4.

$\text{Fe}_2\text{O}_3$ : A ferromagnetic gamma ferric oxide used for  
25 data recording. This material was obtained from Pfizer Corp.,  
Minerals, Pigments and Metals Division, catalogue #2228.

Cluster: A silanized cluster of superparamagnetic  
iron oxide with tens to hundreds of crystals packed into  
30 micron-sized particles. This material was made according to  
U.S. Patent No. 4,554,088.

FeO:OH: a paramagnetic, ferric oxyhydroxide used in the treatment of anemia. It was obtained from Fisons Corporation and is sold under the trade names of Proferdex (Fisons corporation) or Imferon (Merrill Dow Inc.)

5

Fe<sup>3+</sup>/DTPA: a soluble complex of ferric ion and diethylenetriaminepentaacetic acid (DTPA). (The data for this material is from Lauffer et al, J. Comp. Assist. Tomog. 9(3), 431 (1985)).

10

The results were as follows:

TABLE III

15 EFFECT OF DIFFERENT FORMS OF IRON ON PROTON RELAXATION TIME

<u>Material</u>	<u>R1</u> (M <sup>-1</sup> X sec <sup>-1</sup> )	<u>R2</u> (M <sup>-1</sup> X sec <sup>-1</sup> )
20 superparamagnetic fluid	4 X 10 <sup>+4</sup>	1.6X10 <sup>+5</sup>
gamma Fe <sub>2</sub> O <sub>3</sub>	100	7.2 X 10 <sup>+3</sup>
25 FeO:OH	0	60
Cluster	2 X 10 <sup>+3</sup>	3 X 10 <sup>+4</sup>
Fe <sup>3+</sup> /DTPA	0.73 X 10 <sup>+3</sup>	0.85 X 10 <sup>+4</sup>

30

Briefly, as the high values of R1 and R2 indicate, the material of the invention is remarkable in its ability to shorten proton relaxation times. For comparison, the value of

35

R2 for ferromagnetic dextran magnetite is  $1.7 \times 10^{+4} \text{ M}^{-1} \text{ sec}^{-1}$  [Ohgushi et al., J. Mag Res. 29, 599 (1978)]. This is the highest literature value for R2 of which the authors are aware. The materials prepared according to the invention are  
5 more potent enhancers of proton relaxation time than either ferromagnetic materials or paramagnetic ferric oxyhydroxides.

Additionally, well dispersed materials, such as those of the invention, have higher relaxivities than  
10 clustered materials. Thus, the process of the invention yields superparamagnetic solutions optimized for their effects on proton relaxation.

#### 15 7.13. BULK MAGNETIC PROPERTIES OF SUPERPARAMAGNETIC FLUIDS

Magnetic hysteresis loops were obtained for the samples of the invention superparamagnetic fluid, gamma  $\text{Fe}_2\text{O}_3$  (ferromagnetic), and  $\text{FeO}:\text{OH}$  (paramagnetic) examined in Example  
20 7.12, using a commercial vibrating sample magnetometer with fields up to 6000 Gauss, 25°C. The results are presented in FIG. 4.

Briefly, at high magnetic fields, the  
25 superparamagnetic fluid of the invention is nearly as magnetic as ferromagnetic iron oxide and far more magnetic than the paramagnetic ferric oxyhydroxide, showing a high magnetic saturation. The fluids of the invention are superparamagnetic rather than ferromagnetic, losing virtually all of their  
30 magnetic moment in the absence of an applied magnetic field.

#### 7.14. RETENTION OF CITRATE

The retention of  $^{14}\text{C}$  citrate upon dialysis can be  
35 used to distinguish various forms of iron oxide as shown in Table IV. All iron oxides were initially dialyzed against a

buffer of 1 mM Tris-Cl, pH 8 before use. Equilibrium dialysis was then performed to determine fraction of citrate retained. The concentrations of iron and citrate were 17.8 and 2.6 mM, respectively. The superparamagnetic fluids of the invention  
5 retain amounts of citrate similar to commercially available ferric oxyhydroxides indicating that the iron in both preparations is in a similar chemical form. Commercially available forms of iron oxide, such as gamma  $\text{Fe}_2\text{O}_3$  or  $\text{Fe}_3\text{O}_4$ , do not retain significant amounts of citrate (the gamma  $\text{Fe}_2\text{O}_3$   
10 was the same as that used in Examples 7.12 and 7.13 while the  $\text{Fe}_3\text{O}_4$  was purchased from Fisher Scientific Inc). The inability of these commercially available iron oxides to retain citrate, coupled with the ability of ferric oxyhydroxide to do so, strongly suggests that citrate does not  
15 absorb to iron oxide surfaces through the usual chemical adsorption mechanism. The retention of citrate by the superparamagnetic iron oxides of the invention indicates these materials have an ionic character similar to the ferric oxyhydroxides.

20

25

30

35

TABLE IVRETENTION OF CITRATE BY SOLUTIONS WITH DIFFERENT IRON OXIDES

5

<u>Material</u>	<u>Citrate Retained per Iron</u> (mole/mole)
FeO:OH	0.026
10 Invention	0.019
gamma Fe <sub>2</sub> O <sub>3</sub>	0.0028
Fe <sub>3</sub> O <sub>4</sub>	0.0018

---

15

7.15. STABILITY OF SUPERPARAMAGNETIC FLUIDS

Superparamagnetic fluids made according to example  
20 7.9 were subjected to autoclaving with various concentrations  
of citrate. At iron concentration of 1.26M, various  
concentrations of ammonium citrate, pH8 were added, and the  
resulting solutions heated 1 hour at 121°C. The results are  
presented in FIG. 5. The 6 vials of Fig. 5B contained, as  
25 shown, citrate concentrations of 100, 50, 25, 15, 10 and 5 mM  
citrate, respectively. The vials were upright during  
autoclaving but were placed horizontally for the photograph.  
With the vials lying horizontally, the presence of gelled  
material is evident when the upper portion of the vial is  
30 translucent. The fully blackened vials (citrate  
concentrations between 15 and 100 mM) indicate a solution of  
superparamagnetic materials was maintained. The two vials on  
the right (citrate concentration of 5 and 10mM) show the

35

formation of a gel. FIG. 5A further shows the characteristic gel obtained without citrate, or with inadequate citrate (5 and 10 mM citrate).

5

#### 7.16. BIODEGRADABILITY OF SUPERPARAMAGNETIC FLUIDS

Paramagnetic ferric oxyhydroxides are biodegradable and have long been used for the treatment of anemia. Therefore, the biodegradability of the invention's  
10 superparamagnetic fluids was compared with the paramagnetic ferric oxyhydroxides. The ability of both iron preparations to reverse anemia in rats was utilized as a model. The paramagnetic ferric oxyhydroxide was Imferon, and has dextran  
15 attached. The supermagnetic fluid also had dextran attached and was produced as described in Example 7.10.

Weanling rats were divided into four groups of five rats each. Rats in group 1 received a chow containing iron and were sacrificed at weeks 5, 6, 7 and 8 to allow  
20 establishment of normal iron (hematocrit) levels in rat tissues. Rats in groups 2, 3 and 4 received an iron deficient diet. Rats in group 2 were also sacrificed at weeks 5, 6, 7, and 8 to allow establishment of normal iron levels in rat  
25 tissues. Rats in groups 2, 3 and 4 received an iron deficient diet. After receiving the low iron diet for 5 weeks, rats in groups 3 and 4 received intravenous (tail vein) injections of iron to reverse their anemia and restore normal levels. Rats in group 3 received Proferdex, while those in group 4 received the dextranized superparamagnetic fluid. Rats receiving iron  
30 were injected with a single dose of 30 mg of iron per kilogram, a sufficient dose to reverse their anemia. The results are presented in Table V.

35

TABLE VREVERSAL OF ANEMIA WITH SUPERPARAMAGNETIC IRON OXIDE PARTICLES

	<u>Hematocrit (1% red cells in whole blood)</u>							
	week 5		week 6		week 7		week 8	
	avg	sd	avg	sd	avg	sd	avg	sd
chow	45.1	1.4	45.2	0.5	46.7	0.9	47.0	0.8
low Fe	28.5	2.6	29.5	2.1	32.7	1.2	34.8	2.3
Imferon			43.1	1.9	42.8	1.3	46.3	1.2
Invention			44.3	2.3	42.7	1.1	47.6	1.6

It can be seen that the invention's superparamagnetic iron oxide restores normal hematocrits levels in rats as well as the paramagnetic preparation, Imferon.

7.17. SUMMARY OF SUPERPARAMAGNETIC FLUID PROPERTIES

The properties of the superparamagnetic fluids of the invention compared with solutions made with other types of ferric oxide are summarized TABLE VI:

25

30

35

TABLE VISUMMARY OF PROPERTIES OF AQUEOUS SOLUTIONS OF VARIOUS FERRIC OXIDES

5

	<u>Mag. Saturation</u> (FIG. 4)	<u>MR Relaxivity</u> (Table II)	<u>Biodegradability</u> (Table V)	<u>Citrate retention</u> (Table IV)
FeO:OH	low	none	high	high
10 gamma Fe <sub>2</sub> O <sub>3</sub>	high	some		low
Invention	high	high	high	high

15 Thus, the superparamagnetic fluids of this invention possess a unique combination of magnetic, biological and anion retaining properties.

7.18. EXTENSION OF THE SERUM LIFETIME OF DEXTRAN COATED SUPERPARAMAGNETIC IRON OXIDE PARTICLES

20 To assess the effectiveness of dextran-coated paramagnetic iron oxide as a serum lifetime extender for dextran-coated superparamagnetic iron oxide particles, a comparative study was conducted.

25 In both trials, a rat of about 300 g was injected with 1 mg Fe/kg body weight of dextran-coated superparamagnetic metal oxide produced as described in Example 7.1. However, in one trial, the rat was also injected with 2.5 mg Fe/kg dextran-coated paramagnetic iron oxide (produced following the procedure described in example 7.1 except that 30 no divalent salt was used) 15 minutes prior to receiving the superparamagnetic material. The T<sub>2</sub> of the subject's blood was measured periodically over the subsequent 3 hours. The results are present in Figure 7.



Briefly, in both trials, the blood  $T_2$  dropped dramatically within 5 minutes after the superparamagnetic material was added. However, the value rapidly returned to normal in the rat which did not receive the superparamagnetic material, presumably due to absorption of the agent by the reliculoendothelial system (RES). In contrast, when the paramagnetic agent was used the  $T_2$  depression is dramatically extended. This is due to a competition between the superparamagnetic and the paramagnetic material for RES receptors, greatly expanding the lifetime of the superparamagnetic agent.

It is apparent that many modifications and variations of this invention as hereinabove set forth may be made without departing from the spirit and scope thereof. The specific embodiments described are given by way of example only and the invention is limited only by the terms of the appended claims.

20

25

30

35

## WHAT IS CLAIMED IS:

1. An improved method for obtaining an in vivo MR image of an organ or tissue of an animal or human subject, wherein the improvement comprises administering to such a subject as a contrast agent to enhance such MR image an effective amount of a dispersoid which comprises uncoated biodegradable superparamagnetic metal oxide particles dispersed in a physiologically acceptable carrier, an individual particle (i) comprising metal oxide crystals of about 50 to about 500 angstroms in diameter; (ii) having an overall mean diameter of about 50 angstroms to about 5000 angstroms as measured by light scattering; and (iii) further characterized as having a retention time in said organ or tissue sufficiently long to permit an image to be obtained and being biodegradable.

2. An improved method for obtaining an in vivo MR image of an organ or tissue of an animal or human subject, wherein the improvement comprises administering to such a subject as a contrast agent to enhance such MR image an effective amount of a dispersoid which comprises coated biodegradable superparamagnetic metal oxide particles dispersed in a physiologically acceptable carrier, said particles consisting of superparamagnetic metal oxide cores, each core generally surrounded by a polymeric coat, an individual particle (i) comprising metal oxide crystals of about 50 to about 500 angstroms in diameter; (ii) having an overall mean diameter of about 50 angstroms to about 5000 angstroms as measured by light scattering; and (iii) further characterized as having a retention time in said organ or tissue sufficiently long to permit an image to be obtained and being biodegradable.

3. The method of claim 1 or 2 wherein the superparamagnetic metal oxide particle is an iron oxide particle (i) comprising crystals of about 50 to about 500 angstroms in diameter; (ii) having a surface area greater than  
5 about  $75\text{m}^2/\text{gram}$ ; (iii) having a magnetic saturation between about 5 and about 90 EMU/gram of iron oxide; and (iv) possessing a magnetic squareness of less than 0.1.

4. The method of claim 2 wherein the polymeric  
10 coat is selected from the group consisting of carbohydrates, proteins, and composites thereof.

5. The method of claim 2 wherein the polymeric coat consists of albumin.  
15

6. The method of claim 5 wherein the albumin is selected from the group consisting of human serum albumin and bovine serum albumin.

7. The method of claim 2 wherein the polymeric  
20 coat consists of dextran having a molecular weight between 5,000 and 250,000 daltons.

8. The method of claim 7 wherein the dextran is  
25 selected from the group consisting of dextran of 9,000 MW, dextran of 17,900 MW, dextran of 35,600 MW, dextran of 71,000 MW and dextran of 249,000 MW.

9. The method of claim 1 or 2 wherein said  
30 dispersoid is administered to the subject by intravascular injection.

10. The method of claim 1 or 2 wherein said dispersoid is administered to the subject by a method selected from the group consisting of oral administration, intubation, and by enema.

5

11. The method of claim 9 wherein the physiologically acceptable carrier is selected from the group consisting of normal saline and distilled water.

10

12. The method of claim 10 wherein said physiologically acceptable carrier is distilled water.

15

13. The method of claim 1 or 2 wherein the superparamagnetic metal oxide particles are administered at a dosage of up to about 250 mg per Kilogram of body weight of the subject.

20

14. The method of claim 1 or 2 wherein the organ or tissue imaged is part of the reticuloendothelial system.

15. The method of claim 14 wherein the organ imaged is a liver.

25

16. The method of claim 14 wherein the organ imaged is a spleen.

17. The method of claim 14 wherein the tissue imaged is bone marrow.

30

18. The method of claim 14 wherein the organ or tissue imaged is lymph or lymph nodes.

19. The method of claim 1 or 2 wherein the tissue imaged is neural tissue.

35

20. The method of claim 1 or 2 wherein the organ imaged is a lung.

5 21. The method of claim 1 or 2 wherein the organ or tissue imaged is part of the gastrointestinal tract.

22. The method of claim 21 wherein the organ imaged is an esophagus.

10 23. The method of claim 21 wherein the organ imaged is a stomach.

24. The method of claim 21 wherein the organ imaged is a small intestine.

15

25. The method of claim 21 wherein the organ imaged is a large intestine.

20 26. An improved method for obtaining an in vivo MR <sup>o</sup> image of an organ or tissue of an animal or human subject, wherein the improvement comprises administering to such a subject as a contrast agent to enhance such MR image an effective amount of a superparamagnetic fluid comprising superparamagnetic metal oxides in aqueous solution, said metal  
25 oxides (i) having a magnetic saturation between about 5 and about 90 EMU/gm of metal oxide at approximately 300°K and a magnetic squareness of less than 0.1, characteristic of a superparamagnetic metal oxide crystal; (ii) being capable of retaining anions, in solution in a manner characteristic of  
30 paramagnetic metal oxides; (iii) having an overall mean diameter of about 50 to about 4000 angstroms as measured by light scattering; and (iv) further characterized as having a retention time in said organ or tissue sufficiently long to permit an image to be obtained and being biodegradable.

35

27. An improved method for obtaining an in vivo MR image of an organ or tissue of an animal or human subject, wherein the improvement comprises administering to such a subject as a contrast agent to enhance such MR image an effective amount of a superparamagnetic fluid comprising small superparamagnetic metal oxides attached to a polymeric coating in aqueous solution, said metal oxides (i) having a magnetic saturation between about 5 and about 90 EMU/gm of metal oxide at approximately 300°K and a magnetic squareness of less than 0.1 characteristic of super paramagnetic metal oxide crystals; (ii) being capable of retaining anions in solution in a manner characteristic of paramagnetic metal oxides; (iii) having an overall mean diameter of about 50 to about 4000 angstroms as measured by light scattering; and (iv) further characterized as having a retention time in said organ or tissue sufficiently long to permit an image to be obtained and being biodegradable.

28. The method of claims 26 or 27 wherein the superparamagnetic fluid comprises a superparamagnetic iron oxide in an aqueous polycarboxylic acid buffer further characterized by:

(i) an iron concentration ranging from 0.05 to 5 molar;

(ii) a polycarboxylate counterion concentration ranging from 0.001 to 0.1 moles of tricarboxylate per mole of iron; and

(iii) a pH between about 6 and about 8.3 wherein the fluid is characterized by a saturation magnetization of between about 30 and about 90 EMU/g of iron oxide and a magnetic squareness of less than 0.1.

29. The method of claim 28 wherein the aqueous polycarboxylic acid buffer is selected from the group consisting of aqueous citrate buffer, aqueous tartrate buffer, aqueous succinate buffer, and aqueous maleate buffer.

5

30. The method of claim 28 wherein the iron concentration is about 1.26 molar, the citrate concentration is about 0.04 molar, and the pH is about 6.5.

10

31. The method of claim 27 wherein the polymeric coating is selected from the group consisting of carbohydrates, polypeptides, organosilanes, proteins, and composites thereof.

15

32. The method of claim 27 wherein the polymeric coating consists of dextran having a molecular weight between 5,000 and 250,000 daltons.

20

33. The method of claim 27 wherein the protein is BSA.

34. The method of claim 27 wherein the polymeric coating is N-2-aminoethyl-3-aminopropyltrimethoxysilane.

5

35. The method of claim 26 or 27 wherein said superparamagnetic fluid is administered to the subject by intravascular injection.

30

36. The method of claim 26 or 27 wherein said superparamagnetic fluid is administered to the subject by a method selected from the group consisting of oral administration, intubation, and by enema.

35

37. The method of claim 26 or 27 wherein the organ or tissue imaged is part of the reticuloendothelial system.

5 38. The method of claim 37 wherein the organ imaged is a liver.

39. The method of claim 37 wherein the organ imaged is a spleen.

10 40. The method of claim 37 wherein the tissue imaged is bone marrow.

15 41. The method of claim 37 wherein the organ or tissue imaged is lymph or lymph nodes.

42. The method of claim 26 or 27 wherein the tissue imaged is neural tissue.

20 43. The method of claim 26 or 27 wherein the organ imaged is a lung.

44. The method of claim 26 or 27 wherein the organ or tissue imaged is part of the gastrointestinal tract.

25 45. The method of claim 44 wherein the organ imaged is an esophagus.

30 46. The method of claim 44 wherein the organ imaged is a stomach.

47. The method of claim 44 wherein the organ imaged is a small intestine.



48. The method of claim 44 wherein the organ imaged is a large intestine.

49. The method of claim 2 or 27 in which the  
5 magnetic metal oxides further comprise an effective amount of  
biological molecules covalently coupled to said coating, said  
biological molecules possessing functional groups which are  
recognized by receptors in various organs and tissues of the  
subject, such that the particles are directed in vivo to the  
10 organ or tissue which recognizes the attached biological  
molecule.

50. The method of claim 49 wherein the biological  
molecule is an antibody.

15

51. The method of claim 50 wherein the antibody is  
an anti-melanoma antibody and the tissue being imaged is  
melanoma tissue.

20

52. The method of claim 50 wherein the antibody is  
an anti-heart myosin antibody and the tissue being imaged is  
infarcted heart tissue.

53. The method of claim 50 wherein the antibody is  
5 an anti-T-cell antibody and the tissue being imaged is  
lymphoma tissue.

54. The method of claim 50 wherein the antibody is  
anti-carcinomic embryonic antigens and the tissue being imaged  
is colonic tumor tissue.

30

55. The method of claim 50 wherein the antibody is  
an anti-ovarian cancer cell antibody and the tissue being  
imaged is ovarian cancer tissue.

35

56. The method of claim 49 wherein the biological molecule is a carbohydrate.

57. The method of claim 49 wherein the biological molecule is a hormone.

58. An autoclavable superparamagnetic fluid comprising a superparamagnetic iron oxide in an aqueous tricarboxylic acid buffer, further characterized by:

(i) an iron concentration ranging from 0.05 to 5 molar;

(ii) a polycarboxylate counterion concentration ranging from 0.001 to 0.1 moles of tricarboxylate per mole of iron; and

(iii) a pH between about 6 and about 9 wherein the fluid is characterized by a saturation magnetization of between about 30 and about 90 EMU/g of iron oxide at approximately 300°K and a magnetic squareness of less than 0.1.

59. The superparamagnetic fluid of claim 58 wherein the aqueous polycarboxylic acid buffer is selected from the group consisting of aqueous citrate buffer, aqueous tartrate buffer, aqueous succinate buffer, and aqueous maleate buffer.

60. The superparamagnetic fluid of claim 59 wherein the aqueous citrate buffer is selected from the group consisting of sodium citrate buffer, potassium citrate buffer, and ammonium citrate buffer.

61. The superparamagnetic fluid of claim 58 wherein the iron concentration is about 1.26 molar, the citrate concentration is about 0.04 molar, and the pH is about 8.0

62. The superparamagnetic fluid of claim 58 which further comprises a polymeric coating attached to said iron oxide.

5 63. The superparamagnetic fluid of claim 62 wherein the coating is a dextran having a molecular weight between 5 and 250,000 daltons.

64. The superparamagnetic fluid of claim 62 wherein  
10 the coating is a protein having a molecular weight between 5,000 and 250,000 daltons.

65. The superparamagnetic fluid of claim 64 wherein the protein is selected from the group consisting of bovine  
15 serum albumin and human serum albumin.

66. The superparamagnetic fluid of claim 62 wherein the coating is a polypeptide having a molecular weight between 5,000 and 250,000 daltons.

20 67. The superparamagnetic fluid of claim 66 wherein the polypeptide is polyglutamate.

68. The superparamagnetic fluid of claim 60 wherein  
25 the polypeptide is polylysine.

69. The superparamagnetic fluid of claim 63 wherein the coating is a organosilane having a molecular weight between 5,000 and 250,000 daltons.

30 70. The superparamagnetic fluid of claim 69 wherein the organosilane is N-2-aminoethyl-3-aminopropyltrimethoxy-silane.

35

71. A method for preparing stable superparamagnetic fluids comprising:

- (i) forming a superparamagnetic metal oxide by base precipitation of divalent and trivalent iron salts;
- 5 (ii) dispersing and oxidizing said superparamagnetic metal oxide by sonication at a temperature between ambient or 100°C; and
- (iii) transferring the soluble superparamagnetic metal oxide to a tricarboxylic acid buffer by
- 10 dialysis.

72. The method of claim 71 wherein the divalent and trivalent iron salts are present in a ratio ranging from 1:4 to 4:1.

15

73. The method of claim 71 wherein the divalent and trivalent iron salts are  $\text{FeCl}_2$  and  $\text{FeCl}_3$ .

74. The method of claim 71 which further comprises replacing a portion of the divalent iron salt with a divalent salt of cobalt or manganese.

20

75. The method of claim 74 wherein the portion of divalent iron salt replaced is half or less.

76. The method of claim 71 wherein the sonication is accomplished by sonic probe.

77. The method of claim 71 wherein the sonication is accomplished in a continuous flow sonicator.

30

78. The method of claim 71 wherein the tricarboxylic acid buffer is a citrate buffer.

35

79. The method of claim 71 wherein the tricarboxylic acid buffer is a tartrate buffer.

80. A superparamagnetic metal oxyhydroxide  
5 comprising water soluble superparamagnetic metal oxides, said metal oxides (i) having a magnetic saturation between about 5 and about 90 EMU/gm of metal oxide at approximately 300°K and a magnetic squareness of less than 0.1, characteristic of a superparamagnetic metal oxide crystal; (ii) being capable of  
10 retaining anions wherein solution, characteristic of paramagnetic metal oxides in solution; (iii) having an overall mean diameter of about 50 to about 4000 angstroms as measured by light scattering; and (iv) and further characterized by being capable of forming solution in water at concentrations  
15 up to about 5 molar.

81. A superparamagnetic ferric oxyhydroxide comprising small water soluble superparamagnetic ferric oxides, said ferric oxides (i) having a magnetic saturation  
20 between about 5 and about 90 EMU/gm of ferric oxide at approximately 300°K and a magnetic squareness of less than 0.1, characteristic of a superparamagnetic ferric oxide crystal; (ii) being capable of retaining anions solution, characteristic of paramagnetic ferric oxides in solution; (iii) having an overall mean diameter of about 50 to about 4000 angstroms as measured by light scattering; and (iv) and further characterized by being capable of forming solution in water at concentrations up to about 5 molar.

82. A method for extending the serum lifetime of a  
30 superparamagnetic MR contrast agent in an animal or human subject comprising administering to said subject prior to, or simultaneously with, administering said contrast agent, an effective amount of a blocking agent in a physiologically

acceptable carrier, said blocking agent being capable of competitively binding to reticuloendothelial system receptors which can remove the contrast agent from circulation.

5           83. The method of claim 82 wherein the blocking agent is a paramagnetic form of the contrast agent.

          84. The method of claim 82 wherein the contrast agent is a superparamagnetic iron oxide and the blocking agent  
10 is a paramagnetic form of the superparamagnetic iron oxide.

          85. A method for detecting in vivo blood flow in animal or human subject comprising:

15           (i) administering to said subject an effective amount of a dispersoid of a blocking agent in a physiologically acceptable carrier said blocking agent being recognized by RES receptors;

          (ii) subsequently administering to said  
20 subject a dispersoid or solution of a superparamagnetic MR contrast agent in a physiologically-acceptable carrier said NMR contrast-agent competing for the same RES receptors as in (i);

          (iii) obtaining an MR image of the blood in a  
25 section of the subject; and

          (iv) detecting the presence or absence of blood flow in the section.

          86. The method of claim 85 wherein the blocking  
30 agent is a paramagnetic form of the superparamagnetic MR contrast agent.

87. The method of claim 85 wherein the superparamagnetic MR contrast agent is a superparamagnetic iron oxide and the blocking agent is a paramagnetic form of the superparamagnetic iron oxide.

5

88. A method for reducing anemia in an animal or human subject comprising parenterally administering to said subject an effective amount of a dispersoid of the superparamagnetic iron oxides of claim 3.

10

89. A method for reducing anemia in an animal or human subject comprising parenterally administering to said subject an effective amount of the superparamagnetic fluid of claim 56.

15

20

25

30

35

- 1 / 7

FIG. 1

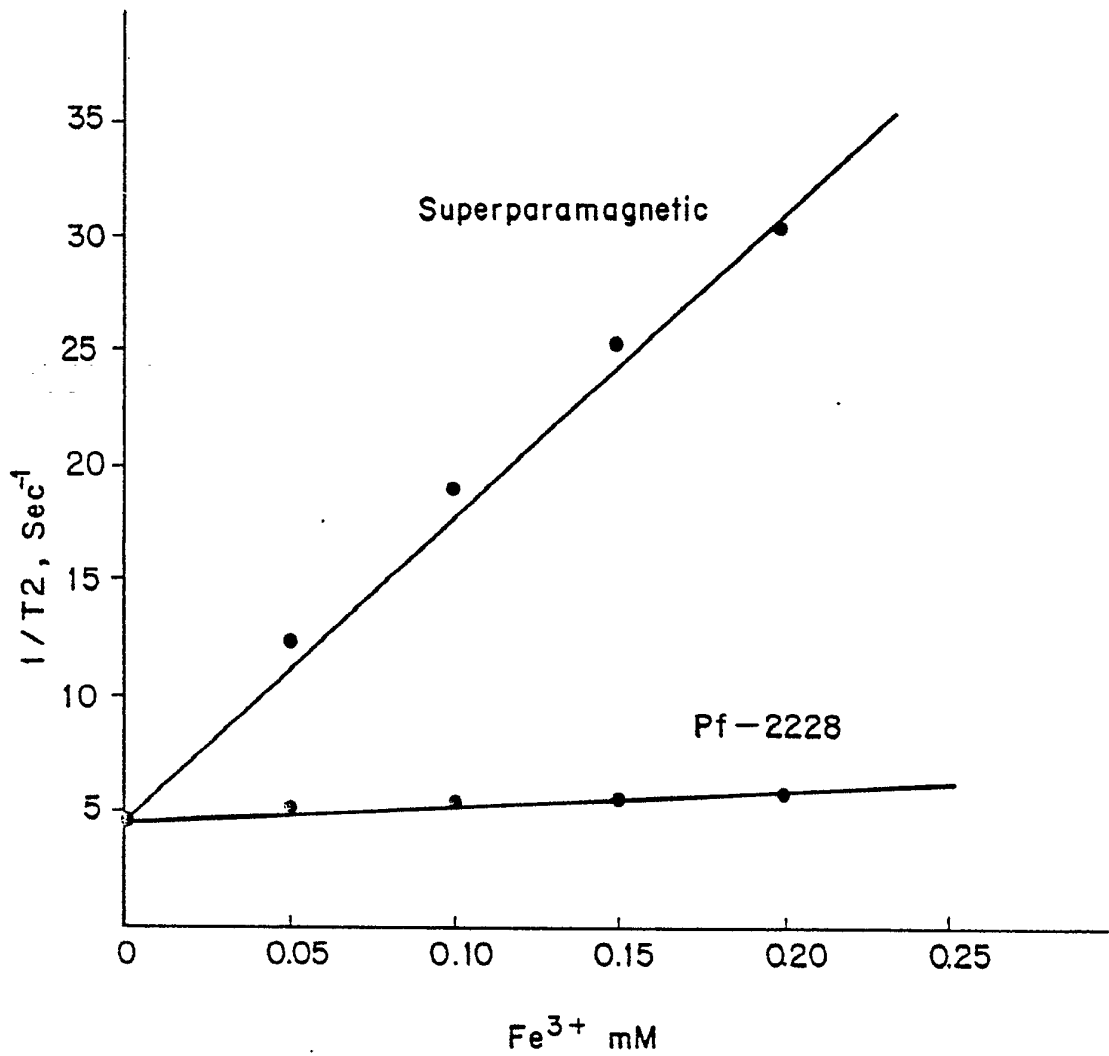





FIG. 2A



FIG. 2B



FIG. 2C



FIG. 2D



FIG. 2E

# FIG. 3

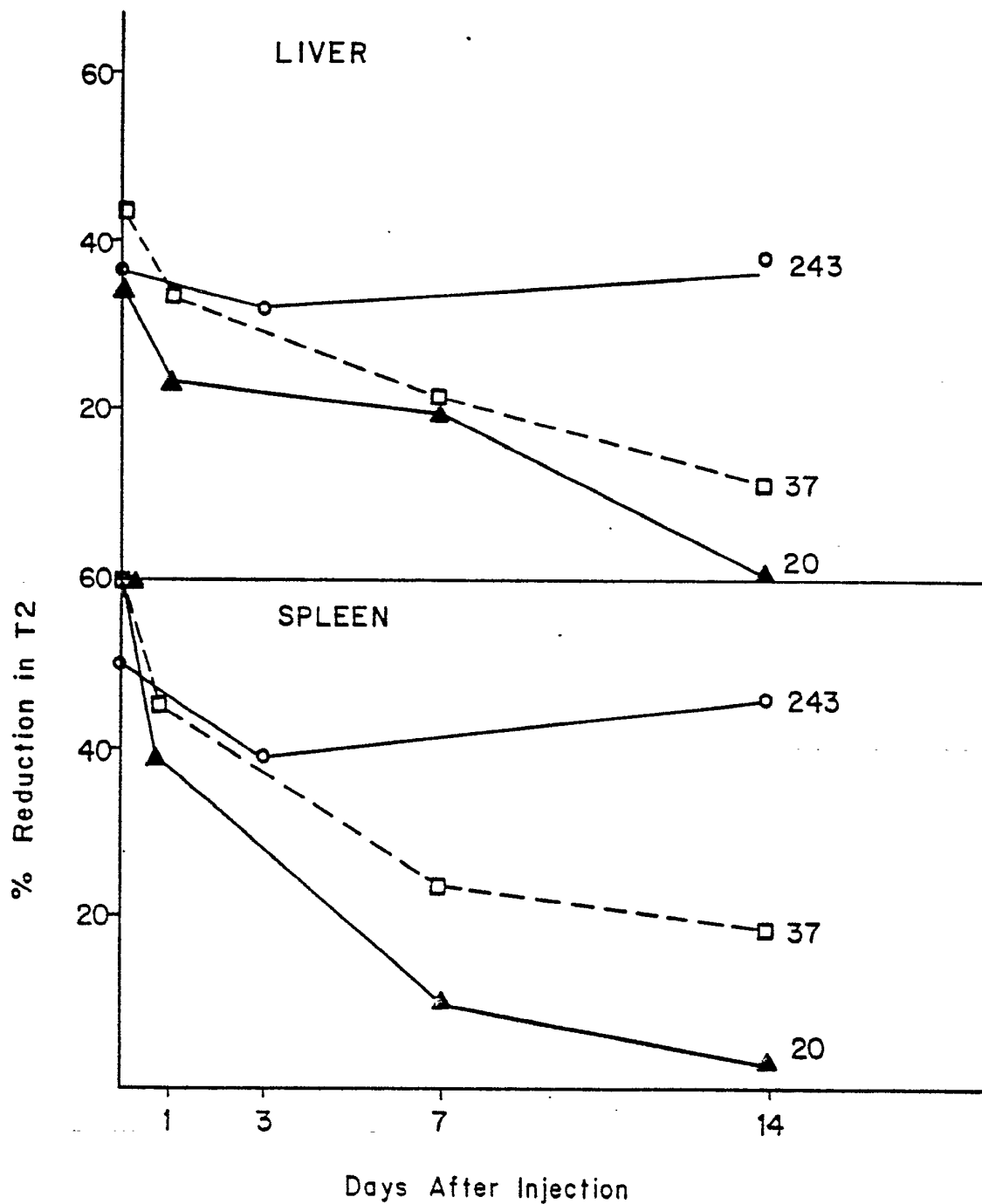
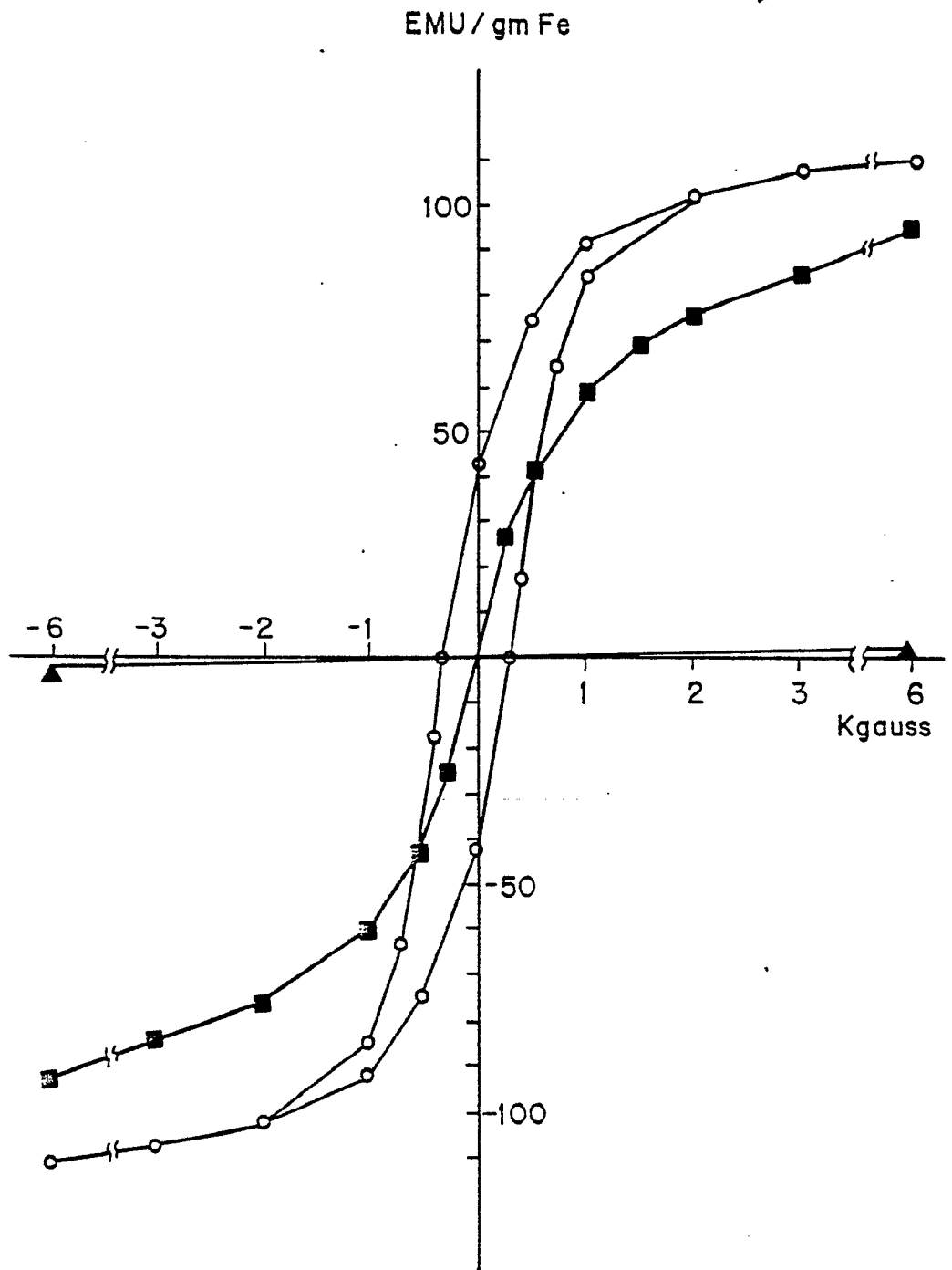

FIG. 4



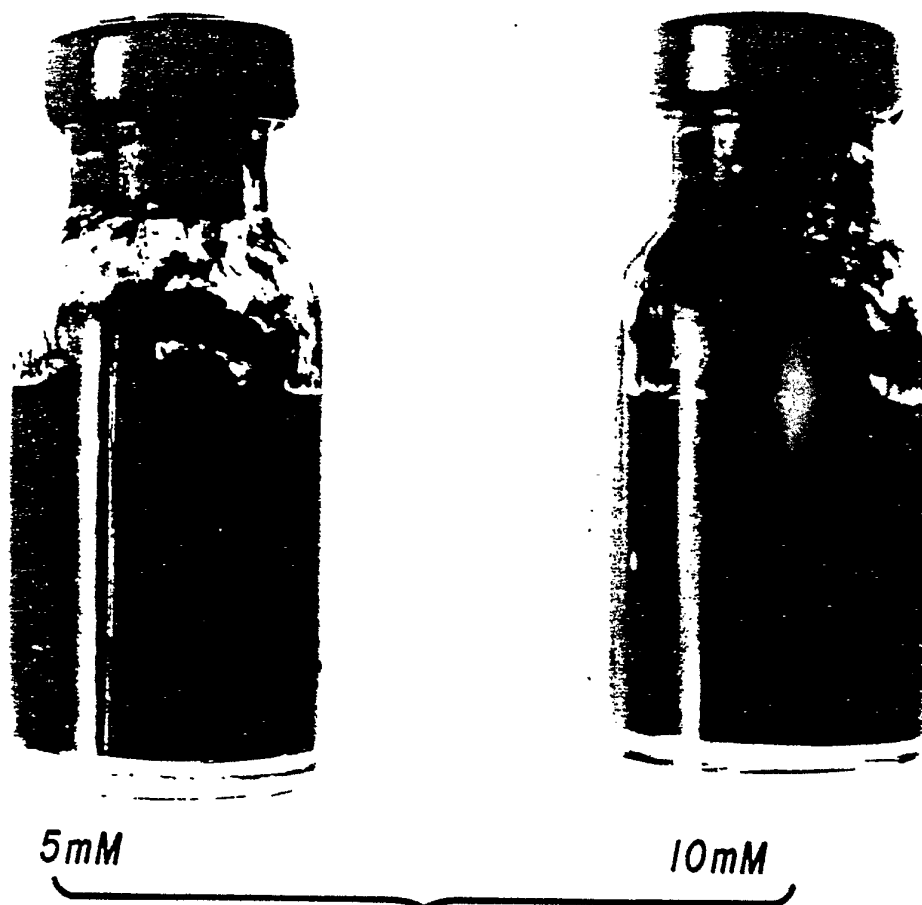

FIG. 5A

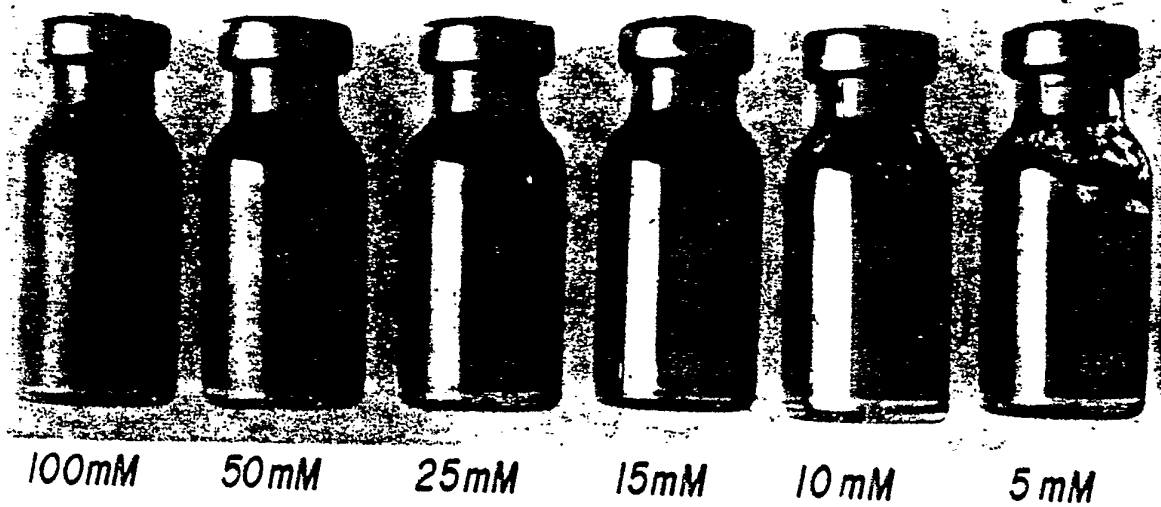
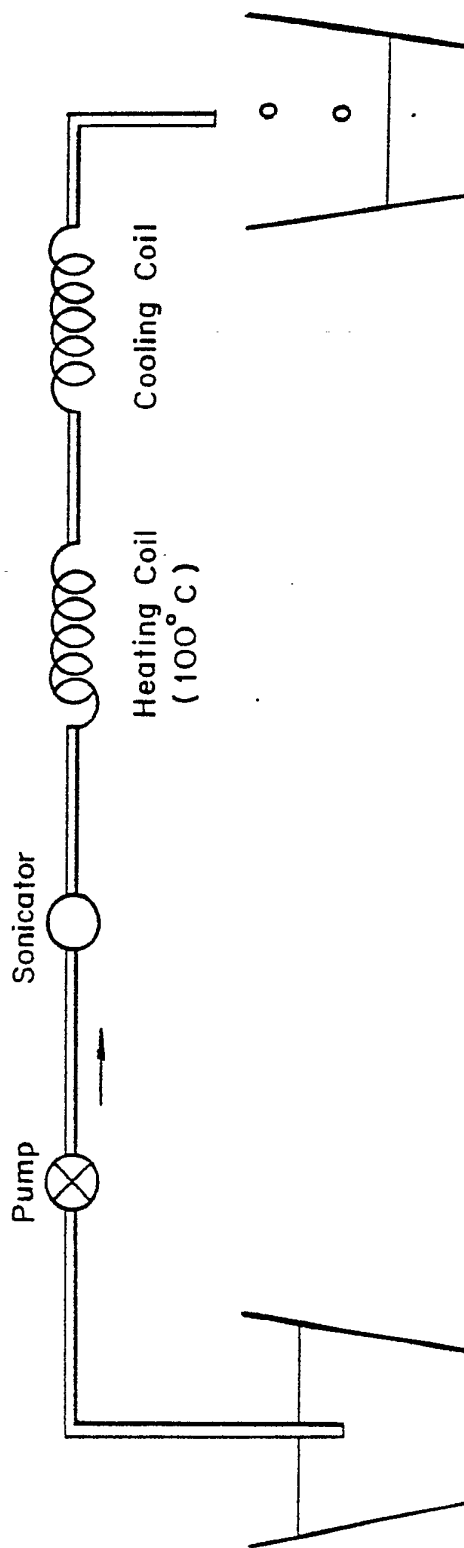

FIG. 5B

FIG. 6

Schematic Diagram of Apparatus For Synthesizing Stable Superparamagnetic Fluids



**FIG. 7** Blood T2 Depression With Blocking Agent

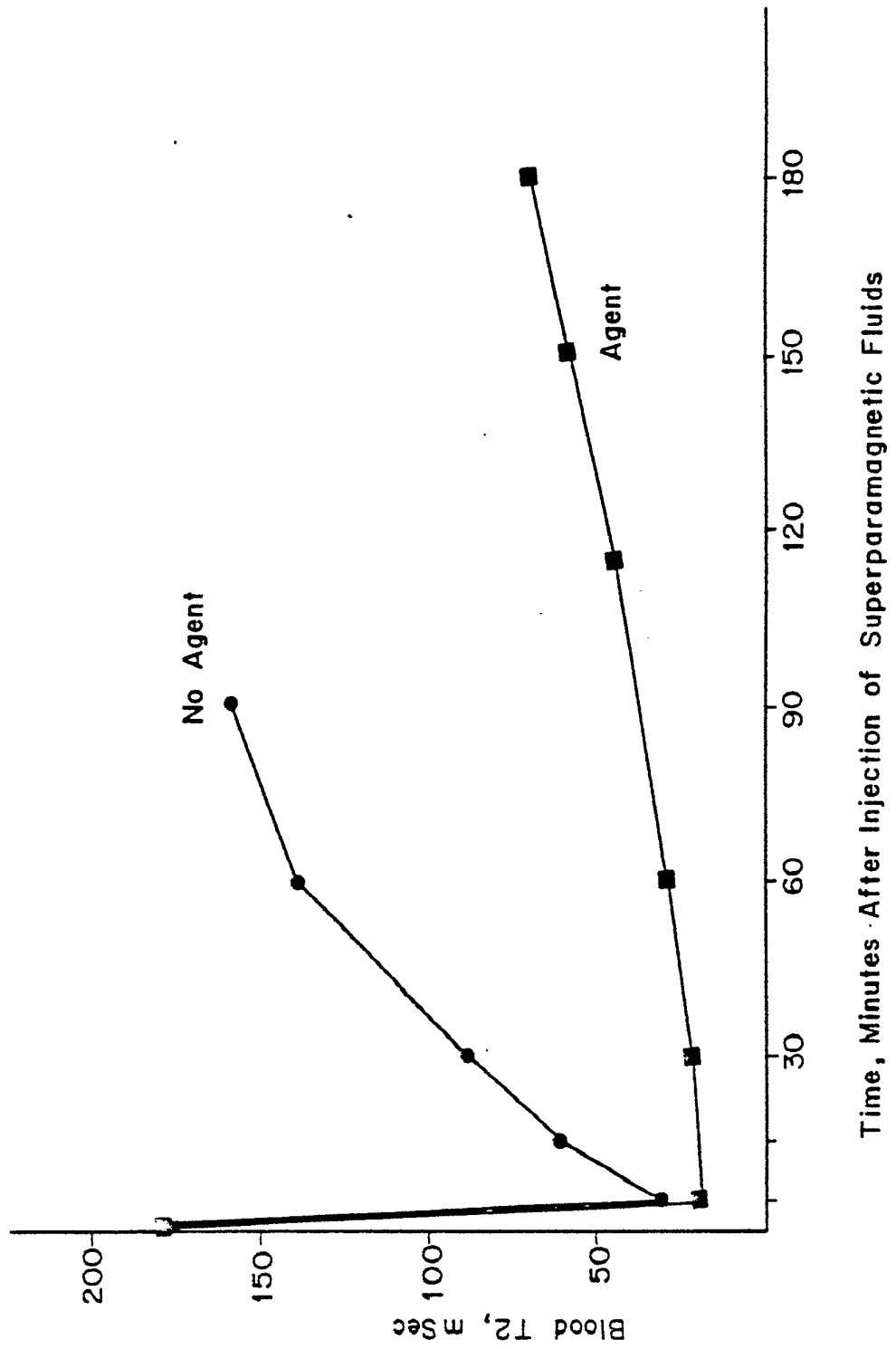

# INTERNATIONAL SEARCH REPORT

International Application No

PCT/US87/01588

<b>I. CLASSIFICATION OF SUBJECT MATTER</b> (if several classification symbols apply, indicate all) <sup>3</sup>		
According to International Patent Classification (IPC) or to both National Classification and IPC		
IPC (4): A61K 49/00		
U.S. Cl. 128/653		
<b>II. FIELDS SEARCHED</b>		
Minimum Documentation Searched <sup>4</sup>		
Classification System	Classification Symbols	
U.S.	128/653, 654, 1.1, 1.3 424/9, 1.1	
Documentation Searched other than Minimum Documentation to the Extent that such Documents are Included in the Fields Searched <sup>6</sup>		
<b>III. DOCUMENTS CONSIDERED TO BE RELEVANT</b> <sup>14</sup>		
Category <sup>5</sup>	Citation of Document, <sup>16</sup> with indication, where appropriate, of the relevant passages <sup>17</sup>	Relevant to Claim No. <sup>18</sup>
Y, P	US, A, 4,656,026 (COFFMAN ET AL.) 07 April 1987, see column 2, lines 25-55, column 4; lines 54-68.	2, 4, 19, 49
X, P	US, A, 4,615,879 (RUNGE ET AL.) 07 October 1986, see the entire document.	1, 10, 9, 21, 22
X, P	US, A, 4,675,173 (WIDDER) 23 June 1987 • See the entire document.	1-7, 9-12, 15, 16, 26, 27, 31, 32, 35-39, 49, 56, 57
$\frac{X}{Y}$	US, A, 4,452,773 (MOLDAY) 05 June 1984 See the entire document.	2-7, 9-11, 26, 27, 31-34, 49-57, 80, 81 <hr/> 8, 14-25, 35-48
<p><sup>5</sup> Special categories of cited documents: <sup>15</sup></p> <p>"A" document defining the general state of the art which is not considered to be of particular relevance</p> <p>"E" earlier document but published on or after the international filing date</p> <p>"L" document which may throw doubts on priority claim(s) or which is cited to establish the publication date of another citation or other special reason (as specified)</p> <p>"O" document referring to an oral disclosure, use, exhibition or other means</p> <p>"P" document published prior to the international filing date but later than the priority date claimed</p> <p>"T" later document published after the international filing date or priority date and not in conflict with the application but cited to understand the principle or theory underlying the invention</p> <p>"X" document of particular relevance: the claimed invention cannot be considered novel or cannot be considered to involve an inventive step</p> <p>"Y" document of particular relevance: the claimed invention cannot be considered to involve an inventive step when the document is combined with one or more other such documents, such combination being obvious to a person skilled in the art.</p> <p>"&amp;" document member of the same patent family</p>		
<b>IV. CERTIFICATION</b>		
Date of the Actual Completion of the International Search <sup>1</sup>		Date of Mailing of this International Search Report <sup>2</sup>
25 September 1987		09 OCT 1987
International Searching Authority <sup>3</sup>		Signature of Authorized Officer <sup>20</sup>
ISA/US		Mark F. Colosimo <i>Mark F. Colosimo</i>

## FURTHER INFORMATION CONTINUED FROM THE SECOND SHEET

<input checked="" type="checkbox"/> X <input type="checkbox"/> Y	WO 85/04330 (NYEGAARD & CO.) 10 October 1985 See the entire document.	1, 2, 4-6, 9-12, 14-17, 21, 23 <hr/> 3, 7, 8, 12, 13, 18-20, 22-27, 31-48
Y,P	US, A, 4,637,929 (QUAY) 20 January 1987 See column 1, lines 30-31, and column 4, lines 22-44.	14-25, 37-48

V.  OBSERVATIONS WHERE CERTAIN CLAIMS WERE FOUND UNSEARCHABLE <sup>14</sup>

This international search report has not been established in respect of certain claims under Article 17(2) (a) for the following reasons:

1.  Claim numbers \_\_\_\_\_ because they relate to subject matter <sup>14</sup> not required to be searched by this Authority, namely:

2.  Claim numbers \_\_\_\_\_ because they relate to parts of the international application that do not comply with the prescribed requirements to such an extent that no meaningful international search can be carried out <sup>14</sup>, specifically:

VI.  OBSERVATIONS WHERE UNITY OF INVENTION IS LACKING <sup>11</sup>

This International Searching Authority found multiple inventions in this international application as follows:

1.  As all required additional search fees were timely paid by the applicant, this international search report covers all searchable claims of the international application.

2.  As only some of the required additional search fees were timely paid by the applicant, this international search report covers only those claims of the international application for which fees were paid, specifically claims:

3.  No required additional search fees were timely paid by the applicant. Consequently, this international search report is restricted to the invention first mentioned in the claims; it is covered by claim numbers:

4.  As all searchable claims could be searched without effort justifying an additional fee, the International Searching Authority did not invite payment of any additional fee.

## Remark on Protest

The additional search fees were accompanied by applicant's protest.

No protest accompanied the payment of additional search fees.



# INTERNATIONAL SEARCH REPORT

International Application No PCT/SE87/00279

<b>I. CLASSIFICATION OF SUBJECT MATTER</b> (if several classification symbols apply, indicate all) <sup>6</sup> According to International Patent Classification (IPC) or to both National Classification and IPC <sup>4</sup> A 61 K 47/00, 9/22, 9/52										
<b>II. FIELDS SEARCHED</b> <div style="text-align: right; margin-right: 50px;">Minimum Documentation Searched <sup>7</sup></div> <table style="width: 100%; border-collapse: collapse;"> <tr> <td style="width: 25%; border-bottom: 1px solid black;">Classification System</td> <td style="border-bottom: 1px solid black;">Classification Symbols</td> </tr> <tr> <td style="border-bottom: 1px solid black;">IPC US C1</td> <td style="border-bottom: 1px solid black;">A 61 K 9/00, /10, /22, /52, 47/00 424: 14, 19, 38</td> </tr> </table> <div style="text-align: center; margin-top: 10px;">Documentation Searched other than Minimum Documentation to the Extent that such Documents are Included in the Fields Searched <sup>8</sup></div> <p style="margin-top: 20px;">SE, NO, DK, FI classes as above</p>		Classification System	Classification Symbols	IPC US C1	A 61 K 9/00, /10, /22, /52, 47/00 424: 14, 19, 38					
Classification System	Classification Symbols									
IPC US C1	A 61 K 9/00, /10, /22, /52, 47/00 424: 14, 19, 38									
<b>III. DOCUMENTS CONSIDERED TO BE RELEVANT <sup>9</sup></b> <table border="1" style="width: 100%; border-collapse: collapse;"> <thead> <tr> <th style="width: 10%; padding: 5px;">Category <sup>10</sup></th> <th style="width: 70%; padding: 5px;">Citation of Document, <sup>11</sup> with indication, where appropriate, of the relevant passages <sup>12</sup></th> <th style="width: 20%; padding: 5px;">Relevant to Claim No. <sup>13</sup></th> </tr> </thead> <tbody> <tr> <td style="text-align: center; vertical-align: top; padding: 5px;">A</td> <td style="padding: 5px;">DK, B, 143 438 (THE UPJOHN COMPANY) 24 August 1981 &amp; DE, 2512391 FR, 2265408</td> <td style="width: 20%;"></td> </tr> <tr> <td style="text-align: center; vertical-align: top; padding: 5px;">A</td> <td style="padding: 5px;">DE, A, 3 224 619 (FREUND INDUSTRIAL CO) 19 May 1983</td> <td style="width: 20%;"></td> </tr> </tbody> </table>		Category <sup>10</sup>	Citation of Document, <sup>11</sup> with indication, where appropriate, of the relevant passages <sup>12</sup>	Relevant to Claim No. <sup>13</sup>	A	DK, B, 143 438 (THE UPJOHN COMPANY) 24 August 1981 & DE, 2512391 FR, 2265408		A	DE, A, 3 224 619 (FREUND INDUSTRIAL CO) 19 May 1983	
Category <sup>10</sup>	Citation of Document, <sup>11</sup> with indication, where appropriate, of the relevant passages <sup>12</sup>	Relevant to Claim No. <sup>13</sup>								
A	DK, B, 143 438 (THE UPJOHN COMPANY) 24 August 1981 & DE, 2512391 FR, 2265408									
A	DE, A, 3 224 619 (FREUND INDUSTRIAL CO) 19 May 1983									
<table style="width: 100%; border-collapse: collapse;"> <tr> <td style="width: 50%; vertical-align: top; padding: 5px;"> <ul style="list-style-type: none"> <li>* Special categories of cited documents: <sup>10</sup></li> <li>"A" document defining the general state of the art which is not considered to be of particular relevance</li> <li>"E" earlier document but published on or after the international filing date</li> <li>"L" document which may throw doubts on priority claim(s) or which is cited to establish the publication date of another citation or other special reason (as specified)</li> <li>"O" document referring to an oral disclosure, use, exhibition or other means</li> <li>"P" document published prior to the international filing date but later than the priority date claimed</li> </ul> </td> <td style="width: 50%; vertical-align: top; padding: 5px;"> <ul style="list-style-type: none"> <li>"T" later document published after the international filing date or priority date and not in conflict with the application but cited to understand the principle or theory underlying the invention</li> <li>"X" document of particular relevance; the claimed invention cannot be considered novel or cannot be considered to involve an inventive step</li> <li>"Y" document of particular relevance; the claimed invention cannot be considered to involve an inventive step when the document is combined with one or more other such documents, such combination being obvious to a person skilled in the art.</li> <li>"g" document member of the same patent family</li> </ul> </td> </tr> </table>		<ul style="list-style-type: none"> <li>* Special categories of cited documents: <sup>10</sup></li> <li>"A" document defining the general state of the art which is not considered to be of particular relevance</li> <li>"E" earlier document but published on or after the international filing date</li> <li>"L" document which may throw doubts on priority claim(s) or which is cited to establish the publication date of another citation or other special reason (as specified)</li> <li>"O" document referring to an oral disclosure, use, exhibition or other means</li> <li>"P" document published prior to the international filing date but later than the priority date claimed</li> </ul>	<ul style="list-style-type: none"> <li>"T" later document published after the international filing date or priority date and not in conflict with the application but cited to understand the principle or theory underlying the invention</li> <li>"X" document of particular relevance; the claimed invention cannot be considered novel or cannot be considered to involve an inventive step</li> <li>"Y" document of particular relevance; the claimed invention cannot be considered to involve an inventive step when the document is combined with one or more other such documents, such combination being obvious to a person skilled in the art.</li> <li>"g" document member of the same patent family</li> </ul>							
<ul style="list-style-type: none"> <li>* Special categories of cited documents: <sup>10</sup></li> <li>"A" document defining the general state of the art which is not considered to be of particular relevance</li> <li>"E" earlier document but published on or after the international filing date</li> <li>"L" document which may throw doubts on priority claim(s) or which is cited to establish the publication date of another citation or other special reason (as specified)</li> <li>"O" document referring to an oral disclosure, use, exhibition or other means</li> <li>"P" document published prior to the international filing date but later than the priority date claimed</li> </ul>	<ul style="list-style-type: none"> <li>"T" later document published after the international filing date or priority date and not in conflict with the application but cited to understand the principle or theory underlying the invention</li> <li>"X" document of particular relevance; the claimed invention cannot be considered novel or cannot be considered to involve an inventive step</li> <li>"Y" document of particular relevance; the claimed invention cannot be considered to involve an inventive step when the document is combined with one or more other such documents, such combination being obvious to a person skilled in the art.</li> <li>"g" document member of the same patent family</li> </ul>									
<b>IV. CERTIFICATION</b> <table border="1" style="width: 100%; border-collapse: collapse;"> <tr> <td style="width: 50%; padding: 5px;">Date of the Actual Completion of the International Search  1987-08-18</td> <td style="width: 50%; padding: 5px;">Date of Mailing of this International Search Report  <b>1987-08-26</b></td> </tr> <tr> <td style="padding: 5px;">International Searching Authority  Swedish Patent Office</td> <td style="padding: 5px;">Signature of Authorized Officer <i>Agneta Tannerfeldt</i> Agneta Tannerfeldt</td> </tr> </table>		Date of the Actual Completion of the International Search  1987-08-18	Date of Mailing of this International Search Report  <b>1987-08-26</b>	International Searching Authority  Swedish Patent Office	Signature of Authorized Officer <i>Agneta Tannerfeldt</i> Agneta Tannerfeldt					
Date of the Actual Completion of the International Search  1987-08-18	Date of Mailing of this International Search Report  <b>1987-08-26</b>									
International Searching Authority  Swedish Patent Office	Signature of Authorized Officer <i>Agneta Tannerfeldt</i> Agneta Tannerfeldt									