

Nov. 10, 1959

V. V. MILLER

2,911,841

PORTABLE ELECTRIC HAND DRILL

Filed July 2, 1958

Fig. 1

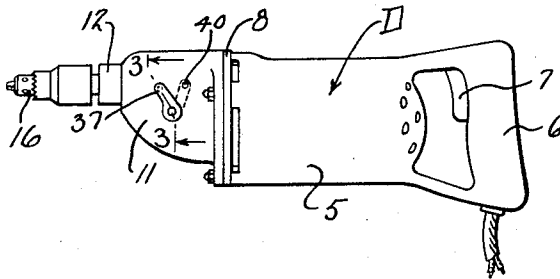

Fig. 2

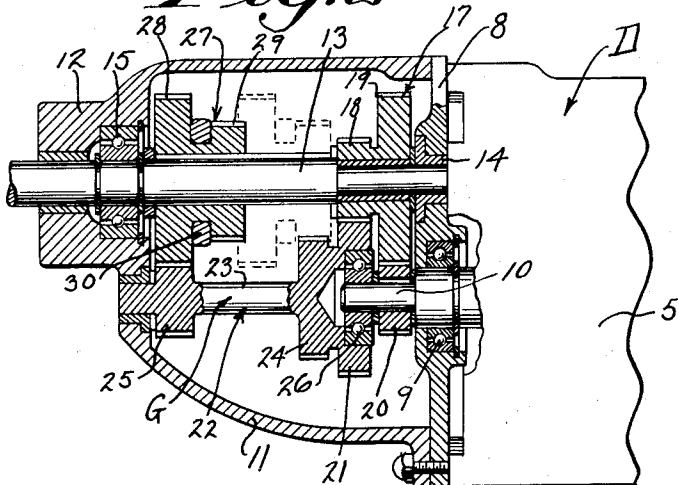

Fig. 3

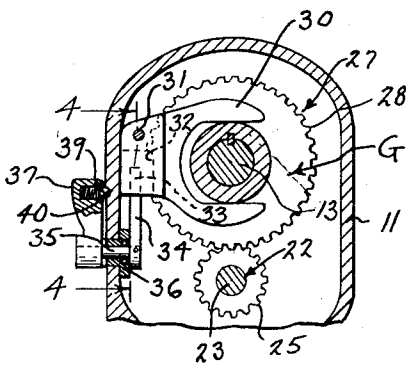
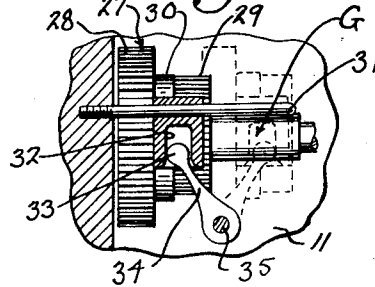

Fig. 4



INVENTOR
VANCE V. MILLER

BY *Wright & Wright*

ATTORNEYS

1

2,911,841

PORTABLE ELECTRIC HAND DRILL

Vance V. Miller, Milwaukee, Wis.

Application July 2, 1958, Serial No. 746,128

3 Claims. (Cl. 74-342)

This invention appertains to portable electric hand drills and is an improvement on the invention shown in my allowed application, Serial Number 529,485, filed August 19, 1955.

In my above-mentioned application for patent, means was provided for obtaining different desired speeds for the drill shaft and chuck from the electric motor and the application brought out the advantages of such means. In portable hand drills, it is of extreme importance that the speed reduction and speed change gearing be of a simple, compact and rugged order, and at the same time light in weight and one that can be instantly operated to obtain correct speed change, and one which will be easy and economical to manufacture.

It is, therefore, one of the primary objects of my present invention to provide a light weight, compact unit, which can be readily incorporated with a portable electric hand drill, and one in which the desired speed change and reduction can be readily had and one which will be exceptionally durable and efficient in use, and one which will be simple and economical to manufacture.

With these and other objects in view, the invention consists in the novel construction, arrangement and formation of parts, as will be hereinafter more specifically described and claimed, and illustrated in the accompanying drawing, in which drawing,

Figure 1 is a side elevational view of a portable electric hand drill embodying my improved invention;

Figure 2 is an enlarged fragmentary view partly in section showing my novel arrangement of the two speed and reduction gearing unit;

Figure 3 is a fragmentary transverse sectional view through the gearing taken on the line 3-3 of Figure 1, looking in the direction of the arrows, the view showing more particularly the means for shifting the speed change gear cluster, and

Figure 4 is a fragmentary detail longitudinal sectional view taken on the line 4-4 of Figure 3, looking in the direction of the arrows.

Referring to the drawing in detail, wherein similar reference characters designate corresponding parts throughout the several views, the letter G indicates one preferred type of my improved speed arrangement incorporated with an electric hand drill.

The electric hand drill D can be considered as of a type now in general use and the same will not be described in detail, but as illustrated the drill includes an outer shell or casing 5 having a hand grip 6. The hand grip 6 is provided with a trigger type control switch 7. The forward end of the shell 5 terminates in a front plate 8 and this plate carries bearings 9 for the armature shaft 10 of the electric drive motor (not shown), housed within the shell or casing 5.

The novel gearing G is enclosed within a housing 11 and this housing is rigidly secured to the front plate 8 of the drill 9 by the use of headed machine screws. The housing 11 is designed to conform to and blend with the

2

shape of the shell or casing 5 of the drill. The front of the housing 11 preferably tapers upwardly and terminates in a front nose portion 12.

Rotatably mounted within the housing 11 is a drill shaft 13 and this shaft is disposed above and at one side of the armature shaft 10. As best shown in Figure 2, the armature shaft 10 extends into the housing 11. The front plate 8 of the drill shell carries a suitable bearing 14 for the rear end of the drill shaft and the nose portion 12 of the housing 11 also carries a suitable bearing 15 for the shaft. The drill shaft extends forwardly of the housing 11 and is provided with any preferred type of chuck 16 for gripping a desired size and type of drill (not shown). Rotatably mounted on the inner end of the drill shaft 13 is a gear cluster 17 forming a part of the speed reduction gearing and this cluster includes gears 18 and 19 of different sizes. Keyed or otherwise fastened to the armature shaft 10 is a gear 20 and this gear meshes at all times with the gear 19. It is to be noted that the gear 20 is of a much smaller size than the gear 19. The gear 18 is in turn of a much smaller size than the gear 19 and this gear 18 meshes at all times with a gear 21, which is of a greater size than the gear 18. The gear 21 actually forms a part of a gear cluster 22 and this gear cluster 22 embodies a short countershaft 23 having formed thereon or secured thereto the gear 21, a gear 24 and a gear 25. The shaft is journaled at its forward end in the housing 11 and the rear end of the shaft or its gear 21, is rotatably mounted on the armature shaft 10 through the medium of a desired type of anti-friction bearing 26. At this time, it is to be noted that the gear 24 is of a considerably greater size than the gear 25, but of a smaller size than the gear 21.

Feathered on the drill shaft 13 for sliding movement is a gear cluster 27 and this cluster includes a gear 28 and a gear 29. The gear 28 is of a greater size than the gear 29 and is spaced from such gear for a purpose, which will later appear. In one position of the gear cluster 27 the gear 28 meshes with the gear 25 and in another position of the cluster 27, the gear 29 meshes with the gear 24 and in this position, the gear 28 moves out of meshing engagement with the gear 25.

For the moment, and referring to Figure 2, it can be seen that the drive for the drill shaft 13 is through gear 20, the gear 19, gear 18 to gear 21, through gear 25 to gear 28 which drives the drill shaft. Due to the size and proportions of the gears 20, 19, 18 and 21 a desired speed reduction is had. Due to the size and proportion of the gears 25 and 28, the drill shaft will be rotated at a definite selected low speed, say 400 r.p.m. With the gear 29 meshing with the gear 24 a definite selected high speed will be had for the drill shaft, say 1700 r.p.m. Thus, I am enabled to obtain not only a speed reduction from the electric motor, of a hand drill, which say is rotating at 15,000 r.p.m., but I am also enabled to obtain two definite selected speed changes best suitable for different sizes of drills.

It also can be seen that an exceptionally simple and compact arrangement of speed change and reduction gearing is had.

As brought out in the objects, it is important that a simple means be provided for shifting the gear cluster into its two different types of speed changes and that it is also important that such shifting mechanism be easy to operate and simple to assemble with the housing 11. At this time too, it might be noted that the cluster 27 can actually be shifted to a neutral position with the gear cluster between the gears 24 and 25 so as to stop rotation of the shaft 13 without cutting off the source of electrical energy to the motor of the hand drill.

The means for shifting the cluster 27 includes a shift

3

fork 30 which engages the cluster between the gears 28 and 29. This fork is so mounted that the same moves in a straight longitudinal path and in the same path as the gear cluster. To bring about this desired sliding movement, I support the fork 30 on a guide pin 31 which is threaded into the forward end of the housing 11 at one side of the drill shaft 13. The outer end of the fork is provided with a socket or pocket 32 which rockably receives the upper ball end 33 of a shift crank 34. The shift crank is keyed or otherwise fastened to a short rock shaft 35 that is mounted for turning movement in a bearing 36 carried by one side wall of the housing 11. The shaft 35 extends out of the housing 11 and has keyed or otherwise secured thereto a finger operated shift lever 37. By moving the shift lever 37 forwardly the gear cluster 27 can be moved forwardly with the gear 28 in meshing engagement with the gear 25 and by moving the lever 37 rearwardly the gear 29 can be brought into meshing engagement with the gear 24. It is preferred to hold the shift lever 37 in either one of these two positions and hence, the inner face of the shift lever can carry a spring pressed ball 39 for selective seating in spaced seats 40 formed in the outer face of the housing 11. When the shift lever 37 is between the two seats 40, then the gear cluster 27 is in its neutral position.

From the foregoing it can be seen that I have now provided an exceptionally simple, durable and compact speed change and gear reduction unit which is particularly applicable for hand drills.

Various changes in details may be made without departing from the spirit or the scope of this invention, but what I claim as new is:

1. A portable electric hand drill comprising an armature shaft, a rotatably mounted drill shaft disposed at one side of the armature shaft, a rotatably mounted countershaft in axial alignment with the armature shaft and rotatable independent thereof, a speed reduction gearing between the armature shaft and the countershaft including a gear cluster rotatably mounted on the drill shaft, two gears of different tooth ratio rotatable with said countershaft, and a gear cluster feathered on said drill shaft including two gears of different tooth ratio for sliding movement on said drill shaft to bring a desired gear of the cluster into meshing engagement with a desired gear on the countershaft, and means for shifting said gear cluster on the drill shaft.

4

2. A portable electric hand drill as defined in claim 1 and said means for shifting the gear cluster including a fork engaging the cluster between the two gears of the cluster, a stationary guide pin supporting said fork for sliding movement in a straight path parallel with the drill shaft, a rock shaft, a shift crank secured to the rock shaft in operative engagement with the fork, and a finger operated shift lever secured to said rock shaft.

3. A portable electric hand drill comprising an armature shaft, a casing, a detachable housing carried by the forward end of the casing into which the armature shaft extends, a countershaft in said housing and rotatably mounted therein arranged in axial alignment with the armature shaft and rotatable independent thereof, a drill shaft rotatably mounted in said housing arranged at one side of the armature shaft and the countershaft, speed reduction gearing operatively connecting the armature shaft with the countershaft, speed change mechanism in said housing including spaced gears on the countershaft having different tooth ratio and a gear cluster feathered on the drill shaft including two gears of different tooth ratio, the cluster being slidable on the drill shaft to bring a desired gear of the cluster into meshing engagement with a selected gear on the countershaft, and means for sliding the gear cluster on the drill shaft including a shift fork engaging the cluster between its two gears, means slidably supporting the fork for movement longitudinally of the housing and parallel with the drill shaft including a guide pin secured to the housing arranged in spaced parallel relation to the drill shaft, and means for sliding the fork on the guide pin including a rock shaft carried by the housing extending into and out of the housing, a shift crank secured to the inner end of the rock shaft having operative connection with the shift fork, and a finger operated shift lever disposed exteriorly of the housing and secured to the outer end of the rock shaft.

References Cited in the file of this patent

UNITED STATES PATENTS

1,581,927	Kollock	Apr. 20, 1926
2,486,254	Briskin et al.	Oct. 25, 1949

FOREIGN PATENTS

710,239	Great Britain	June 9, 1954
---------	---------------	--------------