



- (51) International Patent Classification:  
H04L 1/18 (2006.01) H04W 28/06 (2009.01)  
H04L 1/16 (2006.01)
- (21) International Application Number:  
PCT/IB2018/053131
- (22) International Filing Date:  
04 May 2018 (04.05.2018)
- (25) Filing Language: English
- (26) Publication Language: English
- (30) Priority Data:  
62/502,318 05 May 2017 (05.05.2017) US
- (71) Applicant: NOKIA TECHNOLOGIES OY [FI/FI];  
Karaportti 3, 02610 Espoo (FI).
- (71) Applicant (for LC only): NOKIA USA INC. [US/US]; 200  
South Mathilda Avenue, Sunnyvale, California 94086 (US).

- (72) Inventors: WU, Chunli; No.1 Wangjing East Road, Chaoyang District, Beijing 100096 (CN). TURPINEN, Samuli Heikki; Poolatie 3A, 91100 Ii (FI). MALKAMAKI, Esa; Riippakoivuntie 17 B, 02130 Espoo (FI). SEBIRE, Benoist Pierre; Roppongi Hills Mori Tower 41F, 6-10-1 Roppongi, Minato-Ku, Tokyo 106-6141 (JP).
- (81) Designated States (unless otherwise indicated, for every kind of national protection available): AE, AG, AL, AM, AO, AT, AU, AZ, BA, BB, BG, BH, BN, BR, BW, BY, BZ, CA, CH, CL, CN, CO, CR, CU, CZ, DE, DJ, DK, DM, DO, DZ, EC, EE, EG, ES, FI, GB, GD, GE, GH, GM, GT, HN, HR, HU, ID, IL, IN, IR, IS, JO, JP, KE, KG, KH, KN, KP, KR, KW, KZ, LA, LC, LK, LR, LS, LU, LY, MA, MD, ME, MG, MK, MN, MW, MX, MY, MZ, NA, NG, NI, NO, NZ, OM, PA, PE, PG, PH, PL, PT, QA, RO, RS, RU, RW, SA, SC, SD, SE, SG, SK, SL, SM, ST, SV, SY, TH, TJ, TM, TN, TR, TT, TZ, UA, UG, US, UZ, VC, VN, ZA, ZM, ZW.
- (84) Designated States (unless otherwise indicated, for every kind of regional protection available): ARIPO (BW, GH,

(54) Title: RADIO LINK CONTROL STATUS REPORTING

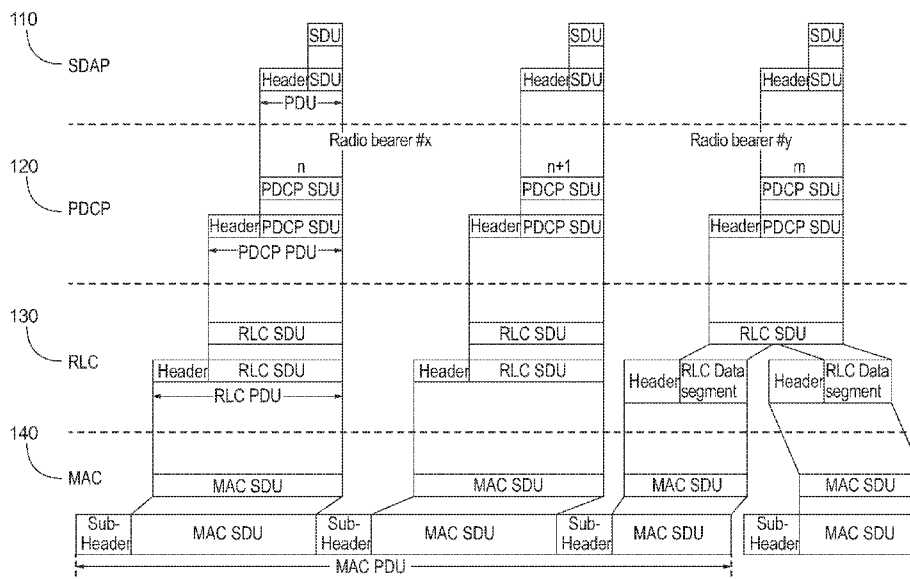

Figure 1

(57) **Abstract:** Various communication systems may benefit from an enhanced radio link control status report. A method may include determining a negative acknowledgment sequence number range. The negative acknowledgment sequence number range may include a plurality of consecutive radio link control missing sequence numbers. The method may also include determining at least one of a negative acknowledgment end sequence number when the plurality of consecutive radio link control missing sequence numbers exceeds the negative acknowledgment sequence number range. In addition, the method may include sending a radio link control status report comprising at least one of a negative acknowledgment sequence number, the negative acknowledgment sequence number range, or the negative acknowledgment end sequence number when the plurality of consecutive radio link control missing sequence numbers exceeds the at least one negative acknowledgment sequence number range.



GM, KE, LR, LS, MW, MZ, NA, RW, SD, SL, ST, SZ, TZ, UG, ZM, ZW), Eurasian (AM, AZ, BY, KG, KZ, RU, TJ, TM), European (AL, AT, BE, BG, CH, CY, CZ, DE, DK, EE, ES, FI, FR, GB, GR, HR, HU, IE, IS, IT, LT, LU, LV, MC, MK, MT, NL, NO, PL, PT, RO, RS, SE, SI, SK, SM, TR), OAPI (BF, BJ, CF, CG, CI, CM, GA, GN, GQ, GW, KM, ML, MR, NE, SN, TD, TG).

**Published:**

- *with international search report (Art. 21(3))*
- *before the expiration of the time limit for amending the claims and to be republished in the event of receipt of amendments (Rule 48.2(h))*
- *in black and white; the international application as filed contained color or greyscale and is available for download from PATENTSCOPE*

## RADIO LINK CONTROL STATUS REPORTING

## BACKGROUND:

5 **Field:**

[0001] Various communication systems may benefit from an enhanced radio link control status report. For example, it may be helpful to improve the content of the radio link control status report in order to better manage New Radio technology.

10 **Description of the Related Art:**

[0002] Recent third generation partnership project (3GPP) technology, such as fifth generation (5G) New Radio (NR) technology, have focused on the NR user plane (UP). In Long Term Evolution (LTE) or LTE-Advanced (LTE-A), the user plane included the following three layers: a packet data convergence protocol (PDCP), a radio link control (RLC), and a medium access control (MAC). In addition to the three above layers, NR also allows for a service data adaptation protocol (SDAP) placed above the NR PDCP to help facilitate a new quality of service (QoS) framework. The SDAP may also perform mapping between a QoS flow and a data radio bearer, and mark the QoS flow identification in both downlink and uplink packets.

[0003] In the NR RLC layer, segment offset (SO) based segmentation may be used for initial  
20 segmentation and/or re-segmentation. Segments of the same service data unit (SDU) in NR are therefore associated with the same RLC sequence number (SN). In LTE, on the other hand, involving framing information based initial segmentation, different SNs are assigned to SDU segments.

[0004] Unlike LTE RLC, the NR RLC layer does not support concatenation of RLC SDUs. Concatenation is the process of joining two or more SDUs together. Because of the lack of  
25 concatenation, there can be many RLC packet data units (PDUs) originating from a single RLC entity or logical channel that are mapped to a single transport block in the MAC layer. One lost transport block may therefore amount to many RLC PDUs lost.

## BRIEF DESCRIPTION OF THE DRAWINGS:

30 [0005] For proper understanding of the invention, reference should be made to the accompanying drawings, wherein:

[0006] Figure 1 illustrates a user plane architecture.

[0007] Figure 2 illustrates an example of RLC segmentation.

[0008] Figure 3 illustrates an example of a status report according to certain embodiments.

[0009] Figure 4 illustrates an example of a flow diagram according to certain embodiments.

[0010] Figure 5 illustrates an example of a flow diagram according to certain embodiments.

5 [0011] Figure 6 illustrates an example of a flow diagram according to certain embodiments.

[0012] Figure 7 illustrates an example of a flow diagram according to certain embodiments.

[0013] Figure 8 illustrates an example of a system according to certain embodiments.

#### DETAILED DESCRIPTION

10 [0014] In order to account for the differences between the LTE RLC and the NR RLC, the content of a RLC status report sent by a network entity and a user equipment may be improved. For example, the status report may include a negative acknowledgement SN range, and may also conditionally include a segment offset. The negative acknowledgment SN range may indicate a number of multiple consecutive missing RLC SNs after a reference SN, and optionally a negative acknowledgement SN  
15 end if the number of missing SNs exceeds an indicated range. The presence of the NACK\_SN end may be indicated by a codepoint of NACK\_SN\_RANGE, as described in Figure 3.

[0015] Figure 1 illustrates a user plane network architecture. In particular, Figure 1 illustrates a NR UP including SDAP 110, PDCP 120, RLC 130, and MAC 140. Figure 1 illustrates two different radio bearers, radio bearer #x and radio bearer #y. Radio bearer #x may have an  $n$  number of PDUs, while  
20 radio bearer #y may have an  $m$  number of PDUs. PDCP 120 sublayer may perform header compression and/or decompression, reordering, transfer of user data, ciphering and/or deciphering, as well as time based SDU discard. In embodiments involving dual connectivity, PDCP may also perform PDCP PDU routing to associated links. At least some of the above functions of the PDCP rely on a PDCP SN located in the PDCP header of the PDCP PDU.

25 [0016] Located below PDCP sublayer 120 lies RLC sublayer 130. RLC sublayer 130 may help to facilitate the transfer of upper layer PDUs and perform error correction through automatic repeat request (ARQ) for acknowledgment mode (AM) data transfer. RLC sublayer 130 can also perform segmentation and re-segmentation for unacknowledged mode (UM) and AM data transfers, reassembly of RLC SDUs, duplicate detection for UM and AM data transfers, and/or protocol error  
30 detection for AM data transfers. In certain embodiments, these functions performed by RLC sublayer 130 may rely or be based on an RLC SN derived from the RLC header of every RLC PDU.

[0017] Below PDCP sublayer 120 and RLC sublayer 130 lies MAC sublayer 140. MAC sublayer

140 includes mapping between logical channels and transport channels, multiplexing/demultiplexing MAC SDUs belonging to one or more different logical channels delivered to/from the physical layer on the transport channel. MAC sublayer 140 may also help to schedule information reporting, error correction through hybrid ARQ (HARQ), priority handling between logical channels of one user equipment, priority handling between user equipment by means of dynamic scheduling, transport format selection, and/or padding.

5 [0018] As discussed above, SDAP 110 has been added on top of the PDCP sublayer 110 in NR technology to support a new QoS framework. SDAP 110 may help to facilitate mapping between a QoS flow and a data radio bearer. SDAP 110 may also help to facilitate marking QoS flow identification in both downlink and uplink packets.

10 [0019] Figure 2 illustrates an example of RLC segmentation. In particular, Figure 2 compares two different RLC SDUs in LTE 201 to two different RLC SDUs in NR 202. In LTE, the RLC in an AM mode made be responsible for both concatenation and segmentation to produce AMD PDUs. As can be seen, each PDU is assigned a different sequence number. As such, each RLC data segment within LTE RLC SDU 1 and LTE RLC SDU 2 has its own unique sequence number. Resegmentation may occur when an AMD PDU to be transmitted is too large to fit the transport block. RLC may then produce AMD PDU segments, with each segment using the same SN as the original PDU. As shown in Figure 2, SN1 may be assigned to data segment 211, SN2 may be assigned to data segment of 212, SN3 may be assigned to data segment 213, and SN4 may be assigned to data segment 214.

15 [0020] On the other hand, each RLC data segment of the NR RLC SDU 1 and NR RLC SDU 2 may not be associated with different sequence numbers. As can be seen in Figure 2, both RLC data segments 221 and 222 are associated with SN1, while RLC data segments 223 and 224 are associated with SN2. In addition, as can be seen in Figure 1, NR RLC SDUs may include a segment control (SC) field that indicates whether the PDU segment is one of at least a first segment, a middle segment, or a last segment. The NR RLC SDUs may also include an SO offset when needed. SO may be used to identify the segment within the segmented original PDU. For example, the first RLC data segment of a new SDU may omit the SO associated with the data segment.

20 [0021] In accordance with LTE, the transmitting side of the AM RLC entity forms AMD PDUs from RLC SDUs. The transmitting side of the AM RLC entity may segment and/or concatenate the RLC SDUs so that the AMD PDUs fit within the total size of the RLC PDUs indicated by a lower layer at the particular transmission opportunity notified by the lower layer. In other words, the lower layer may determine the maximum size of the PDU. The transmitting side of the AM RLC entity may also support

30

retransmission of the RLC PDUs. When a given RLC PDU to be retransmitted does not fit within the total size of RLC PDU indicated by lower layer at the particular transmission opportunity notified by the lower layer, the AM RLC entity may be segmented or resegmented into AMD PDU segments. The number of segments into which the SDU is divided may not be limited.

5 [0022] When the transmitting side of an AM RLC entity forms AMD PDUs from RLC SDUs received from an upper layer, or AMD PDU segments from RLC PDUs to be retransmitted, the transmitting side may include in the RLC PDU relevant RLC headers. In LTE using framing information based segmentation, a new transmission may always be an AMD PDU even though it may include one or more SDU segments. In some embodiments RLC status reports may be transmitted  
10 between peer RLC entities. In the RLC status report, only a negative acknowledgment SN can follow an SO field in order to indicate which segment may be received from the original AMD PDU. The RLC status report may also include the acknowledgment SN field, which may indicate that the SN of the next not received RLC PDU which is not indicated as missing in the status report.

[0023] In accordance with LTE, t-ordering may be started when a gap is created, and the SN that  
15 started the t-reordering may be recorded. t-reordering may be a timer that may be used by the receiving side of the AM RLC entity to detect loss of RLC PDUs at the lower layer. The gap may be caused by a missing or yet to be received RLC segment. In embodiments involving LTE technology, at time period 1 SN1 may be received. VR(H), which is a state variable holding the value of the SN following the SN of the RLC data PDU with the highest SN among received RLC data PDUs, may equal two.  
20 VR(R), which is the state variable holding the value of the SN following the last in-sequence completely received AMD PDU that serves as the lower edge of the receiving window, may also equal two. In addition VR(MS), which may hold the highest possible value of the SN that can be indicated by an acknowledgment SN when a status report may be constructed, may be equal to two as well.

[0024] At time period 2, SN3 may be received without SN2 being received. VR(H) may equal 4,  
25 VR(R) may equal 2, VR(MS) may equal 2, while t-reordering may be started and VR(X), which may hold the value of the SN following the SN of the RLC data PDU which triggered t-reordering, may be equal to 4. At time period 3, at the expiration of t-reordering, a status report may indicate an acknowledgment sequence number that may equal 4, while the negative acknowledgment sequence number may be equal to 2.

30 [0025] While the process describe above may be used in LTE, the procedure may be problematic for NR. For NR, the gap can be created by a segment. For example, At time period 1, SN1 may be received, but segmentation information SC may indicate that the received transmission may not include a full

SDU. SC may be a segmentation control field which indicates whether the received PDU contains a full SDU or a SDU segment and more precisely whether the SDU segment is the first, middle, or the last SDU segment. VR(H) may equal to 2, VR(R) may equal to 1, and/or VR(MS) may equal to 1. At time period 2, SN2 may be received but the SC may indicate that the received transmission may not include a full SDU, while the second segment of SN1 may be missing. In this embodiment, VR(H) may equal to 3, VR(R) may equal to 1, VR(MS) may equal to 1, while t-reordering may be started, and VR(X) may be equal to 2, which may be the SN following the SN that triggers the start of t-reordering.

**[0026]** At time period 3, when the t-reordering expires the status report indicates that an acknowledgment SN may be equal to 3, negative acknowledgment SN may be equal to 1, and the SO may be equal to X, which indicates that the second segment of SN1 may be missing. The value of X may be deduced or derived from reception of the first segment of SN1. A negative acknowledgment SN may also be equal to 2, while SO may be equal to Y, which indicates that the second segment of SN2 may be missing. Y may be deduced or derived from the reception of the first segment of SN2.

**[0027]** An acknowledgment of SN3 may be reported, and a negative acknowledgment of the second segment of SN2 may also be reported as missing. However, there may be a case that the second segment of SN2 may actually not even have been sent by the transmitter side yet during the duration of the t-reordering that started upon the reception of the first segment of SN2. Alternatively, the second segment that has just been sent, but the receiver side may not take the corresponding HARQ process carrying the second segment into account when constructing the status report.

**[0028]** In certain embodiments, the receiving side of each AM RLC entity may maintain various state variables, such as a receive state variable VR(R), a maximum acceptable receive state variable VR(MR), a t-reordering state variable VR(X), a maximum status transmit state variable VR(MS), and/or a highest received state variable VR(H). The various state variables may be described in 3GPP TS 36.322. 3GPP TS 36.322 is hereby incorporated by reference in its entirety.

**[0029]** VR(R) may hold the value of the SN following the last in-sequence completely received AMD PDU and/or RLC SDU, and it may serve as the lower edge of the receiving window. The VR(R) may be initially set to zero, and may be updated whenever the AM RLC entity receives an AMD PDU/RLC SDU with an SN equal to VR(R). VR(MR) may equal the VR(R) plus the AM\_Window\_Size, and may hold the value of the SN of the first AMD PDU/RLC SDU that may be beyond the receiving window. VR(MR) may also serve as the higher edge of the receiving window. VR(X) may be a variable that holds the value of the SN following the SN of the RLC data PDU which triggered t-

reordering, while VR(MS) may have the highest possible value of the SN which can be indicated by an acknowledgment SN (ACK\_SN) when a status report may be constructed. VR(MS) may be initially set to 0. VR(H) may hold the value of the SN following the SN of the RLC data PDU with the highest SN among received RLC data PDUs.

5 [0030] In certain embodiments, when a gap is created, such as an SN gap or a byte segment gap, t-reordering may be started, and the SN and/or the SO may be recorded, which indicates the next PDU/SDU SN or the next bytes of a segment of a PDU/SDU that may be received. The next PDU/SDU SN or the next bytes of a segment of a PDU/SDU that may be received may not to be reported as missing in the status report. The gap may be either a segment or a whole PDU/SDU. In NR technology,  
10 instead of t-reordering any other timer may be used, such as t-statusreport or any other equivalent, since no actual reordering may be performed in the NR RLC. The recorded SO may indicate the end byte of a received segment or the next byte not yet received.

[0031] In some embodiments, the status report may include the ACK\_SN. In addition, the status report may also optionally include an SO of the ACK\_SN when the next not received and/or not  
15 reported as missing may be a segment of the ACK\_SN. The SO may indicate the end byte of a received segment or the start byte of a not yet received and/or not yet reported segment that may not be reported as missing in the status report. In certain embodiments, as shown in Figure 3, the SO may follow the ACK\_SN in the status report. Presence of SO may be indicated with a 1 bit flag or a different CPT value that may be allocated. In certain other embodiments, the SO may always be present in the status  
20 report.

[0032] In some embodiments, the status report may include a bit that may indicate that the first segment of ACK\_SN has been received, and that the SO field may be excluded to indicate that the next not received PDU is a segment. For example, such embodiment may be applicable when a first AMD PDU segment may have been received, but not an AMD PDU segment including bytes  
25 immediately following the first AMD PDU segment.

[0033] In other embodiments, two bits could be encoded to form a framing information type field in an RLC status report, which may indicate whether the ACK\_SN may be reported as a full SDU or as a first, middle, or last segment of the SDU. The framing information may be combined either preceding to or following the transmission of the ACK\_SN. In an embodiment including a full SDU or a first  
30 segment, the SO field may not follow. In embodiments including a middle or a last segment, the SO field may follow. In other embodiments indicating a middle segment, there may be another SO field including both the SO\_start and/or the SO\_end values. A separate NACK\_SN may then not be required

for the first or a middle segment of the SDU, as the missing segment may be deduced from that information.

**[0034]** In some embodiments, the NACK\_SN in the RLC status report may be allowed to be equal to ACK\_SN in the same status report. The NACK\_SN may indicate a missing segment before the highest  
5 byte that has already been received for the ACK\_SN, and indicated by the SO following the ACK\_SN. In certain embodiments, the SO field for ACK\_SN may not be encoded but the NACK\_SN equal to ACK\_SN may be used to report the missing segments of the ACK\_SN. In such embodiments, NACK\_SN may equal ACK\_SN when the first segment of ACK\_SN has been received and/or the last  
10 segment of the ACK\_SN is received. In other words, in SO based segmentation for NR, certain embodiments may have the same SN as ACK\_SN and NACK\_SN, but with different SOs to address an embodiment in which the middle segment missing and the next expected segment may be from the same SDU.

**[0035]** In one example, RLC SDU 1 may be segmented into SN1 having a first segment and a second segment, and RLC SDU 2 may be segmented into SN2 with a first segment and a second segment.  
15 When a first segment of SN2 may be received, a second segment of SN1 may be missing, and t-statusreport may be started, SN2 with an SO equal to Y may be recorded. Y may be the next segment of the SN2 that has yet to be received. In some embodiments, Y may be deduced from the reception of the first segment of the SN2. When t-statusreport expires, the ACK\_SN may be set to 2 and SO may be set to Y, indicating that the second segment of SN2 may not be reported as missing in this status  
20 report, while NACK\_SN may be set to 1, while SO may be set to X. X may indicate that the second segment of the SN1 may be missing. Based on the ACK\_SN and the NACK\_SN, the transmission side may know the status of the PDUs before the SN may be equal to 2 and the SO may be equal to Y.

**[0036]** In certain embodiments, in a status report the same SN may be applied as an ACK\_SN and a NACK\_SN. In such embodiments, either the middle segment or end segment of the SDU may have  
25 been received while the first segment or the middle segment may not have been received. In some embodiments, in order to correctly start the status report timer and correctly report the receiver status, some of the RLC state variables may have to be updated to include both a SN and an SO. For example, VR(H) and VR(MS) may include an SO when a complete RLC SDU has not been received.

**[0037]** Including both the SN and the SO may allow the status report to correctly report the receiver  
30 status of the one or more received segment. As discussed above, only including the SN without the SO may not be enough for an ACK\_SN since SO based segments may have the same SN. The status report may not request transmission of a segment that has yet to be transmitted at all, or a segment that was

transmitted after a predetermined time in which the receiving RLC entity did not take any additional transmission into account when constructing the status report. The format of the status report may then be optimized by using SO based segmentation.

**[0038]** The status report used in LTE generates high overhead since each SDU may need to be indicated as missing with its own NACK-SN. In an NR RLC, which does not utilize concatenation, this increased overhead may decrease network efficiency. In certain embodiments, therefore, the RLC status report may include both NACK\_SN range as well as a NACK\_SN\_start and/or NACK\_SN\_end. The presence of NACK\_SN\_range field in the STATUS PDU, for example, may be indicated by an extension bit preceding the start of each new NACK\_SN. A status report may be referred to as a STATUS PDU. In other embodiments, the NACK\_SN\_range field may be present following each new NACK\_SN with an option all 0 bits indicating only one SN negative acknowledgment. For example, a bit sequence of 000 may follow each new NACK\_SN if the only one SN may be negatively acknowledged.

**[0039]** When the amount of consecutive NACK\_SNs to be indicated may exceed the space given by the NACK\_SN\_range, the NACK\_SN\_range special value 000 may be used to indicate the existence of the NACK\_SN\_end. This may be applicable when the presence of NACK\_SN\_range field in the STATUS PDU is indicated by an extension bit. In some other embodiments, the existence of the NACK\_SN\_end field may be indicated via the last value of NACK\_SN\_range. For example, the last value of the NACK\_SN\_range may be shown as a bit sequence of 1s, such as 111. This may be applicable when the NACK\_SN\_range field is always present in the STATUS PDU following each NACK\_SN.

**[0040]** The NACK\_SN\_range field size may be configurable by the network. In some embodiments, for example, the NACK\_SN\_range field size may be determined by the RLC SN size configured, and the byte of the last bit of the corresponding NACK\_SN may be filled so as to end in the status report. The above embodiment may ensure that the byte alignment may be achieved. In another embodiments, a control type field, which may be located in a header, may specify the length of NACK\_SN\_range field used in a status report.

**[0041]** Figure 3 illustrates an example of a status report. In particular, Figure 3 illustrates an embodiment in which the existence of NACK\_SN\_range field may not be explicitly indicated by an extension bit, but rather the NACK\_SN\_range field may follow every NACK\_SN indicated. The status report may include an RLC control PDU header and a STATUS PDU payload. RLC control PDU header may include, for example, data or control (D/C) field that specifies whether the PDU is a data

or a control PDU. The RLC control PDU header may also include a control PDU type (CPT) field that specifies the control PDU type. The STATUS PDU payload may start with the first bit following the RLC control PDU header.

**[0042]** As can be seen in Figure 3, NACK\_SN\_range field 310 may follow every NACK\_SN field 5 320 indicated. In certain embodiments, consecutive NACK\_SNs do not exceed the maximum indicated by NACK\_SN\_Range. In embodiments in which consecutive NACK\_SNs exceed the maximum, however, the NACK\_SN\_end field may follow the NACK\_SN\_range value '111'. In embodiments in which consecutive NACK\_SNs do not exceed the maximum that may be indicated by the NACK\_SN\_range, SO\_start and SO\_end fields may follow the set. In other embodiments, 10 consecutive NACK\_SNs exceed the maximum that can be indicated by NACK\_SN\_range, the NACK\_SN\_end field follows with NACK\_SN range value '111'. SO\_start field and SO\_end field may follow the set.

**[0043]** The E1 bit in Figure 3 may indicate whether a set of E bits, NACK\_SN, NACK\_SN\_range, NACK\_SN\_end, and/or SO fields may or may not follow. The E2 bit may indicate whether SO fields 15 may follow the corresponding set of NACK\_SN, NACK\_SN\_range, and/or possible NACK\_SN\_end. When E2 indicates that the SO fields may follow the corresponding set of NACK\_SN, NACK\_SN\_range, and possible NACK\_SN\_end, the SO\_start field that may relate to the end SN of the NACK\_SN\_range, and/or SO\_end field that may relate to the NACK\_SN or other way around. The end SN of the NACK\_SN\_range, in some examples, may be indicated by NACK\_SN\_range itself 20 or with the NACK\_SN\_end.

**[0044]** In some other embodiments, a restriction may be specified that NACK\_SN\_range or NACK\_SN\_end may not be used when SO\_start and SO\_end may follow the NACK\_SN. For example, when E2 is set to 1, SO\_start and SO\_end may follow the NACK\_SN. In certain 25 embodiments, the status report may also optionally or conditionally include a SO of an ACK\_SN when the next not yet received and/or not yet reported SDU segment is missing. In the embodiment shown in Figure 3, the overhead may be minimized in all possible scenarios, including when consecutive or non-consecutive PDUs are lost.

**[0045]** Figure 4 illustrates an example of a flow diagram according to certain embodiments. In particular, Figure 4 illustrates a method performed by a receiving RLC entity. In step 410, the receiving 30 entity may determine a negative acknowledgment sequence number range. The negative acknowledgment sequence number range may include a plurality of consecutive radio link control missing sequence numbers. In step 420, the receiving entity may determine at least one of a negative

acknowledgment end sequence number when the plurality of consecutive radio link control missing sequence numbers exceeds the at least one negative acknowledgment sequence number range.

**[0046]** In step 430, the receiving entity may send a radio link control status report comprising at least one of a negative acknowledgment sequence number, the negative acknowledgment sequence number  
5 range, or the negative acknowledgment end sequence number when the plurality of consecutive radio link control missing sequence numbers exceeds the negative acknowledgment sequence number range. When the negative acknowledgment sequence number range is exceeded, the negative acknowledgment end sequence number may follow the negative acknowledgment sequence number range in the status report. The negative acknowledgment sequence number may indicate a negative  
10 acknowledgment start sequence number. When the negative acknowledgment sequence number range is exceeded, the negative acknowledgment end sequence number may indicate an end value of the negative acknowledgment sequence number range.

**[0047]** Figure 5 illustrates an example of a flow diagram according to certain embodiments. In particular, Figure 5 illustrates a method performed by a transmitting RLC entity. In step 510, the  
15 transmitting entity may transmit the segmented service data units comprising radio link control sequence numbers. In step 520, the transmitting entity may receive a radio link control status report comprising at least one of a negative acknowledgment sequence number, a negative acknowledgment sequence number range, or a negative acknowledgment end sequence number when a plurality of consecutive radio link control missing sequence numbers exceeds the at least one negative  
20 acknowledgment sequence number.

**[0048]** Figure 6 illustrates an example of a flow diagram according to certain embodiments. In particular, Figure 6 illustrates a method performed by a receiving RLC entity. In step 610, the receiving entity may receive at least one segment of a service data unit having a sequence number. The service data unit may include at least one other segment. In step 620, the receiving entity may determining to  
25 include a segment offset in a radio link control status report when the at least one other segment of the service data unit has not yet been received.

**[0049]** In step 630, the receiving entity may transmit a radio link control status report comprising at least one of an acknowledgement of the sequence number and the segment offset when the at least one other segment of the service data unit has not yet been received. In addition, the receiving entity may  
30 also transmit the radio link control status report comprising a segment offset start and a segment offset end to indicate the received at least one segment when the received at least one segment is located in a middle of the service data unit. The received at least one segment may be a last segment of the service

data unit. In certain embodiments, when the received at least one segment is a first segment of the service data unit, the segment offset may indicate an end byte of the received at least one segment.

[0050] Figure 7 illustrates an example of a flow diagram according to certain embodiments. In particular, Figure 7 illustrates a method performed by a transmitting RLC entity. In step 710, the transmitting entity may transmit at least one segment of a service data unit having a sequence number. The service data unit may comprise at least one other segment. In step 720, the transmitting entity may receive a radio link control status report comprising at least one of an acknowledgement of the sequence number and a segment offset when at least one other segment of the service data unit has not yet been transmitted. In addition, the method may also include receiving the radio link control status report comprising a segment offset start and a segment offset end to indicate the transmitted at least one segment when the transmitted at least one segment is located in a middle of the service data unit.

[0051] Applying the LTE procedure for RLC status reporting in NR may lead to inaccurate reporting of segments that have either not been or have just been sent. Certain embodiments, therefore, avoid the early reporting of not transmitted yet or still ongoing segment should be avoided. To mimic the behavior in LTE, simple extensions on top of the LTE baseline may be used to keep track of the highest SO along with the highest SN among the received RLC data PDUs. In such embodiments, t-reordering should be started when a gap is created by either a segment or a full PDU, and ACK\_SN field in the status report should optionally follow an SO field which may indicate the byte offset of the next not received segment of ACK\_SN, which may not be reported as missing in the status report.

[0052] In some embodiments, a receiving RLC entity may keep track of the highest SO along with the highest SN among the received RLC data PDUs to be used in the status report. As discussed above, t-reordering may be started when a gap is created by either a segment or a full PDU, and the SO of the next expected segment may be recorded for the status report. In other embodiments, a ACK\_SN may follow an optional SO field in the RLC STATUS PDU to indicate the byte offset of the next not received segment of ACK\_SN, which may not be reported as missing in the status report.

[0053] Figure 8 illustrates a system according to certain embodiments. It should be understood that each signal or block in Figures 1-7 may be implemented by various means or their combinations, such as hardware, software, firmware, one or more processors and/or circuitry. In one embodiment, a system may include several devices, such as, for example, network entity 820 or user equipment (UE) 810. The system may include more than one UE 810 and more than one

network entity 820. Network entity 820 may be a base station, a network node, an access point, an access node, a NR NodeB, a server, a host, or any other network core entity that may communicate with the UE. The network entity may include the user plane radio protocol layers shown in Figure 1. In certain embodiments, the network entity may be an RLC transmitting entity.

5 [0054] Each of these devices may include at least one processor or control unit or module, respectively indicated as 811 and 821. At least one memory may be provided in each device, and indicated as 812 and 822, respectively. The memory may include computer program instructions or computer code contained therein. One or more transceiver 813 and 823 may be provided, and each device may also include an antenna, respectively illustrated as 814 and 824. Although only  
10 one antenna each is shown, many antennas and multiple antenna elements may be provided to each of the devices. Other configurations of these devices, for example, may be provided. For example, network entity 820 and UE 810 may be additionally configured for wired communication, in addition to wireless communication, and in such a case antennas 814 and 824 may illustrate any form of communication hardware, without being limited to merely an antenna.

15 [0055] Transceivers 813 and 823 may each, independently, be a transmitter, a receiver, or both a transmitter and a receiver, or a unit or device that may be configured both for transmission and reception. The transmitter and/or receiver (as far as radio parts are concerned) may also be implemented as a remote radio head which is not located in the device itself, but in a mast, for example. The operations and functionalities may be performed in different entities, such as nodes,  
20 hosts or servers, in a flexible manner. In other words, division of labor may vary case by case. One possible use is to make a network node deliver local content. One or more functionalities may also be implemented as virtual application(s) in software that can run on a server.

[0056] A user device or UE 810 may be a mobile station (MS) such as a mobile phone or smart phone or multimedia device, an IoT cellular device, a computer, such as a tablet, provided with  
25 wireless communication capabilities, personal data or digital assistant (PDA) provided with wireless communication capabilities, portable media player, digital camera, pocket video camera, navigation unit provided with wireless communication capabilities or any combinations thereof. In other embodiments, the user equipment may be replaced with a machine communication device that does not require any human interaction, such as a sensor, meter, or robot. In certain  
30 embodiments, the UE may be an RLC receiving entity.

[0057] In some embodiments, an apparatus, such as a user equipment or a network entity, may include means for carrying out embodiments described above in relation to Figures 1-7. In certain

embodiments, at least one memory including computer program code can be configured to, with the at least one processor, cause the apparatus at least to perform any of the processes described herein.

5 [0058] Processors 811 and 821 may be embodied by any computational or data processing device, such as a central processing unit (CPU), digital signal processor (DSP), application specific integrated circuit (ASIC), programmable logic devices (PLDs), field programmable gate arrays (FPGAs), digitally enhanced circuits, or comparable device or a combination thereof. The processors may be implemented as a single controller, or a plurality of controllers or processors.

10 [0059] For firmware or software, the implementation may include modules or unit of at least one chip set (for example, procedures, functions, and so on). Memories 812 and 822 may independently be any suitable storage device, such as a non-transitory computer-readable medium. A hard disk drive (HDD), random access memory (RAM), flash memory, or other suitable memory may be used. The memories may be combined on a single integrated circuit as the processor, or may be separate therefrom. Furthermore, the computer program instructions may be stored in the memory and which may be processed by the processors can be any suitable form of computer program code, for example, a compiled or interpreted computer program written in any suitable programming language. The memory or data storage entity is typically internal but may also be external or a combination thereof, such as in the case when additional memory capacity is obtained from a service provider. The memory may be fixed or removable.

20 [0060] The memory and the computer program instructions may be configured, with the processor for the particular device, to cause a hardware apparatus such as network entity 820 or UE 810, to perform any of the processes described above (see, for example, Figures 1-7). Therefore, in certain embodiments, a non-transitory computer-readable medium may be encoded with computer instructions or one or more computer program (such as added or updated software routine, applet or macro) that, when executed in hardware, may perform a process such as one of the processes described herein. Computer programs may be coded by a programming language, which may be a high-level programming language, such as objective-C, C, C++, C#, Java, etc., or a low-level programming language, such as a machine language, or assembler. Alternatively, certain embodiments may be performed entirely in hardware.

30 [0061] The above embodiments may provide for significant improvements to the functioning of a network and/or to the functioning of the network entities within the network, or the user equipment communicating with the network. For example, the above embodiments may help to minimize the

overhead in all possible scenarios, including scenarios when consecutive or non-consecutive PDUs may be lost. Some embodiments may also allow for correct reporting via a status report of the segments received by the receiving entity. The status report may not request the retransmission of a segment that has yet to be transmitted at all, or that was received by the receiving entity after the receiving entity stopped taking into account further transmissions.

5 **[0062]** The features, structures, or characteristics of certain embodiments described throughout this specification may be combined in any suitable manner in one or more embodiments. For example, the usage of the phrases “certain embodiments,” “some embodiments,” “other embodiments,” or other similar language, throughout this specification refers to the fact that a particular feature, structure, or characteristic described in connection with the embodiment may be included in at least one  
10 embodiment of the present invention. Thus, appearance of the phrases “in certain embodiments,” “in some embodiments,” “in other embodiments,” or other similar language, throughout this specification does not necessarily refer to the same group of embodiments, and the described features, structures, or characteristics may be combined in any suitable manner in one or more embodiments.

15 **[0063]** One having ordinary skill in the art will readily understand that the invention as discussed above may be practiced with steps in a different order, and/or with hardware elements in configurations which are different than those which are disclosed. Therefore, although the invention has been described based upon these preferred embodiments, it would be apparent to those of skill in the art that certain modifications, variations, and alternative constructions would  
20 be apparent, while remaining within the spirit and scope of the invention. Although the above embodiments refer to 5G NR technology, the above embodiments may also apply to any other 3GPP technology, such as IoT technology, LTE, LTE-advanced, and/or fourth generation (4G) technology.

**[0064]** Partial Glossary

25 **[0065]** 3GPP 3rd generation partnership project

**[0066]** MAC Medium Access Control

**[0067]** NR New Radio

**[0068]** PDCP Packet Data Convergence Protocol

**[0069]** PDU Protocol Data Unit

30 **[0070]** RLC Radio Link Control

**[0071]** SDU Service Data Unit

**[0072]** TBS Transport Block Size

[0073] AM Acknowledged Mode

[0074] CA Carrier Aggregation

[0075] DC Dual Connectivity

[0076] HARQ Hybrid ARQ

5 [0077] SN Sequence Number

[0078] TTI Transmission Time Interval

[0079] UM Unacknowledged Mode

[0080] According to a first embodiment, a method may include determining a negative acknowledgment sequence number range. The negative acknowledgment sequence number range includes a plurality of consecutive radio link control missing sequence numbers. The method may also include determining at least one of a negative acknowledgment end sequence number when the plurality of consecutive radio link control missing sequence numbers exceeds the negative acknowledgment sequence number range. In addition, the method may include sending a radio link control status report comprising at least one of a negative acknowledgment sequence number, the negative acknowledgment sequence number range, or the negative acknowledgment end sequence number when the plurality of consecutive radio link control missing sequence numbers exceeds the at least one negative acknowledgment sequence number range.

[0081] In a variant, when the negative acknowledgment sequence number range is exceeded, the negative acknowledgment end sequence number may follow the negative acknowledgment sequence number range in the status report.

[0082] In another variant, the negative acknowledgment sequence number may indicate a negative acknowledgment start sequence number.

[0083] In a further variant, when the negative acknowledgment sequence number range is exceeded, the negative acknowledgment end sequence number may indicate an end value of the negative acknowledgment sequence number range.

[0084] According to a second embodiment, a method may include transmitting segmented service data units comprising radio link control sequence numbers. The method may also include receiving a radio link control status report comprising at least one of a negative acknowledgment sequence number, a negative acknowledgment sequence number range, or a negative acknowledgment end sequence number when a plurality of consecutive radio link control missing sequence numbers exceeds the at least one negative acknowledgment sequence number range.

[0085] In another variant, when the negative acknowledgment sequence number range is

exceeded, the negative acknowledgment end sequence number may follow the negative acknowledgment sequence number range in the status report.

5 [0086] In a variant, when the negative acknowledgment sequence number range is exceeded, the negative acknowledgment end sequence number may indicate an end value of the negative acknowledgment sequence number range.

[0087] According to a third embodiment, a method may include receiving at least one segment of a service data unit having a sequence number. The service data unit may include at least one other segment. The method may also include determining to include a segment offset in a radio link control status report when the at least one other segment of the service data unit has not yet been received. In addition, the method may include transmitting a radio link control status report including at least one of an acknowledgement of the sequence number and the segment offset when the at least one other segment of the service data unit has not yet been received.

[0088] In a variant, a next expected packet data unit may be a segment.

15 [0089] In another variant, a timer may be started when a gap is created and the gap is created by at least one of a not yet received PDU, full SDU, or the PDU of a SDU segment. When the timer is started, the sequence number and the segment offset, which indicates an end byte of the segment or a next byte not yet received, may be recorded to be used in the status report as an acknowledgment sequence number and the segment offset, respectively.

[0090] In a variant, the method may include transmitting the radio link control status report comprising a segment offset start and a segment offset end to indicate the received at least one segment when the received at least one segment is located in a middle of the service data unit.

[0091] In a further variant, the received at least one segment may be a last segment of the service data unit.

25 [0092] In another variant, when the received at least one segment is a first segment of the service data unit, the segment offset may indicate an end byte of the received at least one segment.

[0093] According to a fourth embodiment, a method may include transmitting at least one segment of a service data unit having a sequence number, wherein the service data unit comprises at least one other segment. The method may also include receiving a radio link control status report comprising at least one of an acknowledgement of the sequence number and a segment offset when at least one other segment of the service data unit has not yet been transmitted.

30 [0094] In a variant, the method may include receiving the radio link control status report comprising a segment offset start and a segment offset end to indicate the transmitted at least one

segment when the transmitted at least one segment is located in a middle of the service data unit.

[0095] In addition, a variant may include that the transmitted at least one segment may be a last segment of the service data unit.

[0096] Further, a variant may include that when the transmitted at least one segment is a first segment  
5 of the service data unit, the segment offset may indicate an end byte of the received at least one segment.

[0097] According to a fifth embodiment, sixth embodiment, seventh embodiment, and eighth  
embodiment, an apparatus can include at least one processor and at least one memory and computer  
program code. The at least one memory and the computer program code can be configured to, with  
10 the at least one processor, cause the apparatus at least to perform a method according to the first  
embodiment, second embodiment, third embodiment, or the fourth embodiment, and any of its  
variants.

[0098] According a ninth embodiment, tenth embodiment, eleventh embodiment, and a twelfth  
embodiment, an apparatus can include means for performing the method according to the first  
15 embodiment, second embodiment, third embodiment, or fourth embodiment, and any of its variants.

[0099] According to an thirteenth embodiment, fourteenth embodiment, fifteenth embodiment,  
and sixteenth embodiment, a computer program product may encode instructions for performing a  
process including a method according to the first embodiment, second embodiment, third  
embodiment, or fourth embodiment, and any of its variants.

[0100] According to a seventeenth embodiment, eighteenth embodiment, nineteenth embodiment,  
and twentieth embodiment, a non-transitory computer-readable medium may encode instructions  
that, when executed in hardware, perform a process including a method according to the first  
embodiment, second embodiment, third embodiment, or fourth embodiment, and any of its variants.

[0101] According to a twenty first embodiment, twenty second embodiment, twenty third  
25 embodiment, and twenty fourth embodiment, a computer program code may include instructions  
for performing a method according to the first embodiment, second embodiment, third  
embodiment, or fourth embodiment, and any of its variants.

## WE CLAIM:

1. An apparatus comprising:  
at least one processor; and  
at least one memory including computer program code;  
the at least one memory and the computer program code configured to, with the at least one processor, cause the apparatus at least to:  
receive at least one segment of a service data unit having a sequence number; and,  
start a timer when a gap is created,  
wherein the gap is created by at least one of a not yet received protocol data unit, full service data unit, protocol data unit of a service data unit segment or service data unit segment.
2. An apparatus as in claim 1, wherein the service data unit comprises at least one other segment.
3. An apparatus as in claim 2, wherein the at least one memory and the computer program code configured to, with the at least one processor, cause the apparatus at least to determine to include a segment offset in a radio link control status report when the at least one other segment of the service data unit has not yet been received.
4. An apparatus as in claim 3, wherein, when the timer is started, the sequence number and the segment offset are recorded to be used in the status report as an acknowledgment sequence number and the segment offset, respectively.
5. An apparatus as in any one of claims 1 through 4, wherein the at least one memory and the computer program code configured to, with the at least one processor, cause the apparatus at least to transmit a radio link control status report.
6. An apparatus as in claim 5, wherein the radio link control status report comprising a segment offset start and a segment offset end to indicate the received at least one segment when the received at least one segment is located in a middle of the service data unit.
7. A method comprising:  
receiving at least one segment of a service data unit having a sequence number; and,  
starting a timer when a gap is created,  
wherein the gap is created by at least one of a not yet received protocol data unit, full service data unit, protocol data unit of a service data unit segment or service data unit segment.
8. A method as in claim 7, further comprising determining to include a segment offset in a radio link control status report when at least one other segment of the service data unit has not yet

been received.

9. An apparatus comprising:

at least one processor; and

at least one memory including computer program code;

the at least one memory and the computer program code configured to, with the at least one processor, cause the apparatus at least to:

determine a negative acknowledgment sequence number range, where the negative acknowledgment sequence number range comprises a plurality of consecutive radio link control missing sequence numbers;

when the plurality of consecutive radio link control missing sequence numbers exceeds the negative acknowledgment sequence number range, determine at least one negative acknowledgment end sequence number; and,

send a radio link control status report, where the radio link control status report comprises at least one of a negative acknowledgment sequence number, the negative acknowledgment sequence number range, or the at least one negative acknowledgment end sequence number.

10. An apparatus as in claim 9, wherein the at least one negative acknowledgment end sequence number follows the negative acknowledgment sequence number range in the status report, when the negative acknowledgment sequence number range is exceeded.

11. An apparatus as in claim 9 or claim 10, wherein the negative acknowledgment sequence number indicates a negative acknowledgment start sequence number.

12. An apparatus as in any one of claims 9 through 11, wherein the at least one negative acknowledgment end sequence number indicates an end value of the negative acknowledgment sequence number range, when the negative acknowledgment sequence number range is exceeded.

13. A method comprising:

determining a negative acknowledgment sequence number range, where the negative acknowledgment sequence number range comprises a plurality of consecutive radio link control missing sequence numbers;

when the plurality of consecutive radio link control missing sequence numbers exceeds the negative acknowledgment sequence number range, determining at least one negative acknowledgment end sequence number; and,

sending a radio link control status report, where the radio link control status report comprises at least one of a negative acknowledgment sequence number, the negative

acknowledgment sequence number range, or the at least one negative acknowledgment end sequence number.

14. A method as in claim 13, wherein the at least one negative acknowledgment end sequence number follows the negative acknowledgment sequence number range in the status report, when the negative acknowledgment sequence number range is exceeded.

15. A method as in claim 13 or claim 14, wherein the negative acknowledgment sequence number indicates a negative acknowledgment start sequence number.

16. A method as in any one of claims 13 through 15, wherein the at least one negative acknowledgment end sequence number indicates an end value of the negative acknowledgment sequence number range, when the negative acknowledgment sequence number range is exceeded.

17. An apparatus comprising:

at least one processor; and

at least one memory including computer program code;

the at least one memory and the computer program code configured to, with the at least one processor, cause the apparatus at least to:

transmit segmented service data units, where the segmented service data units comprise radio link control sequence numbers; and,

receive a radio link control status report, where the radio link control status report comprises at least one of a negative acknowledgment sequence number, a negative acknowledgment sequence number range, or a negative acknowledgment end sequence number, when a plurality of consecutive radio link control missing sequence numbers exceeds the at least one negative acknowledgment sequence number range.

18. An apparatus as in claim 17, wherein, when the negative acknowledgment sequence number range is exceeded, the negative acknowledgment end sequence number follows the negative acknowledgment sequence number range in the radio link control status report.

19. An apparatus as in claim 17 or claim 18, wherein, when the negative acknowledgment sequence number range is exceeded, the negative acknowledgment end sequence number indicates an end value of the negative acknowledgment sequence number range.

20. A method comprising:

transmitting segmented service data units, where the segmented service data units comprise radio link control sequence numbers; and,

receiving a radio link control status report, where the radio link control status report

comprises at least one of a negative acknowledgment sequence number, a negative acknowledgment sequence number range, or a negative acknowledgment end sequence number, when a plurality of consecutive radio link control missing sequence numbers exceeds the at least one negative acknowledgment sequence number range.

21. A method as in claim 20, wherein, when the negative acknowledgment sequence number range is exceeded, the negative acknowledgment end sequence number follows the negative acknowledgment sequence number range in the radio link control status report.

22. A method as in claim 20 or claim 21, wherein, when the negative acknowledgment sequence number range is exceeded, the negative acknowledgment end sequence number indicates an end value of the negative acknowledgment sequence number range.

23. An apparatus comprising:

at least one processor; and

at least one memory including computer program code;

the at least one memory and the computer program code configured to, with the at least one processor, cause the apparatus at least to:

receive at least one segment of a service data unit having a sequence number, where the service data unit comprises at least one other segment; and,

determine to include a segment offset in a radio link control status report, when the at least one other segment of the service data unit has not yet been received.

24. An apparatus as in claim 23, wherein the at least one memory and the computer program code configured to, with the at least one processor, cause the apparatus at least to transmit the radio link control status report, wherein the radio link control status report comprises at least one of an acknowledgement of the sequence number and the segment offset when the at least one other segment of the service data unit has not yet been received.

25. An apparatus as in claim 23, wherein the at least one memory and the computer program code configured to, with the at least one processor, cause the apparatus at least to transmit the radio link control status report, wherein the radio link control status report comprises a segment offset start and a segment offset end to indicate the received at least one segment, when the received at least one segment is located in a middle of the service data unit.

26. An apparatus as in any one of claims 23 through 25, wherein a next expected packet data unit is a segment.

27. An apparatus as in any one of claims 23 through 26, wherein a timer is started when a gap is

created by at least one of a not yet received protocol data unit, a full service data unit, or a protocol data unit of a service data unit segment.

28. An apparatus as in claim 27, wherein, when the timer is started, the sequence number and the segment offset are recorded to be used in the status report as acknowledgment sequence number and the segment offset, respectively.

29. An apparatus as in claim 28, wherein the segment offset indicates an end byte of the segment or a next byte not yet received.

30. An apparatus as in claim 23, wherein the received at least one segment comprises a last segment of the service data unit.

31. An apparatus as in claim 23, wherein, when the received at least one segment comprises a first segment of the service data unit, the segment offset indicates an end byte of the received at least one segment of the service data unit.

32. A method comprising:

receiving at least one segment of a service data unit having a sequence number, where the service data unit comprises at least one other segment; and,

determining to include a segment offset in a radio link control status report, when the at least one other segment of the service data unit has not yet been received.

33. An apparatus comprising:

at least one processor; and

at least one memory including computer program code;

the at least one memory and the computer program code configured to, with the at least one processor, cause the apparatus at least to:

transmit at least one segment of a service data unit having a sequence number, wherein the service data unit comprises at least one other segment; and,

receive a radio link control status report, wherein the radio link control status report comprises at least one of an acknowledgement of the sequence number, or a segment offset when the at least one other segment of the service data unit has not yet been transmitted.

34. An apparatus as in claim 33, wherein the radio link control status report comprises a segment offset start and a segment offset end to indicate the transmitted at least one segment, when the transmitted at least one segment is located in a middle of the service data unit.

35. An apparatus as in claim 33, wherein the transmitted at least one segment comprises a last

segment of the service data unit.

36. An apparatus as in claim 33, wherein, when the transmitted at least one segment comprises a first segment of the service data unit, the segment offset indicates an end byte of the transmitted at least one segment of the service data unit.

37. A method comprising:

transmitting at least one segment of a service data unit having a sequence number, wherein the service data unit comprises at least one other segment; and,

receiving a radio link control status report, wherein the radio link control status report comprises at least one of an acknowledgement of the sequence number, or a segment offset when the at least one other segment of the service data unit has not yet been transmitted.

38. An apparatus comprising:

means for receiving at least one segment of a service data unit having a sequence number; and,

means for starting a timer when a gap is created,

wherein the gap is created by at least one of a not yet received protocol data unit, full service data unit, protocol data unit of a service data unit segment or service data unit segment.

39. An apparatus comprising:

means for determining a negative acknowledgment sequence number range, where the negative acknowledgment sequence number range comprises a plurality of consecutive radio link control missing sequence numbers;

means for determining at least one negative acknowledgment end sequence number, when the plurality of consecutive radio link control missing sequence numbers exceeds the negative acknowledgment sequence number range; and,

means for sending a radio link control status report, where the radio link control status report comprises at least one of a negative acknowledgment sequence number, the negative acknowledgment sequence number range, or the at least one negative acknowledgment end sequence number.

40. An apparatus comprising:

means for transmitting segmented service data units, where the segmented service data units comprise radio link control sequence numbers; and,

means for receiving a radio link control status report, where the radio link control status report comprises at least one of a negative acknowledgment sequence number, a negative

acknowledgment sequence number range, or a negative acknowledgment end sequence number, when a plurality of consecutive radio link control missing sequence numbers exceeds the at least one negative acknowledgment sequence number range.

41. An apparatus comprising:

means for receiving at least one segment of a service data unit having a sequence number, where the service data unit comprises at least one other segment; and,

means for determining to include a segment offset in a radio link control status report, when the at least one other segment of the service data unit has not yet been received.

42. An apparatus comprising:

means for transmitting at least one segment of a service data unit having a sequence number, wherein the service data unit comprises at least one other segment; and,

means for receiving a radio link control status report, wherein the radio link control status report comprises at least one of an acknowledgement of the sequence number, or a segment offset when the at least one other segment of the service data unit has not yet been transmitted.

43. An apparatus comprising: means for performing a method as in any one of claims 7 through 8, or means for performing a method as in any one of claims 13 through 16, or means for performing a method as in any one of claims 20 through 22, means for performing a method as in claim 32, or means for performing a method as in claim 37.

44. A computer program comprising instructions for causing an apparatus to perform at least the following:

receiving at least one segment of a service data unit having a sequence number; and,  
starting a timer when a gap is created,

wherein the gap is created by at least one of a not yet received protocol data unit, full service data unit, protocol data unit of a service data unit segment or service data unit segment.

45. A computer program comprising instructions for causing an apparatus to perform at least the following:

determining a negative acknowledgment sequence number range, where the negative acknowledgment sequence number range comprises a plurality of consecutive radio link control missing sequence numbers;

when the plurality of consecutive radio link control missing sequence numbers exceeds the negative acknowledgment sequence number range, determining at least one negative

acknowledgment end sequence number; and,

sending a radio link control status report, where the radio link control status report comprises at least one of a negative acknowledgment sequence number, the negative acknowledgment sequence number range, or the at least one negative acknowledgment end sequence number.

46. A computer program comprising instructions for causing an apparatus to perform at least the following:

transmitting segmented service data units, where the segmented service data units comprise radio link control sequence numbers; and,

receiving a radio link control status report, where the radio link control status report comprises at least one of a negative acknowledgment sequence number, a negative acknowledgment sequence number range, or a negative acknowledgment end sequence number, when a plurality of consecutive radio link control missing sequence numbers exceeds the at least one negative acknowledgment sequence number range.

47. A computer program comprising instructions for causing an apparatus to perform at least the following:

receiving at least one segment of a service data unit having a sequence number, where the service data unit comprises at least one other segment; and,

determining to include a segment offset in a radio link control status report, when the at least one other segment of the service data unit has not yet been received.

48. A computer program comprising instructions for causing an apparatus to perform at least the following:

transmitting at least one segment of a service data unit having a sequence number, wherein the service data unit comprises at least one other segment; and,

receiving a radio link control status report, wherein the radio link control status report comprises at least one of an acknowledgement of the sequence number, or a segment offset when the at least one other segment of the service data unit has not yet been transmitted.

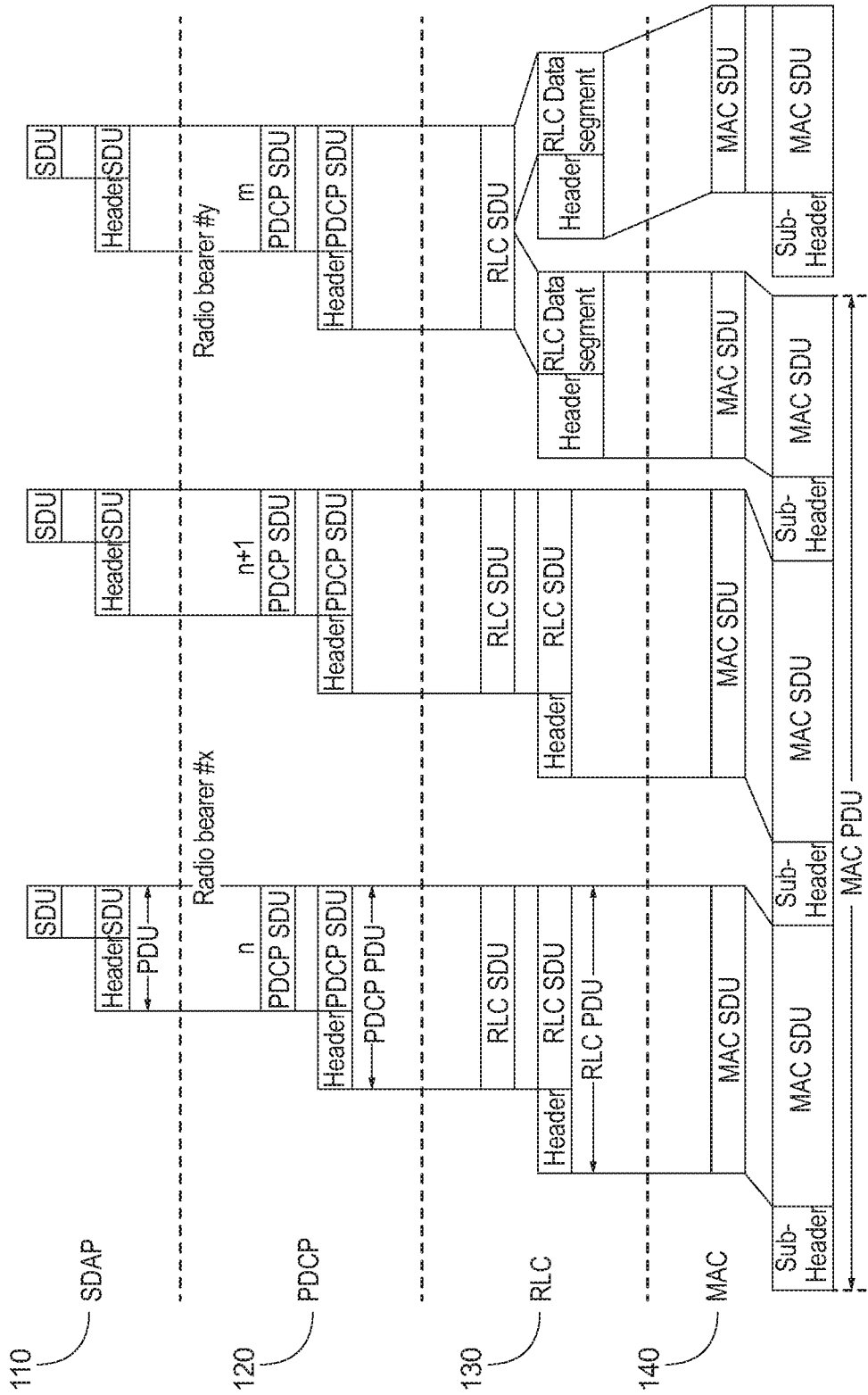

Figure 1

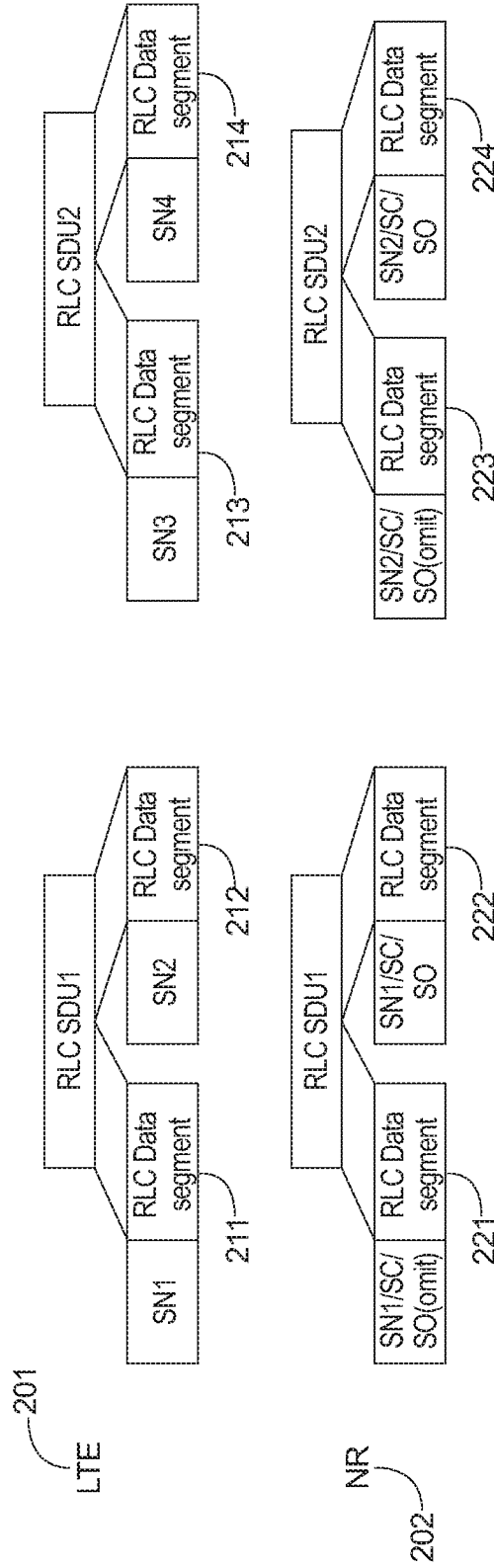

Figure 2

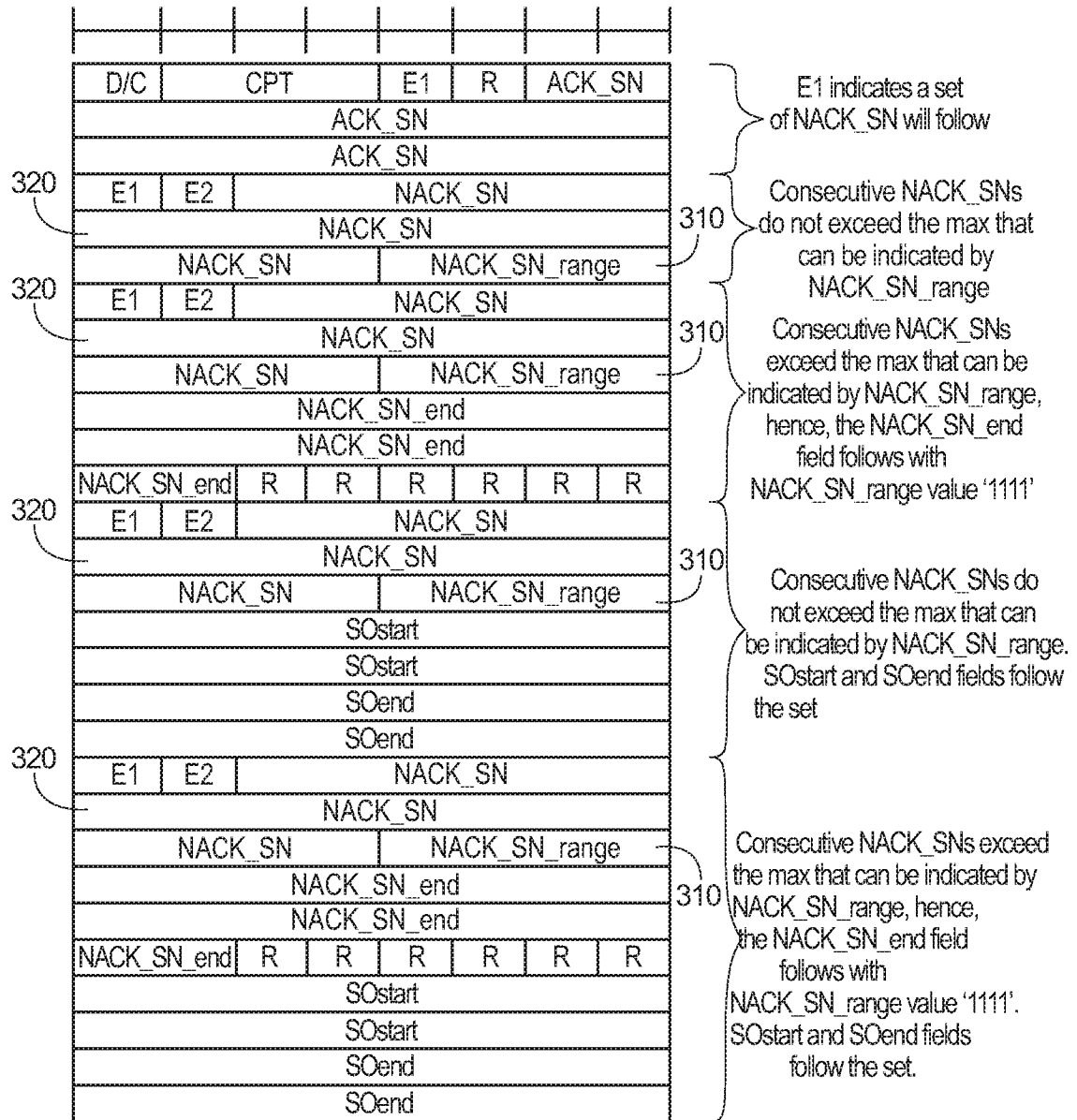

Figure 3

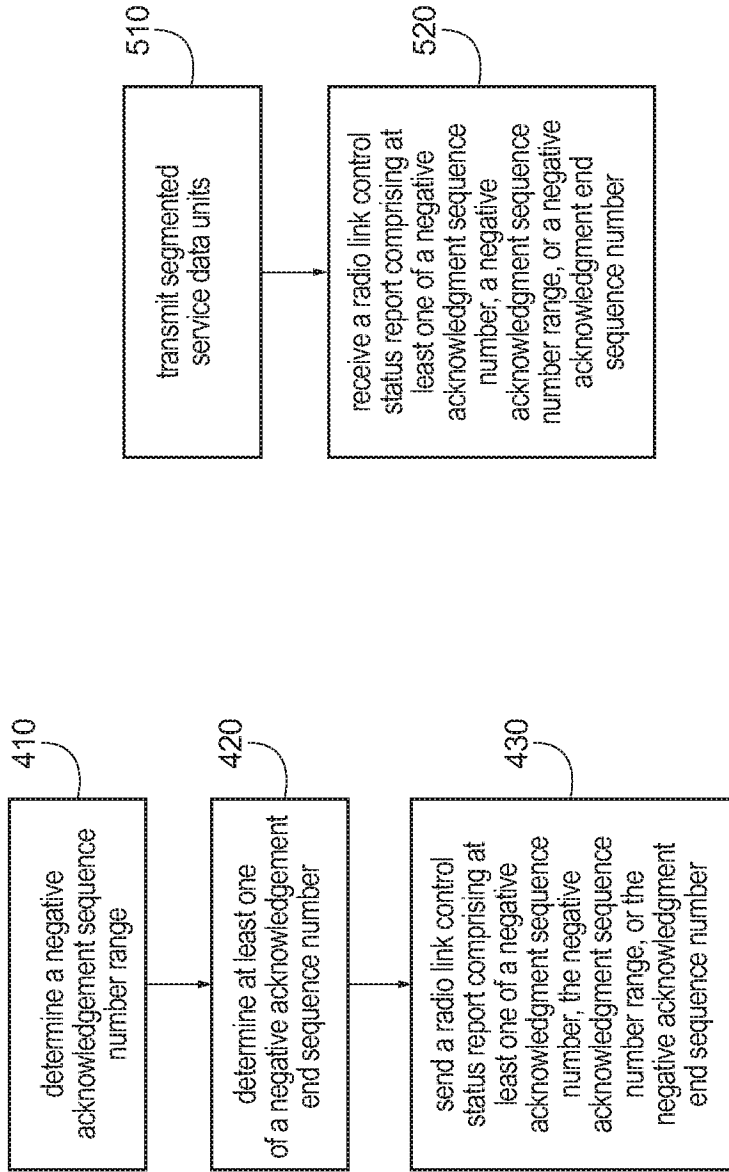

Figure 4

Figure 5

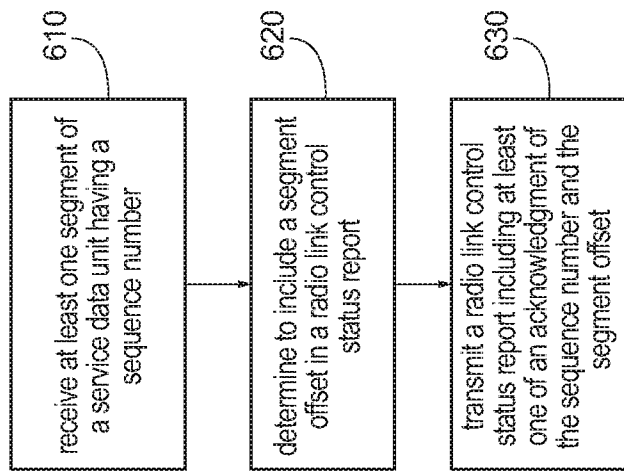

Figure 6

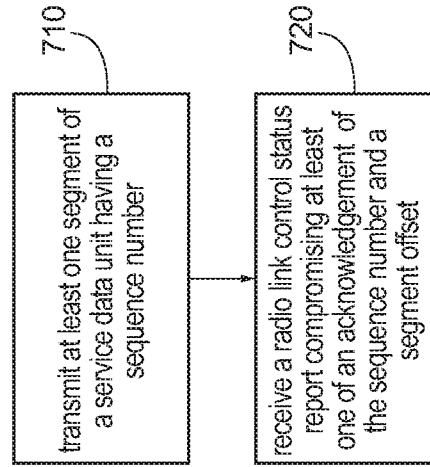

Figure 7

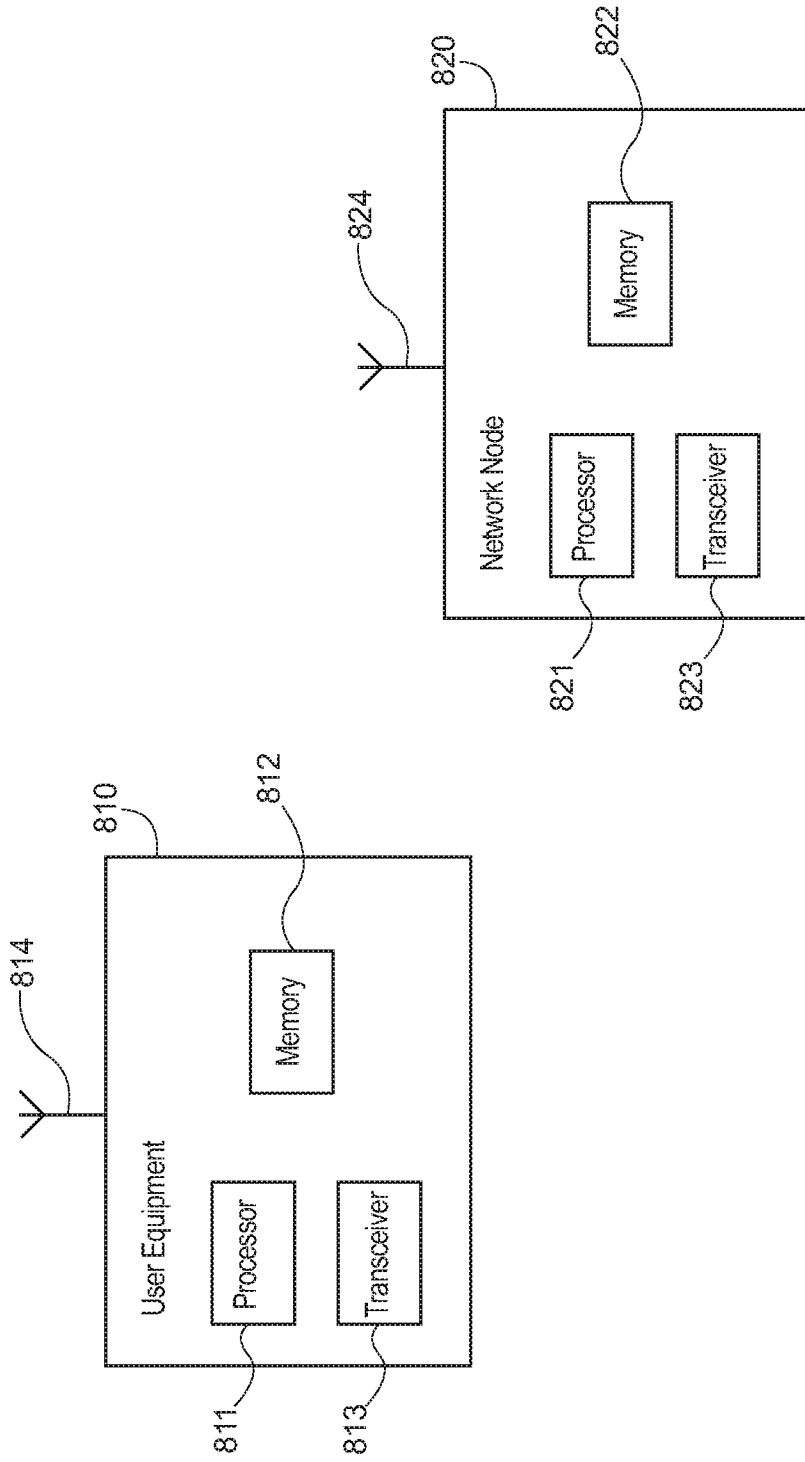

Figure 8

## INTERNATIONAL SEARCH REPORT

International application No.  
PCT/IB2018/053131

| A. CLASSIFICATION OF SUBJECT MATTER   |   |  |
|---|---|--|
| IPC: see extra sheet  |   |  |
| According to International Patent Classification (IPC) or to both national classification and IPC   |   |  |
| B. FIELDS SEARCHED  |   |  |
| Minimum documentation searched (classification system followed by classification symbols)   |   |  |
| IPC: H04L, H04W   |   |  |
| Documentation searched other than minimum documentation to the extent that such documents are included in the fields searched   |   |  |
| SE, DK, FI, NO classes as above   |   |  |
| Electronic data base consulted during the international search (name of data base and, where practicable, search terms used)  |   |  |
| EPO-Internal, PAJ, WPI data, COMPENDEX, INSPEC,   |   |  |
| C. DOCUMENTS CONSIDERED TO BE RELEVANT  |   |  |
| Category*   | Citation of document, with indication, where appropriate, of the relevant passages                          | Relevant to claim No.  |
| X   | WO 2012170724 A1 (QUALCOMM INC ET AL), 13 December 2012 (2012-12-13); paragraphs [0006]-[0037]; claims 1-11 | 1, 7, 32, 37-38, 41-44, 47-48  |
| A   | --  | 2-6, 8-31, 33-36, 39-40, 45-46   |
| A   | WO 2008070682 A2 (QUALCOMM INC ET AL), 12 June 2008 (2008-06-12); paragraphs [0009]-[0013]                  | 1-48   |
|   | --  |  |
| <input checked="" type="checkbox"/> Further documents are listed in the continuation of Box C. <input checked="" type="checkbox"/> See patent family annex.             |   |  |
| * Special categories of cited documents:  |   |  |
| "A" document defining the general state of the art which is not considered to be of particular relevance  |   | "T" later document published after the international filing date or priority date and not in conflict with the application but cited to understand the principle or theory underlying the invention  |
| "E" earlier application or patent but published on or after the international filing date   |   | "X" document of particular relevance; the claimed invention cannot be considered novel or cannot be considered to involve an inventive step when the document is taken alone   |
| "L" document which may throw doubts on priority claim(s) or which is cited to establish the publication date of another citation or other special reason (as specified) |   | "Y" document of particular relevance; the claimed invention cannot be considered to involve an inventive step when the document is combined with one or more other such documents, such combination being obvious to a person skilled in the art |
| "O" document referring to an oral disclosure, use, exhibition or other means  |   | "&" document member of the same patent family  |
| "P" document published prior to the international filing date but later than the priority date claimed  |   |  |
| Date of the actual completion of the international search   | Date of mailing of the international search report  |  |
| 05-10-2018  | 05-10-2018  |  |
| Name and mailing address of the ISA/SE<br>Patent- och registreringsverket<br>Box 5055<br>S-102 42 STOCKHOLM<br>Facsimile No. + 46 8 666 02 86                           | Authorized officer<br>Behroz Moradi<br>Telephone No. + 46 8 782 28 00                                       |  |

## INTERNATIONAL SEARCH REPORT

International application No.  
PCT/IB2018/053131

| C (Continuation). DOCUMENTS CONSIDERED TO BE RELEVANT |  |   |
|---|--|---|
| Category*   | Citation of document, with indication, where appropriate, of the relevant passages                       | Relevant to claim No.                                       |
| Y   | US 20090175206 A1 (WANG CHUNG-SHAN ET AL), 9 July 2009 (2009-07-09); paragraphs [0012]-[0055]            | 9, 13, 17, 20, 23, 33, 39-40, 45-46                         |
| A   | --   | 1-8, 10-12, 14-16, 18-19, 21-22, 24-32, 34-38, 41-44, 47-48 |
| Y   | WO 2011019427 A2 (RESEARCH IN MOTION LTD ET AL), 17 February 2011 (2011-02-17); paragraphs [0023]-[0079] | 9, 13, 17, 20, 23, 33, 39-40, 45-46                         |
| A   | --<br>-----  | 1-8, 10-12, 14-16, 18-19, 21-22, 24-32, 34-38, 41-44, 47-48 |

**Continuation of:** second sheet

**International Patent Classification (IPC)**

**H04L 1/18** (2006.01)

H04L 1/16 (2006.01)

H04W 28/06 (2009.01)

## INTERNATIONAL SEARCH REPORT

Information on patent family members

International application No.

PCT/IB2018/053131

|    |                |            |    |                 |            |
|----|----------------|------------|----|-----------------|------------|
| WO | 2012170724 A1  | 13/12/2012 | BR | 112013030817 A2 | 06/12/2016 |
|    |                |            | CA | 2838245 A1      | 13/12/2012 |
|    |                |            | CN | 103621002 A     | 05/03/2014 |
|    |                |            | EP | 2719112 A1      | 16/04/2014 |
|    |                |            | JP | 5820063 B2      | 24/11/2015 |
|    |                |            | JP | 2014520450 A    | 21/08/2014 |
|    |                |            | KR | 20140020352 A   | 18/02/2014 |
|    |                |            | KR | 101609342 B1    | 05/04/2016 |
|    |                |            | RU | 2592068 C2      | 20/07/2016 |
|    |                |            | RU | 2013158878 A    | 20/07/2015 |
|    |                |            | US | 20120314648 A1  | 13/12/2012 |
|    |                |            | US | 9294235 B2      | 22/03/2016 |
| WO | 2008070682 A2  | 12/06/2008 | BR | PI0720144 A2    | 14/10/2014 |
|    |                |            | CA | 2669309 C       | 19/03/2013 |
|    |                |            | CN | 101554008 B     | 27/03/2013 |
|    |                |            | EP | 2115926 A2      | 11/11/2009 |
|    |                |            | JP | 2010512691 A    | 22/04/2010 |
|    |                |            | JP | 4965666 B2      | 04/07/2012 |
|    |                |            | KR | 20090087118 A   | 14/08/2009 |
|    |                |            | KR | 101166610 B1    | 18/07/2012 |
|    |                |            | TW | 200833132 A     | 01/08/2008 |
|    |                |            | TW | I360970 B       | 21/03/2012 |
|    |                |            | US | 20080139113 A1  | 12/06/2008 |
|    |                |            | US | 8290428 B2      | 16/10/2012 |
| US | 20090175206 A1 | 09/07/2009 | CN | 101489252 B     | 08/09/2010 |
|    |                |            | TW | I369883 B       | 01/08/2012 |
|    |                |            | TW | 200931923 A     | 16/07/2009 |
|    |                |            | US | 8401017 B2      | 19/03/2013 |
| WO | 2011019427 A2  | 17/02/2011 | US | 20110041024 A1  | 17/02/2011 |
|    |                |            | US | 8473825 B2      | 25/06/2013 |