

(No Model.)

C. & H. BURGON.
MACHINE FOR SHEARING OR CLIPPING ANIMALS.

No. 523,880.

Patented July 31, 1894.

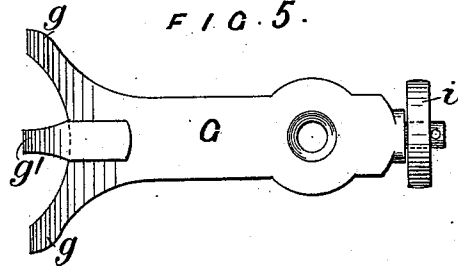
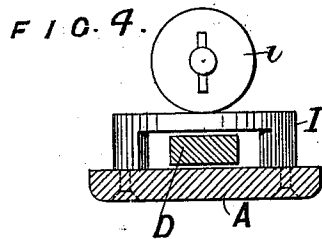
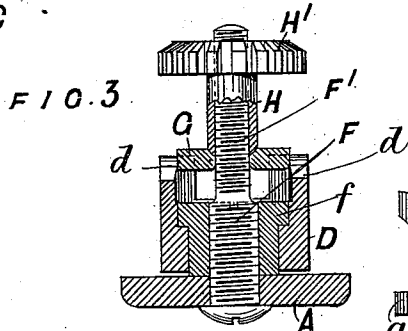
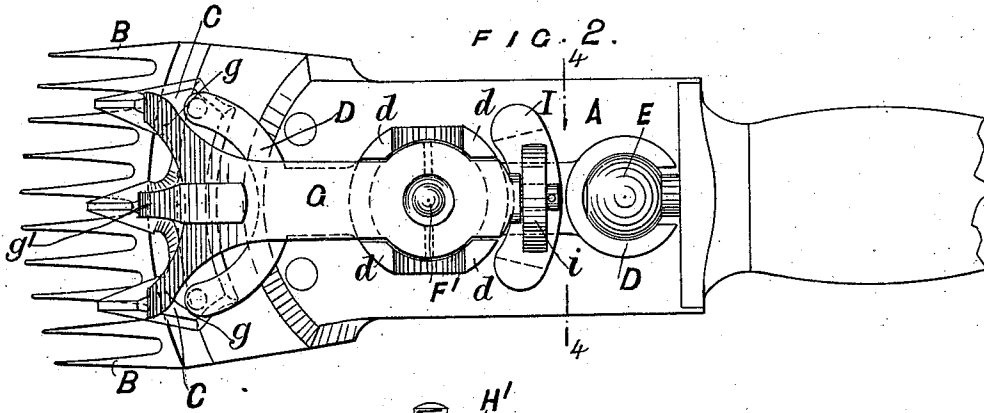
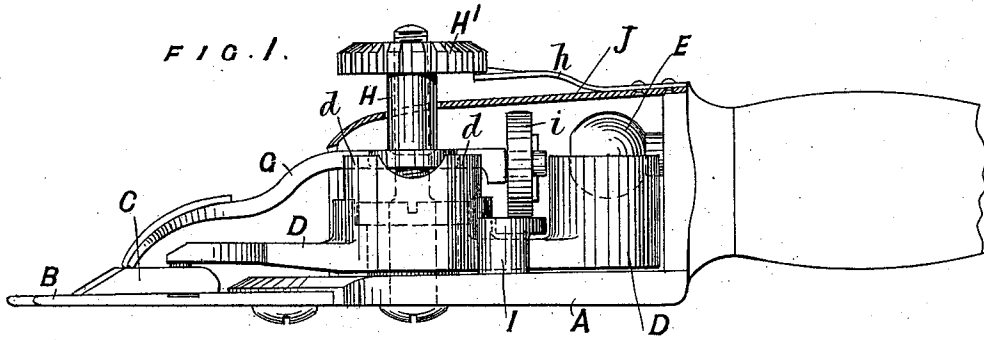

WITNESSES.
C. Sedgwick
J. Manaford

INVENTORS:
C. Burgon
BY *H. Burgon*
Munn & C
ATTORNEYS

UNITED STATES PATENT OFFICE.

CHARLES BURGON AND HARRY BURGON, OF MALIN BRIDGE, NEAR SHEFFIELD, ENGLAND.

MACHINE FOR SHEARING OR CLIPPING ANIMALS.

SPECIFICATION forming part of Letters Patent No. 523,880, dated July 31, 1894.

Application filed March 24, 1894. Serial No. 504,987. (No model.)

To all whom it may concern:

Be it known that we, CHARLES BURGON and HARRY BURGON, sheep-shear manufacturers, both of Malin Bridge, near Sheffield, in the county of York, England, have invented new and useful Improvements in Machines for Shearing or Clipping Animals, of which the following is a full, clear, and exact description.

This invention relates to improvements in machines for shearing and clipping animals, and has for its object to relieve the part of the mechanism by which reciprocating motion is imparted to the cutters of the duty of transmitting to the cutters the pressure necessary to insure the cutting action. Heretofore the pressure has usually been transmitted through the oscillating cutter driving lever with the result that the pivotal axis and bearing surfaces of said lever have been exposed to considerable friction and wear in consequence of the high speed at which such machines are run, and the rough usage to which they are subjected. By the present improvement the durability of the mechanism and the ease of running of the machine are greatly increased and the power necessary to drive it proportionally diminished. The desired results are accomplished by the construction of the machine hereinafter described with reference to the accompanying drawings, forming part of this specification, and wherein—

Figure 1 is a longitudinal elevation of the machine the casing being in section. Fig. 2 is a plan of the same with the casing removed. Fig. 3 is a cross section through the pivotal axis of the cutter driving and pressure levers. Fig. 4 is a cross section on line 4—4 of Fig. 2, showing the roller bearing and path of the pressure lever. Fig. 5 is a plan of the pressure lever separately.

The same letters of reference indicate corresponding parts in all the figures.

A is the frame, B the comb or bed cutter plate, C the top cutters, D the cutter-driving lever, E the crank pin upon the driving shaft, engaging the forked rear end of the lever D, all as usual. The oscillating cutter-driving lever D works upon a pivot fixed directly to the frame A of the machine and it takes no

part whatever in applying pressure to the cutters C but merely causes them to reciprocate to and fro over the comb plate B, this lever D being forked at its front end and engaged with the reciprocating cutters C, by means of lugs, received in holes in the cutter plate in the usual manner. The pivot of the lever D is formed of a threaded stud F and a cylindrical steel nut or sleeve *f* screwed thereon, the stud F being screwed through a tapped hole in the base plate of the frame A and the cylindrical steel nut or sleeve *f*, being received in the boss of the lever D and forming the wearing surface of the pivot. This nut or sleeve screws upon the pin F until its lower end jams hard down upon the base plate A, and it has a flat head counter-sunk in the boss of the lever D, whereby the lever is retained on its pivot.

The lever D is free to oscillate with very slight friction since there is no upward thrust of the lever against the head of the sleeve or nut.

The pressure necessary to maintain the reciprocating cutters C in operative contact with the comb or bed cutters B is transmitted by a separate lever G pivoted about the same vertical axis as the cutter-driving lever, D, the two levers being loosely connected by the extended boss of lever D, said boss being notched to receive the arms of lever G and leave studs *d* which embrace said arms and cause the pressure lever G to oscillate with the cutter driving lever D. The pressure lever G has an upward bearing against a fulcrum or abutment H, and to enable the pressure to be regulated the abutment H is formed of a nut or sleeve screwing on a threaded prolongation F' of the stud F. The bearing surfaces of the abutment H and lever G are hemispherical so as to form a sort of ball and socket joint as shown and the lever G is sufficiently loose on the pin F' to admit of said lever oscillating in a transverse plane upon this ball and socket bearing to the minute extent necessary, to allow it to accommodate itself to the slightly hollowed face of the comb plate B and maintain an even pressure upon the top cutters C at all points of their stroke. The head H' of the nut or sleeve is notched

and retained in position after being adjusted by a detent spring *h* fixed to the casing *J*. The front end of this pressure lever *G* is forked and bears upon the cutters by two rigid prongs *g*, *g* one near each end of the cutter plate *C* and by a middle prong *g'* which is a stiff spring riveted or screwed to the lever *G* and capable of transmitting its proper share of the pressure, but of yielding sufficiently to insure an equal distribution of the pressure between the three prongs *g*, *g'*, *g*. The rear end of the pressure lever *G* is furnished with an anti-friction roller *i* which bears on a steel race-plate *I* fixed to the frame *A*, and bridging over the tail end of the lever *D* which plays beneath.

Having now particularly described and ascertained the nature of our said invention and in what manner the same is to be performed, we declare that what we claim is—

1. In a shearing or clipping machine, the combination with the oscillating cutter driving lever whereby motion only is transmitted to the cutters, of a pressure lever whereby pressure only is transmitted to the cutters, said pressure lever being loosely connected to the cutter driving lever so as to oscillate with it about the same axis, and having an upward bearing against an abutment co-axial with the center of oscillation, a downward bearing upon the cutter, and a downward moving bearing at its rear end upon the machine frame as specified.

2. In a shearing or clipping machine, the combination with the oscillating cutter-driving lever whereby motion only is transmitted to the cutters, of a pressure lever loosely connected to the cutter driving lever so as to oscillate with it about the same vertical axis, said pressure lever having an upward bearing against an abutment co-axial with the center of oscillation, a downward bearing upon the cutter and a downward laterally-rolling bearing upon a race plate bridging over the tail end of the cutter driving lever as specified.

3. In a shearing or clipping machine, the combination with the oscillating cutter-driving lever whereby motion only is transmitted to the cutters, of a pressure lever loosely connected to the cutter-driving lever so as to oscillate with it about the same vertical axis, said pressure lever having a ball and socket bearing against a nut or sleeve screwing on the driving lever axis, the pressure lever bearing upon the cutter at its front end and having a rolling bearing at its rear end upon the machine frame as specified.

4. In a shearing or clipping machine, the combination with the oscillating cutter driving lever whereby motion only is transmitted to the cutters, of a pressure lever loosely connected with the cutter driving lever so as to oscillate with it about the same vertical axis said pressure lever having an upward ball and socket bearing against an abutment co-axial with the driving lever axis and having a roller bearing at its rear end upon the machine frame and at its front end a central spring prong between two rigid prongs, all three prongs taking a downward bearing on the cutter as specified.

5. In a shearing or clipping machine, the combination with a fixed cutter, a movable cutter, and a driving lever for vibrating the latter, of the pressure lever, pivoted on the axis of said driving lever, and bearing at its front end on the movable cutter, and means for loosely connecting the two levers on either side of their common axis, as shown and described.

Signed by the said CHARLES BURGON and by the said HARRY BURGON.

CHARLES BURGON.
HARRY BURGON.

In presence of—

HARRIET MORTIMER,
HANNAH WARHURST,
*Both of Fern Bank, Wisewood, nr. Sheffield,
Domestic Servants.*