

[72] Inventors **Hans Leo Ditscheid**
Bergisch-Gladbach;
Walter Scherrer, Cologne-Mulheim, both
of, Germany

[21] Appl. No. **761,678**

[22] Filed **Sept. 23, 1968**

[45] Patented **Aug. 17, 1971**

[73] Assignee **Felten & Guillaume Carlswerk**
Aktiengesellschaft
Cologne-Mulheim, Germany

[32] Priority **Oct. 6, 1967**

[33] **Germany**

[31] **P 16 40 104.0**

2,825,874 3/1958 Kandoian 333/22 (F)

3,106,600 10/1963 Crosby 174/15 (C)

3,121,204 2/1964 Giordano 333/22

3,292,016 12/1966 Kafka 174/15 (C) X

FOREIGN PATENTS

826,939 1/1952 Germany 174/15 (C)

491,794 9/1938 Great Britain 333/22

OTHER REFERENCES

Andrew, Page R4 of Catalog "R," Andrew Corp. P.O. Box 807, Chicago, Ill.

Primary Examiner—Herman Karl Saalbach
 Assistant Examiner—Wm. H. Punter
 Attorney—Michael S. Striker

[54] **TERMINAL ASSEMBLY FOR THE END PORTION OF A FLUID-COOLED COAXIAL CABLE**
 8 Claims, 5 Drawing Figs.

[52] U.S. Cl. 333/33,
 333/34, 333/22 F, 333/96, 174/15 C

[51] Int. Cl. H01b 7/34,
 H01p 1/26, H03p 13/00

[50] Field of Search 333/22, 22
 F, 96, 34, 35, 33, 99; 174/15 C, 16; 315/50

[56] **References Cited**

UNITED STATES PATENTS

2,031,975 2/1936 Northrup 174/15 (C)

2,432,093 12/1947 Fox 333/35 X

2,453,759 11/1948 Robinson 333/34

2,652,544 9/1953 Muchmore 333/35 X

ABSTRACT: A cable terminal assembly to be secured to an end portion of a high frequency cable of the type having an outer and a coaxial tubular fluidtight inner conductor through which a cooling fluid is to be circulated. Conductor means is provided on the assembly which extends radially of the outer and inner conductors of the cable when the assembly is secured to the end portion thereof, and which is arranged to be electrically conductively connected with the inner conductor of the cable. Conduit means is arranged to be axially connected with the inner conductor of the cable so as to supply fluid to or receive fluid from the inner conductor. Shielding means serves to shield both the surroundings of the cable terminal and also cooling fluid flowing in the conduit means from the electromagnetic field created about the terminal when the cable transmits high frequency energy.

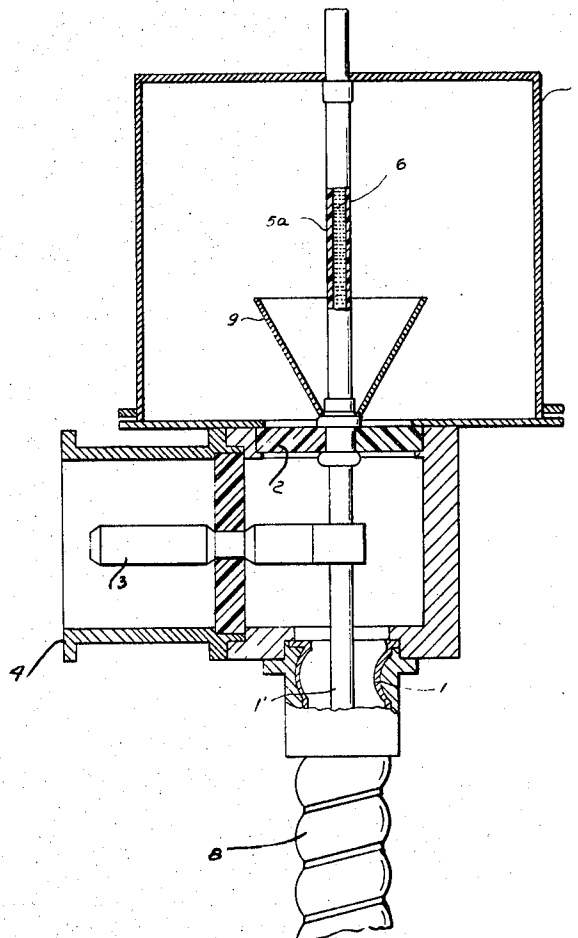
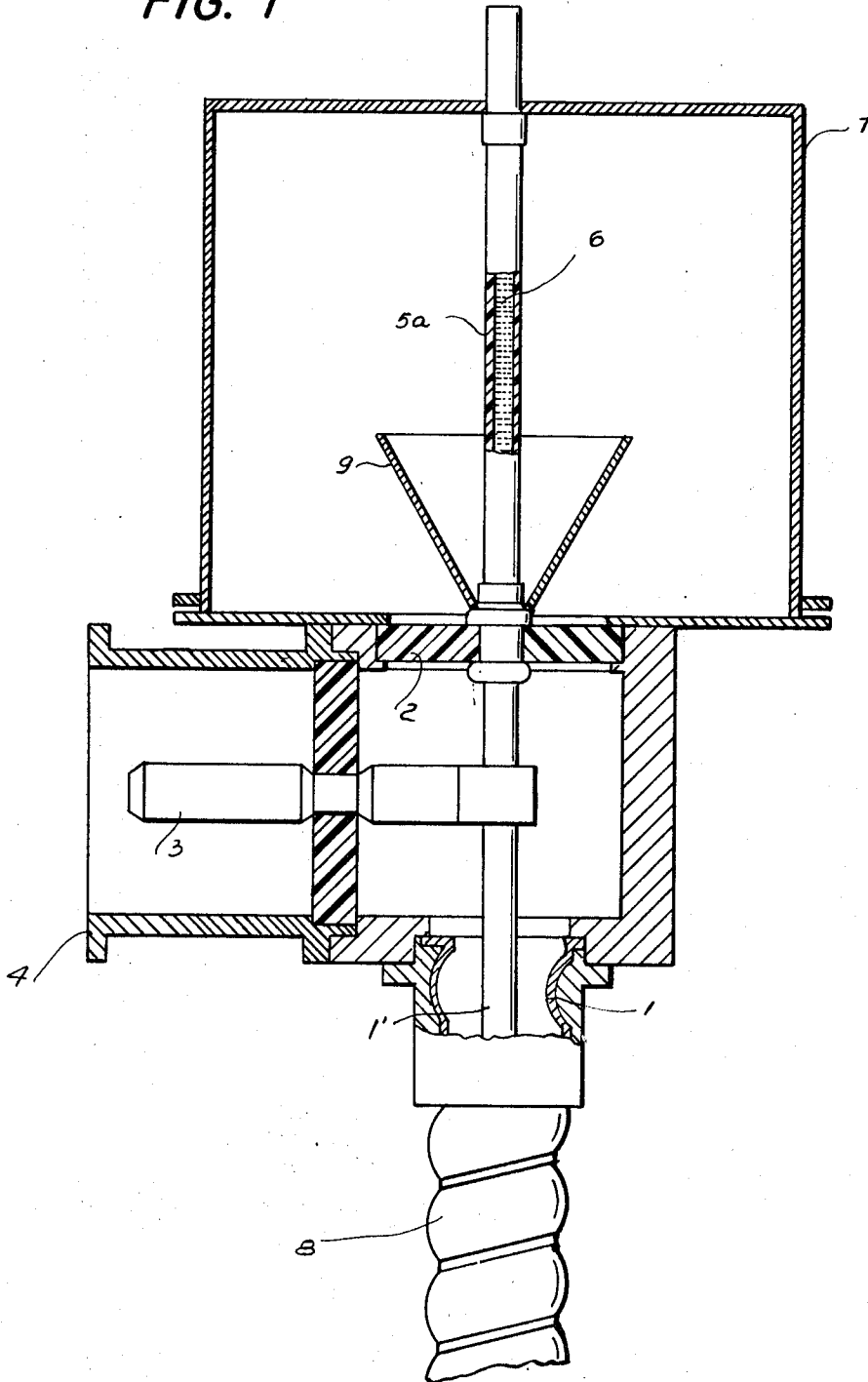

FIG. 1



INVENTOR
HANS-LEO DITSCHERD
WALTER SCHERRER
BY
Michael S. Straker
ATTORNEY

FIG. 2

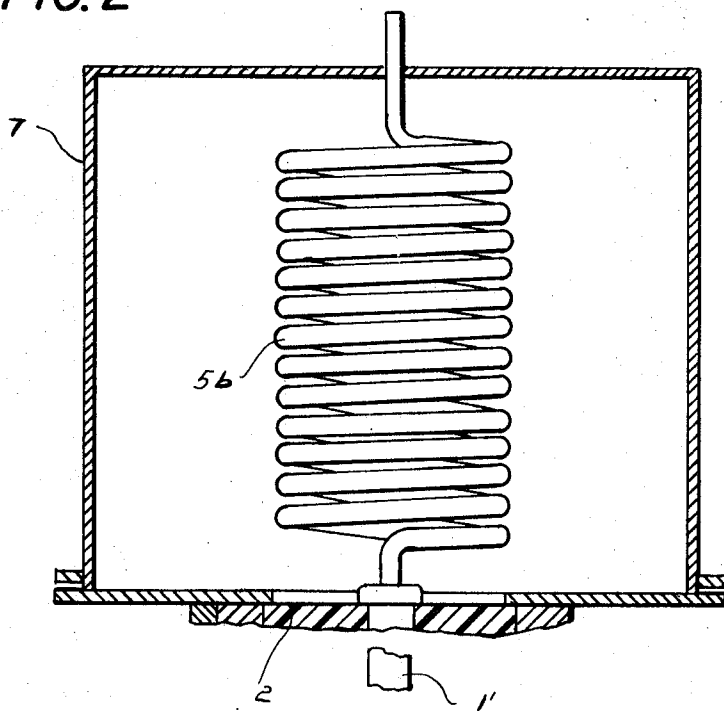
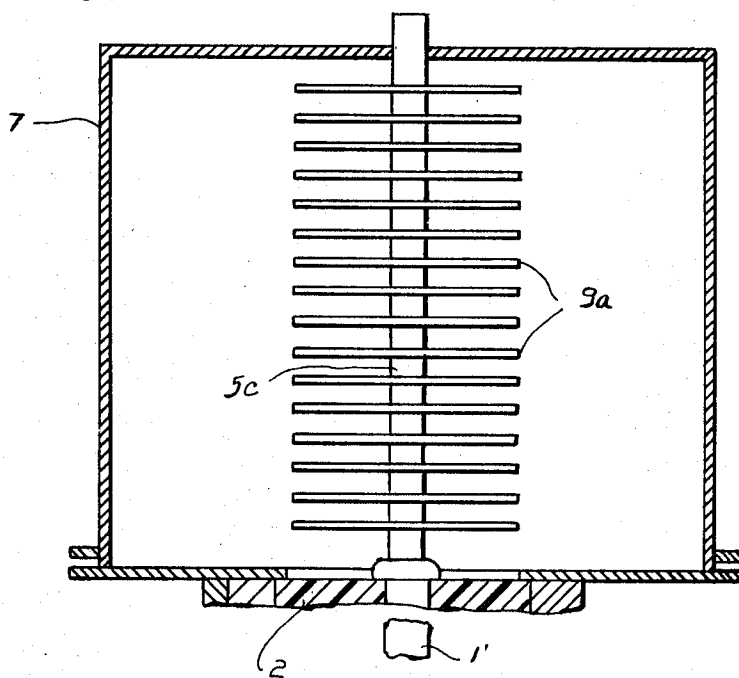

FIG. 3



INVENTOR
HANS-LEO DITTELHEID
BY WALTER SCHERRER
MORDELL S. STRIKER
ATTORNEY

FIG. 4

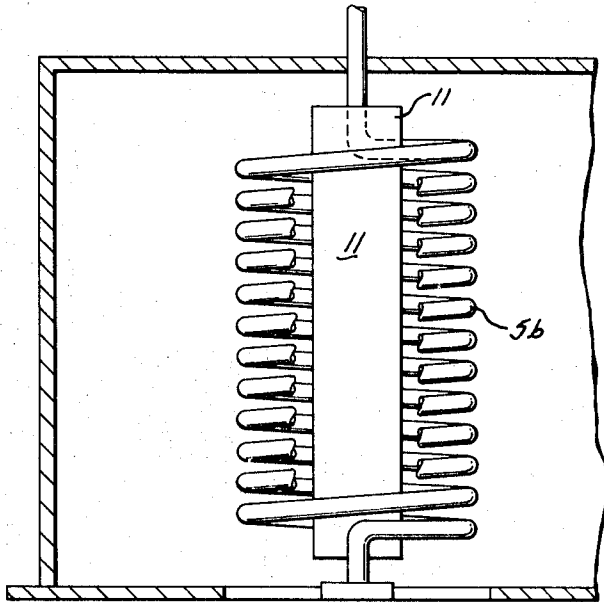
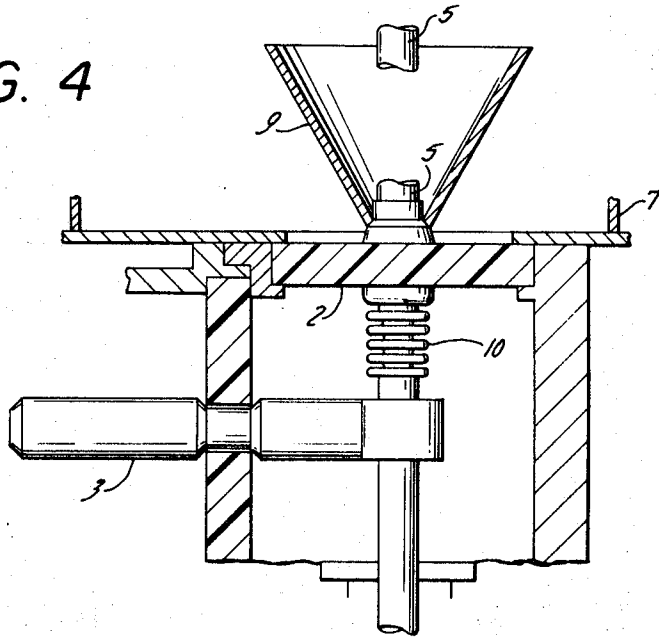

FIG. 5

INVENTOR
HANS-LEO DITTSCHNEID
BY *WALTER SCHROEDER*
Karl J. Thal.
ATTORNEY

TERMINAL ASSEMBLY FOR THE END PORTION OF A FLUID-COOLED COAXIAL CABLE

BACKGROUND OF THE INVENTION

The present invention relates to coaxial high frequency cables generally, and more particularly to cable terminal assemblies for use with such cables. Still more specifically the present invention relates to cable terminal assemblies for use with coaxial high frequency cables of the type in which the inner conductor is cooled with a cooling fluid.

It is well known that where electrical high frequency energy is to be transmitted through symmetrical ro coaxial cables, resistance losses occur in the metallic conductors which with a given current are the higher, the lower the conductor cross section which carries the energy. With increasing frequency the electrical energy will flow at the surface of the conductor in an ever thinner layer, a phenomenon which is known in the art as the "skin effect." As a result of this the resistance losses depend upon the circumference of the conductor so that in the case of coaxial cables the largest resistance losses occur at the inner conductor. The developing heat resulting from these resistance losses must be transmitted through the dielectric to the outer conductor of the cable and must be radiated thereby or otherwise suitably withdrawn therefrom.

On the one hand, the insulating materials customarily used require that the inner conductor not exceed a temperature of between substantially 100° and 160° C. On the other hand, technical developments call for the transmission of ever higher energies. In the case of coaxial high frequency cables this has resulted in dimensions which can not be further increased within the framework of economic possibilities.

One solution which is known is to construct the inner conductor of a coaxial cable of the type in question as a fluidtight pressure-resistant conduit through which a cooling fluid is circulated which serves to directly exchange heat with the conduit and remove the heat resulting from resistance losses. With this construction the transmittable energy has been increased to such an extent that the limit of transmittable energy is now dictated no longer by resistance losses and the resulting temperature increase of the cable, but only by the dielectric strength of the cable. Because the cooling fluid flows in the field-free space of the interior of the inner tubular conductor, the electrical characteristics of the cables are not influenced by the presence of the cooling fluid.

Coaxial cables of this type are provided with terminal assemblies, that is arrangements which close the ends of the cable. One of the functions of these terminal assemblies is to assure that the cooling fluid supplied to the inner conductor of the cable is supplied to and removed from the inner conductor in such a manner that the losses of high frequency energy which occurs in the region of the cable end portion, that is of the terminal assembly, are maintained to a minimal level. An attempt at meeting this requirement already exists in the art wherein the cooling fluid is supplied at the end of the coaxial cable in radial direction through the electromagnetic field of the cable to the inner conductor, or, depending upon whether the assembly is located at the upstream end or the downstream end of the cable, to remove the cooling fluid in the same manner. The conduit for supplying and/or removing the cooling fluid consists of insulating material in this known construction. However, it has been found that this construction is not satisfactory because the cooling fluid must pass through a region of high field density and, furthermore, in this construction the fluid which is usually a liquid has low water column pressure. This leads to unacceptable energy losses, especially if the cooling fluid is water, combined with an increased rise in temperature of the cooling fluid. Additionally there is the disadvantageous fact that radial supply and/or removal of the cooling fluid is not only relatively difficult to achieve and requires expensive technical measures, but also does not represent a good solution from the point of view of the dynamics of fluid flow.

Accordingly, it is a general object of the present invention to overcome these disadvantages.

A more particular object of the invention is to provide a cable terminal assembly of the type under discussion which is not possessed of these disadvantages.

Still more specifically, it is an object of the invention to provide such a cable terminal assembly wherein the cooling fluid is supplied and/or removed under advantageous flow conditions.

A concomitant object of the invention is to provide such a cable terminal assembly wherein the high frequency energy losses in the region of the terminal assembly are reduced to a minimum.

Still another object of the invention is to provide such a terminal assembly wherein the danger of cross modulation, particularly in the region of short and ultrashortwaves, is also maintained at a minimum impossible level.

SUMMARY OF THE INVENTION

In accordance with the above objects, and others which will become apparent hereafter, one feature of our invention resides in the provision of a cable terminal assembly for use with a high frequency cable of the type having an outer and a coaxial tubular fluidtight inner conductor through which a cooling fluid is to be circulated. The cable terminal assembly will in known manner be secured to an end portion of the cable and comprises, in accordance with our invention, conductor means which extends radially of the inner and outer conductor of the cable when the assembly is secured to the latter, and which conductor means is arranged so that it is in the secured condition of the terminal assembly in electrically conductive contact with the inner conductor of the cable. Conduit means is provided for passage of the cooling fluid therethrough and communicates with the inner conductor of the cable, constituting an axial fluid-conducting extension thereof so that fluid may be supplied to or removed from the inner conductor, depending on whether the assembly is provided at the upstream of downstream end of the cable, axially of the inner conductor. In the region of the junction between the cooling-fluid conduit means and the inner tubular conductor of the cable, the electromagnetic field of the cable terminal is shielded off by suitable shielding means with respect both to the ambient regions and to the cooling fluid.

The novel features which are considered as characteristic for the invention are set forth in particular in the appended claims. The invention itself, however, both as to its construction and its method of operation, together with additional objects and advantages thereof, will be best understood from the following description of specific embodiments when read in connection with the accompanying drawings.

BRIEF DESCRIPTION OF THE DRAWING

FIG. 1 is a somewhat diagrammatic view, partly sectioned and partly broken away, of an end portion of a coaxial cable with a terminal assembly according to one embodiment of the invention connected thereto;

FIG. 2 is a view somewhat similar to that of FIG. 1, but with certain portions thereof omitted as not required for an understanding of FIG. 2, of a further embodiment of the invention;

FIG. 3 is a view similar to FIG. 2 but illustrating yet an additional embodiment of the invention;

FIG. 4 is analogous to FIG. 1, showing another embodiment;

FIG. 5 is analogous to FIG. 2, also showing a further embodiment.

DESCRIPTION OF THE PREFERRED EMBODIMENTS

Discussing now the drawing in detail, and firstly FIG. 1 thereof, it will be seen that we have illustrated an end portion of a coaxial cable which comprises an outer conductor 1 and a tubular fluidtight inner conductor 1'. Through the latter a

cooling fluid is to be circulated so as to cool the inner conductor 1'.

The cable terminal assembly according to our present invention is secured to the end portion of the coaxial cable by having the end portion of the inner conductor 1' extend through a housing 4 of the assembly, this end portion being secured and maintained in place by a disc 2 of insulating material. How this is accomplished is of no consequence for the purposes of the present invention.

A suitable conductor means is provided as part of the assembly, here identified as a conductive element 3 which extends radially of the conductors 1 and 1' but is in electrically conductive connection only with the inner conductor 1'. Depending on whether the assembly is located at the upstream end of the cable or at the downstream end, the element 3 may serve to supply electrical energy to the inner conductor 1' or to receive it from the same. In either case, however, the supply or removal of electrical energy is accomplished in radial direction of the cable.

The supply and removal of cooling fluid 6, here assumed to be water, is accomplished in axial direction of the cable, however. For this purpose in the embodiment of FIG. 1 there is provided a conduit 5a consisting of electrically insulating material which is in communication with the interior of the pressure and fluidtight tubular inner conductor 1' of the cable. The necessary connection between the conductor 1' and the conduit 5a can be effected in known manner. Shielding means is provided which, in the embodiment of FIG. 1, includes a flaring or funnel-shaped member 9 of metallic material which surrounds the juncture of the conduit 5a and the inner conductor 1', with its wide open end facing away from the cable, and which is in electrically conductive contact with the inner conductor 1'. This member 9 serves to largely shield the cooling liquid 6 passing through the conduit 5a, either into or out of the inner conductor 1' from the electromagnetic field of the cable. There is further provided additional shielding means in form of a shielding member 7 of substantially cylindrical cross sectional configuration which surrounds the conduit 5a and the shielding member 9 with large spacing; the member 7 is also of metallic material and is conductively connected with the outer conductor 1 of the cable 8. It serves to shield the field space of the cable 8 against the ambient space.

By properly selecting the diameter of the member 7, the length of the conduit 5a and the configuration of the member 9 the energy losses which occur in the coupling region of the cooling liquid, that is in the region where coupling is effected between the conduit 5a and the inner conductor 1', can be reduced to a minimum.

In the embodiment of FIG. 2 certain portions illustrated in FIG. 1 have been omitted. It is to be understood that these portions are the same as in FIG. 1 and are therefore not required to be illustrated for a proper understanding of the invention.

The embodiment of FIG. 2 differs from that of FIG. 1 in that the conduit 5b which serves to supply or receive cooling fluid is here configured as a coil of substantially cylindrical configuration and consists of metallic material. This coil constitutes the internal conductor of a high-ohmic coaxial delay line which is unilaterally shorted, that is shorted at that point where it extends through and contacts the outer shielding member 7. The latter constitutes the exterior conductor of the delay line.

As shown in FIG. 5, the embodiment of FIG. 2 may be further developed by providing it with a ferrite core 11 which may be located within the confines of the convolutions of the coil constituted by the metallic conduit 5b.

The embodiment of FIG. 3, finally, again utilizes a straight conduit 5c which also consists of metallic material and which carries at its exterior extending transversely of its elongation a plurality of axially spaced metallic discs 9a. Such a construction is also known from delay lines and it is to be understood that in FIG. 3, just as in FIG. 2, the conduit 5c with the discs 9a carried thereon constitute with the shielding member 7 a

coaxial high-ohmic delay line which is again shorted at the point at which the conduit 5c extends through and contacts the member 7.

The advantages of the present invention will be understood if it is considered that the water column in the terminal assembly according to the present invention may be selected of sufficient height, and that it is shielded against the electromagnetic field of the cable, which latter is further shielded against ambient influences. This makes it possible to reduce the energy losses in the region of the terminal assembly to a minimum, which is particularly advantageous if water is used as the cooling fluid. Of course, an additional advantage is the great simplicity of the construction according to the present invention.

It will of course be appreciated that it may be necessary to compensate for length changes occurring between the inner conductor 1' and the conduit 5a of FIG. 1 which consists of a different material than the conductor 1', namely electrically insulating material, which changes may result from temperature fluctuations. To accommodate such changes contractable and expandable tubular metallic section such as an elastic metallic tubular member may be interposed between the conduit 5a and the conductor 1' in the embodiment of FIG. 1, in communication with both of them. Advantageously, a corrugated tube section of red brass may be used for this purpose, although this is not the only possibility as will obviously be appreciated. This is shown in FIG. 4 where the metallic section is designated with reference numeral 10.

As far as the embodiments of FIGS. 2 and 3 are concerned it will be understood that they make it possible to utilize a cooling fluid which need not have particularly good electrical qualities, such as water. The embodiment of FIG. 3 is somewhat more advantageous than that of FIG. 2 because it permits unhindered straight line flow of liquid in the conduit 5c contrary to what is the case in FIG. 2 where the conduit 5b is convoluted as shown.

Particular advantages of the embodiments of FIGS. 2 and 3 are to be seen in the fact that the cooling liquid is completely shielded from the electromagnetic field of the cable because the respective conduit consists of metallic material, so that high frequency energy losses in the cooling liquid are completely avoided which makes the use of water or a similar liquid possible. On the other hand, the member 7 constituting the exterior conductor of the delay line which consists of the member 7 and the member 5b in FIG. 2, and the member 7 and the member 5c with its discs 9a in the embodiment of FIG. 3, serves to completely shield the field space of the cable against ambient influences and against the ambient space, so that energy radiation to the ambient space is entirely precluded. By suitably dimensioning the thus-obtained delay line in FIGS. 2 or 3 it is possible to assure that the reflection factor resulting from the coupling organs remains below 5 percent even if the transmission range is greater than 2 octaves at the band ends. A further reduction in the reflection factor can be obtained if, in accordance with an additional concept according to the present invention, the reflection factor caused by the delay line constituted in the embodiment of FIGS. 2 and 3 and acting as will be appreciated as a parallel resonant circuit in either case, is compensated on a broadband basis in the high frequency energy cable by a series resonant circuit consisting of concentrated circuit elements, and is placed as inner conductor of the coaxial coupling.

Without further analysis, the foregoing will so fully reveal the gist of the present invention that others can be applying current knowledge readily adapt it for various applications without omitting features that, from the standpoint of prior art, fairly constitute essential characteristics of the generic or specific aspects of this invention and, therefore, such adaptations should and are intended to be comprehended within the meaning and range of equivalence of the following claims.

What we claim as new and desire to be protected by Letters Patent is set forth in the appended claims.

1. For use with a high frequency cable of the type having an outer and a coaxial tubular fluidtight inner conductor adapted

5

6

for circulation of a cooling fluid therethrough, a cable terminal assembly to be secured to an end portion of the cable and comprising conductor means extending radially of said conductors when said assembly is secured to the cable and arranged to be in electrically conductive contact with said inner conductor; conduit means for passage of the cooling fluid therethrough, said conduit means communicating with and constituting an axial fluid-conducting extension of said inner conductor when said assembly is secured to the cable; and shielding means shielding the ambient regions of said assembly, as well as cooling fluid in said conduit means, from the electromagnetic field which is generated when the cable transmits high frequency energy.

2. A terminal assembly as defined in claim 1 said conduit means consisting of an electrically insulating material; and wherein said shielding means comprises a flaring first metallic shielding member surrounding said conduit means in the region of the juncture thereof with said inner conductor and having a narrow end portion conductively connected with said inner conductor, and a second metallic shielding member surrounding said first member and said juncture with spacing and being conductively connected with said outer conductor.

3. A terminal assembly as defined in claim 2, said first shielding member being of substantially funnel-shaped configuration, and said second shielding member being of substantially cylindrical configuration.

4. A terminal assembly as defined in claim 2; further comprising a contractable and expansible tubular metallic section interposed between and communicating with said inner conductor and said conduit means for compensating variations in the length of said inner conductor resulting from thermal fluctuations.

5. A terminal assembly as defined in claim 1, said shielding means comprising a metallic shielding member surrounding the region of the juncture between said conduit means and said inner conductor, and said conduit means consisting of metallic material, said shielding means and said conduit means being constructed and cooperating in the manner of a high-ohmic unilaterally shorted coaxial delay line with said conduit means constituting an internal conductor for the delay line.

6. A terminal assembly as defined in claim 5, said conduit means being configured as a cylindrical coil.

7. A terminal assembly as defined in claim 6; and further comprising a ferrite core provided within the confines of the cylindrical coil constituted by said conduit means.

8. A terminal assembly as defined in claim 5, said conduit means including a straight conduit and comprising a plurality of coaxial metallic discs axially spaced from one another and extending transversely of the elongation of said tubular conduit surrounding and mounted on the same.

30

35

40

45

50

55

60

65

70

75