

H. B. MALLORY.
HAT TIP CLIPPING MACHINE.
APPLICATION FILED MAR. 11, 1910.

998,191.

Patented July 18, 1911.

3 SHEETS—SHEET 1.

Fig. 1.

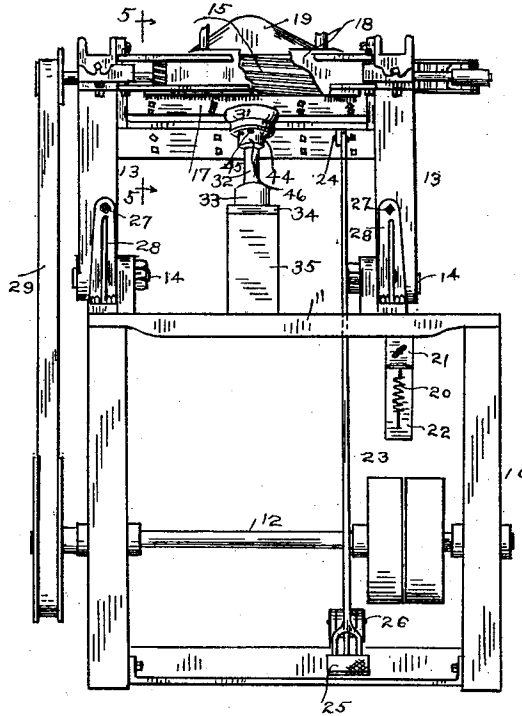
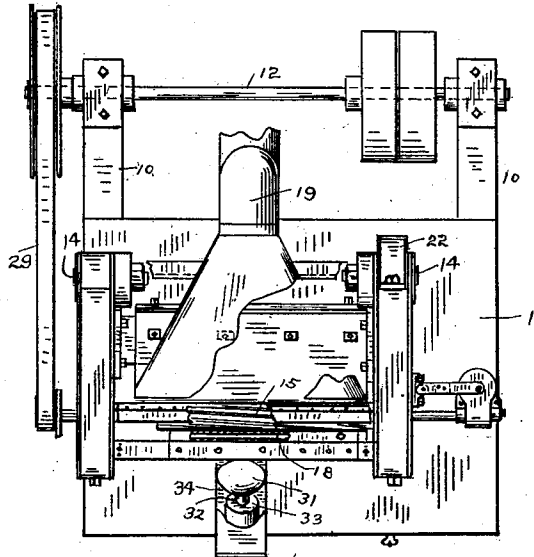

Fig. 2.



WITNESSES:

*Ernst P. Wold,
S. W. Aikerton.*

INVENTOR

Harry B. Mallory

BY *A. M. Wooster*
ATTORNEY

H. B. MALLORY.
HAT TIP CLIPPING MACHINE.
APPLICATION FILED MAR. 11, 1910.

998,191.

Patented July 18, 1911.

3 SHEETS-SHEET 2.

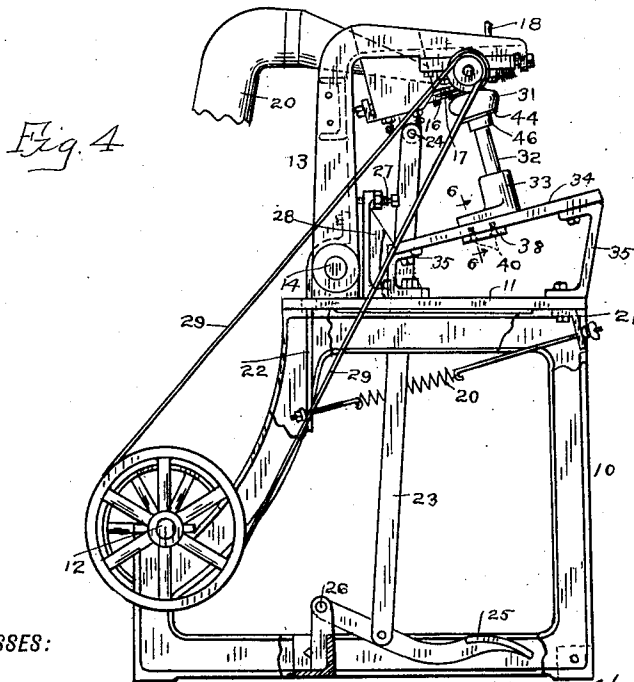
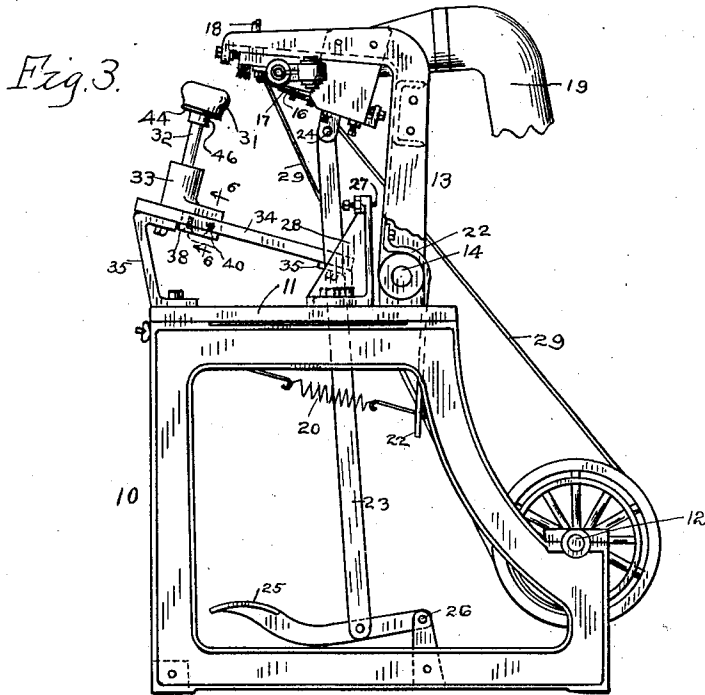

WITNESSES:

Ernst P. Wold
S. W. Aikerton.

INVENTOR

Harry B. Mallory
BY *A. W. Woster*
ATTORNEY

H. B. MALLORY.
 HAT TIP CLIPPING MACHINE.
 APPLICATION FILED MAR. 11, 1910.

998,191.

Patented July 18, 1911.

3 SHEETS—SHEET 3.

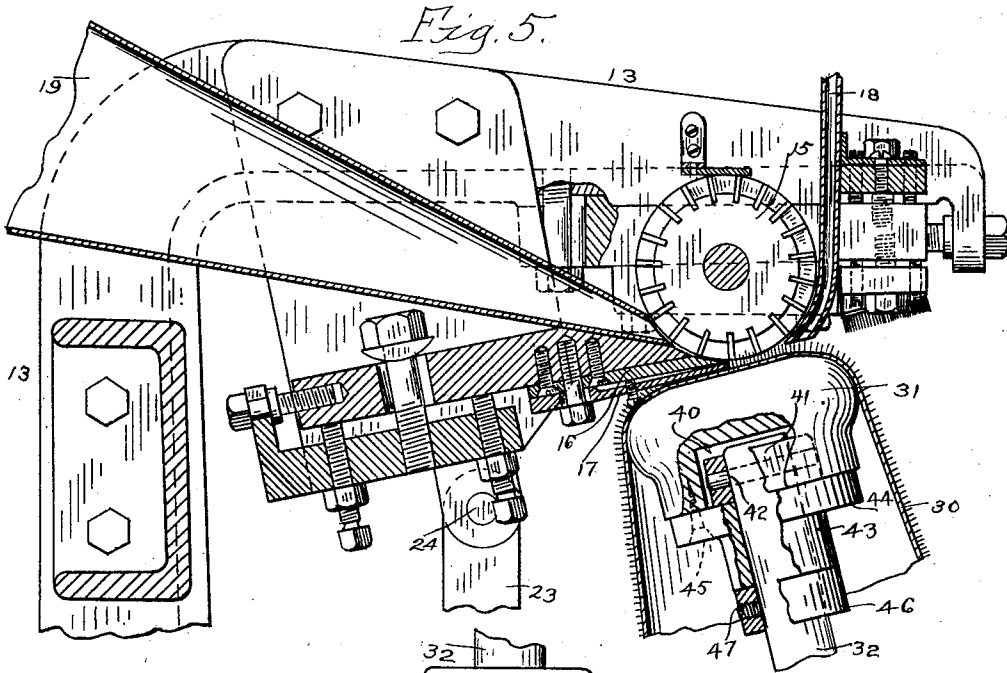

Fig. 6.

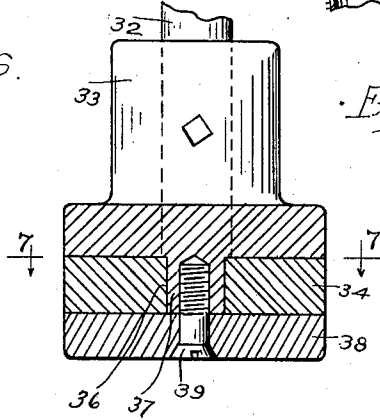
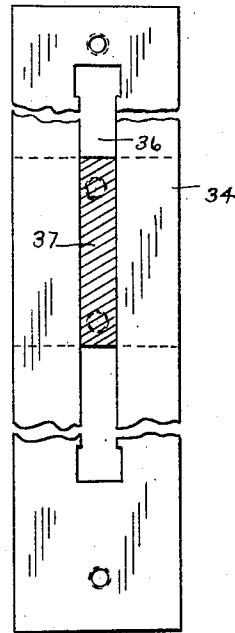

Fig. 7.



WITNESSES:

Ernest P. Wold
S. W. Atherton

INVENTOR

Harry B. Mallory
 BY *A. W. Wooster*
 ATTORNEY

UNITED STATES PATENT OFFICE.

HARRY B. MALLORY, OF DANBURY, CONNECTICUT, ASSIGNOR TO E. A. MALLORY AND SONS, INCORPORATED, OF DANBURY, CONNECTICUT, A CORPORATION OF CONNECTICUT.

HAT-TIP-CLIPPING MACHINE.

998,191.

Specification of Letters Patent. Patented July 18, 1911.

Application filed March 11, 1910. Serial No. 548,694.

To all whom it may concern:

Be it known that I, HARRY B. MALLORY, a citizen of the United States, residing at Danbury, county of Fairfield, State of Connecticut, have invented an Improvement in Hat-Tip-Clipping Machines, of which the following is a specification.

This invention has for its object to provide a machine for clipping the long fur and hair on the tips of fur hat bodies to a predetermined length.

It is of course well understood that ordinary hat clipping machines clip the bodies clear to the tips but do not clip the tips and cannot be made to, which renders a separate operation for clipping the tips necessary.

My present invention comprises an attachment which may be applied to ordinary hat body clipping machines by removing the body carrying mechanism and which will enable the operator to clip the tips of hat bodies uniformly and rapidly and without danger to the hands of the operator.

With these and other objects in view I have devised the novel hat tip clipping machine of which the following description in connection with the accompanying drawings is a specification, reference characters being used to indicate the several parts:

Figure 1 is a front elevation of the machine partly broken away; Fig. 2 a plan view partly broken away; Fig. 3 a side elevation as seen from the right in Fig. 1; Fig. 4 a side elevation as seen from the left in Fig. 1; Fig. 5 a sectional view on an enlarged scale on the line 5—5 in Fig. 1, looking in the direction of the arrows; Fig. 6 a detailed sectional view on an enlarged scale on the line 6—6 in Fig. 3, looking in the direction of the arrows; and Fig. 7 is a detail sectional view on the line 7—7 in Fig. 6, looking in the direction of the arrows.

In Figs. 1, 2 and 3 the parts are shown in their normal position and in Figs. 4 and 5 in their operative position.

In order that the operation of my novel attachment may be perfectly clear I will briefly describe the essential parts of a clipping machine to which I have applied it. It should be understood, however, that my novel attachment is equally applicable to the various other types of hat body clipping machines now upon the market.

10 denotes framework which supports a

bed 11 and 12 a driving shaft to which power is applied in any suitable manner as by means of a belt (not shown).

The clipping mechanism is carried by an inverted L-shaped swinging frame 13 which is pivoted to the bed, as at 14.

15 denotes a clipping cylinder which is adjustably journaled in the swinging frame. Coöperating with the clipping cylinder is a bed knife 16 which is adjustably secured to the swinging frame. Below the clipping cylinder is an adjustable guard plate 17 which may or may not be used and which is adapted to bear upon the hat body. The object of this guard plate is to cause the swinging frame with the clipping cylinder and bed knife to rise and fall in use should there be thickened portions in the hat bodies, and thereby prevent injury to the bodies and insure a uniform length of the nap without regard to varying thickness of the bodies.

18 denotes a combined finger guard and suction pipe which may be placed just in front of the clipping cylinder, which renders it impossible for the fingers of the operator to get to the cylinder knives and also acts to raise the nap upon the hat bodies. 19 denotes another suction pipe just back of the clipping cylinder which removes from the machine all the hairs that are clipped at the cutting line.

The swinging frame and clipping mechanism are normally held out of operative position by means of a spring 20, one end of which is secured to a bracket 21 on the under side of the bed and the other end to an arm 22 which extends downward from the swinging frame. The swinging frame and clipping mechanism are drawn forward into the operative position by means of a rod 23, one end of which is connected to the swinging frame as at 24, the other end being pivoted to a treadle 25 which is itself pivoted to the framework as at 26. The position to which the swinging frame and clipping mechanism are carried when swung into operative position is determined by stop screws 27 in brackets 28 which are rigidly secured to the bed, the side pieces of the swinging frame when in operative position bearing against the ends of the stop screws. This adjustment determines the height of the cutting line and enables the operator to clip the hairs to any predetermined length. The clipping cylinder is driven by means of a

belt 29 passing over pulleys on the driving shaft and the cylinder shaft.

30 denotes a hat body that is being operated upon. The bodies are placed singly upon a holder 31 which is adapted to be passed forward and backward under the clipping mechanism when the latter is in operative position. This holder, which may be made of any suitable material, preferably of wood, is a circular head flat across the top and so shaped that when a hat body is drawn down over it, as in Fig. 5, the tip will be stretched out flat so that it may be subjected to the action of the clipping mechanism which is thus permitted to act effectively on that portion of a hat body not operated upon by an ordinary body clipping machine. This holder is carried by a standard 32 rigidly secured to a base 33 which is adapted to slide on a carrying plate 34 secured at a suitable and convenient incline to brackets 35 which are themselves rigidly secured to the bed. I have shown the carrying plate as provided with a slot 36 and the base which carries the standard is provided with a central web 37 which is adapted to slide in the slot, the holder, standard and base being secured to the carrying plate by means of a plate 38 on the under side of the carrying plate which is secured to the web by screws 39. The holder may be either rotatably or rigidly secured to the standard. I preferably, however, make the holder rotatable on the standard. In the present instance I have shown the holder as provided with a recess 40 in its under side which receives the upper end of the standard and a collar 41 rigidly secured thereto as by a pin 42. Below the holder is a collar 43 which is free to rotate on the standard and is provided with a flange 44 which is secured to the holder as by screws 45. Below collar 43 is a holding collar 46 which is rigidly secured to the standard as by a set screw 47. In practice the entire weight of the holder rests upon the holding collar instead of upon the end of the standard, which reduces friction to the minimum and leaves the holder firmly supported and secured but preferably free to rotate.

The operation is briefly as follows: The operator pulls the hat body to be operated upon down over the holder firmly so as to stretch out the tip, as shown in Fig. 5. He then places his foot upon the treadle and swings the clipping mechanism into operative position and then passes the holder with the hat body thereon forward and backward under the clipping mechanism two or three times, as may be required, partly rotating the holder with the hat body thereon on the standard (or the hat body on the holder should the latter be rigid) after each forward movement so as to change the line of cut relatively to the hat body each time it is

passed under the clipping mechanism and to be sure to clip the entire tip effectively and uniformly.

Having thus described my invention I claim:

1. In a machine of the character described the combination with clipping mechanism, of a carrying plate, a base, means for slidably connecting said base and said carrying plate, an upright standard having one end mounted in said base, and a holder over which the tips of the hat bodies are stretched, said holder having a recess to receive the other end of said standard. 70 75

2. In a machine of the character described, the combination with clipping mechanism, of an inclined carrying plate, a base, means for slidably connecting said base and said carrying plate, an upright standard having one end mounted in said base, and a rotatable holder over which the tips of the hat bodies are stretched, said holders having a recess to receive the other end of said standard. 80 85

3. An attachment of the character described comprising a carrying plate, a base adapted to reciprocate thereon, an upright standard having one end rigidly secured to said base and a holder rotatably mounted on the other end of said standard. 90 95

4. An attachment of the character described comprising a rotatable holder, a standard by which it is carried, a base for the standard having a web, a carrying plate having a slot in which the web may reciprocate and a plate under the carrying plate which is secured to the web. 100

5. In a machine of the character described, the combination with clipping mechanism and an inclined carrying plate having a slot, of a holder over which the tips of hat bodies are stretched and a standard therefor having a base adapted to reciprocate on the carrying plate. 105

6. In a machine of the character described, the combination with clipping mechanism and an inclined carrying plate having a slot, of a rotatable holder over which the tips of hat bodies are stretched, a standard therefor provided with a web which reciprocates in the slot and means for securing the base on the carrying plate. 110 115

7. In a machine of the character described, the combination with a clipping cylinder and bed knife, a swinging frame by which they are carried, means for normally retaining the swinging frame out of operative position and means for throwing it into operative position, of a holder over which the tips of the hat bodies are stretched, a standard therefor having a base and an inclined carrying plate on which the standard may reciprocate. 120 125

8. In a machine of the character described, the combination with a clipping cylinder 130

and bed knife, a swinging frame by which they are carried and means for limiting the forward movement of the swinging frame, of a holder over which the tips of hat bodies
5 are stretched, a standard therefor having a base and an inclined carrying plate on which the standard may reciprocate.

In testimony whereof I affix my signature in presence of two witnesses.

HARRY B. MALLORY.

Witnesses:

FRED T. JOY,
WM. C. SMITH.

Copies of this patent may be obtained for five cents each, by addressing the "Commissioner of Patents, Washington, D. C."
