

T. TRIPP.  
 Metallic Packings for Piston Rods, &c.  
 No. 219,883.                      Patented Sept. 23, 1879.

*Fig. 1.*  
*On line a b of Fig. 2.*

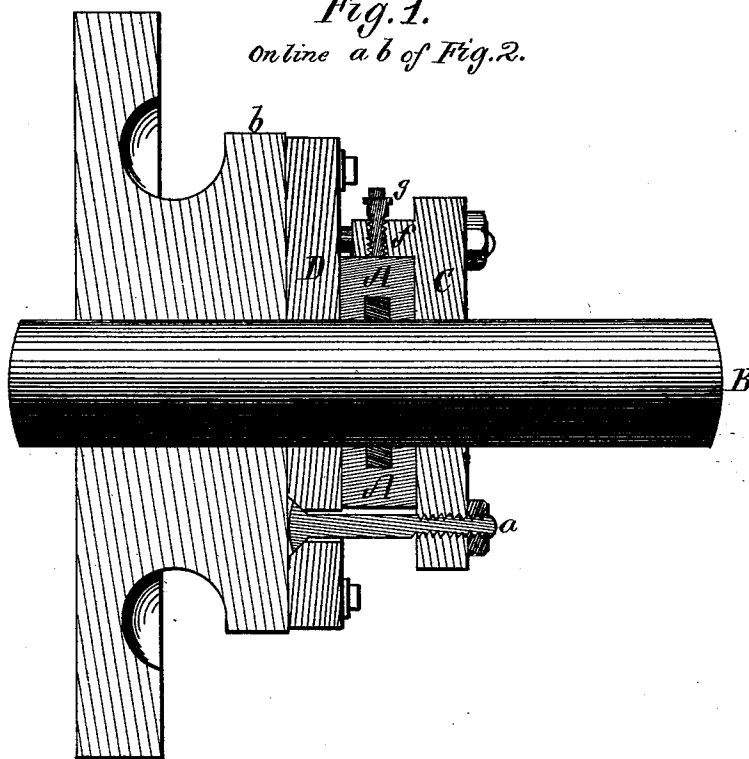

*Fig. 2.*

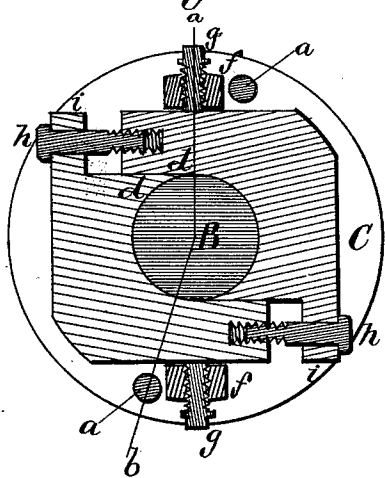

*Fig. 3.*

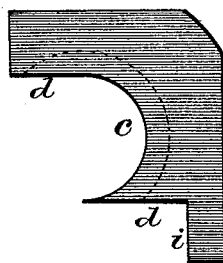

*Witnesses.*  
*Wm. Turrell Andrews Jr.*  
*Louis A. Curtis.*

*Inventor.*  
*Thomas Tripp.*  
*J. Curtis. Atty.*

# UNITED STATES PATENT OFFICE.

THOMAS TRIPP, OF EAST STOUGHTON, ASSIGNOR TO THE AMERICAN METALLIC PACKING ASSOCIATION, OF BOSTON, MASSACHUSETTS.

## IMPROVEMENT IN METALLIC PACKINGS FOR PISTON-RODS, &c.

Specification forming part of Letters Patent No. 219,883, dated September 23, 1879; application filed February 25, 1879.

*To all whom it may concern:*

Be it known that I, THOMAS TRIPP, of East Stoughton, in the county of Norfolk and State of Massachusetts, have invented certain new and useful Improvements in Metallic Packings for Piston-Rods, &c., of which the following is a specification.

My present improvements relate to a class of sectional metallic packings for piston-rods of steam-cylinders, &c., shown and described in Letters Patent of the United States issued to myself on the 4th day of February, A. D. 1879, the distinguishing feature of which consists in the employment of twin semi-rings capable of sliding upon one another in a plane at right angles to the axis of the rod, and being maintained in a uniform plane by suitable guides, and crowded up to the rod from opposite sides by means which are controlled and adjusted from the outside of the cylinder-head, an important element in this class of packings being seen in the fact that it is susceptible of lateral slip upon the cylinder-head by and with any eccentric movements of the rod should the latter become bent or out of true from any cause.

In my patented packing above referred to the rings are crowded up to and inclose the rod from opposite sides by inclined planes or sloping cams secured to an annular disk or collar sliding upon the rod, while the rings themselves are prevented from separation by pins and grooves properly arranged. In my present packing I retain the twin rings and the annular disk, as shown in my patent above referred to, but discard the inclined planes or cams, and substitute for the latter two or more bolts, screwing into the outer end of each ring, and swiveled to an ear projecting from the adjacent part of each opposite ring, while in lieu of the pins and grooves employed in my patent I make use simply of two lugs, projecting laterally inward from the inner face of the annular disk before named, which encompasses the rod outside of the rings, an adjusting-screw or its equivalent being employed with each lug, and bearing against the outer edge of each ring, to compel a close bearing between the sides of the peripheries of the ring and the

rod, and to vary the degree of friction between them should it be found desirable.

The drawings which accompany this specification and illustrate my invention represent, in Figure 1, a longitudinal section, and in Fig. 2 a cross-section, of a packing containing my improvements, while Fig. 3 is a face view of one of the sectional packing-rings.

In the above-named drawings it will be seen that the pair of twin semi-rings are shown at A A as embracing opposite sides of the piston-rod, which is shown at B, while C represents an annular disk loosely encompassing such rod, and confined or connected to an annular head, D, which also encompasses the rod, by two or more bolts, *a a*, while the last-named head, D, is rigidly bolted to the cylinder-head, or to the outstanding flange *b*, in which such cylinder-head usually terminates.

I term the sectional packing-plates "semi-rings" for the reason that the corresponding portions of metallic-rod packings in general are styled "sectional rings," and because their united bores constitute a cylindrical bearing which embraces the rod.

In the present instance these rings A A are flat and practically triangular blocks of metal, of like size and shape, each having a semicircular recess or depression, *c*, in one corner, and with straight parallel edges or faces *d d*, which meet and slide upon one another, and provide a common circular opening to receive the piston-rod, such rings being inclosed between the disk C and head D, and by them maintained in a uniform common plane and prevented from separation endwise of the rod. The rings A A are prevented from lateral spreading or separation with respect to each other by lugs *f f*, extending inward from the disk C; and I prefer to employ adjusting-screws *g g*, or their equivalents, with these lugs, to vary the friction between the sides of the rings and the rod, and to compensate for wear, should any occur at this point.

To crowd the rings A A endwise, as it may be termed, against opposite sides of the rod—that is to say, in a direction at right angles to the direction of the pressure exerted by the screws *g g*—I employ with each a bolt, *h*, which

is swiveled, in any suitable manner, to an ear, *i*, projecting laterally from the outer end of each ring, and screws into the adjacent part of the opposite ring, these bolts being disposed upon diametrically opposite sides of the rod B, in order the better to exert a uniform pressure or friction upon the circumference of the latter.

I here desire to call especial attention to the fact that the rings A A are, by means of the disk C and head D, maintained at all times in the same plane with respect to each other longitudinally of the rod, or, in other words, are always opposite each other. This is important, for the reason that if these respective positions should be changed an unequal strain and wear would eventuate upon the rod.

The bolts *a a*, which confine the disk C to the head D, are swiveled at their outer ends or heads loosely in the head, in order to be susceptible of a certain freedom of lateral motion or play to permit of slight lateral movement or slip of the rings upon the cylinder-head, in order that they and the disk may follow any eccentric or abnormal movements of the rod should the latter from any cause become bent or out of true with the bore of the cylinder, and to maintain the rings always in a position at right angles to the axis of the rod. This is a peculiar and valuable feature of my packing, and provides a complete relief from the unequal wear and other injurious effects of the thrusts and strains to which metallic packings are subjected. The bolts *a a* further serve to confine the rings to the cylinder-head with

sufficient pressure to prevent escape of steam between the two.

My present packing is simpler, less expensive, and easier to adjust than that shown in my patent before cited. I dispense with springs, now usually employed in packings of this character, and I obviate loosening or starting of the joints of the packing from irregular movements of the rod, as the entire packing device follows the movements of the rod, and slides laterally upon the cylinder-head without starting the joint between them. The device is entirely outside of the cylinder, and hence always accessible.

I claim—

1. The twin semi-rings closing upon opposite sides of the rod, and crowded up thereto by the bolts, each bolt being swiveled to or passing loosely through one ring, and screwing into or otherwise connected to the opposite ring, and arranged upon diametrically opposite sides of such rod.

2. The combination of the twin semi rings, annular disk, and lugs, with or without the adjusting-screws of the latter.

3. In combination with the rings A A, disk C, and head D, the bolts *a a*, as swiveled loosely in the said head, to permit of lateral slip of the rings and disk upon it by and with any eccentric or irregular movements of the rod.

THOMAS TRIPP.

Witnesses:

LOUIS A. CURTIS,

F. HUNNEWELL.