



(12) PATENT ABRIDGMENT (11) Document No. AU-B-74900/94
(19) AUSTRALIAN PATENT OFFICE (10) Acceptance No. 687434

- (54) Title
SMOKING OR INHALATION DEVICE
- International Patent Classification(s)
 (51)⁶ **A24F 047/00**
- (21) Application No. : **74900/94** (22) Application Date : **17.08.94**
- (87) PCT Publication Number : **WO95/05094**
- (30) Priority Data
- | | | |
|----------------|-----------------|-------------------|
| (31) Number | (32) Date | (33) Country |
| 4328243 | 19.08.93 | DE GERMANY |
- (43) Publication Date : **14.03.95**
- (44) Publication Date of Accepted Application : **26.02.98**
- (71) Applicant(s)
SVEN MIELORDT
- (72) Inventor(s)
SVEN MIELORDT
- (74) Attorney or Agent
SPRUSON & FERGUSÓN , GPO Box 3898, SYDNEY NSW 2001
- (56) Prior Art Documents
EP 358002
GB 526678
US 4141369
- (57) Claim

1. A device for smoking tobacco or another smoking product or for the inhalation of aerosols released by the heating of an aerosol releasing substance, comprising

- a reservoir forming a substantially closed chamber for containing the smoking product or the aerosol releasing substance in crushed or finely distributed form, and
- a hot carrier gas generator comprising a heating appliance with an outlet for introducing the heated carrier gas into the chamber,

wherein the heated carrier gas causes a heating by convection of the smoking product or the aerosol releasing substance to a temperature below that of the product's glow temperature and

the smoking product or the aerosol generating substance is arranged in the chamber and/or guided in such a way that the surfaces of its particles will be directly affected by the carrier gas stream emitted from the outlet , and the volumes of the particles will be warmed through up to a temperature close to but lower than said glow temperature.

2. A device for smoking tobacco or another smoking product or for the inhalation of aerosols released by the heating of an aerosol releasing substance, comprising

- a reservoir forming a substantially closed chamber for containing the smoking product or the aerosol releasing substance,
- a radiation heating appliance directly affecting the smoking product or the aerosol releasing substance, and
- a suck-in opening for guiding a carrier gas being optionally heated around the smoking product or the aerosol releasing substance within the chamber to a suck-off opening for the smoke or the aerosol,

wherein the smoking product or the aerosol generating substance is arranged and/or guided in such a way that it will be warmed through up to a temperature close to but lower than said glow temperature and will be streamed along by the carrier gas in this state.



<p>(51) Internationale Patentklassifikation ⁶ : A24F 47/00</p>	<p>A1</p>	<p>(11) Internationale Veröffentlichungsnummer: WO 95/05094 (43) Internationales Veröffentlichungsdatum: 23. Februar 1995 (23.02.95)</p>
<p>(21) Internationales Aktenzeichen: PCT/DE94/00991 (22) Internationales Anmeldedatum: 17. August 1994 (17.08.94) (30) Prioritätsdaten: P 43 28 243.1 19. August 1993 (19.08.93) DE (71)(72) Anmelder und Erfinder: MIELORDT, Sven [DE/DE]; Großbeerensstrasse 81, D-10963 Berlin (DE). (74) Anwalt: CHRISTIANSEN, Henning; Pacelliallee 43/45, D-14195 Berlin (DE).</p>	<p>(81) Bestimmungsstaaten: AM, AU, BB, BG, BR, BY, CA, CN, CZ, FI, GE, HU, JP, KG, KP, KR, KZ, LK, LT, LV, MD, MG, MN, NO, NZ, PL, RO, RU, SI, SK, TJ, TT, UA, US, UZ, VN, europäisches Patent (AT, BE, CH, DE, DK, ES, FR, GB, GR, IE, IT, LU, MC, NL, PT, SE), OAPI Patent (BF, BJ, CF, CG, CI, CM, GA, GN, ML, MR, NE, SN, TD, TG), ARIPO Patent (KE, MW, SD).</p> <p>Veröffentlicht <i>Mit internationalem Recherchenbericht. Vor Ablauf der für Änderungen der Ansprüche zugelassenen Frist. Veröffentlichung wird wiederholt falls Änderungen eintreffen.</i></p> <p style="text-align: center; font-size: 2em; font-weight: bold;">687434</p>	

(54) Title: SMOKING OR INHALATION DEVICE

(54) Bezeichnung: RAUCH- ODER INHALATIONSVORRICHTUNG

(57) Abstract

A device is disclosed for smoking tobacco or another smoking product (13) or for inhaling aerosols released by corresponding substances when they are heated. The substance that constitutes the smoking product is shredded, granulated or otherwise crushed. The smoking product contained in a reservoir (12) that forms a substantially closed chamber (16) is heated by convection by previously heated air up to a temperature below its glow temperature. An electric heating device (8) that forms a heating air generator (7) arranged in a channel is provided with an outlet nozzle (9) for introducing the heated air into the chamber after the air runs through the heating device and absorbs heat energy. The smoking product (13) is spread in a substantially even manner on a saucer-like surface (12) in the chamber (16). The outlet nozzle is arranged in such a way that the heated air that flows out of the nozzle flows directly on to the smoking product and heats it through up to a temperature close to but lower than its glow temperature.

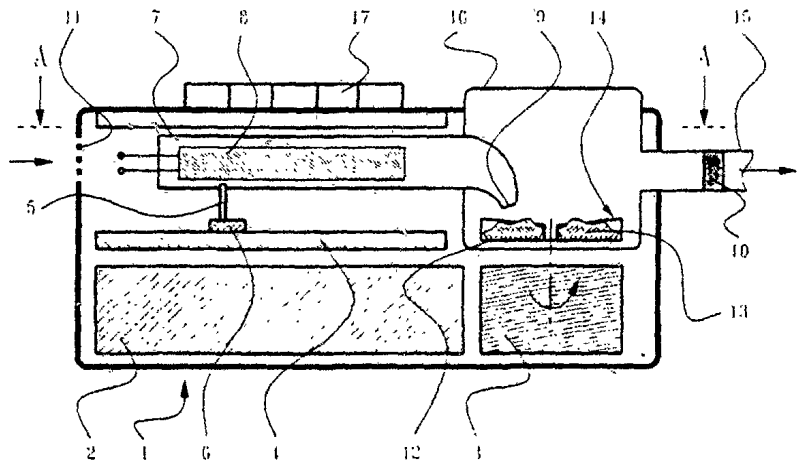

5

10

Smoking Or Inhalation Device

DESCRIPTION

15 The invention discloses a device of the kind given
in the generic term of patent claim NO. 1.

 The consumption of tobacco products by choice is a
common form of recreational/social drug use. The smoking
of tobacco does, however, entail the ingestion (through
20 the respiratory system) of typical toxic by-products.
Smokeable products develop these by-products at
combustion temperatures of 800- 1000 degrees centigrade;
they consist of tar, condensate or heavily volatile
carcinogenes as well as carbon monoxide and other toxic
25 inorganic substances- heavy metals, for example; all in
constrast to the usually mostly minimal toxic content of
the drug itself. Experiments have shown that the release
of alkaloids and active products (for example nicotine)

./..

which contribute to the enjoyment of smoking occur at temperatures as low as 100 degrees centigrade.

Such devices can also be used in the interests of health (the treatment of addiction to cigarettes, for example) by introducing pharmaceutically effective aerosols (released from substances reached by the air stream) to the air flow during the heating process.

A device already exists, namely the application number EP-A2 358002 or the DE-U-92 18 005.1, which heats the smoking product by means of a gas flow, preferably air, which has been electrically preheated. A batterie-powered resistance heater has been provided for this purpose. The smoking product is convection heated to a temperature lower than that at which combustion occurs and harmful substances are able to form, or to a temperature at which the formation of these substances is reduced, thus facilitating smoking enjoyment by releasing the relevant stimulating aerosols.

In the aforementioned device the smoking product is compressed to a cylindrical mass and heated air flows lengthwise through the mass, always in the same direction. It should also be noted that it is not possible to move this mass -which varies from lightly to heavily compressed- in relation to the heated gas/fluid or the electrical heating source.

The disadvantage is that the heated air affects only the directly exposed surface areas of the smoking product and is thus able to heat only this surface area to the desired temperature, i.e. that at which aerosols are released which contribute to the enjoyment of smoking. After longer periods of exposure to the heated air, the

smoking product can become subject to localised overheating. This overheating can in turn lead to carbonisation and combustion and the attendant possibility of the formation of toxic substances. Furthermore, the product will remain only partially consumed, since the greater part of it will not have been heated to a sufficient temperature.

5 This not only leads to higher energy consumption (since the periods during which the product is heated are independent from the smoke's flow rate) but also to an inefficient and incomplete consumption of the product itself. Given the drawbacks of the current technology it is now the task to create a device of the aforementioned kind which enables, quite simply, a more or the most efficient consumption of a given
10 smoking product and, more particularly, the creation of a desired smoking profile.

Accordingly, in a first aspect, the present invention provides a device for smoking tobacco or another smoking product or for the inhalation of aerosols released by the heating of an aerosol releasing substance, comprising

- a reservoir forming a substantially closed chamber for containing the
15 smoking product or the aerosol releasing substance in crushed or finely distributed form, and

- a hot carrier gas generator comprising a heating appliance with an outlet for introducing the heated carrier gas into the chamber,

20 wherein the heated carrier gas causes a heating by convection of the smoking product or the aerosol releasing substance to a temperature below that of the product's glow temperature and

the smoking product or the aerosol generating substance is arranged in the chamber and/or guided in such a way that the surfaces of its particles will be directly affected by the carrier gas stream emitted from the outlet, and the volumes of the
25 particles will be warmed through up to a temperature close to but lower than said glow temperature.

In a second aspect, the present invention provides a device for smoking tobacco or another smoking product or for the inhalation of aerosols released by the heating of an aerosol releasing substance, comprising

30 - a reservoir forming a substantially closed chamber for containing the smoking product or the aerosol releasing substance,

- a radiation heating appliance directly affecting the smoking product or the aerosol releasing substance, and

35 - a such-in opening for guiding a carrier gas being optionally heated around the smoking product or the aerosol releasing substance within the chamber to a suck-off opening for the smoke or the aerosol.

wherein the smoking product or the aerosol generating substance is arranged and/or guided in such a way that it will be warmed through up to a temperature close to

but lower than said glow temperature and will be streamed along by the carrier gas in this state.

The invention is contingent upon the recognition that the effective and thorough exploitation of the substance from which aerosols are to be extracted is possible when the smoking product is evenly and, particularly, sequentially heated to a temperature below that at which it will combust and thus release harmful by-products. This condition in particular can be achieved if a relatively finely-distributed quantity of the smoking product-possible in smaller discrete quantities-is convection heated by carrier gas flow, particularly air, directly onto the product in such a way as to ensure that the volume bodies of smoking product particles can

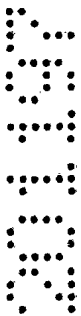
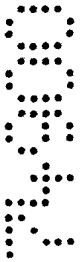

be heated near the surface by the introduced carrier gas, directly affected, and warmed through as most as possible. This prevents what occurs in cartridge-like assemblies - carrier gas, which has already cooled down, reaches the interior parts of the compressed smoking product and is incapable of heating it at these points to the desired temperature. This is quite clearly inefficient and rules out the use of such devices as a basis for further design.

10 In the aforementioned cartridge-like assemblies, it would also be possible to heat the air to such a temperature that the inner areas of the smoking product would be sufficiently heated. This would, however, as mentioned previously, result in overheating and combustion of the surfaces first reached by the heated air. The resulting by-products are, as we have established, harmful and thus undesirable.

20 The desired temperatures can be achieved if the heat affected surface of a smoking product which has been chosen is large in ratio to the volume of the smoking product surrounded by this surface. A desired smoking profile may be software-determined by means, for example, of user-defined smoking product temperatures, corresponding feed rate of the smoking product as well as an oscillation of the relative position between product and hot air jet.

30 By means of the above mentioned temperature regulation, the formation of organic carcinogenes and the release of inorganic toxins (heavy metals and carbon monoxide) can be stopped or at the very least considerably reduced.

An advantageous further development of this invention would be to "pulse" heating; in this way the temperature of the product itself does not rise to that of combustion, when it is taken care of the thermal time constants acting in combination, even if the air is shortly super-heated. In this way it is possible at any time to rapidly reach the temperature at which the most efficient exploitation of the smoking product occurs, thus minimizing the amount of air at the initial phase of the heating process (enriched with only low concentration of aerosol) and corresponding loss of enjoyment for the consumer.

The temperature at which the smoking product "glows" provides a good criterion by which we can recognize the process, since the rapidly increasing red and infra-red radiation suggests the regulation or exclusion of hot air flow. This "glow" appears also with the use of inert gas as a heat carrier. By keeping track of the glow, one is able to control the process, even when using air as a carrier gas, since the air flow can be regulated before combustion occurs.

In a preferred embodiment of the invention, the entire quantity of the smoking product is distributed in a reservoir with several chambers of roughly equal size. Each chamber is convection heated by means of a jet of air which has been pre-heated to the required temperature in a hot air generator. The hot air generator is, in turn, powered by a (preferably) electrical heating appliance. The air to be warmed is sucked or inhaled by the smoker from the air surrounding the device into the hot air generator. In order to heat up the entire quantity of smoking product sequentially and evenly and

to be able to extract the maximum quantity of aerosol, discrete quantities are partially heated in lots. For this purpose it is possible to move the hot air jet or stream in relation to the smoking product. The reservoirs containing the smoking product are able to be moved while the hot air stream is fixed; this facilitates simpler operation. A shallow, cylindrical reservoir is slowly revolved by the inbuilt drive unit and thereby exposed in circular sections to the hot air stream. The circular reservoir is divided correspondingly into chambers of equal size, each containing an equal quantity of smoking product. For the generation of individual smoking profiles it is advantageous to be able to control the movement of the smoking product in relation to the quantity and temperature of the supplied air.

In order to stabilise the relative position of each discrete quantity of smoking product, it is advisable to use a restraint grille.

It is also possible to use pre-fabricated or pre-formed tablets or other flat-shaped bodies which can then be inserted into the device; they hold quantities of smoking product and can be directly affected by gas flow.

According to an advantageous further development of the invention, the reservoir forms a shallow cuboid and is provided with cuboid compartments. A drive unit would be given to move the reservoir translatorily, thus warming the smoking product equally in each of the chambers. The movement under the hot air jet occurs steadily or gradually (stepped), controlled by a predetermined program.

The invention displays - at least in some respects -

./..

further advantages and possible directions for subsequent development:

In order to achieve constant heating independent of strength or quantity of inhalation of the smoker, flow-rate dependant regulation of electrical energy fed into the hot air generator would be employed. Making use of the physical correlation between flow velocity, quantity of fluid flow and flow pressure, the quantity of air transported from the air surrounding the machine into the hot air generator by the sucking or inhalation of the smoker would be measured by a differential pressure sensor and the value fed into a controller which would, in turn, supply the appropriate amount of heating power. In the case of low heat capacity of the heating appliance element, the desired temperature profile can be delivered within short periods of time.

The hot air generator allows the air to be heated in an electrical heating appliance, whereby air sucked from the environment will be raised to a temperature above that at which the pyrolytic formation of aerosol occurs in the smoking product. This super-heating is necessary in order to compensate for the inevitable heat loss /time constant between the heating inside the hot air generator and heating of the smoking product. A further possible development improvement: the heating appliance could be manufactured as a strip-shaped foil element. To lower flow resistance and increase surface contact of the foil element with the fluid flow to be heated, the foil would be bent into a U-shape and provided with several circular and/or slot-shaped openings on its surface. The U-shape is parallel to the flow direction of the air to be heated which flows into the U-shaped inlet. An additional

improvement could be that the heating appliance be shaped t ape-like, lightly bulbous, with side walls on whose surface would be enhancing protuberances such as circular nipples or conical fingers.

5 Another advantageous subsequent development of the invention is the employment of an inert gas in the convection heating of the smoking product; that would further reduce the development of harmful substances.

10 Optimized exploitation of the smoking product requires an almost isothermal heating of the discrete product quantities. Up to a point, physical laws will always result in the areas near the surface of the smoking product being primarily affected when coming into contact with the carrier gas flow.

15 Compared to the current technology, this invention displays very even heating of sequentially activated particles with a high degree of penetration relative to particle size, simply by directing the hot air flow onto the smoking product's relative thinness and large surface
20 area. In this text, this fact will also be clarified by the terms "sequentially homogeneous", "equal" or "uniform". When focussing radiation energy onto the volume area of the affected smoking product's zone, the release of aerosols can also be induced. The use of
25 UV/visible light or short-wavelength infra-red radiation heats particles' surfaces to a temperature slightly higher than their interiors (as is the case with the use of hot air flow) since radiation is absorbed at the surface. However, the use of longer wavelength radiation
30 (microwave or radio frequencies, for example) will result in the absorption of radiation energy by the entire

volume of the affected smoking product by virtue of
(amongst other things) dielectrical losses in the high
frequency field. In this way, particle cores become
hotter than their surfaces, since the flow of carrier gas
5 still needed for transportation of the smoking products`
aerosol tends to cool the surfaces by convection. An
almost gradient-free heating of the particles at a given
finite depth of penetration can thus be achieved: heated
carrier gas is directed onto the particles which are
10 simultaneously exposed to penetrating absorbable
radiation energy. This would create such a temperature as
to heat the particle cores to an even higher temperature
than that of the hot-air affected particle surfaces,
causing an increase of the aerosols` vapour pressure
15 inside the particle cores and thus facilitating an
increase in aerosol diffusion to the surface and an
improvement of efficiency relative to toxicity. Shock-
pulse super-heating of particle cores by radiation can
also be effective: the particle's structure becomes
20 loosened, with the attendant increase of affected surface
area. Focussing of radiation is usually annular or from
at least two canted surfaces. The saucer for the smoking
product can be made reflective.

It is advisable, when using software-controlled
25 smoking profiles, to exploit the smoking product in
several successive "recycling" phases. A feed rate can be
established by moving the heat-affected zones of the
smoking product in relation to sucked carrier gas volume
and nominal temperature whereby the initial "draw" (the
30 smoker`s inhalation) requires little or no feed rate,
since the smoking product needs to be heated up. When the
entire surface area of the smoking product has been
affected, the second phase begins - the temperature is

increased and a higher feed rate introduced, the latter due to the approaching exhaustion of product. A third and final phase, where all parameters are progressively increased, will find the smoking product fully consumed
5 and no longer smokeable. Particularly at high temperatures, it is favourable to have an overlapping oscillation of the relative position between hot carrier gas jet and the affected zone.

Subsequent advantageous developments and
10 improvements of the invention will be enumerated in the sub-claims or will be further detailed in the following text and in the diagrams of the preferred embodiments of the invention.

Diagrams:

15 FIG. 1 is a schematic representation of a longitudinal cross-section through a preferred embodiment of the invention (across the A-A line in FIG. 2);

FIG. 2 shows another cross-section of this realisation;

20 FIG. 3 to 3f demonstrate further advantageous developments of the invention shown in FIGs. 1-2;

FIG. 4 shows another favourable embodiment of the invention in simplified depiction;

FIG. 5 is a schematic representation of a variation of the version in FIG. 4;

25 FIG. 6 is a further advantageous realisation of the invention in cross-section;

FIG. 7 is another advantageous embodiment of the invention in cross-section.

./..

The appliance 1 depicted in FIG. 1 as a longitudinal cross-section across the line A...A of FIG. 2 for the smoking of tobacco or other smoking products is essentially equipped with a hot air generator 7. Heated air leaving the hot air generator 7 is used to convection heat the smoking product 13. The smoker inhales from a standpipe 15 the required quantity of air through an inlet 11 provided in the wall of the housing. In this flow path, the hot air generator 7 is integrated in such a way that ambient air sucked through the inlet 11 will reach the hot air generator 7 directly, to then flow along a heating appliance 8. This results in heating of the smoking product in areas near the surface.

The air outlet nozzle 9 of the hot air generator 7 is directed into the smoking chamber 16 of the smoking device 1, the outlet being positioned closely to the smoking product 13 in the reservoir 12. At this point, the heated air reaches a temperature at which the smoking product 13 becomes pyrolytically converted to release aerosols. Due to the convection heating of the smoking product 13, combustion which usually occurs at a minimum temperature of 800 degrees Centigrade (and the attendant formation of harmful products) can be prevented. It is advisable, for the formation of aerosols which contribute to the enjoyment of smoking, to heat the affected particle volumes sequentially, in an essentially even and uniform manner, to their respective pyrolysis temperatures. Because of this, the quantity of smoking product 13 in the reservoir 12 of the smoking chamber 16 is divided into several discrete quantities and distributed amongst the individual chambers 14 of the reservoir 12.

The drive unit 3 rotates the reservoir 12 so that the discrete quantities of smoking product are sequentially exposed to the hot air jet emerging from the outlet nozzle 9. Regardless of whether rotation of the reservoir (pre-programmed by a user-adjustable control unit) occurs steadily or in gradual steps, the quantities of smoking product will be uniformly heated and aerosols extracted with a high degree of efficiency. This provides a uniformly high degree of smoking enjoyment coupled with a highly efficient exploitation of the smoking product and, conversely, negligible losses. In order to fully exploit the smoking product, a uniform temperature of the hot air stream independent of inhalation strength is essential. A regulator is provided for this purpose; the pressure sensor 6 measures the flow velocity within the hot air generator 7 for the regulation of the (preferably electrically powered) heating appliance 8. The pressure sensor 6 is connected to the flow path by means of a tube 5.

To operate the smoking device 1, a battery 2 is provided for the drive unit 3 and the electronic module 4. The control panel 17, equipped with buttons, enables easy on/off switching of the device 1 and the adjustment of the required hot air's temperature range or of the drive unit 3's speed. In this manner it is possible, e.g. via software, to very simply choose a particular smoking profile. The envisaged filter 10 inside the standpipe 15 restrains undesired particles circulating within the smoking chamber 16.

FIG. 2 is a cross-section along the line A...A of FIG. 1. The saucer-like, shallow cylindrical reservoir 12 is divided into several equal segments 14, each being

./..

filled with roughly equal quantities of the smoking product 13.

FIG. 3, 3a-f depict further favourable developments of the invention, showing optimized realisations of the heating appliance 8 from FIGS. 1-2 in schematic form. The heating appliance 8 is a foil element (FIG 3); the foil 24 is U- shaped and air flows between the inner sides of the U. Air flow 23 is admitted through the apertures 25a-d, an implementation or a combination of circular and/or geometrical slots. The heating foil 24 is capable of an advantageously low heat capacity, thus optimising the conditions required for the generation of particular smoking profiles, for the maximum possible consumption of the smoking product, and to facilitate the extraction of the remaining aerosol from chamber 16 without releasing new aerosol from the smoking product 13.

In the event that the electrical heating appliance 8 were to be designed as a compact cuboic heating element or, more particularly, as a thin-walled hollow body 18, 20 with linear or bulbous walls, the surface-area increasing nipples 19 or fingers 21 would facilitate increased heat transfer to the through-flowing air. At the same time a mechanically advantageous stabilisation of the heating element within the flow channel would be accomplished (FIGs. 3e and 3f).

Contacts 22 are provided for the connection of the heating appliance 8 to the control unit of the smoking device.

When the smoking product's position remains static, the relative movement between the hot air stream and the smoking product (necessary for the optimized exploitation

of the latter) is effected by movement of the hot air stream. This is depicted, in cross-section, in FIGs. 4 and 5. The smoking product 13 is placed on a saucer-like, porous and permeable surface 26.1 or on a fine-meshed sieve 26.2. The hot air generator 7 is swivel-mounted in such a way that its air outlet nozzle is able to be directed roughly onto the entire permeable surface 26.1 beneath the smoking product (FIG. 4) or directly onto the smoking product's entire surface as in FIG. 5.

FIG. 6 depicts a further subsequent conception of the invention in cross-section, whereby a quantity of smoking product 13 descends gravitationally (and becomes distributed into small amounts 13.1) via a pre-heatable reservoir 30 into a sieve-like storage compartment 27. Hot air from the hot air generator 7 is directed into the sieve-like storage compartment 27 substantially at right angles to the direction of the descending quantities of smoking product; in this way the relative movement between smoking product and hot air jet can be simply achieved and the smoking product thus optimally activated for the release of aerosols. An anchor-like swizzlestick 31 for stirring and kneading in the storage compartment 27 helps to rearrange the smoking product's particles and exposes them once again to the hot air stream before they at last leave the storage compartment 27 as consumed smoking product 28. Subsequently required smoking product is supplied by means of a plunger 29.

FIG 7 depicts a variation of the smoking device fitted with radiation heating 32. The radiation transversely affects the smoking product 13 which descends into the smoking chamber 16 in smaller lots. The stick of smoking product "burns off" in a downward

direction, starting from the top, to release the desired quantities of aerosols. Inhaled ambient air passing through the standpipe 11 flows in a direction opposite to the descent of the smoking product's subsequently consumed quantities 28, and reaches the smoker via the standpipe 15 enriched with aerosols. Regulation of radiation intensity is achieved in the same way as that of the heating current (as previously described), by measuring the quantity of consumed ambient air required for smoking. To reduce radiation power, it is advisable to preheat the air inhaled into the smoking chamber 16 by means of a previously described hot air generator (not depicted); consumed quantities 28 of the smoking product fall through a grille 34 into a reservoir 33 and are removed as ash-like waste 35.

In another variation of the device (not shown), the housing adjacent to the heating appliance would be transparent so that its glow would be visible when the heating is activated. The heating would, at best, be fixed to the end of the device farthest from the user in order to create the psychological impression of conventional smoking. This effect could also be obtained or enhanced by the appropriate use of a light-emitting diode (LED), most suitably red or orange, which would be activated with the heating appliance.

An additional advantageous subsequent development of the invention would enable the user to choose or shift the individual smoking profile to that of a cigarette or water pipe / hookah.

The principal subjective difference between these traditional smoking methods is that cigarette smokers

inhale relatively small quantities of highly concentrated smoke through a mouthpiece or filter into the mouth and pharyngeal cavity. Further inhalation of fresh air then forces the smoke deeper into the lungs and bronchioles.

5 The water pipe or hookah, on the other hand, allows the user to inhale larger quantities of aerosols with conversely smaller quantities of fresh air thereafter.

 Compared to a water pipe, cigarettes have a relatively high flow resistance. This causes the drawn-in
10 cheeks and puckered lips typical to inhalation of cigarette smoke due to the (even at low flow rates) relatively high underpressure.

 The invention's advantage is that it provides very low flow resistance. The experience of smoking is thus
15 not unlike that of a large water pipe.

 In order to achieve a more cigarette-like smoking profile, especially a soft silicon tube could be connected to the suction standpipe. This would allow the user, while smoking, to pinch the tube with the fingers
20 and thus vary the amount and underpressure of smoke to be inhaled. In this way the decisive subjective-psychological advantages of traditional smoking methods would be simply and variably combined.

 The invention's possibilities are, of course, not
25 limited to the examples given here. A multitude of variations making use of and being within the scope of the invention could be imagineable, even those with fundamentally different construction methods.

The claims defining the invention are as follows:

1. A device for smoking tobacco or another smoking product or for the inhalation of aerosols released by the heating of an aerosol releasing substance, comprising

- a reservoir forming a substantially closed chamber for containing the smoking product or the aerosol releasing substance in crushed or finely distributed form, and

- a hot carrier gas generator comprising a heating appliance with an outlet for introducing the heated carrier gas into the chamber,

wherein the heated carrier gas causes a heating by convection of the smoking product or the aerosol releasing substance to a temperature below that of the product's glow temperature and

the smoking product or the aerosol generating substance is arranged in the chamber and/or guided in such a way that the surfaces of its particles will be directly affected by the carrier gas stream emitted from the outlet, and the volumes of the particles will be warmed through up to a temperature close to but lower than said glow temperature.

2. A device for smoking tobacco or another smoking product or for the inhalation of aerosols released by the heating of an aerosol releasing substance, comprising

- a reservoir forming a substantially closed chamber for containing the smoking product or the aerosol releasing substance,

- a radiation heating appliance directly affecting the smoking product or the aerosol releasing substance, and

- a suck-in opening for guiding a carrier gas being optionally heated around the smoking product or the aerosol releasing substance within the chamber to a suck-off opening for the smoke or the aerosol,

5

wherein the smoking product or the aerosol generating substance is arranged and/or guided in such a way that it will be warmed through up to a temperature close to but lower than said glow temperature and will be streamed along by the carrier gas in this state.

10

3. A device according to claim 1 wherein the smoking product is distributed on a saucer-like surface

15 within the chamber in a substantially even and flat manner.

4. A device according to claim 3 wherein the smoking product is held in position by a mesh, sieve or grille, wherein the supporting surface consists of a sintered material with the ability to act as a filter and/or where the carrier gas generator is mounted in such a way that the carrier gas flowing from the outlet subsequently to having passed through the supporting surface strikes the smoking product.

20

5. A device according to one of the previous claims wherein the reservoir is, through rotation and/or translation, moveable and formed as a shallow, one-sided open cylinder or a flat cuboid with compartments.

25

6. A device according to claim 1 wherein

30

35

the hot carrier gas generator is mounted so that the heated carrier gas leaving the outlet is roughly able to strike the entire surface area of the reservoir covered with the smoking product, wherein the heating appliance preferably is a heating foil element.

7. A device according to claim 1 wherein, the carrier gas at the outlet at the most for a short time achieves a temperature above that of the smoking product's glow temperature, whereby the period of time is measured in such a way that the glow temperature of the smoking product to be heated will not be exceeded, taking into account the thermal time constants.

15

8. A device according to claim 1 wherein, especially programmable, control means for maintaining a predetermined outflow temperature of the carrier gas is provided, wherein the supply of auxiliary energy is adjustable dependant upon the quantity of gas flow through the heating appliance and/or in which a pressure sensor is provided to measure the gas flow rate.

25

9. A device according to one claim 2 in which a passage for the sub-quantities of the smoking product is provided through which the gravitationally descending sub-quantities pass and cross the carrier gas stream roughly perpendicular or antiparallel to its flow direction.

30

10. A device according to one of the previous claims in which the housing adjacent to the heating appliance is transparent so that the heat glow is visible through the housing and/or

35

that at least one electrical light is provided which is activated with the heating appliance.

11. A device according to one of the previous claims wherein within the suck-off channel on the smoker's side at least one portion of contractable cross-section is provided, especially being arranged as an elastomer part being deformable by finger pressure.

12. A device smoking tobacco or another smoking product or for the inhalation of aerosols released by the heating of an aerosol releasing substance, said device substantially as described herein with reference to Figs. 1 and 2 or any one of Figs. 3 to 7 of the accompanying drawings.

2
3
4
5
6
7
8
9
10
11
12

13
14
15
16
17
18
19
20
21
22
23

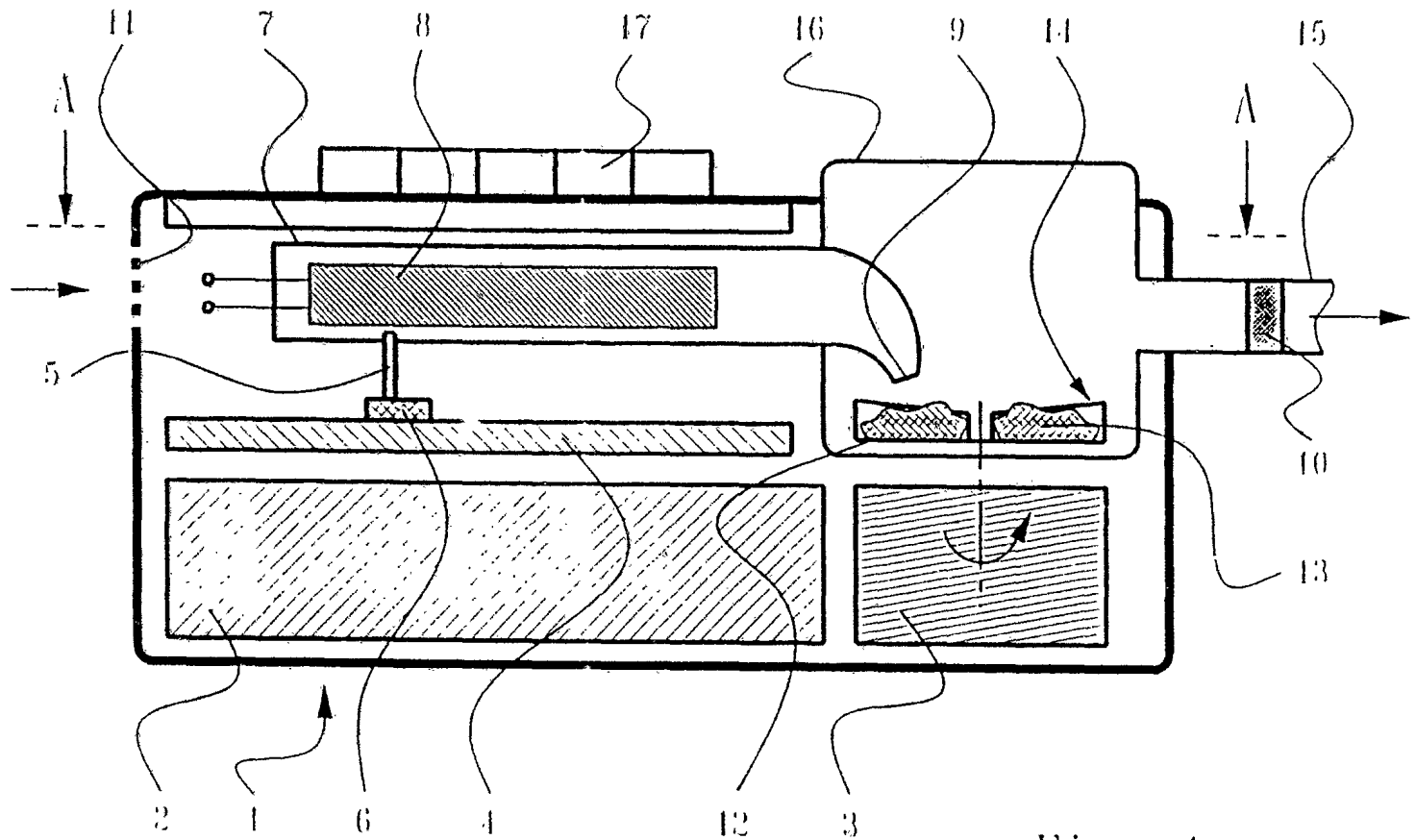

Fig. 1

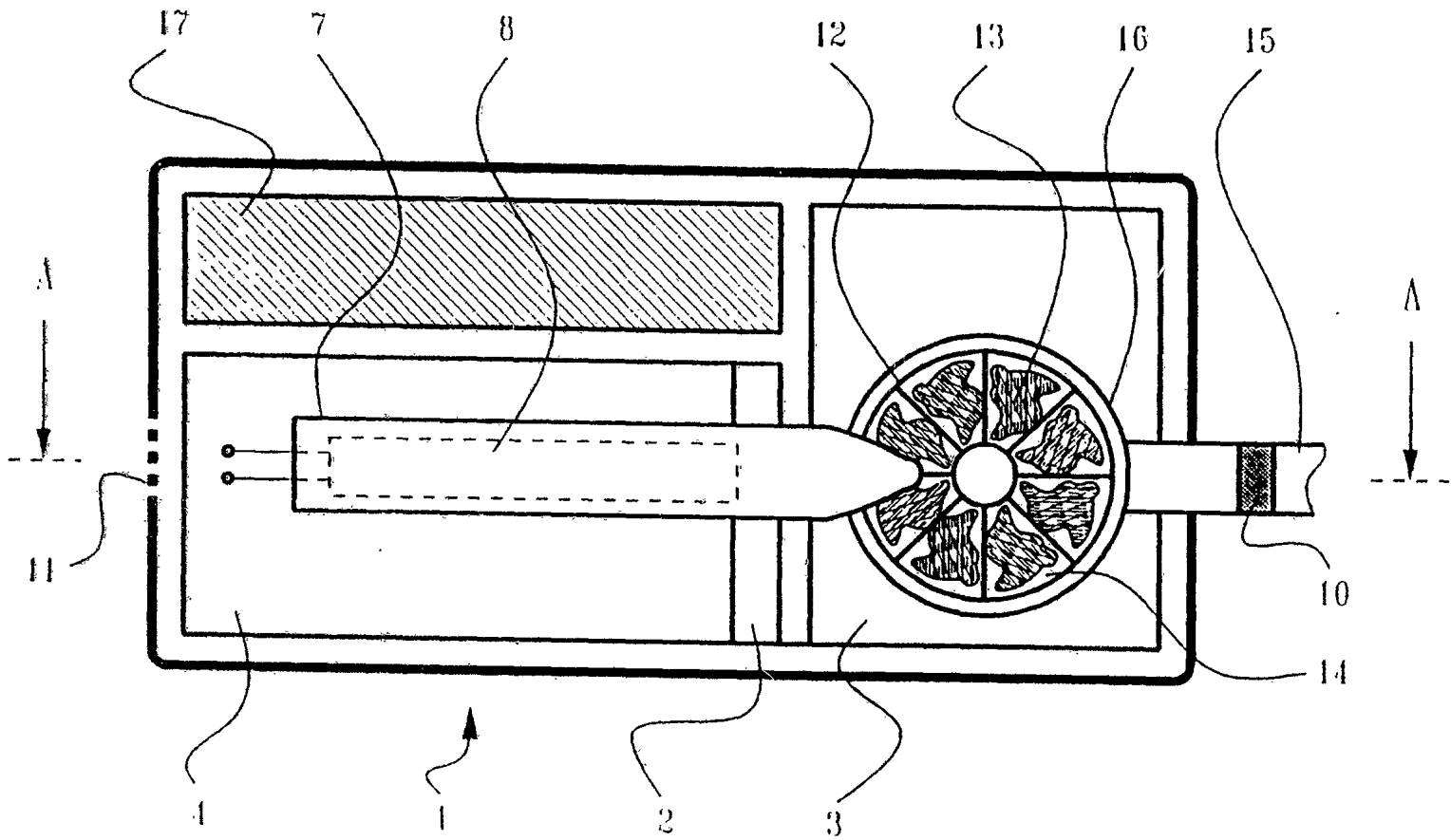

Fig. 2

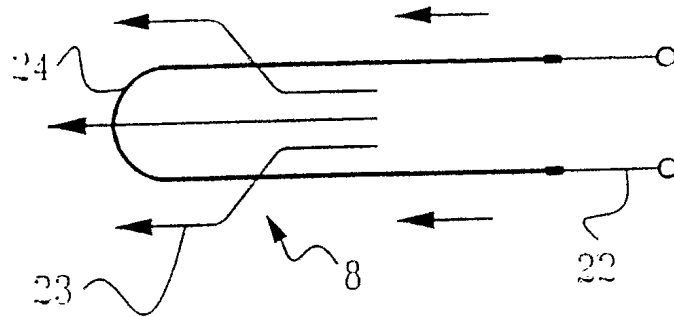

Fig. 3

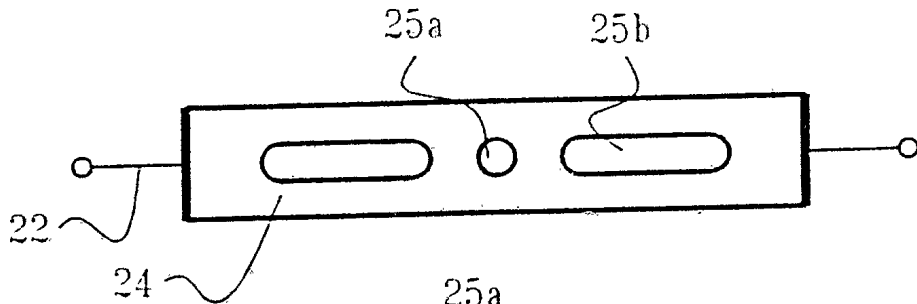

Fig. 3a

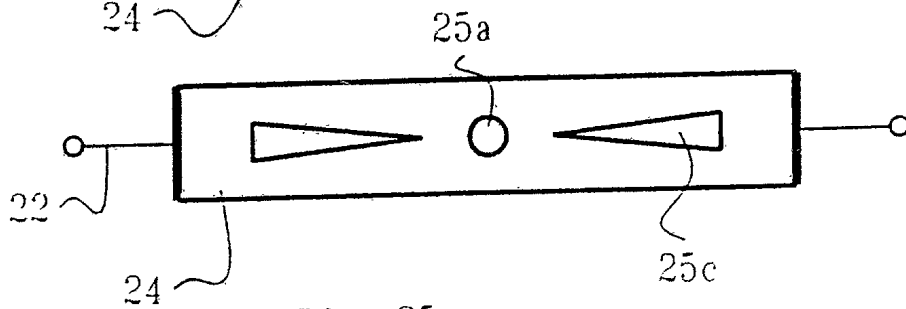

Fig. 3b

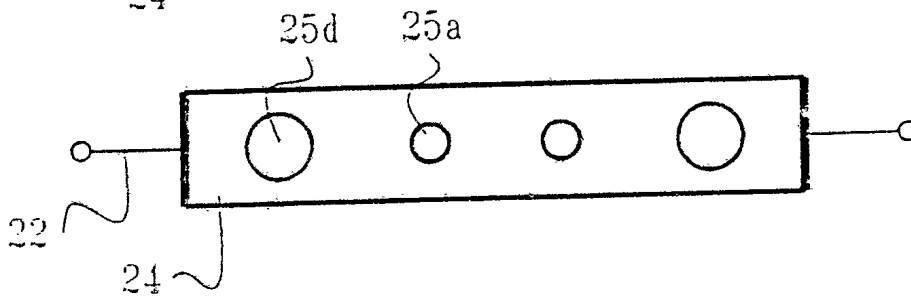

Fig. 3c

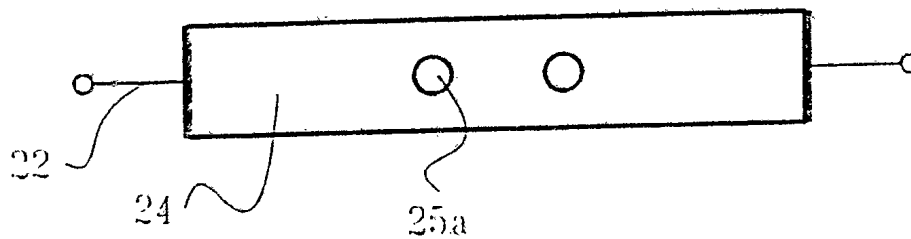

Fig. 3d

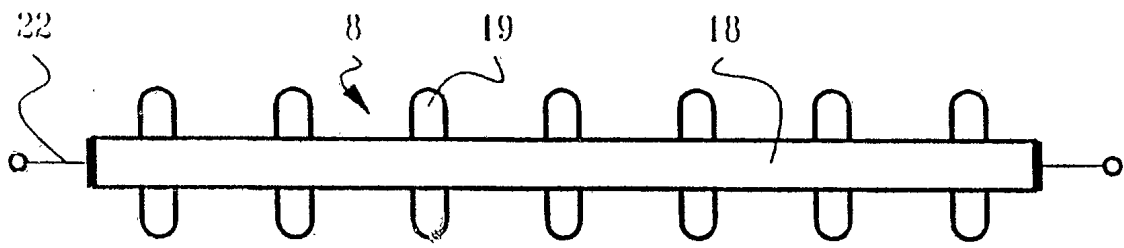

Fig. 3e

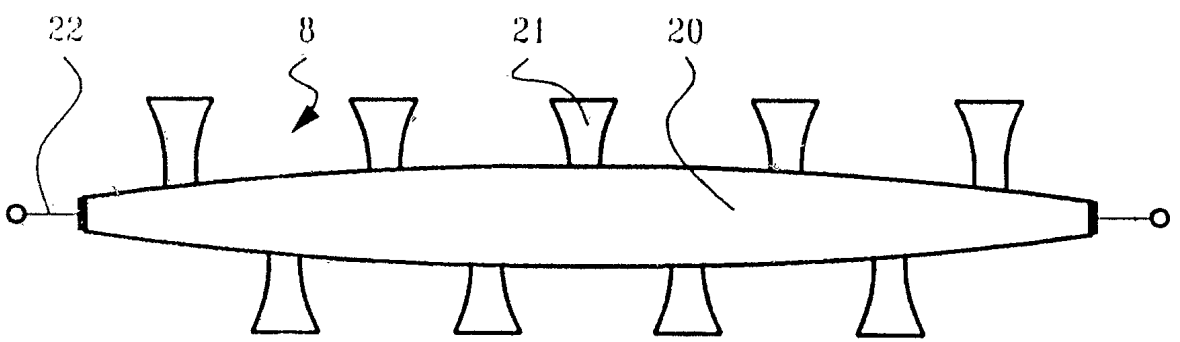

Fig. 3f

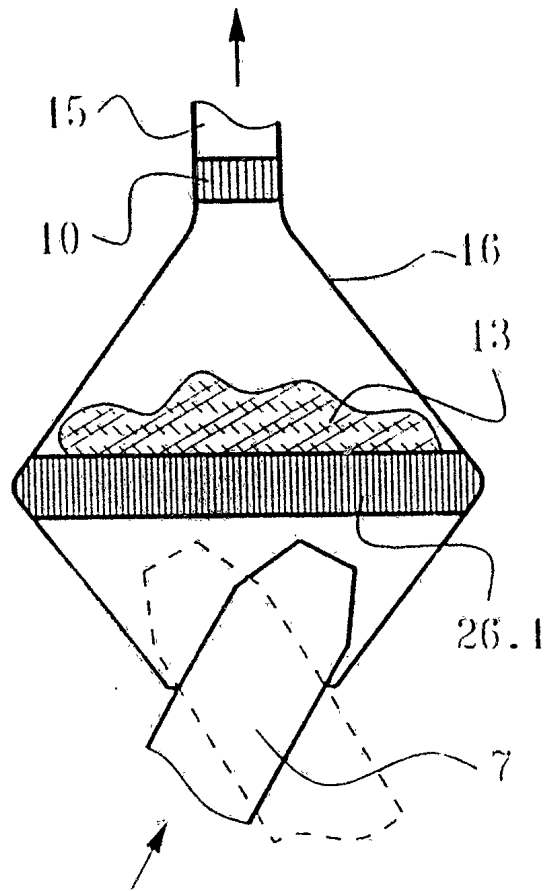

Fig. 4

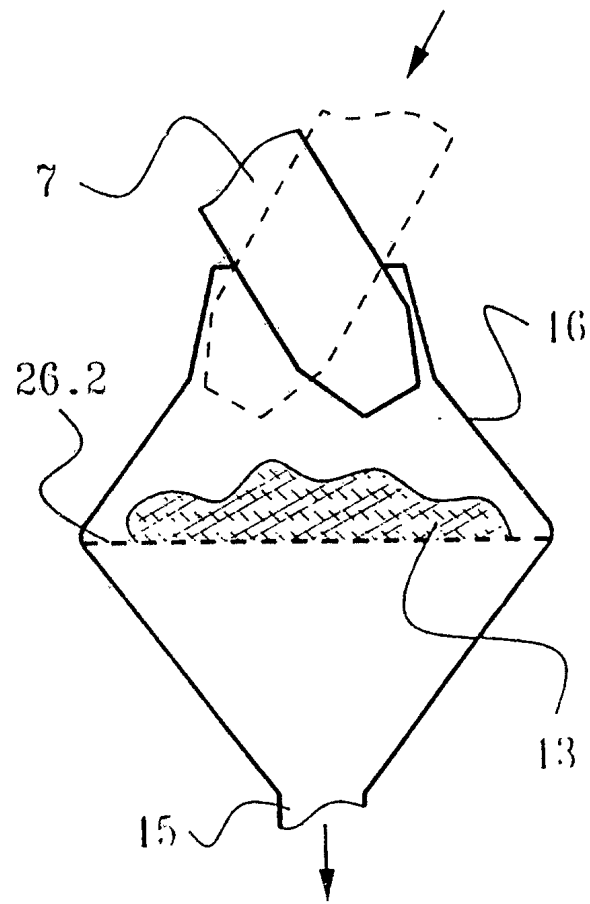

Fig. 5

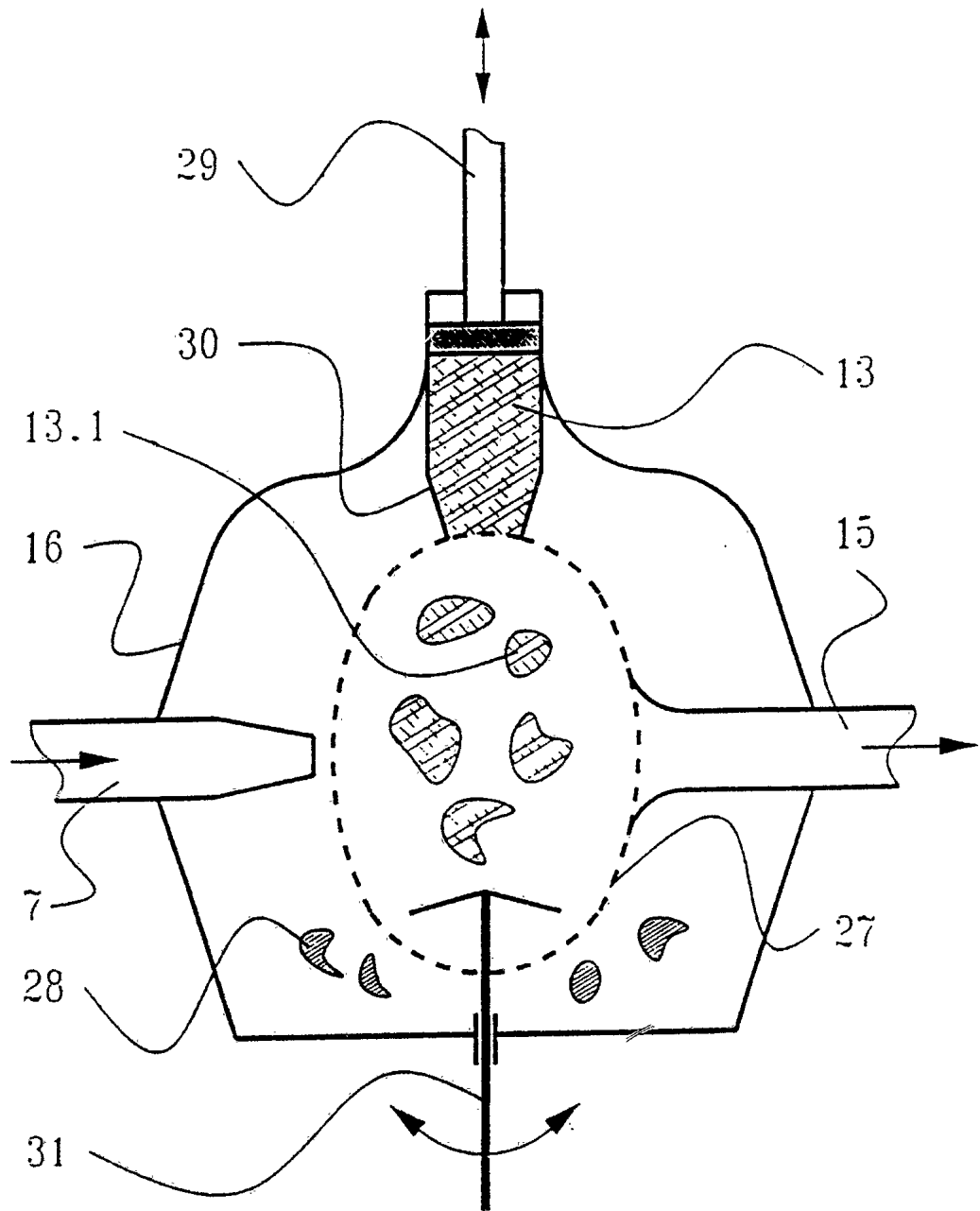

Fig. 6

7/7

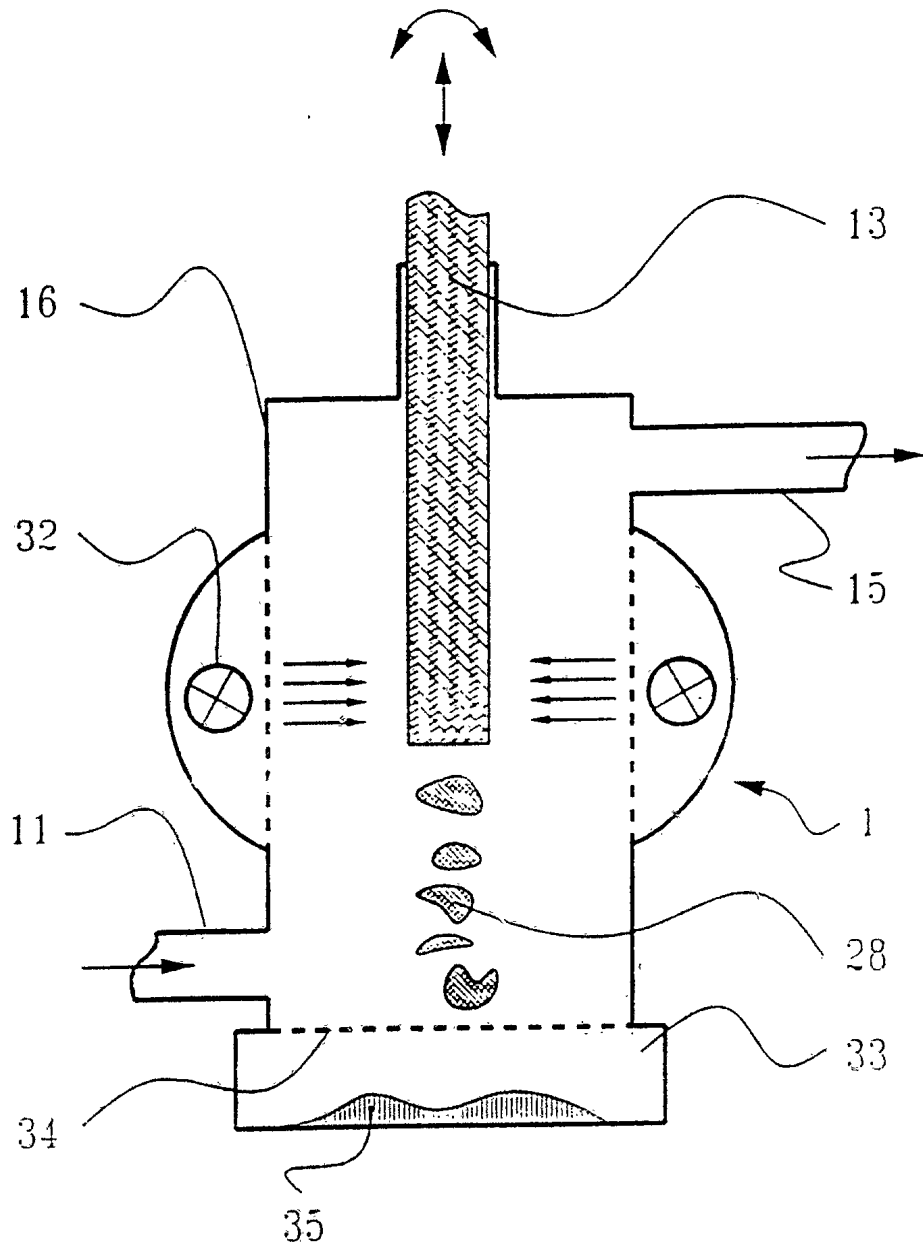

Fig. 7

INTERNATIONAL SEARCH REPORT

 Inter national Application No
 PCT/DE 94/00991

 A. CLASSIFICATION OF SUBJECT MATTER
 IPC 6 A24F47/00

According to International Patent Classification (IPC) or to both national classification and IPC

B. FIELDS SEARCHED

 Minimum documentation searched (classification system followed by classification symbols)
 IPC 6 A24F A61M

Documentation searched other than minimum documentation to the extent that such documents are included in the fields searched

Electronic data base consulted during the international search (name of data base and, where practical, search terms used)

C. DOCUMENTS CONSIDERED TO BE RELEVANT

Category*	Citation of document, with indication, where appropriate, of the relevant passages	Relevant to claim No.
A	GB,A,526 678 (HEADLAND) 24 September 1940 see the whole document ---	1-3
A	DE,U,92 18 005 (MIELORDT) 19 May 1993 cited in the application see the whole document ---	1
A	US,A,4 141 369 (BURRUSS) 27 February 1979 see the whole document ---	1
A	US,A,5 095 921 (LOSEE) 17 March 1992 see column 3, line 46 - column 5, line 35; figures 1,2 ---	1
	-/--	

 Further documents are listed in the continuation of box C.

 Patent family members are listed in annex.

* Special categories of cited documents :

- *A* document defining the general state of the art which is not considered to be of particular relevance
- *E* earlier document but published on or after the international filing date
- *L* document which may throw doubts on priority claim(s) or which is cited to establish the publication date of another citation or other special reason (as specified)
- *O* document referring to an oral disclosure, use, exhibition or other means
- *P* document published prior to the international filing date but later than the priority date claimed

- *T* later document published after the international filing date or priority date and not in conflict with the application but cited to understand the principle or theory underlying the invention
- *X* document of particular relevance; the claimed invention cannot be considered novel or cannot be considered to involve an inventive step when the document is taken alone
- *Y* document of particular relevance; the claimed invention cannot be considered to involve an inventive step when the document is combined with one or more other such documents, such combination being obvious to a person skilled in the art.
- *&* document member of the same patent family

Date of the actual completion of the international search

5 December 1994

Date of mailing of the international search report

25. 01. 95

Name and mailing address of the ISA

 European Patent Office, P.B. 5818 Patentlaan 2
 NL - 2280 HV Rijswijk
 Tel. (+ 31-70) 340-2040, Tx. 31 651 epo nl,
 Fax (+ 31-70) 340-3016

Authorized officer

RIEGEL, R

INTERNATIONAL SEARCH REPORT

International Application No
PCT/DE 94/00991

C.(Continuation) DOCUMENTS CONSIDERED TO BE RELEVANT

Category	Citation of document, with indication, where appropriate, of the relevant passages	Relevant to claim No.
A	EP,A,0 358 002 (R.J. REYNOLDS TOBACCO COMPANY) 14 March 1990 cited in the application see column 9, line 1 - column 13, line 58; figure 1 ---	1
A	US,A,2 104 266 (MCCORMICK) 4 January 1938 see the whole document -----	1

INTERNATIONAL SEARCH REPORT

Information on patent family members

International Application No
PCT/DE 94/00991

Patent document cited in search report	Publication date	Patent family member(s)	Publication date
GB-A-526678		NONE	
DE-U-9218005	19-05-93	NONE	
US-A-4141369	27-02-79	NONE	
US-A-5095921	17-03-92	AT-T- 108311	15-07-94
		AU-B- 642460	21-10-93
		AU-A- 7013991	21-05-92
		CA-A- 2035761	20-05-92
		EP-A- 0488488	03-06-92
		ES-T- 2057751	16-10-94
		TR-A- 25275	01-01-93
		US-A- 5179966	19-01-93
EP-A-0358002	14-03-90	US-A- 4947874	14-08-90
		CN-A- 1045691	03-10-90
		JP-A- 2124082	11-05-90
US-A-2104266		NONE	