

(12) INTERNATIONAL APPLICATION PUBLISHED UNDER THE PATENT COOPERATION TREATY (PCT)

(19) World Intellectual Property  
Organization  
International Bureau



(10) International Publication Number  
**WO 2019/094782 A1**

(43) International Publication Date  
16 May 2019 (16.05.2019)

(51) International Patent Classification:

*A61B 17/22* (2006.01)      *A61F 13/45* (2006.01)  
*A61F 2/06* (2013.01)      *A61M 5/14* (2006.01)  
*A61F 2/88* (2006.01)      *A61M 25/10* (2013.01)  
*A61F 2/90* (2013.01)

Published:

— with international search report (Art. 21(3))

(21) International Application Number:

PCT/US2018/060115

(22) International Filing Date:

09 November 2018 (09.11.2018)

(25) Filing Language:

English

(26) Publication Language:

English

(30) Priority Data:

15/808,649      09 November 2017 (09.11.2017)      US

(71) Applicant: **PEBBLE HILL PARTNERS, LLC** [US/US];

775 Pebble Hill Road, Doylestown, PA 18901 (US).

(72) Inventor: **GREEN, Nicholas**; 19785 Castlewood Dr,

Jupiter, FL 33458 (US).

(74) Agent: **SHARAREH, Shahnam** et al.; Fox Rothschild

LLP, 997 Lenox Drive, Lawrenceville, NJ 08648-2311 (US).

(81) Designated States (*unless otherwise indicated, for every*

*kind of national protection available*): AE, AG, AL, AM, AO, AT, AU, AZ, BA, BB, BG, BH, BN, BR, BW, BY, BZ, CA, CH, CL, CN, CO, CR, CU, CZ, DE, DJ, DK, DM, DO, DZ, EC, EE, EG, ES, FI, GB, GD, GE, GH, GM, GT, HN, HR, HU, ID, IL, IN, IR, IS, JO, JP, KE, KG, KH, KN, KP, KR, KW, KZ, LA, LC, LK, LR, LS, LU, LY, MA, MD, ME, MG, MK, MN, MW, MX, MY, MZ, NA, NG, NI, NO, NZ, OM, PA, PE, PG, PH, PL, PT, QA, RO, RS, RU, RW, SA, SC, SD, SE, SG, SK, SL, SM, ST, SV, SY, TH, TJ, TM, TN, TR, TT, TZ, UA, UG, US, UZ, VC, VN, ZA, ZM, ZW.

(84) Designated States (*unless otherwise indicated, for every*

*kind of regional protection available*): ARIPO (BW, GH, GM, KE, LR, LS, MW, MZ, NA, RW, SD, SL, ST, SZ, TZ, UG, ZM, ZW), Eurasian (AM, AZ, BY, KG, KZ, RU, TJ, TM), European (AL, AT, BE, BG, CH, CY, CZ, DE, DK, EE, ES, FI, FR, GB, GR, HR, HU, IE, IS, IT, LT, LU, LV, MC, MK, MT, NL, NO, PL, PT, RO, RS, SE, SI, SK, SM, TR), OAPI (BF, BJ, CF, CG, CI, CM, GA, GN, GQ, GW, KM, ML, MR, NE, SN, TD, TG).

(54) Title: BASKET FOR A CATHETER DEVICE

(57) Abstract: The present disclosure relates to a basket for a catheter designed to be deployed in complex vasculature to optimally treat vascular and arterial disease conditions such as blood clots, blood emboli, and deep vein thrombosis. The basket may comprise a shaft with a plurality of cuts along a portion of its length to form a plurality of tines that provide support for a plurality of porous tubes to form the limbs of the basket. The limbs of the basket expand radially away from the longitudinal axis of the basket when the longitudinal length of the basket is reduced. The limbs may also be connected to a drug delivery system, and in this manner, baskets of the present disclosure allow for the use of both mechanical and pharmaceutical means of thrombolysis.



WO 2019/094782 A1

**BASKET FOR A CATHETER DEVICE**

**CROSS-REFERENCE TO RELATED APPLICATIONS**

This application claims priority to U.S. Patent Application No. 15/808,649, filed Nov. 9, 2017, the disclosure of which is incorporated herein by reference in its entirety.

**FIELD OF THE INVENTION**

The present invention relates to mechanically deployable basket features for a catheter device, infusion catheters, and methods of treatment of pulmonary embolism and deep vein thrombosis.

**BACKGROUND OF THE INVENTION**

Conventional methods for catheter-directed thrombolysis involves infusing a clot dissolving medication via a single lumen infusion catheter, which is typically much smaller in diameter than the vessel in which it is placed. Additionally, because the clot has reduced or stopped the blood flow through the vessels, dispersion of the clot-dissolving medication is impaired. Catheter-directed thrombolysis devices may additionally employ expandable baskets to mechanically open a blood clot, but these expandable baskets typically function best in straight vessels and are not well adapted to the curved vascular. For example, in the case of a pulmonary embolism and the anatomy of the pulmonary artery, large blood clots are often lodged deep in the greater curvature of the artery and are difficult to treat. Concurrent monitoring of important vital signs within the occluded vessel, such as blood pressure, is also not possible during deployment of current catheter-directed thrombolysis devices.

What is needed in the art is an improved basket and infusion catheter that addresses the above limitations.

**SUMMARY OF THE INVENTION**

The present invention addresses the need mentioned above by providing deployable baskets, infusion catheters and methods for the treatment of thrombus in a blood vessel.

In one aspect, the present disclosure provides a basket for an infusion catheter comprising a shaft comprising a wall with an inner surface and an outer surface and a lumen extending between a distal end and a proximal end and defining a longitudinal axis, wherein a plurality of cuts along at least a portion of the shaft between the inner and outer surface of the wall form a plurality of tines, a plurality of tubes, each tube comprising a wall with an inner

surface and an outer surface and a lumen extending between a distal end and a proximal end, wherein each of the plurality of tines of the shaft are disposed in the lumen of each of the plurality of tubes to form a plurality of limbs, and wherein the distal end of each of the plurality of limbs are attached and the proximal end of each of the plurality of limbs are  
5 attached.

In some embodiments, the present basket for an infusion catheter comprising a shaft comprising a wall with an inner surface and an outer surface and a lumen extending between a distal end and a proximal end and defining a longitudinal axis, wherein a plurality of helical cuts along a portion of the shaft between the inner and outer surface of the wall form a  
10 plurality of tines; wherein the proximal end of the shaft is uncut; a plurality of tubes, each tube comprising a wall with an inner surface and an outer surface and a lumen extending between a distal end and a proximal end; wherein the plurality of tubes are melted together and to the outside of the shaft at the uncut proximal end of the shaft; wherein each of the plurality of tines of the shaft are disposed in the lumen of each of the plurality of tubes to  
15 form a plurality of limbs; wherein the plurality of tines independently support the limbs without interconnection of tines between the proximal and distal end of the tines; and wherein the distal end of each of the plurality of limbs are attached together.

In some embodiments, the limbs of the basket deploy from a first position to a second position when the longitudinal length of the basket is reduced.

20 In some embodiments, the limbs of the basket are in a closed state in the first position. In some embodiments, the limbs of the basket expand radially away from the longitudinal axis when the longitudinal length of the basket is reduced.

In some embodiments, the shaft comprises a shape memory material. In some embodiments, the shape memory material is a nickel-titanium nitinol alloy.

25 In some embodiments, the plurality of cuts are formed by laser cutting. In some embodiments, the plurality of cuts are helical and have a rotation of at least 360 degrees over the length of the deployable infusion basket. In some embodiments, the plurality of helical cuts have a rotation of at least 450 degrees over the length of the deployable infusion basket. In some embodiments, the plurality of cuts do not extend to the proximal end of the shaft.

30 In some embodiments, each of the plurality of tubes is porous. In some embodiments, each of the plurality of tubes comprises a plurality of infusion ports extending between the inner surface and outer surface of the wall of the tube. In some embodiments, the infusion ports are holes having diameters between 0.001 and 0.006 inches.

In some embodiments, the basket is between three and eight inches in length. In some embodiments, the basket is about six inches in length.

In some embodiments, the basket further comprises a fiber optic material disposed within the lumen of at least one of the plurality of tubes.

5 In another aspect, the present disclosure provides a catheter comprising a basket comprising a shaft comprising a wall with an inner surface and an outer surface and a lumen extending between a distal end and a proximal end and defining a longitudinal axis, wherein a plurality of helical cuts along at least a portion of the shaft between the inner and outer surface of the wall form a plurality of tines, a plurality of tubes, each tube comprising a wall  
10 with an inner surface and an outer surface and a lumen extending between a distal end and a proximal end, wherein the each of the plurality of tines of the shaft are disposed in the lumen of each of the plurality of tubes to form a plurality of limbs, and wherein the distal end of each of the plurality of limbs are attached and the proximal end of each of the plurality of limbs are attached, an inner shaft comprising a wall with an inner surface and an outer  
15 surface and a lumen extending between a distal end and a proximal end, wherein the inner elongate shaft is disposed coaxially within the lumen of the shaft and is attached to the distal end of the basket, an outer shaft comprising a wall with an inner surface and an outer surface and a lumen extending between a distal end and a proximal end, wherein the outer shaft is disposed coaxially around the inner shaft to form a fluid compartment between the inner  
20 surface of the outer shaft and the outer surface of the inner shaft, and wherein the proximal end of the limbs of the basket are connected to the fluid compartment.

In some embodiments, the connection between the proximal end of the limbs of the basket and the fluid compartment comprises a seal disposed between the inner shaft and the proximal end of the plurality of limbs.

25 In some embodiments, the limbs of the basket deploy from a first position to a second position when the inner shaft is moved in a proximal direction. In some embodiments, the limbs of the basket expand radially away from the longitudinal axis when the inner shaft is moved in a proximal direction. In some embodiments, each of the plurality of tubes comprises a plurality of infusion ports extending between the inner surface and outer surface  
30 of the wall of the eluting arm. In some embodiments, the catheter further comprises a fiber optic material disposed within the lumen of the inner shaft or at least one of the plurality of tubes. In some embodiments, the basket further comprises an irradiation source.

Also provided herein is a method of catheter-directed thrombolysis, the method comprising providing a catheter comprising a basket comprising a shaft comprising a wall

with an inner surface and an outer surface and a lumen extending between a distal end and a proximal end and defining a longitudinal axis, wherein a plurality of helical cuts along at least a portion of the shaft between the inner and outer surface of the wall form a plurality of tines, a plurality of tubes, each tube comprising a wall with an inner surface and an outer  
5 surface and a lumen extending between a distal end and a proximal end, wherein each of the plurality of tubes comprises a plurality of infusion ports extending between the inner surface and outer surface of the wall of the tubes, wherein the each of the plurality of tines of the shaft are disposed in the lumen of each of the plurality of tubes to form a plurality of limbs, and wherein the distal end of each of the plurality of limbs are attached and the proximal end  
10 of each of the plurality of limbs are attached, an inner shaft comprising a wall with an inner surface and an outer surface and a lumen extending between a distal end and a proximal end, wherein the inner elongate shaft is disposed coaxially within the lumen of the shaft and is attached to the distal end of the basket, an outer shaft comprising a wall with an inner surface and an outer surface and a lumen extending between a distal end and a proximal end, wherein  
15 the outer shaft is disposed coaxially around the inner shaft to form a fluid compartment between the inner surface of the outer shaft and the outer surface of the inner shaft, and wherein the proximal end of the limbs of the basket are connected to the fluid compartment; advancing the infusion basket at least partially through a thrombus within a vessel in a first position; deploying the basket to a second position; and simultaneously infusing a therapeutic  
20 fluid through the infusion ports of the limbs of the basket.

In some embodiments, the limbs of the basket are in a closed state in the first position and radially expand away from the longitudinal axis in the second position. In some embodiments, a fluid opening through the thrombus is created when deploying the basket to the second position.

25 In some embodiments, the therapeutic fluid comprises a thrombolytic agent.

In some embodiments, the method further comprises delivering light energy to the thrombus. In some embodiments, the light energy is delivered to the thrombus through a fiber optic material disposed within the lumen of the inner shaft or at least one of the plurality of tubes. In some embodiments, the light energy is delivered to the thrombus simultaneously  
30 with the infusion of the therapeutic fluid.

The details of one or more embodiments of the invention are set forth in the description below. Other features, objectives, and advantages of the invention will be apparent from the description and from the claims.

### BRIEF DESCRIPTION OF THE FIGURES

The accompanying drawings, which are incorporated herein and constitute part of this specification, illustrate the presently preferred embodiments of the invention, and, together with the general description above and the detailed description given below, serve to explain the features of the invention. In the drawings:

**Figure 1** shows a frame of an exemplary basket in a first (A) and a second position (B), and an assembled basket (C), according to an embodiment of the present disclosure.

**Figure 2** shows a photograph of a frame before assembly into a basket, according to an embodiment of the present disclosure.

**Figure 3** shows a method for creating uniform flow along the length of an exemplary limb of a basket, according to an embodiment of the present disclosure.

**Figure 4** shows an exemplary internal frame in an expanded state within (A) a straight vessel, (B) a curved vessel, and (C) a vessel mimicking the greater curvature of the pulmonary artery.

**Figure 5** shows exemplary frames with different spiral pitches.

**Figure 6** shows an exemplary basket with fiber optic components, according to an embodiment of the present disclosure.

**Figure 7** shows an exemplary infusion catheter device in an open or expanded position (A) and closed position (B) in a lateral view, and in an open or expanded position in an axial view (C), according to an embodiment of the present disclosure.

**Figure 8** shows a view of the seal assembly of an exemplary infusion catheter device, according to an embodiment of the present disclosure.

**Figure 9** shows an exemplary infusion catheter device, according to an embodiment of the present disclosure.

### DETAILED DESCRIPTION OF THE INVENTION

The present invention will now be described more fully hereinafter. However, many modifications and other embodiments of the present invention set forth herein will come to mind to one skilled in the art to which the invention pertains having the benefit of the teachings presented in the foregoing descriptions. Therefore, it is to be understood that the present invention is not to be limited to the specific embodiments disclosed and that modifications and other embodiments are intended to be included within the scope of the appended claims.

Reference throughout this specification to features, advantages, or similar language does not imply that all of the features and advantages that may be realized with the present disclosure should be or are in any single embodiment of the disclosure. Rather, language referring to the features and advantages is understood to mean that a  
5 specific feature, advantage, or characteristic described in connection with an embodiment is included in at least one embodiment of the present disclosure. Thus, discussions of the features and advantages, and similar language, throughout the specification may, but do not necessarily, refer to the same embodiment.

Furthermore, the described features, advantages and characteristics of the  
10 disclosure may be combined in any suitable manner in one or more embodiments. One skilled in the relevant art will recognize, in light of the description herein, that the disclosure can be practiced without one or more of the specific features or advantages of a particular embodiment. In other instances, additional features and advantages may be recognized in certain embodiments that may not be present in all embodiments of the  
15 disclosure.

Reference throughout this specification to “one embodiment,” “an embodiment,” or similar language means that a particular feature, structure, or characteristic described in connection with the indicated embodiment is included in at least one embodiment of the present disclosure. Thus, the phrases “in one embodiment”, “in an embodiment”, and  
20 similar language throughout this specification may, but do not necessarily, all refer to the same embodiment.

In one aspect, the present disclosure relates to a mechanically deployable basket for an infusion catheter. A basket of the present disclosure is specifically designed to be  
25 deployed in complex vasculature to optimally treat vascular and arterial disease conditions such as blood clots, blood emboli, and deep vein thrombosis. The basket may comprise a shaft with a plurality of cuts along a portion of its length to form a plurality of tines that provide support for a plurality of porous tubes to form the limbs of the basket. The ends of the limbs may be attached, such that the limbs of the basket expand radially away from the longitudinal axis of the basket when the longitudinal length of the basket is reduced. The  
30 limbs may also be connected to a drug delivery system, and in this manner, baskets of the present disclosure allow for the use of both mechanical and pharmaceutical means of thrombolysis. Also provided herein are infusion catheters comprising a basket of the present disclosure. In another aspect, the present disclosure relates to methods of treatment and methods of catheter-directed thrombolysis.

As used herein, the singular form “a”, “an”, and “the” include plural references unless the context clearly dictates otherwise. Unless defined otherwise, all technical and scientific terms used herein have the same meanings as commonly understood by one of ordinary skill in the art.

5 As used herein, the terms “about” and “approximately” may be used interchangeably and is meant to encompass variations of  $\pm 20\%$ ,  $\pm 10\%$ ,  $\pm 5\%$ ,  $\pm 1\%$ , and  $\pm 0.1\%$  from the specified value, as such variations are appropriate.

As used herein, the term “communicate” and “communication” include, but are not limited to, the connection of fluid system elements, either directly or remotely, enabling fluid  
10 interface among and between said elements.

As used herein, the term “connectable” or “connection” refers to being able to be joined together for purposes including, but not limited to, allowing a flow of fluid. The term “connectable” can refer to being able to be joined together temporarily or permanently.

As used herein, the term “drug delivery system” refers to a device that enables the  
15 introduction of a therapeutic substance into a patient in a controlled manner. These may include, *e.g.*, infusion pumps and other necessary components.

As used herein, the term “helical” refers to a helix or other three-dimensional curve that is disposed around the circumference of a cylinder, cone, or similar structure. The “pitch” of a helix or helical curve refers to the longitudinal distance over which the helix or  
20 helical curve completes a single revolution ( $360^\circ$ ). For example, a pitch of three inches means that the helix completes one turn every three inches, while a pitch of six inches means that the helix completes one turn every six inches. A helix or helical curve may also be described by the number of degrees of rotation that the helix or helical curve completes from  
25 its starting point to its end point. For example, a  $360^\circ$  helix or helical curve completes a single revolution around the circumference over its length, while a  $450^\circ$  helix completes one-and-a-quarter turns and a  $540^\circ$  helix completes one-and-a-half turns over its length.

As used herein, the terms “luer connector” and “luer adapter” refer to adapters or connectors conforming to International Standards Organization (ISO) standards 594-2.

As used herein, a “patient” or “subject” is a member of any animal species, preferably  
30 a mammalian species, optionally a human. The subject can be an apparently healthy individual, an individual suffering from a disease, or an individual being treated for a disease.

As used herein, the term “shape memory material” may comprise a shape memory alloy or shape memory polymer. These materials are characterized by pseudoelasticity, or superelasticity, which is a reversible elastic response to an applied stress that allows the

material to return from a temporary deformed state to a permanent original shape after the applied stress or force is removed. Exemplary shape-memory alloys include copper-aluminum-nickel alloys and nickel-titanium (nitinol) alloys.

As used herein, a “therapeutic fluid” is a fluid that that may be administered to a  
5 patient through a basket or catheter of the present disclosure. These “therapeutic fluids” may be inert and administered in conjunction with other therapeutic techniques and methods disclosed herein, or may comprise one or more therapeutic agents. A “therapeutic agent” (or “pharmaceutical”, “pharmaceutically active agent”, “drug” or other related term which may be used interchangeably herein) refers to an agent that that may be used for the treatment of a  
10 disease or condition (*i.e.*, the prevention of a disease or condition, the reduction or elimination of symptoms associated with a disease or condition, or the substantial or complete elimination of a disease or condition). These agents may include thrombolytic agents that are used to dissolve blood clots including, but not limited to, fibrinolytic such as Streptokinase, Urokinase, Anistreplase, Recombinant tissue plasminogen activators, or  
15 staphylokinase, or other thrombolytic agents as known to those of ordinary skill in the art.

As used herein, the terms “treating” and “treatment” refer to the management and care of a patient having a pathology or condition by administration of one or more therapy contemplated by the present disclosure. Treating also includes administering one or more methods of the present disclosure or using any of the systems, devices or compositions of the  
20 present disclosure in the treatment of a patient. As used herein, “treatment” or “therapy” refers to both therapeutic treatment and prophylactic or preventative measures. “Treating” or “treatment” does not require complete alleviation of signs or symptoms, does not require a cure, and includes protocols having only a marginal or incomplete effect on a patient.

As used herein, the term “vessel” refers to a bodily passage or tract through which a  
25 basket of the present disclosure may be disposed. This may include, *e.g.*, the circulatory system, the digestive tract, urinary tract, biliary tract, or other passages in the body.

Referring now to **FIG. 1**, an embodiment of a basket of the present disclosure is provided. As shown in **FIG. 1A**, the deployable basket comprises a frame **110**. Frame **110** comprises a hollow tube or shaft with a wall with an inner surface and an outer surface and a  
30 lumen extending from its proximal end **101** to its distal end **102** and defining a longitudinal axis. The wall of the shaft has a plurality of cuts from the outer surface of the wall to the inner surface of the wall and extending longitudinally from an end, *e.g.*, the distal end, of the shaft along a portion of its length to provide a plurality of tines **115**, the ends of which are free and unattached to one another. The cuts do not extend the full length of the shaft, but

rather the other end, *e.g.*, the proximal end, is uncut in order to maintain a solid attachment point between each of the plurality of tines **115**. A photograph of a frame **110** with a plurality of tines **115** is shown in **FIG. 2**. As can be seen, cuts extend from the left end of the shaft to form tines **115**, while the right end of the shaft remains whole. The free ends of the tines **115** may be permanently or temporarily attached together to prevent movement of the free ends, particularly in a radial direction away from the longitudinal axis. For example, as shown in **FIG. 1A**, a cap **116** may be placed over the free ends of tines **115**. With the ends of the tines joined, the frame **110** of the basket may be deployed from a closed state to an expanded state by reducing the longitudinal length  $L$  of the frame **110**, *i.e.*, by moving the proximal and distal ends closer together along the longitudinal axis, as shown in **FIG. 1B**. In some embodiments, the tines **115** of frame **110** expand radially away from the longitudinal axis when the longitudinal length of the frame is reduced.

A fully assembled basket **100** is shown in **FIG. 1C**, and it further comprises a plurality of tubes **120** disposed around each of the tines **115**. The tubes may comprise a wall with an inner surface and an outer surface and a lumen extending between a distal end and a proximal end. In some embodiments, the tubes may be slipped over the free ends of tines **115** before the ends of the tines are joined. Together, the tines **115** of frame **110** and tubes **120** form the limbs of the basket **100** of the present disclosure. The free ends of the limbs may be permanently or temporarily attached to each other by joining or securing the free ends of tines **115**, the tubes **120**, or both. In some embodiments, the free ends of the limbs are secured by melting or gluing the ends of tubes **120** together. A cap **140** may be placed over the free ends of the limbs. It should be understood that, if the tines **115** are disposed within the lumens of tube **120**, securing the free ends of tubes **120** together to prevent radial movement away from longitudinal axis of the basket **100** would likewise secure the free ends of tines **115**. As discussed above, once the free ends of the tines **115** are joined, either directly or by securing the ends of tubes **120**, basket **100** may be deployed to an expanded state by reducing its longitudinal length. In this way, the frame **110** provides the support for the tubes **120** and its structure dictates the manner in which the limbs of the basket **100**. In some embodiments, the limbs of basket **100** expand radially away from the longitudinal axis when its longitudinal length is reduced. In this way, a basket of the present disclosure is able to mechanically open a passageway through an occluded vessel by expanding the limbs of basket **100** while the basket **100** is disposed within a thrombus.

Each of the tube **120** may be porous and comprise a plurality of ports **121** between in the inner and outer surface of the walls of the tubes **120**, fluidly connecting the internal

lumens of the tubes **120** to the exterior. The ends of one, multiple, or all of tubes **120** may be fluidly connected to a drug delivery system through, *e.g.*, a catheter shaft, and the porosity of the tubes **120** allow a therapeutic to be delivered through the basket **100**. The number, size, and orientation of the ports **121** may be adjusted to provide a desired infusion rate and to  
5 ensure uniform dispersion of the therapeutic fluid along the entire length of the basket **100**. The ports may be evenly distributed along the length of tubes **120**, or may be non-uniform. The ports may also be placed in a manner to provide directional infusion. For example, the ports may be placed on the side of the wall of tubes **120** that is further away from the central longitudinal axis of basket **100**, *i.e.*, the portion of the wall of tubes **120** that would be in  
10 contact with a clot when deployed. In this way, a basket **100** of the present disclosure is able to therapeutically dissolve a thrombus through infusion. In some embodiments, the ports **121** may be laser-drilled holes having diameters between 0.001 and 0.010 inches, with between 5 and 100 ports **121** per tube **120**. In some embodiments, a tube **120** may comprise 48 ports **121** that are sized between 0.001 and 0.006 inches. The design of the ports **121** may be  
15 matched with the input flow rate requirements of a drug delivery system that is connected to one, multiple, or all of the lumens of tubes **120**. By matching the flow-rates, the optimal backpressure within the tubes **120** can be created to release a therapeutic fluid in a uniform manner along their entire lengths.

In some embodiments, the basket may comprise an additional set of outer tubes **125**  
20 comprising a wall with an inner surface and an outer surface and a lumen extending between a distal end and a proximal end disposed around each of tubes **120**, as shown in **FIG. 3**, which depicts a single limb of the basket **100**. Outer tubes **125** may be sized such that a fluid compartment is formed between the inner surface of the wall of outer tubes **125** and the outer surface of the wall of tubes **120**. The proximal and distal ends of outer tubes **125** may be  
25 sealed against the proximal and distal ends of tubes **120** such that the formed fluid compartment is sealed at the proximal and distal ends. Outer tubes **125** may be porous and comprise a plurality of ports **126** between in the inner and outer surface of the walls of the outer tubes, similar to the plurality of ports **121** on tubes **120**. However, ports **126** may be sized and spaced such that the flow rate of a therapeutic fluid through ports **126** is less than  
30 the flow rate of the therapeutic fluid through ports **121**, *e.g.*, the cross sectional surface area of ports **126** is less than the surface area of ports **121**. In this way, fluid that flows through the lumen of a tube **120** and is emitted through ports **121** accumulates within the formed fluid compartment and distributes along the longitudinal length of the limb as it is emitted through ports **126**. Accordingly, even fluid distribution along the entire length of a limb is ensured.

In some embodiments, the ports **126** may be laser-drilled holes having diameters between 0.001 and 0.010 inches, with between 5 and 100 ports **126** per outer tube **125**.

The length of the basket **100** may be adjusted in order to provide the desired therapeutic benefits to the desired target location. In some embodiments, the basket **100** may be between two inches and eight inches in a closed state. In some embodiments, the basket **100** is approximately five inches in length in a closed state. However, as the length of the basket **100** is increased, its structural properties may be affected such that its thrombolytic performance is impaired. In such instances where a greater basket length is desired, one or more baskets **100** may be disposed adjacent to one another along the same longitudinal axis. In some embodiments, option ports **122** may be placed at the distal end **101** of the basket **100** to create a greater infusion length.

In some embodiments, the basket **100** may further comprise an optional distal catch protection basket **130** around the distal end of the basket **110**. This distal catch protection basket **130** may serve as a safety net by preventing large emboli fragments from embolizing to another part of the body. This may be of particular risk when the basket **100** is placed within a large artery, such as the pulmonary artery. A membrane of a soft, thin polymer would be attached to the outside of the limbs of basket **100** to provide a webbing between each of the limbs when the basket **100** is expanded. Once expanded, the webbing forms a parachute-shaped catch that can capture particles that may float downstream. In some embodiments, the distal catch protection basket **130** may comprise holes **131** sized to allow blood flow while still allowing the distal catch protection basket **130** to capture any debris that may be generated during use of the device. In addition to capturing these clots, the port **121** in tubes **120** at the distal end of the limbs, *i.e.*, within the distal catch protection basket **130** may be oriented inward towards the interior space of the distal catch protection basket **130**, thereby allowing maximum concentration of the infused therapeutic agent into the interior space to dissolve any captured fragments. Upon completion of the treatment, the basket can be retracted and removed from the patient, and any emboli that remains would be trapped in the distal catch protection basket **130** and could be safely removed from the body for examination. The distal catch protection basket **130** may be made of any suitable material, including, but not limited to, several varieties of polymers. For example, materials such as such as Nylon 12, polyethylene terephthalate (PET), polyether ether ketone (PEEK), polyurethanes, or a polyether block amide of various durometers. The exact durometer and thickness and hole **131** arrangement of the webbing of the distal catch protection basket **130** may be optimized for the specific size of basket **100** and desired application. The webbing

could be made by any standard balloon blowing methods as known to those of ordinary skill in the art, and then cut to fit the basket and attached, or may be casted directly on the basket end.

As discussed above, the frame **115** of basket **100** is constructed from a hollow shaft  
5 with a plurality of cuts through the wall of the shaft and extending from one end along a portion of the length of the shaft. These cuts determine the resulting structural shape of the basket **100**. In some embodiments, these cuts are made by a laser with a specific set of design patterns that have been optimally configured to provide open or expanded shapes to match vascular anatomy when in a deployed state. These cuts may be straight, *i.e.*, parallel to  
10 the longitudinal axis of the tube, helical, or both straight and helical. Each of the plurality of the cuts may be congruent, *i.e.*, identical in form, and translated around the circumference of the shaft such that they are parallel to one another along the longitudinal axis. That is, each of the tines **115** formed by the plurality of cuts may be a consistent width along their entire length. In other embodiments, each of the plurality of cuts may be incongruent, such that the  
15 tines **115** formed therefrom vary in width along their length.

In some embodiments, the plurality of cuts are helical. In particular, it has been found that frame **110** made with a plurality of helical cuts over a portion of the length of the frame **110** creates tines **115** that provide optimal opening characteristics. As shown in **FIG. 4**, the resulting tines **115** from a plurality of helical cuts provides a uniform radial distribution of the  
20 arms, and creates an open passage channel within the shape of the deployed infusion basket **110** in both a straight vessel (**FIG. 4A**) or a curved vessel (**FIG. 4B**). As shown in **FIG. 4C**, the helical-cut frame **110** is optimally designed for deployment within the pulmonary artery, and expands to a deployed state whereby the tines **115** push outward into the greater curvature of the pulmonary artery, thus trapping a clot against the roof of the artery. This  
25 immediately restores blood flow to the affected area and provides the additional benefit of preventing accidental dislodgement of the clot.

Further, the uniform expansion of the internal frame **110**, and thereby of the limbs of basket **100**, along its length ensures uniform distribution of the administered therapeutic agent, and the contact between the limbs and the clot ensures direct administration of the  
30 therapeutic agent to the target area of the clot, improving clinical outcomes and speeding recoveries. The pitch of the plurality of helical cuts may be manipulated to provide the desired deployment characteristics, as shown in **FIG. 5**, which depicts two different frames **110** with helical cuts of differing pitch. In some embodiments, the helical cuts may have a pitch of between one inch and six inches (*i.e.*, the cut may complete one revolution around

the shaft of frame **110** per inch to one revolution per six inches.) In some embodiments, the helical cuts may have a rotation of be between 360° and 1080° over the length of the internal frame **115**. In one embodiment, the plurality of helical cuts have a rotation of approximately 450° over a length of approximately 5 inches, *i.e.*, have a pitch of approximately 4 inches. In  
5 some embodiments, the pitch of the helical cuts may vary over length of the frame **110**, such that, *e.g.*, the distal end may have a greater pitch than at other portions along the length of the frame.

In some embodiments, the frame **110** is constructed of a shape-memory material, and may be made of a nickel-titanium alloy, *e.g.*, nitinol. However, it is to be understood that the  
10 frame **110** may be made of any suitable material as understood by those of ordinary skill in the art, and may include, *e.g.*, stainless steel or cobalt-chrome. The frame **110** may be electropolished and/or heat set after laser cutting is done to form the tines **115**. The heat setting of the frame **110** provides its permanent shape to which it returns after being deformed. In some embodiments, the frame **110** may be heat-set into a closed profile in  
15 which the tines lay flat against the longitudinal axis and essentially form the shape of the shaft. A frame **110** heat-set in this manner may be deployed to an expanded state by, as discussed above, applying a force to reduce the longitudinal length of the frame **110**, and the frame **110** would return to a closed state once the force is removed. In other embodiments, the frame **110** may be heat-set at any stage of deployment, from completely closed to  
20 completely expanded. For example, if heat-set in a completely expanded state, the frame **110** could be placed into a closed state by applying a force to lengthen the longitudinal length of the frame, and the longitudinal length would shorten and the frame **110** would return to an expanded state once the force is removed. An outer sheath may be placed over a heat-set expanded deployable basket **110** to maintain a closed position while basket is maneuvered  
25 through the vasculature into position. The sheath may then be removed to allow expansion at the site of the occlusion, and then the sheath may be replaced afterwards to maintain the closed position for removal.

In some embodiments, the basket **100** may further comprise fiber optic material **150** disposed within one, multiple, or all of the lumens of tubes **120**, as shown in **FIG. 6**. These  
30 fiber optic materials may be connected to a light-emitting device and can be used to direct light energy, *e.g.*, laser energy, **E** from the limbs of basket **100** into a thrombus to provide another mechanism by which the occlusion may be broken down or removed. Thrombi within a blood vessel typically absorb light energy at a specific wavelength that may be minimally absorbed by the walls of the blood vessel. In some embodiments, the light energy emitted

from the fiber optic materials may be at such a wavelength in order to enhance breakdown of a thrombus without damaging the surrounding blood vessel. By delivering light energy through the fiber optic material **150** to a thrombus, in addition to the mechanical compaction and infusion of therapeutic agents as described above, baskets and catheters of the present disclosure may reduce the time required to dissolve a thrombus, which may be over 24 hours when using conventional pharmacological methods alone. In other embodiments, the fiber optic materials may emit light energy that may be used for measurement or diagnostic purposes such as, *e.g.*, determining the size or density of a thrombus.

Another feature of baskets of the present disclosure is the ability to provide both fluid infusion and the delivery of light energy simultaneously, which allows for baskets of the present disclosure to provide an additional cooling benefit to the treatment site. During the transmission and delivery of light as described above, excessive heat can be generated at the treatment site. Excessive heat limits the energy levels available, the duration of treatment, decreases the effectiveness of laser delivery devices, and increases the risk that damage to the tissues could occur. The design of a basket of the present disclosure allows for the infusion of fluid simultaneously with the transmission of light energy. As shown in **FIGS. 6 and 7A-C**, the energy and focal area of the light energy delivered by the fibers **150** is the same as where fluid is infused from the limbs of a basket of the present disclosure. The delivery of fluid simultaneously with the light energy will cool the area where the light energy is focused, allowing higher energy levels to be used, longer treatment durations, and increased overall efficiency. The cooling fluid may be a therapeutic fluid, or may be an inert, biologically acceptable fluid, such as saline. The temperature of the cooling fluid may be varied to provide different degrees of cooling effect. In some embodiments, the temperature of the cooling fluid is between 70° and 90° F.

In some embodiments, the basket **100** may be also be used to deliver radioisotopes to a tissue, and particularly a tumor or cancer. The limbs of the basket **100** may be used to carry an irradiation source and deliver said irradiation source to the tissue to be treated. The irradiation source may be, *e.g.*, seeds, isotopes, liquid, or compositions or materials comprising such seeds, isotopes, or liquids, that emit beta and/or gamma particles. Radioisotopes such as, *e.g.*, radioactive iodine ( $I^{131}$ ), strontium 89, samarium 153, phosphorus 32, yttrium 90, radium 226, cesium 137, cobalt 60, iridium 192, iodine 125, and gold 198 may be used. In some embodiments, heavy shielding may be necessary to prevent radiation damage to healthy tissues as the basket or catheter is delivered through the body to the desired therapeutic site. A catheter sheath may be made of radio-opaque material such as

tantalum or tungsten loaded polymers and used to surround the closed basket. When the basket has been deployed to the target site, the sheath may be retracted, exposing the basket and irradiation source, when may then be deployed to an expanded state to irradiate the site. In this way, beta and/or gamma particles may be delivered evenly to a therapeutic site, *e.g.*, a tumor or cancer.

Also provided is a catheter comprising a basket of the present disclosure. Referring now to **FIG. 7**, a catheter **700** with a proximal end **701** and a distal end **702** comprises a basket **710** as described above comprising a plurality of limbs **711** disposed at a distal end **702** of the catheter **700**. The catheter **700** further comprises an inner shaft **720** comprising a wall with an inner surface and an outer surface and a lumen extending between a distal end and a proximal end is disposed coaxially within the lumen of the frame of basket **700**. This inner shaft **720** may be attached temporarily or permanently at its distal end to the distal end of the basket **710**, for example by gluing or melting the inner shaft **720** to the distal end of the limbs **711** of basket **710**, and/or by a distal end cap **740**. The inner shaft **720** extends from the distal end of the basket **710** to beyond the proximal end of the basket **700** (not shown). The inner shaft **720** is free to move in a longitudinal direction with respect to the proximal end of the basket **700**. The diameter of the lumen of inner shaft **720** may be sized to be compatible with commercial guide wires. Accordingly, a catheter **700** of the present disclosure may be threaded onto a guide wire through the internal lumen of inner shaft **720** to deploy the catheter **700** into position within a blood vessel. In some embodiments, the diameter of the lumen of inner shaft **720** is sized to be adapted for use with blood monitoring systems as known to those of skill in the art. The proximal end of the inner shaft **720** may comprise a connectable fitting, such as a luer connector, that may be connected to blood monitoring systems, including, but not limited to, a pressure transducer system as is typical in a standard hospital catheterization lab. In this way, catheters of the present disclosure allow for concurrent monitoring of a patient's vital signs during deployment and use of the device, which may allow for immediate indication of successful elimination of an occlusion. For example, the presence of an occlusion in a blood vessel may lead to increased blood pressure, and by monitoring the blood pressure during deployment and use of an catheter of the present disclosure, a successful operation may be indicated by an immediate drop in blood pressure as blood flow is restored. In some embodiments, the diameter of the internal lumen of inner shaft **720** is between 0.021 and 0.028 inches. In other embodiments, the fluid connection at the proximal end of the inner shaft **720** may be used to take blood samples.

In other embodiments, inner shaft **720** may be adapted to emit light or radiation energy in a manner similar to as described above, as noted by the arrows **E** extending away from inner shaft **720** in **FIG. 7A**. For example, a fiber optic material may be inserted through the lumen of the inner shaft **720**. The fiber optic material may be connected to a light-

5 emitting device and can be used to direct light energy from the central axis of the basket for therapeutic, measurement, or diagnostic purposes. The light energy may be emitted radially away from the central axis, or may be emitted along the longitudinal axis through the distal end of the inner shaft **720**. The inner shaft **720** may also be used to carry an irradiation source and deliver said irradiation source to the tissue to be treated. In such embodiments,

10 the limbs **711** of basket **710** may serve to center the light and/or radiation energy with the vessel, bodily passage, or tract, as shown in **FIG. 7C**. There the limbs **711** extend radially away from inner shaft **720** and press against the inner surface of a vessel **V**, thereby centering inner shaft **720** within the vessel as light or radiation energy **E** is emitted radially away from inner shaft **720**.

15 An outer shaft **730** comprising a wall with an inner surface and an outer surface and a lumen extending between a distal end and a proximal end disposed coaxially around the portion of the inner shaft that extends proximally beyond the end of the basket **710** to form a fluid compartment between the inner surface of the outer shaft and the outer surface of the inner shaft. The proximal end of the limbs of the basket **710** are connected to the fluid

20 compartment, and a fluid seal **725** may be formed between the inner shaft **720** and the proximal end of the limbs of the basket **710** such that a therapeutic fluid may flow from the fluid compartment into the lumens of the tubes of the limbs of the basket **710** and to the site of the thrombus through the plurality of ports in the tubes. The diameter of the outer shaft **730** is typically between .050 and .120 inches. The proximal end of the outer shaft **730** may

25 terminate in a fitting, such as a luer connector, that may be connected to a drug delivery system for delivering a therapeutic fluid into the catheter.

In a first position, the limbs of the basket **710** lay flat against the inner shaft **720** in a closed manner, as shown in **FIG. 7B**. In this state, the outer diameter of the basket **710** is substantially the same diameter as the outer shaft **730** and distal end cap **740**. The basket **710**

30 may be expanded to a second, open position wherein the limbs expand radially outward from the longitudinal axis by moving the inner shaft **720** in a proximal direction, as shown in **FIG. 7A**. By moving the inner shaft **720** in a proximal direction, the longitudinal length of basket **710** is reduced and the bowing the limbs of the basket **710** bow outward away from the inner shaft **720**. The basket **710** may be returned to the first position by moving the inner shaft **720**

in a distal direction. Thus, a catheter **700** of the present disclosure may be delivered into a blood clot while in a closed first position, deployed into an open second position to both mechanically remove the clot and infuse therapeutic medication to the site, then returned to a closed first position for removal.

5           In some embodiments, catheter **700** comprises a seal **725** disposed between the inner shaft and the proximal end of the plurality of limbs as shown in the cutaway view of **FIG. 8**. The distal end **702** and proximal end **701** of catheter **700** and outer shaft **730** are not shown. The assembly of basket **710** comprising frame **715** and tubes **716**, as discussed above, is shown. As discussed above, ends of tubes **716** may be joined together permanently or  
10 temporarily, with appropriate measures taken to ensure that the various lumens remain open during the joining process (*e.g.*, by insertion of mandrels into the various lumens). The inner shaft **720** disposed coaxially within the internal lumen of basket **710**. A seal **725** comprising a wall with an outer surface and an inner surface and a lumen from a distal end to a proximal end is disposed between the inner shaft **720** and the internal lumen of basket **710**. The outer  
15 surface of the wall of seal **725** may be joined, either temporarily or permanently, to the lumen of basket **710** via, *e.g.*, melting or gluing, thereby sealing the internal lumen of basket **710** against the outer surface of the wall of seal **725**. The outer shaft **730** (not shown) would be disposed coaxially around the inner shaft **720** as described above, and the distal end of outer shaft **730** would be joined to the proximal end of the limbs of basket **710** to form a fluid seal  
20 between the fluid compartment formed between the inner surface of the wall of the outer shaft **730** and the outer wall of the inner shaft **720** and the limbs of basket **710**. The inner diameter of the lumen of seal member **725** is substantially the same diameter as the outer diameter of the inner shaft **720** such that inner shaft **720** is slideable in a longitudinal direction within the lumen of seal member **725** while preventing fluid from leaking out of the  
25 distal end of the fluid compartment through the internal lumen of the basket **710**. In some embodiments, the inner diameter of the lumen of seal member **725** may be slightly larger than the outer diameter of the inner shaft **720** such that a small amount of fluid may be allowed to enter the space. This small amount of fluid effectively seals the space to prevent additional fluid from leaking, while allowing inner shaft **720** to move proximally and distally along the longitudinal axis. The ability of seal member **725** to prevent fluid leakage may also be  
30 controlled by altering the length of seal member **725**, such that the interface between the inner surface of its wall with the outer surface of the wall of the inner shaft **720** extends for a shorter distance, to decrease to sealing ability, or longer distance, to increase the sealing ability. Typical lengths of the sealing member **725** may be 2 to 8 inches, and can extend a

portion of the length of the basket **710**. As shown in **FIG. 7A**, the seal member **725** extends for a length of approximately half of basket **710**.

In addition to a blood vessel, the baskets and catheters of the present disclosure may be utilized in any other bodily vessel or tract where a deployable basket may be disposed.

5 This may include other areas of the body including, but not limited to, a portion of the digestive, urinary, and biliary tracts, or other vessels or passages of body.

The various tubings, shafts, and seals of the baskets and catheters of the present disclosure may be any suitable material as known to those of ordinary skill in the art, including, but not limited to, polyimide, polytetrafluoroethylene (PTFE), expanded  
10 polytetrafluoroethylene (ePTFE), polyvinylidene fluoride (PVDF), high-density polyethylene (HDPE), Nylon 6, Pebax, or nylon. The tubing may also be braided with, *e.g.*, stainless steel, shape memory metals, or polymer fibers.

**FIG. 9** shows an infusion catheter device according to an embodiment of the present disclosure. The distal end of infusion catheter **900** comprises a basket **910**, inner shaft **920**,  
15 outer shaft **930**, sealing member **925**, and distal end cap **940** as generally described above. The proximal end of the infusion catheter **900** comprises a handle **950**. The handle further comprises a slide **955** that is connected to the proximal end of inner shaft **920** of the infusion catheter **900**. The slide **955** may be used to deploy the basket to an expanded state by moving the slide in a proximal direction, thereby moving the inner shaft **920** in a proximal direction  
20 and radially expanding the basket **910** as generally described above. The proximal end of inner shaft **920** may extend beyond the end of handle **950** and terminate in a luer connector **921**. This luer connector may be connected to a transducer for monitoring a patient's vital signs during use, or may be connected to other components to take blood samples. Handle **950** may also comprise an infusion shaft **960** that is fluidly connected to the proximal end of  
25 outer shaft **930**. Infusion shaft **960** is terminated with a luer connector **961** that may be connected to a drug delivery system, such as an intravenous pump.

Also provided herein are methods of treatment and methods of catheter-directed thrombolysis. The method may comprise providing an infusion catheter of the present disclosure and as described above, advancing the deployable infusion basket at least partially  
30 through a thrombus within a vessel in a first position; deploying the deployable infusion basket to a second position; and simultaneously infusing a therapeutic agent through the infusion ports of the limbs of the deployable infusion basket. In some embodiments, the limbs of the deployable infusion basket are in a closed state in the first position and radially expand away from the longitudinal axis in the second position. In this manner, methods of

the present disclosure provide for mechanical opening of a blood vessel while simultaneously delivering a therapeutic agent to pharmaceutically dissolve the clot. In some embodiments, light energy may be applied to the clot. Methods of the present disclosure may be employed on any vessel afflicted by a thrombus, including, but not limited to, the inferior vena cava, the superior vena cava, the iliac veins, the aorta, the pulmonary artery, or the pulmonary vein. As discussed above, the deployable infusion basket of the present disclosure is optimally designed for functioning within these large, curved vasculatures.

It will be apparent to one of ordinary skill in the art that various combinations and/or modifications and variations can be made in the infusion catheter systems and devices of the present disclosure depending upon the specific needs for operation and as dictated by the therapeutic needs of the patient. Moreover, features illustrated or described as being part of one embodiment may be used on another embodiment to yield a still further embodiment.

**CLAIMS****WHAT IS CLAIMED IS:**

1. A basket for an infusion catheter comprising:  
a shaft comprising a wall with an inner surface and an outer surface and a lumen  
5 extending between a distal end and a proximal end and defining a longitudinal axis, wherein a plurality of helical cuts along a portion of the shaft between the inner and outer surface of the wall form a plurality of tines; wherein the proximal end of the shaft is uncut;  
a plurality of tubes, each tube comprising a wall with an inner surface and an outer  
10 surface and a lumen extending between a distal end and a proximal end; wherein the plurality of tubes are melted together and to the outside of the shaft at the uncut proximal end of the shaft;  
wherein each of the plurality of tines of the shaft are disposed in the lumen of each of the plurality of tubes to form a plurality of limbs; wherein the plurality of tines independently support the limbs without interconnection of tines between the proximal and distal end of the  
15 tines; and wherein the distal end of each of the plurality of limbs are attached together.
2. The basket of claim 1, wherein the limbs of the basket deploy from a first position to a second position when the longitudinal length of the basket is reduced.
3. The basket of claim 2, wherein the limbs of the basket are in a closed state in the first  
20 position.
4. The basket of claim 1, wherein the limbs of the basket expand radially away from the longitudinal axis when the longitudinal length of the basket is reduced.
5. The basket of claim 1, wherein the shaft comprises a shape memory material.
6. The basket of claim 5, wherein the shape memory material is a nickel-titanium nitinol alloy.
- 25 7. The basket of claim 1, wherein the plurality of cuts are formed by laser cutting.
8. The basket of claim 1, wherein the plurality of cuts are helical and have a rotation of at least 360 degrees over the length of the deployable infusion basket.
9. The basket of claim 8, wherein the plurality of helical cuts have a rotation of at least 450 degrees over the length of the deployable infusion basket.
- 30 10. The basket of claim 1, wherein each of the plurality of tubes is porous.
11. The basket of claim 10, wherein each of the plurality of tubes comprises a plurality of infusion ports extending between the inner surface and outer surface of the wall of the tube.
12. The basket of claim 11, wherein the infusion ports are holes having diameters between 0.001 and 0.006 inches.

13. The basket of claim 1, wherein the deployable infusion basket is between three and eight inches in length.
14. The basket of claim 1, wherein the deployable infusion basket is about six inches in length.
- 5 15. The basket of claim 1, further comprising a fiber optic material disposed within the lumen of at least one of the plurality of tubes.
16. A catheter comprising:  
a basket comprising:  
a shaft comprising a wall with an inner surface and an outer surface and a lumen  
10 extending between a distal end and a proximal end and defining a longitudinal axis, wherein a plurality of helical cuts along at least a portion of the shaft between the inner and outer surface of the wall form a plurality of tines wherein the proximal end of the shaft is uncut;  
a plurality of tubes, each tube comprising a wall with an inner surface and an outer surface and a lumen extending between a distal end and a proximal end;  
15 wherein the each of the plurality of tines of the shaft are disposed in the lumen of each of the plurality of tubes to form a plurality of limbs;  
wherein the plurality of tines independently support the limbs without interconnection of tines between the proximal and distal end of the tines; and  
wherein the distal end of each of the plurality of limbs are attached and the proximal  
20 end of each of the plurality of limbs are melted together and to the outside of the shaft;  
an inner shaft comprising a wall with an inner surface and an outer surface and a lumen extending between a distal end and a proximal end, wherein the inner shaft is disposed coaxially within the lumen of the shaft and is attached to the distal end of the basket;  
an outer shaft comprising a wall with an inner surface and an outer surface and a  
25 lumen extending between a distal end and a proximal end, wherein the outer shaft is disposed coaxially around the inner shaft to form a fluid compartment between the inner surface of the outer shaft and the outer surface of the inner shaft; and  
wherein the proximal end of the limbs of the basket are connected to the fluid compartment.
- 30 17. The catheter of claim 16, wherein the connection between the proximal end of the limbs of the basket and the fluid compartment comprises a seal disposed between the inner shaft and the proximal end of the plurality of limbs.
18. The catheter of claim 16, wherein the limbs of the basket deploy from a first position to a second position when the inner shaft is moved in a proximal direction.

19. The catheter of claim 16, wherein the limbs of the basket expand radially away from the longitudinal axis when the inner shaft is moved in a proximal direction.
20. The catheter of claim 16, wherein each of the plurality of tubes comprises a plurality  
5 of infusion ports extending between the inner surface and outer surface of the wall of the tube.
21. The catheter of claim 16, further comprising a fiber optic material disposed within the lumen of the inner shaft or at least one of the plurality of tubes.
22. The catheter of claim 16, wherein the basket further comprises an irradiation source.
- 10 23. A method of catheter-directed thrombolysis, the method comprising: providing a catheter comprising
- a basket comprising:
    - a shaft comprising a wall with an inner surface and an outer surface and a lumen extending between a distal end and a proximal end and defining a longitudinal axis, wherein a  
15 plurality of helical cuts along at least a portion of the shaft between the inner and outer surface of the wall form a plurality of tines, wherein the proximal end of the shaft is uncut;
    - a plurality of tubes, each tube comprising a wall with an inner surface and an outer surface and a lumen extending between a distal end and a proximal end, wherein the plurality of tubes are melted together and to the outside of the shaft at the uncut proximal end of the  
20 shaft, wherein the each of the plurality of tines of the shaft are disposed in the lumen of each of the plurality of tubes to form a plurality of limbs, wherein the plurality of tines independently support the limbs without interconnection of tines between the proximal and distal end of the tines; and
    - wherein the distal end of each of the plurality are attached together;
  - 25 an inner shaft comprising a wall with an inner surface and an outer surface and a lumen extending between a distal end and a proximal end, wherein the inner shaft is disposed coaxially within the lumen of the shaft and is attached to the distal end of the basket;
  - an outer shaft comprising a wall with an inner surface and an outer surface and a lumen extending between a distal end and a proximal end, wherein the outer shaft is disposed coaxially  
30 around the inner shaft to form a fluid compartment between the inner surface of the outer shaft and the outer surface of the inner shaft; and
  - wherein the proximal end of the limbs of the basket are connected to the fluid compartment;

advancing the infusion basket at least partially through a thrombus within a vessel in a first position;

deploying the basket to a second position; and

5 simultaneously infusing a therapeutic fluid through the infusion ports of the limbs of the basket.

24. The method of claim 23, wherein the limbs of the basket are in a closed state in the first position and radially expand away from the longitudinal axis in the second position.

25. The method of claim 24, wherein a fluid opening through the thrombus is created when deploying the basket to the second position.

10 26. The method of claim 23, wherein the therapeutic fluid comprises a thrombolytic agent.

27. The method of claim 23, further comprising delivering light energy to the thrombus.

28. The method of claim 27, wherein the light energy is delivered to the thrombus through a fiber optic material disposed within the lumen of the inner shaft or at least one of  
15 the plurality of tubes.

29. The method of claim 27, wherein the light energy is delivered to the thrombus simultaneously with the infusion of the therapeutic fluid.

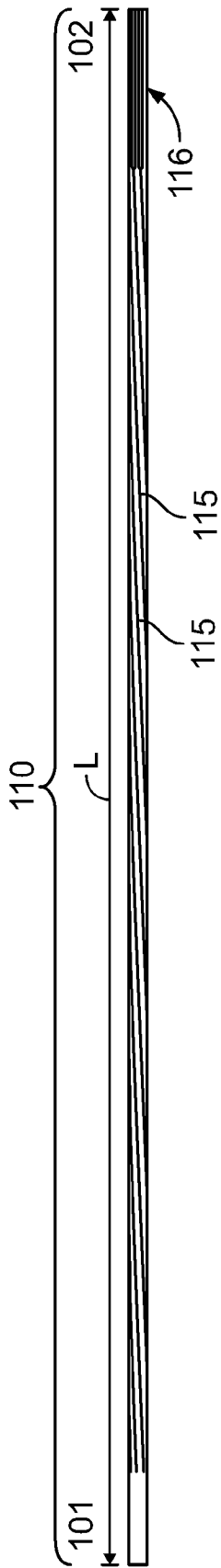

FIG. 1A

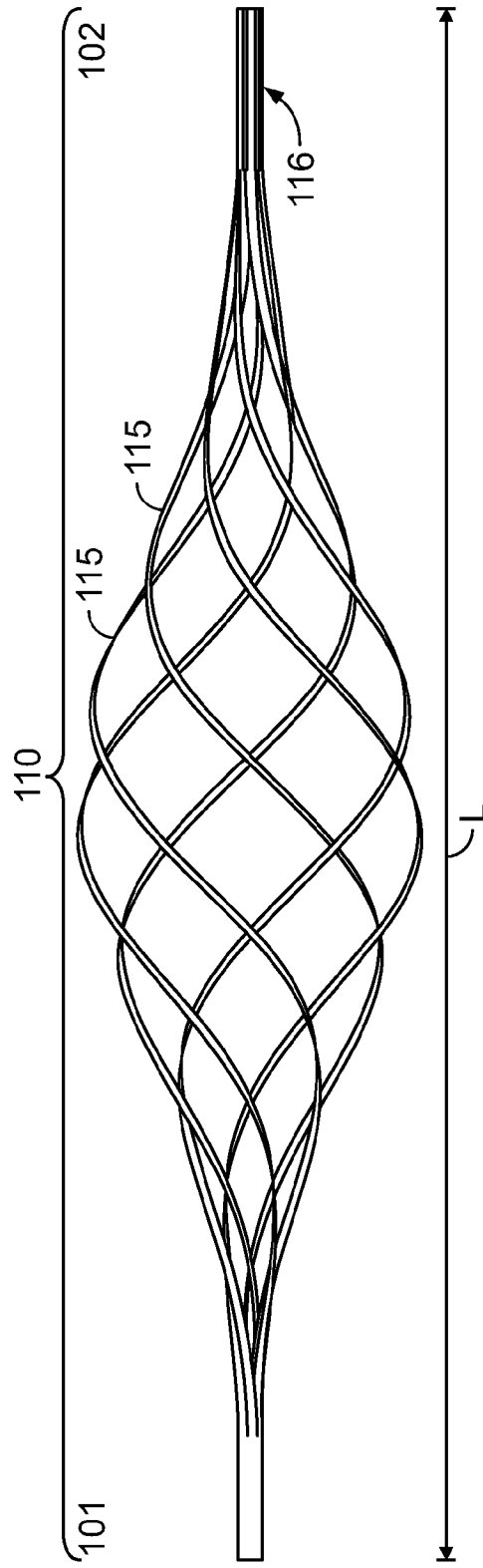

FIG. 1B

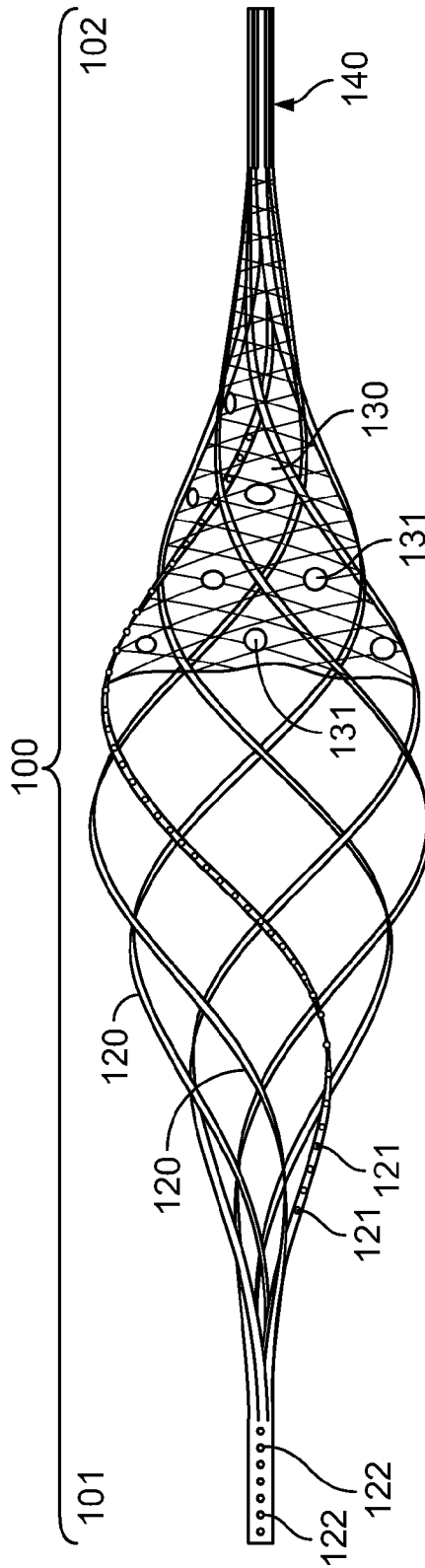

FIG. 1C



FIG. 2

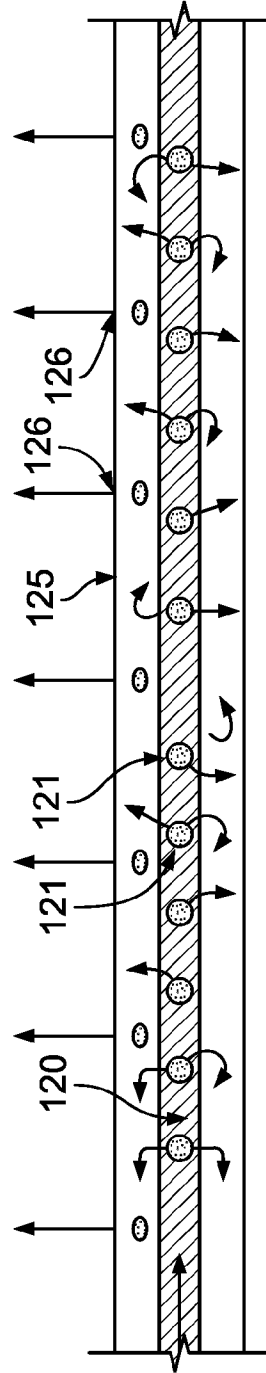

FIG. 3

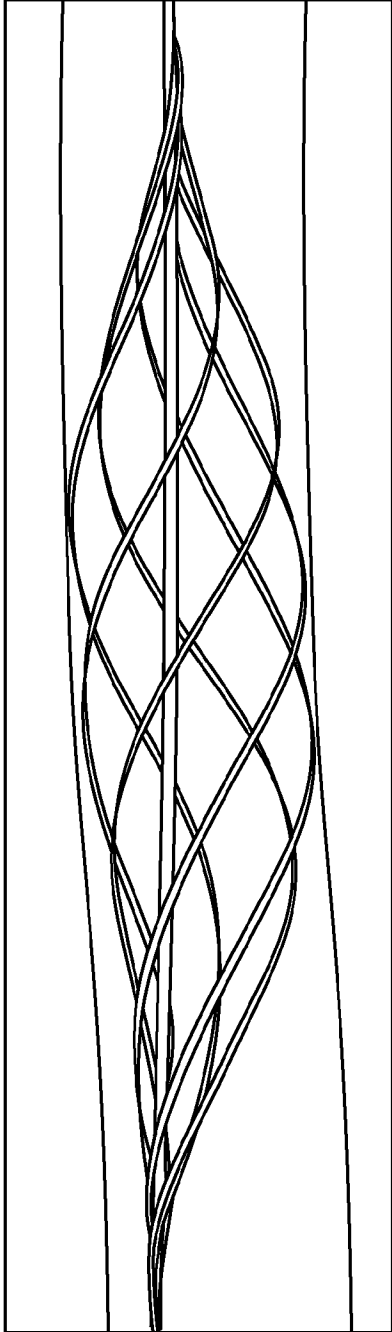

FIG. 4A

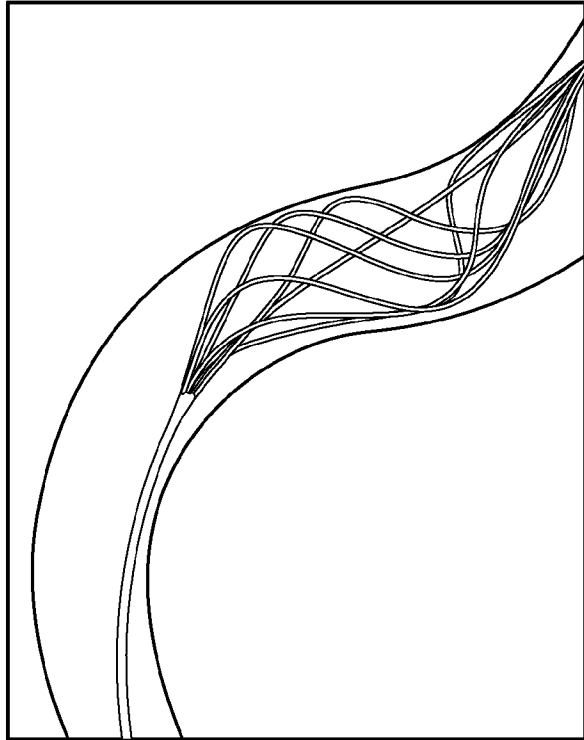

FIG. 4B

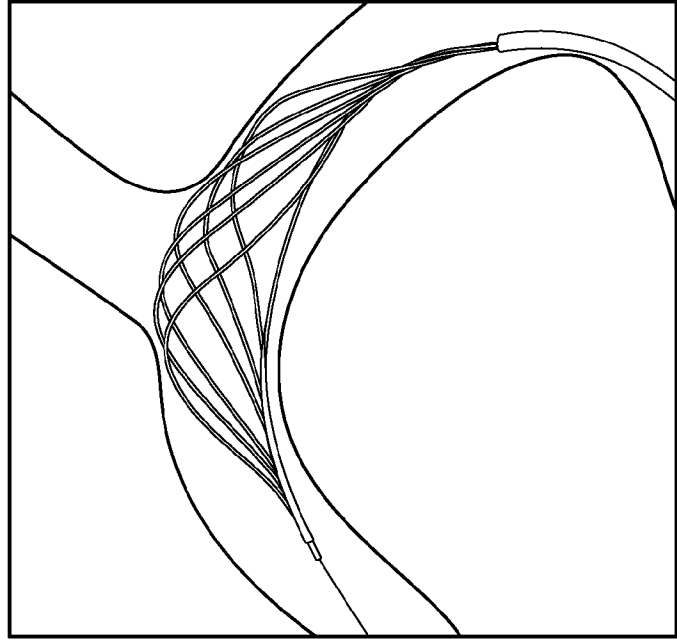

FIG. 4C

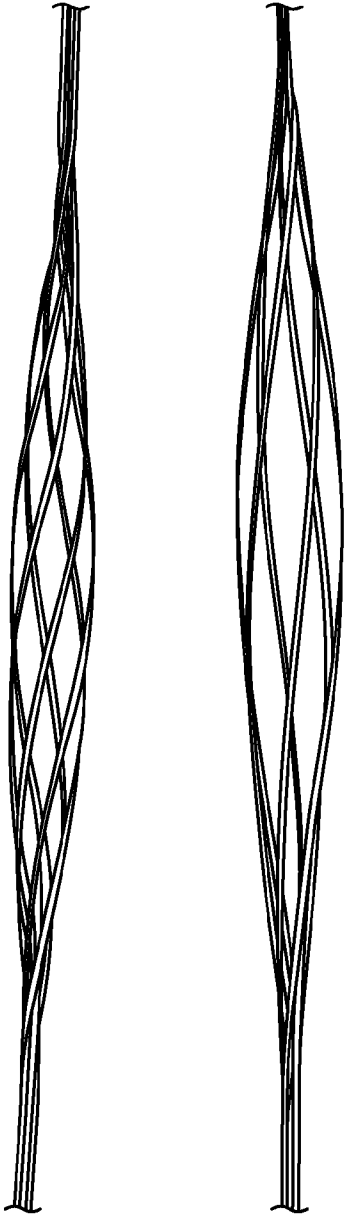

FIG. 5

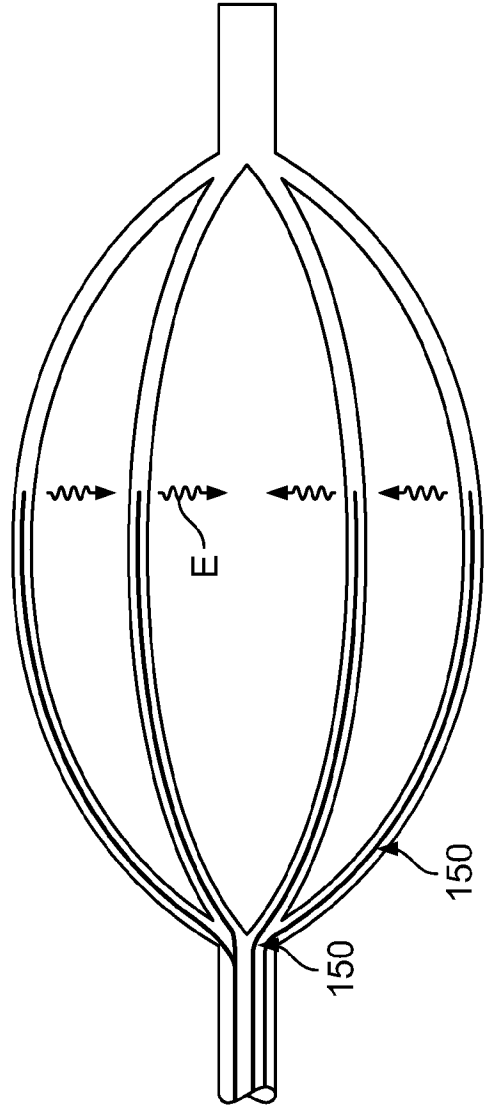

FIG. 6

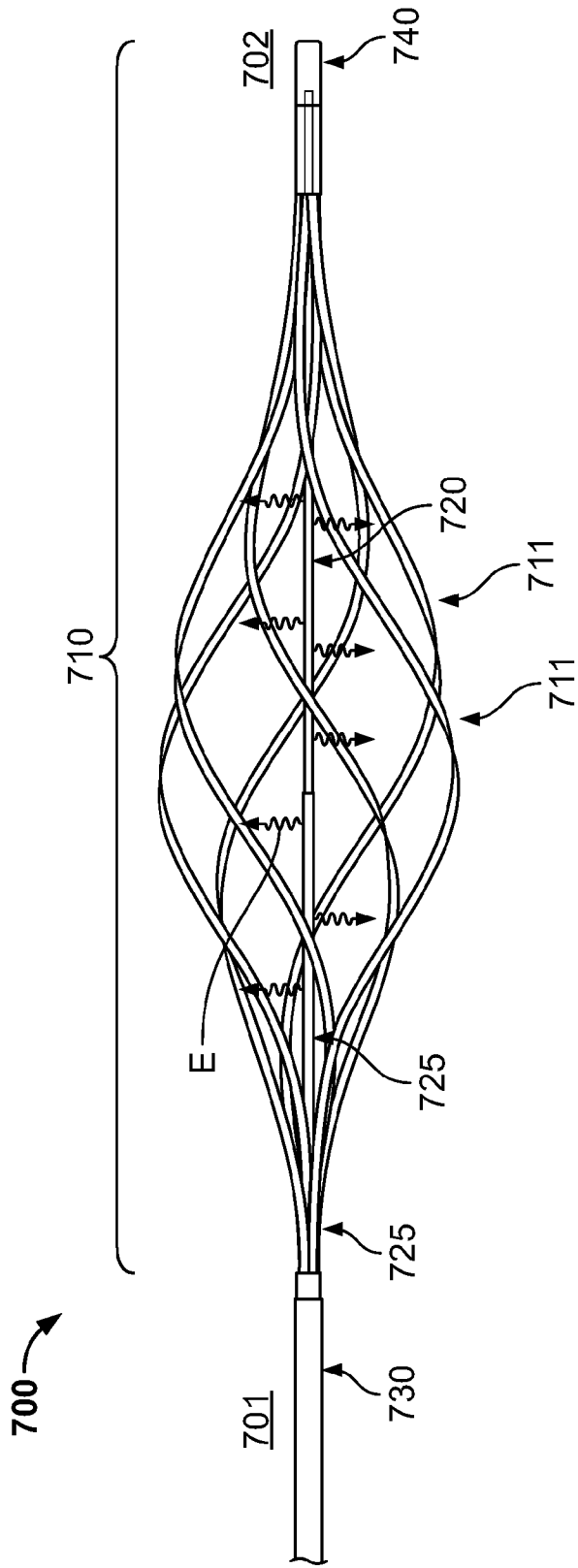

FIG. 7A

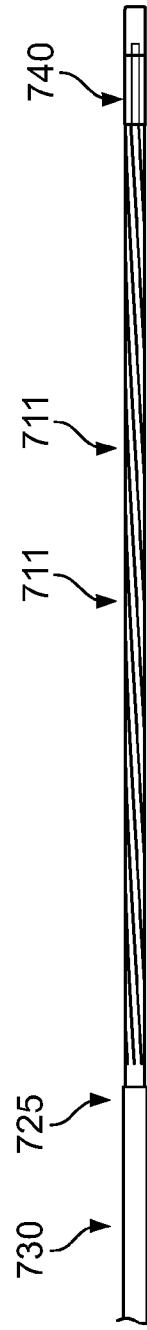
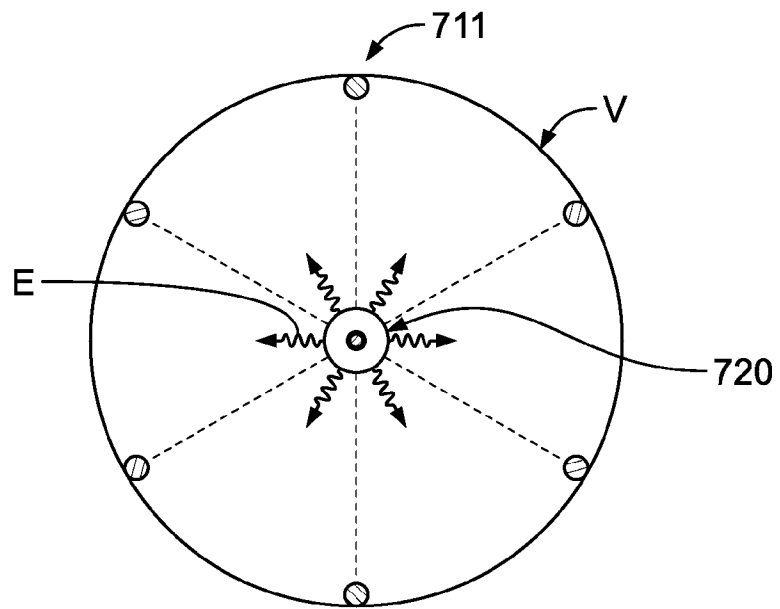

FIG. 7B



**FIG. 7C**

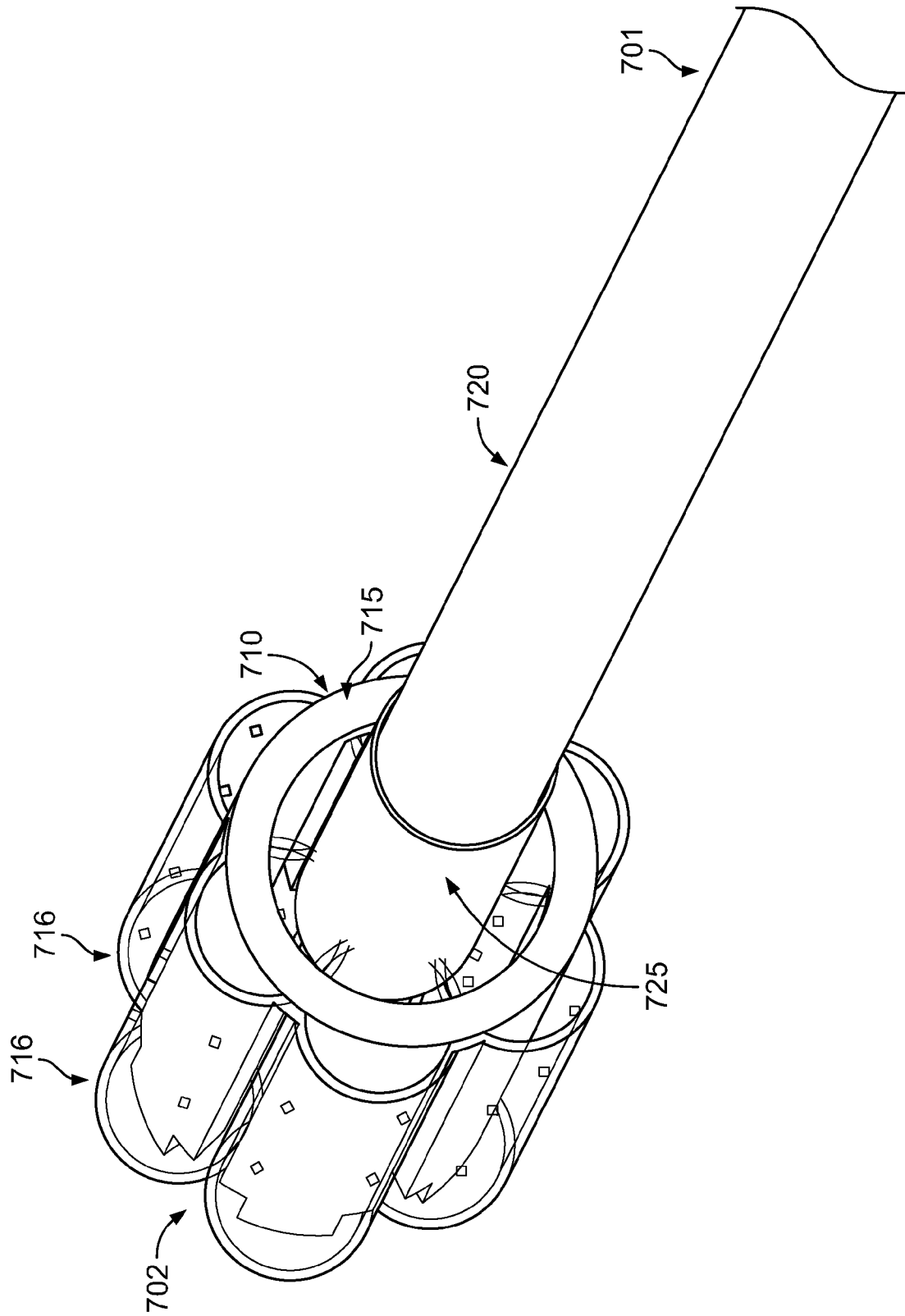

FIG. 8

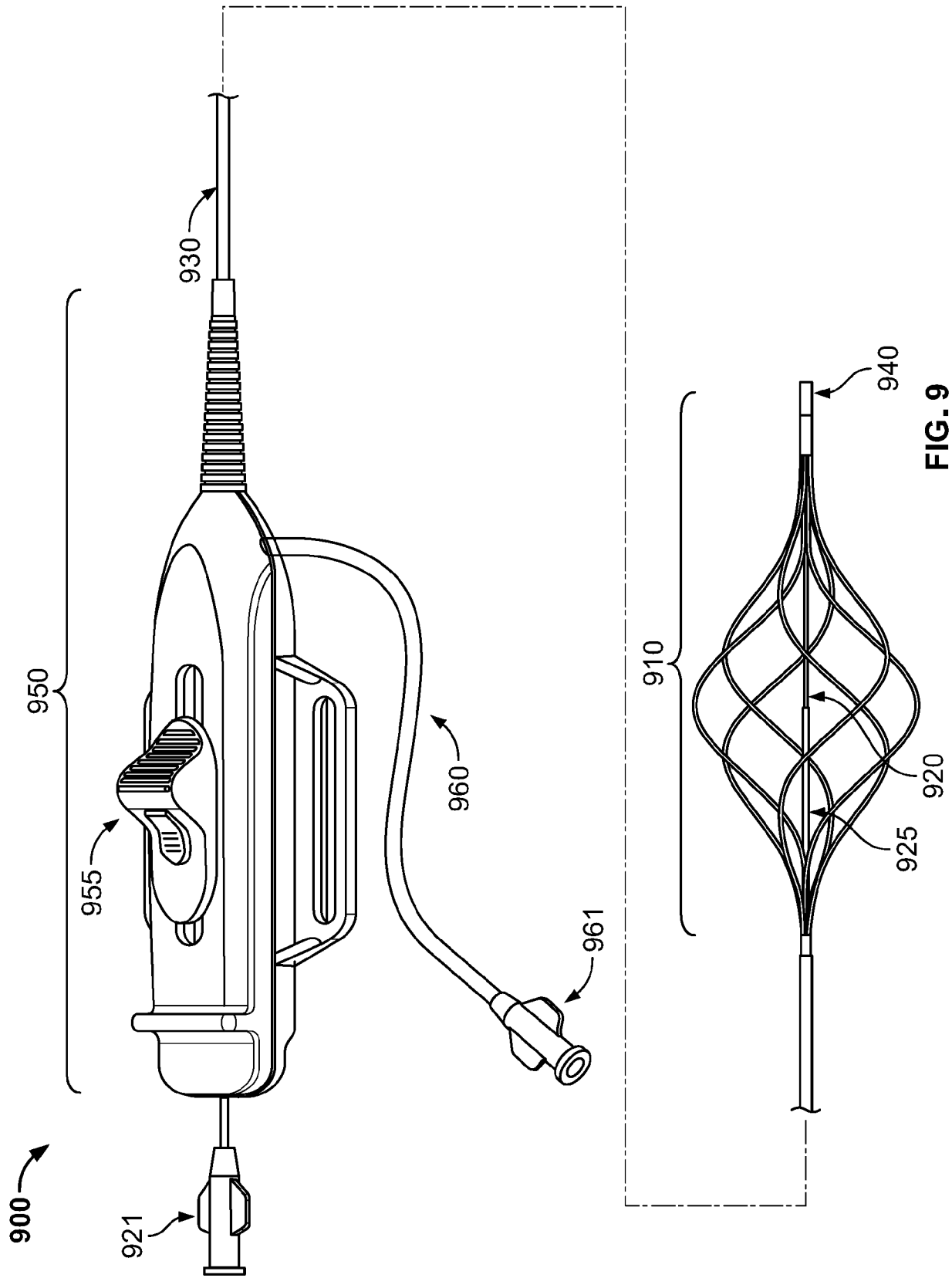

FIG. 9

## INTERNATIONAL SEARCH REPORT

International application No.

PCT/US 18/60115

A. CLASSIFICATION OF SUBJECT MATTER  
 IPC(8) - A61B 17/22, A61F 2/06, A61F 2/88, A61F 2/90, A61F 13/45, A61M 5/14, A61M 25/10 (2018.01)  
 CPC - A61B 5/150389, A61B 5/6858, A61B 17/22, A61B 2017/06076, A61B 17/22032, A61B 2017/22051, A61B 2017/22072, A61B 2017/22074, A61B 2017/22077, A61B 2017/22095, A61B 2018/00267, A61F 2/88, A61F 2/90, A61F 13/45, A61F 2002/061, A61F 2013/4506, A61F 2230/0091, A61M 5/14228, A61M 25/0012, A61M 25/0015, A61M 25/10, A61M 25/1036, A61M 25/104, A61M 25/1006, A61M 2025/1045, A61M 2025/1086

According to International Patent Classification (IPC) or to both national classification and IPC

## B. FIELDS SEARCHED

Minimum documentation searched (classification system followed by classification symbols)

See Search History Document

Documentation searched other than minimum documentation to the extent that such documents are included in the fields searched

See Search History Document

Electronic data base consulted during the international search (name of data base and, where practicable, search terms used)

See Search History Document

## C. DOCUMENTS CONSIDERED TO BE RELEVANT

Category*	Citation of document, with indication, where appropriate, of the relevant passages	Relevant to claim No.
A	US 2016/0296245 A1 (YU) 13 October 2016 (13.10.2016), para [0006], [0011], [0014]	1-29
A	US 2012/0059309 A1 (DI PALMA) 08 March 2012 (08.03.2012), para [0004], [0005], [0028], [0030], [0037]-[0039]	1-29
A	US 2004/0133232 A1 (ROSENBLUTH et al.) 08 July 2004 (08.07.2004), para [0023], [0030], [0031], [0116], [0119], [0118], [0122], [0139], [0166], [0167], [0179], [0185]	1-29
A	US 2003/0055401 A1 (LARSON et al.) 20 March 2003 (20.03.2003), Fig. 5; para [0009], [0041], [0044]	1-29
X, P	US 10,105,154 B1 (GREEN) 23 October 2018 (23.10.2018), col 1, ln 35 to col 14, ln 46	1-29

Further documents are listed in the continuation of Box C.  See patent family annex.

\* Special categories of cited documents:

"A" document defining the general state of the art which is not considered to be of particular relevance

"E" earlier application or patent but published on or after the international filing date

"L" document which may throw doubts on priority claim(s) or which is cited to establish the publication date of another citation or other special reason (as specified)

"O" document referring to an oral disclosure, use, exhibition or other means

"P" document published prior to the international filing date but later than the priority date claimed

"T" later document published after the international filing date or priority date and not in conflict with the application but cited to understand the principle or theory underlying the invention

"X" document of particular relevance; the claimed invention cannot be considered novel or cannot be considered to involve an inventive step when the document is taken alone

"Y" document of particular relevance; the claimed invention cannot be considered to involve an inventive step when the document is combined with one or more other such documents, such combination being obvious to a person skilled in the art

"&" document member of the same patent family

Date of the actual completion of the international search

24 December 2018

Date of mailing of the international search report

24 JAN 2019

Name and mailing address of the ISA/US

Mail Stop PCT, Attn: ISA/US, Commissioner for Patents  
 P.O. Box 1450, Alexandria, Virginia 22313-1450  
 Facsimile No. 571-273-8300

Authorized officer:

Lee W. Young

PCT Helpdesk: 571-272-4300  
 PCT OSP: 571-272-7774