

**(12) STANDARD PATENT**  
**(19) AUSTRALIAN PATENT OFFICE**

(11) Application No. **AU 2018331954 B2**

(54) Title  
**Negative pressure wound treatment apparatuses and methods with integrated electronics**

(51) International Patent Classification(s)  
**A61M 1/00** (2006.01)

(21) Application No: **2018331954** (22) Date of Filing: **2018.09.13**

(87) WIPO No: **WO19/053101**

(30) Priority Data

(31) Number	(32) Date	(33) Country
<b>62/558264</b>	<b>2017.09.13</b>	<b>US</b>

(43) Publication Date: **2019.03.21**

(44) Accepted Journal Date: **2024.07.04**

(71) Applicant(s)  
**Smith & Nephew plc**

(72) Inventor(s)  
**HARRISON, Frederick Jethro; HESKETH, Mark Richard; KELBIE, William; ROBINSON, Joseph William; STEWARD, Daniel Lee; WEST, Grant**

(74) Agent / Attorney  
**Griffith Hack, Level 15 376-390 Collins St, MELBOURNE, VIC, 3000, AU**

(56) Related Art  
**US 2015/0174304 A1**  
**WO 2016/103035 A2**  
**US 2011/0071483 A1**  
**US 2005/0088184 A1**



- (51) International Patent Classification:  
*A61M 1/00* (2006.01)
- (21) International Application Number:  
PCT/EP2018/074694
- (22) International Filing Date:  
13 September 2018 (13.09.2018)
- (25) Filing Language: English
- (26) Publication Language: English
- (30) Priority Data:  
62/558264 13 September 2017 (13.09.2017) US
- (71) Applicant: **SMITH & NEPHEW PLC** [GB/GB]; 15  
Adam Street, London WC2N 6LA (GB).
- (72) Inventors: **HARRISON, Frederick, Jethro**; PA Consulting Services Limited Back Lane, Melbourn, Cambridge Hertfordshire SG8 6DP (GB). **HESKETH, Mark, Richard**; PA Consulting Services Limited Back Lane, Melbourn, Cambridge Hertfordshire SG8 6DP (GB). **KELBIE,**

**William**; Smith & Nephew 101 Hessle Road, Hull HU3 2BN (GB). **ROBINSON, Joseph, William**; PA Consulting Services Limited Back Lane, Melbourn, Cambridge Hertfordshire SG8 6DP (GB). **STEWART, Daniel, Lee**; Smith & Nephew 101 Hessle Road, Hull HU3 2BN (GB). **WEST, Grant**; PA Consulting Services Limited Back Lane, Melbourn, Cambridge Hertfordshire SG8 6DP (GB).

(74) Agent: **HINES, Adam**; Smith & Nephew, 101 Hessle Road, Hull East Yorkshire HU3 2BN (GB).

(81) Designated States (*unless otherwise indicated, for every kind of national protection available*): AE, AG, AL, AM, AO, AT, AU, AZ, BA, BB, BG, BH, BN, BR, BW, BY, BZ, CA, CH, CL, CN, CO, CR, CU, CZ, DE, DJ, DK, DM, DO, DZ, EC, EE, EG, ES, FI, GB, GD, GE, GH, GM, GT, HN, HR, HU, ID, IL, IN, IR, IS, JO, JP, KE, KG, KH, KN, KP, KR, KW, KZ, LA, LC, LK, LR, LS, LU, LY, MA, MD, ME, MG, MK, MN, MW, MX, MY, MZ, NA, NG, NI, NO, NZ, OM, PA, PE, PG, PH, PL, PT, QA, RO, RS, RU, RW, SA,

(54) Title: NEGATIVE PRESSURE WOUND TREATMENT APPARATUSES AND METHODS WITH INTEGRATED ELECTRONICS

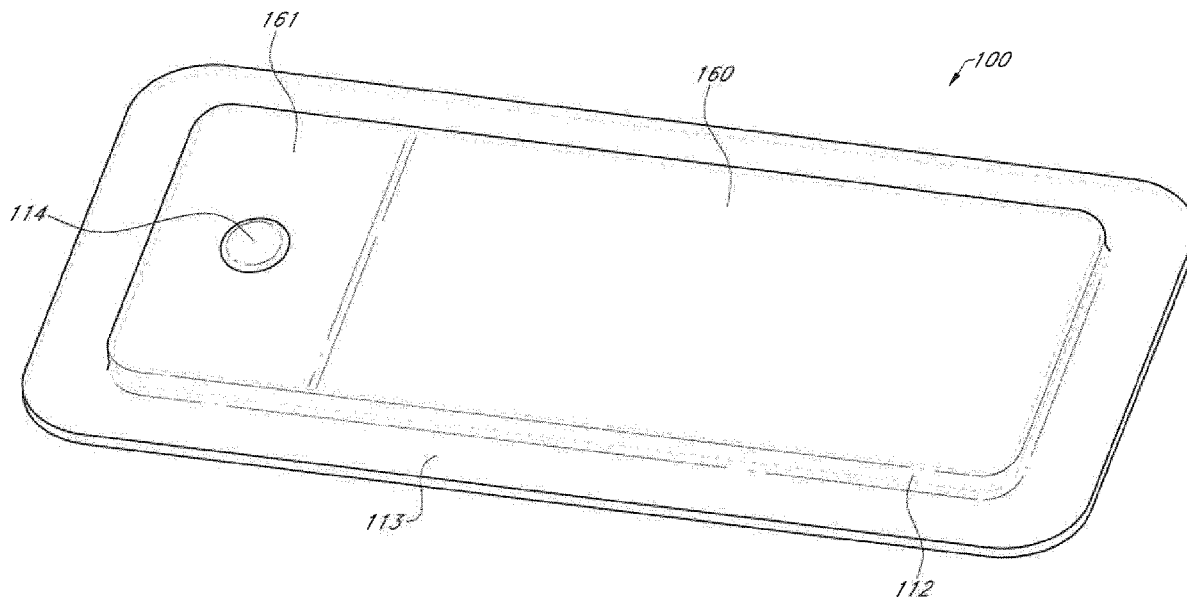

FIG. 1A

(57) Abstract: Disclosed embodiments relate to apparatuses and methods for wound treatment. A wound dressing apparatus can comprise a wound contact layer, at least one absorbent layer, an electronics unit comprising a negative pressure source unit, and a cover layer. The electronics unit can comprise a plurality of sensors positioned on a printed circuit board and an inlet protection mechanism of the negative pressure source unit comprises a first recess in fluid communication with a first sensor and the outlet or exhaust mechanism of the negative pressure source unit comprises a second recess in fluid communication with a second sensor.



SC, SD, SE, SG, SK, SL, SM, ST, SV, SY, TH, TJ, TM, TN,  
TR, TT, TZ, UA, UG, US, UZ, VC, VN, ZA, ZM, ZW.

- (84) Designated States** (*unless otherwise indicated, for every kind of regional protection available*): ARIPO (BW, GH, GM, KE, LR, LS, MW, MZ, NA, RW, SD, SL, ST, SZ, TZ, UG, ZM, ZW), Eurasian (AM, AZ, BY, KG, KZ, RU, TJ, TM), European (AL, AT, BE, BG, CH, CY, CZ, DE, DK, EE, ES, FI, FR, GB, GR, HR, HU, IE, IS, IT, LT, LU, LV, MC, MK, MT, NL, NO, PL, PT, RO, RS, SE, SI, SK, SM, TR), OAPI (BF, BJ, CF, CG, CI, CM, GA, GN, GQ, GW, KM, ML, MR, NE, SN, TD, TG).

**Published:**

- *with international search report (Art. 21(3))*
- *before the expiration of the time limit for amending the claims and to be republished in the event of receipt of amendments (Rule 48.2(h))*

## NEGATIVE PRESSURE WOUND TREATMENT APPARATUSES AND METHODS WITH INTEGRATED ELECTRONICS

### RELATED APPLICATIONS

[0001] This application claims priority to U.S. Provisional Patent Application No. 62/558,264, filed on September 13, 2017, which is hereby incorporated by reference in its entirety and made part of this disclosure.

### BACKGROUND

#### Technical Field

[0002] Embodiments described herein relate to apparatuses, systems, and methods the treatment of wounds, for example using dressings in combination with negative pressure wound therapy.

#### Description of the Related Art

[0003] The treatment of open or chronic wounds that are too large to spontaneously close or otherwise fail to heal by means of applying negative pressure to the site of the wound is well known in the art. Negative pressure wound therapy (NPWT) systems currently known in the art commonly involve placing a cover that is impermeable or semi-permeable to fluids over the wound, using various means to seal the cover to the tissue of the patient surrounding the wound, and connecting a source of negative pressure (such as a vacuum pump) to the cover in a manner so that negative pressure is created and maintained under the cover. It is believed that such negative pressures promote wound healing by facilitating the formation of granulation tissue at the wound site and assisting the body's normal inflammatory process while simultaneously removing excess fluid, which may contain adverse cytokines and/or bacteria. However, further improvements in NPWT are needed to fully realize the benefits of treatment.

[0004] Many different types of wound dressings are known for aiding in NPWT systems. These different types of wound dressings include many different types of materials and layers, for example, gauze, pads, foam pads or multi-layer wound dressings. One example of a multi-layer wound dressing is the PICO dressing, available from Smith & Nephew, which includes a superabsorbent layer beneath a backing layer to provide a canister-less system for treating a wound with NPWT. The wound dressing may be sealed to

a suction port providing connection to a length of tubing, which may be used to pump fluid out of the dressing and/or to transmit negative pressure from a pump to the wound dressing.

[0005] Prior art dressings for use in negative pressure such as those described above have included a negative pressure source located in a remote location from the wound dressing. Negative pressure sources located remote from the wound dressing have to be held by or attached to the user or other pump support mechanism. Additionally, a tubing or connector is required to connect the remote negative pressure source to the wound dressing. The remote pump and tubing can be cumbersome and difficult to hide in or attach to patient clothing. Depending on the location of the wound dressing, it can be difficult to comfortably and conveniently position the remote pump and tubing. When used, wound exudate may soak into the dressing, and the moisture from the wound has made it difficult to incorporate electronic components into the dressing.

#### SUMMARY

[0006] Embodiments of the present disclosure relate to apparatuses and methods for wound treatment. Some of the wound treatment apparatuses described herein comprise a negative pressure source or a pump system for providing negative pressure to a wound. Wound treatment apparatuses may also comprise wound dressings that may be used in combination with the negative pressure sources and pump assemblies described herein. In some embodiments, a negative pressure source is incorporated into a wound dressing apparatus so that the wound dressing and the negative pressure source are part of an integral or integrated wound dressing structure that applies the wound dressing and the negative pressure source simultaneously to a patient's wound. The negative pressure source and/or electronic components may be positioned between a wound contact layer and a cover layer of the wound dressing. An electronics assembly can be incorporated into the absorbent material of the dressing to prevent pooling of wound exudate and maintain conformability of the dressing. These and other embodiments as described herein are directed to overcoming particular challenges involved with incorporating a negative pressure source and/or electronic components into a wound dressing.

[0007] According to one aspect, the invention provides a wound dressing apparatus comprising: a wound contact layer comprising a proximal wound-facing face and a distal face, wherein the proximal wound-facing face is configured to be positioned in contact with a wound; at least one absorbent layer over the wound contact layer; and an electronics

unit comprising: a negative pressure source unit comprising a negative pressure source, a pump inlet protection mechanism, and a pump outlet or exhaust mechanism; a plurality of sensors positioned on a printed circuit board, wherein the pump inlet protection mechanism comprises a first cavity configured to surround a first sensor on the printed circuit board, and a first recess configured to receive an inlet port of the negative pressure source, wherein the pump outlet or exhaust mechanism comprises a second cavity configured to surround a second sensor on the printed circuit board, wherein the at least one absorbent layer is configured to be in fluid communication with the electronics unit; and a cover layer configured to cover and form a seal over the wound contact layer and the at least one absorbent layer.

**[0008]** The wound dressing apparatus of the preceding paragraph or in other embodiments can include one or more of the following features. The first recess can be positioned over the first sensor, wherein the perimeter of the first recess comprises a first gasket configured to seal the perimeter of the first recess in the inlet protection mechanism to the printed circuit board surrounding the first sensor. The second recess can be positioned over the second sensor, wherein the perimeter of the second recess comprises a second gasket configured to seal the perimeter of the second recess of the outlet or exhaust mechanism to the printed circuit board surrounding the second sensor. The outlet or exhaust mechanism can comprise at least one vent aperture and the printed circuit board can comprise at least one vent hole in the printed circuit board, wherein the at least one vent aperture of the outlet or exhaust mechanism is configured to be in fluid communication with the at least one vent hole of the printed circuit board. The second gasket can comprise an aperture configured to provide fluid communication between a vent hole of the at least one vent hole of the printed circuit board and a vent aperture of the at least one vent aperture of the outlet or exhaust mechanism through the second gasket. The at least one vent aperture of the outlet or exhaust mechanism can comprise an antibacterial membrane and/or a non-return valve. The cover layer can comprise an aperture over the at least one vent aperture. The electronics unit can comprise one or more power sources. The at least one absorbent layer can comprise one or more recesses configured to receive the electronics unit. The wound dressing can further comprising a transmission layer comprising a proximal wound-facing face and a distal face, the transmission layer can be positioned over the distal face of the wound contact layer. The at least one absorbent layer can comprise a first absorbent layer comprising a proximal

wound-facing face and a distal face, the first absorbent layer can be positioned on the distal face of the transmission layer and a second absorbent comprising a proximal wound-facing face and a distal face, the second absorbent layer can be positioned on the distal face of the first absorbent layer. The wound dressing can further comprising an overlay layer comprising a proximal wound-facing face and a distal face, the overlay layer can be positioned over the distal face of the second absorbent layer, wherein the overlay layer comprises a larger perimeter than a perimeter of the transmission layer and the first and second absorbent layer. The electronic unit can comprise a switch. The electronic unit can comprise a light or LED indicator.

**[0009]** Any of the features, components, or details of any of the arrangements or embodiments disclosed in this application, including without limitation any of the pump embodiments and any of the negative pressure wound therapy embodiments disclosed below, are interchangeably combinable with any other features, components, or details of any of the arrangements or embodiments disclosed herein to form new arrangements and embodiments.

#### BRIEF DESCRIPTION OF THE DRAWINGS

**[0010]** Figure 1A-1C illustrates a wound dressing apparatus incorporating the pump and/or other electronic components within the wound dressing and offset from the absorbent layer;

**[0011]** Figure 2A illustrate an embodiment of the electronics unit;

**[0012]** Figures 2B-2C illustrate embodiments of the pump and electronics unit;

**[0013]** Figure 3 illustrates an embodiment of a wound dressing incorporating an electronics unit within the dressing;

**[0014]** Figures 4A-4C illustrate an embodiment of a wound dressing incorporating an electronics unit in the absorbent layer;

**[0015]** Figures 5A-5B illustrate an embodiment of a wound dressing incorporating an electronics unit;

**[0016]** Figure 6 illustrates an embodiment of wound dressing layers incorporating the electronic components within the wound dressing;

**[0017]** Figures 7A-7C illustrates embodiments of individual layers of a wound dressing;

[0018] Figures 8A-8F illustrates embodiments of layers of the wound dressing incorporating an electronics assembly within the dressing;

[0019] Figure 9 illustrates a cross sectional layout of the material layers of the wound dressing incorporating an electronics assembly within the dressing

[0020] Figures 10A-10C and 11A-11B illustrate embodiments of components of an electronics unit including a printed circuit board, the negative pressure source, and one or more power sources;

[0021] Figure 12 illustrates an embodiment of a pump assembly incorporating adhesive gaskets;

[0022] Figure 13 illustrates an embodiment of a pump inlet protection mechanism; and

[0023] Figure 14 illustrates an embodiment of a pump outlet mechanism.

#### DETAILED DESCRIPTION

[0024] Embodiments disclosed herein relate to apparatuses and methods of treating a wound with reduced pressure, including a source of negative pressure and wound dressing components and apparatuses. The apparatuses and components comprising the wound overlay and packing materials, if any, are sometimes collectively referred to herein as dressings.

[0025] It will be appreciated that throughout this specification reference is made to a wound. It is to be understood that the term wound is to be broadly construed and encompasses open and closed wounds in which skin is torn, cut or punctured or where trauma causes a contusion, or any other superficial or other conditions or imperfections on the skin of a patient or otherwise that benefit from reduced pressure treatment. A wound is thus broadly defined as any damaged region of tissue where fluid may or may not be produced. Examples of such wounds include, but are not limited to, abdominal wounds or other large or incisional wounds, either as a result of surgery, trauma, sterniotomies, fasciotomies, or other conditions, dehisced wounds, acute wounds, chronic wounds, subacute and dehisced wounds, traumatic wounds, flaps and skin grafts, lacerations, abrasions, contusions, burns, diabetic ulcers, pressure ulcers, stoma, surgical wounds, trauma and venous ulcers or the like.

[0026] It will be understood that embodiments of the present disclosure are generally applicable to use in topical negative pressure ("TNP") therapy systems. Briefly, negative pressure wound therapy assists in the closure and healing of many forms of "hard to heal" wounds by reducing tissue oedema; encouraging blood flow and granular tissue formation; removing excess exudate and may reduce bacterial load (and thus infection risk). In addition, the therapy allows for less disturbance of a wound leading to more rapid healing. TNP therapy systems may also assist on the healing of surgically closed wounds by removing fluid and by helping to stabilize the tissue in the apposed position of closure. A further beneficial use of TNP therapy can be found in grafts and flaps where removal of excess fluid is important and close proximity of the graft to tissue is required in order to ensure tissue viability.

[0027] As is used herein, reduced or negative pressure levels, such as -X mmHg, represent pressure levels relative to normal ambient atmospheric pressure, which can correspond to 760 mmHg (or 1 atm, 29.93 inHg, 101.325 kPa, 14.696 psi, etc.). Accordingly, a negative pressure value of -X mmHg reflects absolute pressure that is X mmHg below 760 mmHg or, in other words, an absolute pressure of (760-X) mmHg. In addition, negative pressure that is "less" or "smaller" than X mmHg corresponds to pressure that is closer to atmospheric pressure (e.g., -40 mmHg is less than -60 mmHg). Negative pressure that is "more" or "greater" than -X mmHg corresponds to pressure that is further from atmospheric pressure (e.g., -80 mmHg is more than -60 mmHg). In some embodiments, local ambient atmospheric pressure is used as a reference point, and such local atmospheric pressure may not necessarily be, for example, 760 mmHg.

[0028] The negative pressure range for some embodiments of the present disclosure can be approximately -80 mmHg, or between about -20 mmHg and -200 mmHg. Note that these pressures are relative to normal ambient atmospheric pressure, which can be 760 mmHg. Thus, -200 mmHg would be about 560 mmHg in practical terms. In some embodiments, the pressure range can be between about -40 mmHg and -150 mmHg. Alternatively a pressure range of up to -75 mmHg, up to -80 mmHg or over -80 mmHg can be used. Also in other embodiments a pressure range of below -75 mmHg can be used. Alternatively, a pressure range of over approximately -100 mmHg, or even -150 mmHg, can be supplied by the negative pressure apparatus.

[0029] In some embodiments of wound closure devices described herein, increased wound contraction can lead to increased tissue expansion in the surrounding wound tissue. This effect may be increased by varying the force applied to the tissue, for example by varying the negative pressure applied to the wound over time, possibly in conjunction with increased tensile forces applied to the wound via embodiments of the wound closure devices. In some embodiments, negative pressure may be varied over time for example using a sinusoidal wave, square wave, and/or in synchronization with one or more patient physiological indices (e.g., heartbeat). Examples of such applications where additional disclosure relating to the preceding may be found include U.S. Patent No. 8,235,955, titled "Wound treatment apparatus and method," issued on August 7, 2012; and U.S. Patent No. 7,753,894, titled "Wound cleansing apparatus with stress," issued July 13, 2010. The disclosures of both of these patents are hereby incorporated by reference in their entirety.

[0030] International Application PCT/GB2012/000587, titled "WOUND DRESSING AND METHOD OF TREATMENT" and filed on July 12, 2012, and published as WO 2013/007973 A2 on January 17, 2013, is an application, hereby incorporated by reference in its entirety, that is directed to embodiments, methods of manufacture, and wound dressing components and wound treatment apparatuses that may be used in combination or in addition to the embodiments described herein. Additionally, embodiments of the wound dressings, wound treatment apparatuses and methods described herein may also be used in combination or in addition to those described in International Application No. PCT/IB2013/001469, filed May 22, 2013, titled "APPARATUSES AND METHODS FOR NEGATIVE PRESSURE WOUND THERAPY," published as WO 2013/175306 on November 28, 2013, US Patent Application No. 14/418874, filed January 30, 2015, published as U.S. Publication No. 2015/0216733, published August 6, 2015, titled "WOUND DRESSING AND METHOD OF TREATMENT," U.S. Patent Application No. 14/418908, filed January 30, 2015, published as U.S. Publication No. 2015/0190286, published July 9, 2015, titled "WOUND DRESSING AND METHOD OF TREATMENT," U.S. Patent Application No. 14/658,068, filed March 13, 2015, U.S. Application No. 2015/0182677, published July 2, 2015, titled "WOUND DRESSING AND METHOD OF TREATMENT," the disclosures of which are hereby incorporated by reference in their entireties. Embodiments of the wound dressings, wound treatment apparatuses and methods described herein may also be used in combination or in addition to those described in U.S. Patent

Application No. 13/092,042, filed April 21 2011, published as U.S. 2011/0282309, titled "WOUND DRESSING AND METHOD OF USE," and which is hereby incorporated by reference in its entirety, including further details relating to embodiments of wound dressings, the wound dressing components and principles, and the materials used for the wound dressings.

**[0031]** Embodiments of the wound dressings, wound treatment apparatuses and methods described herein relating to wound dressings with electronics incorporated into the dressing may also be used in combination or in addition to those described in International Application PCT/EP2017/055225, filed March 6, 2017, titled "WOUND TREATMENT APPARATUSES AND METHODS WITH NEGATIVE PRESSURE SOURCE INTEGRATED INTO WOUND DRESSING," and which is hereby incorporated by reference in its entirety, including further details relating to embodiments of wound dressings, the wound dressing components and principles, and the materials used for the wound dressings.

**[0032]** In some embodiments, a source of negative pressure (such as a pump) and some or all other components of the TNP system, such as power source(s), sensor(s), connector(s), user interface component(s) (such as button(s), switch(es), speaker(s), screen(s), etc.) and the like, can be integral with the wound dressing. The wound dressing can include various material layers described here and described in further detail in International Application No. PCT/EP2017/055225, filed March 6, 2017, entitled WOUND TREATMENT APPARATUSES AND METHODS WITH NEGATIVE PRESSURE SOURCE INTEGRATED INTO WOUND DRESSING. The material layers can include a wound contact layer, one or more absorbent layers, one or more spacer or transmission layers, and a backing layer or cover layer covering the one or more absorbent and spacer or transmission layers. The wound dressing can be placed over a wound and sealed to the wound with the pump and/or other electronic components contained under the cover layer within the wound dressing. In some embodiments, the dressing can be provided as a single article with all wound dressing elements (including the pump) pre-attached and integrated into a single unit. In some embodiments, a periphery of the wound contact layer can be attached to the periphery of the cover layer enclosing all wound dressing elements as illustrated in Figure 1A-1C.

**[0033]** In some embodiments, the pump and/or other electronic components can be configured to be positioned adjacent to or next to the absorbent and/or transmission layers so that the pump and/or other electronic components are still part of a single article to be applied to a patient. In some embodiments, with the pump and/or other electronics positioned away from the wound site. FIGS. 1A-1C illustrates a wound dressing incorporating the source of negative pressure and/or other electronic components within the wound dressing. FIGS. 1A-1C illustrates a wound dressing 100 with the pump and/or other electronics positioned away from the wound site. The wound dressing can include an electronics area 161 and an absorbent area 160. The dressing can comprise a wound contact layer 110 (not shown in FIGS. 1A-1B) and a moisture vapor permeable film or cover layer 113 positioned above the contact layer and other layers of the dressing. The wound dressing layers and components of the electronics area as well as the absorbent area can be covered by one continuous cover layer 113 as shown in FIGS. 1A-1C.

**[0034]** The dressing can comprise a wound contact layer 110, a transmission layer 111, an absorbent layer 112, a moisture vapor permeable film or cover layer 113, 113 positioned above the wound contact layer, transmission layer, absorbent layer, or other layers of the dressing. The wound contact layer can be configured to be in contact with the wound. The wound contact layer can include an adhesive on the patient facing side for securing the dressing to the surrounding skin or on the top side for securing the wound contact layer to a cover layer or other layer of the dressing. In operation, the wound contact layer can be configured to provide unidirectional flow so as to facilitate removal of exudate from the wound while blocking or substantially preventing exudate from returning to the wound.

**[0035]** The wound contact layer 110 can be a polyurethane layer or polyethylene layer or other flexible layer which is perforated, for example via a hot pin process, laser ablation process, ultrasound process or in some other way or otherwise made permeable to liquid and gas. The wound contact layer 110 has a lower surface and an upper surface. The perforations preferably comprise through holes in the wound contact layer 110 which enable fluid to flow through the layer 110. The wound contact layer 110 helps prevent tissue ingrowth into the other material of the wound dressing. Preferably, the perforations are small enough to meet this requirement while still allowing fluid to flow therethrough. For example, perforations formed as slits or holes having a size ranging from 0.025 mm to 1.2 mm are considered small enough to help prevent tissue ingrowth into the wound dressing

while allowing wound exudate to flow into the dressing. In some configurations, the wound contact layer 110 may help maintain the integrity of the entire dressing 100 while also creating an air tight seal around the absorbent pad in order to maintain negative pressure at the wound.

**[0036]** Some embodiments of the wound contact layer 110 may also act as a carrier for an optional lower and upper adhesive layer (not shown). For example, a lower pressure sensitive adhesive may be provided on the lower surface of the wound dressing 100 whilst an upper pressure sensitive adhesive layer may be provided on the upper surface of the wound contact layer. The pressure sensitive adhesive, which may be a silicone, hot melt, hydrocolloid or acrylic based adhesive or other such adhesives, may be formed on both sides or optionally on a selected one or none of the sides of the wound contact layer. When a lower pressure sensitive adhesive layer is utilized it may be helpful to adhere the wound dressing 100 to the skin around a wound site. In some embodiments, the wound contact layer may comprise perforated polyurethane film. The lower surface of the film may be provided with a silicone pressure sensitive adhesive and the upper surface may be provided with an acrylic pressure sensitive adhesive, which may help the dressing maintain its integrity. In some embodiments, a polyurethane film layer may be provided with an adhesive layer on both its upper surface and lower surface, and all three layers may be perforated together.

**[0037]** A layer 111 of porous or transmission material can be located above the wound contact layer 110. As used herein, the terms porous material, spacer, and/or transmission layer can be used interchangeably to refer to the layer of material in the dressing configured to distribute negative pressure throughout the wound area. This porous layer, or transmission layer, 111 allows transmission of fluid including liquid and gas away from a wound site into upper layers of the wound dressing. In particular, the transmission layer 111 preferably ensures that an open air channel can be maintained to communicate negative pressure over the wound area even when the absorbent layer has absorbed substantial amounts of exudates. The layer 111 should preferably remain open under the typical pressures that will be applied during negative pressure wound therapy as described above, so that the whole wound site sees an equalized negative pressure. The layer 111 may be formed of a material having a three dimensional structure. For example, a knitted or woven spacer fabric (for example Baltex 7970 weft knitted polyester) or a non-woven fabric could be used.

[0038] The transmission layer assists in distributing negative pressure over the wound site and facilitating transport of wound exudate and fluids into the wound dressing. In some embodiments, the transmission layer can be formed at least partially from a three dimensional (3D) fabric.

[0039] In some embodiments, the transmission layer 111 comprises a 3D polyester spacer fabric layer including a top layer (that is to say, a layer distal from the wound-bed in use) which is a 84/144 textured polyester, and a bottom layer (that is to say, a layer which lies proximate to the wound bed in use) which is a 10 denier flat polyester and a third layer formed sandwiched between these two layers which is a region defined by a knitted polyester viscose, cellulose or the like monofilament fiber. Other materials and other linear mass densities of fiber could of course be used.

[0040] Whilst reference is made throughout this disclosure to a monofilament fiber it will be appreciated that a multistrand alternative could of course be utilized. The top spacer fabric thus has more filaments in a yarn used to form it than the number of filaments making up the yarn used to form the bottom spacer fabric layer.

[0041] This differential between filament counts in the spaced apart layers helps control moisture flow across the transmission layer. Particularly, by having a filament count greater in the top layer, that is to say, the top layer is made from a yarn having more filaments than the yarn used in the bottom layer, liquid tends to be wicked along the top layer more than the bottom layer. In use, this differential tends to draw liquid away from the wound bed and into a central region of the dressing where the absorbent layer 112 helps lock the liquid away or itself wicks the liquid onwards towards the cover layer 113 where it can be transpired.

[0042] Preferably, to improve the liquid flow across the transmission layer 111 (that is to say perpendicular to the channel region formed between the top and bottom spacer layers), the 3D fabric may be treated with a dry cleaning agent (such as, but not limited to, Perchloro Ethylene) to help remove any manufacturing products such as mineral oils, fats or waxes used previously which might interfere with the hydrophilic capabilities of the transmission layer. In some embodiments, an additional manufacturing step can subsequently be carried in which the 3D spacer fabric is washed in a hydrophilic agent (such as, but not limited to, Feran Ice 30g/l available from the Rudolph Group). This process step helps ensure that the surface tension on the materials is so low that liquid such as water can

enter the fabric as soon as it contacts the 3D knit fabric. This also aids in controlling the flow of the liquid insult component of any exudates.

[0043] Further, an absorbent layer (such as layer 112) for absorbing and retaining exudate aspirated from the wound can be utilized. In some embodiments, a superabsorbent material can be used in the absorbent layer 112. In some embodiments, the absorbent includes a shaped form of a superabsorber layer.

[0044] A layer 112 of absorbent material is provided above the transmission layer 111. The absorbent material, which comprise a foam or non-woven natural or synthetic material, and which may optionally comprise a super-absorbent material, forms a reservoir for fluid, particularly liquid, removed from the wound site. In some embodiments, the layer 111 may also aid in drawing fluids towards the cover layer 113.

[0045] The material of the absorbent layer 112 may also prevent liquid collected in the wound dressing from flowing freely within the dressing, and preferably acts so as to contain any liquid collected within the dressing. The absorbent layer 112 also helps distribute fluid throughout the layer via a wicking action so that fluid is drawn from the wound site and stored throughout the absorbent layer. This helps prevent agglomeration in areas of the absorbent layer. The capacity of the absorbent material must be sufficient to manage the exudates flow rate of a wound when negative pressure is applied. Since in use the absorbent layer experiences negative pressures the material of the absorbent layer is chosen to absorb liquid under such circumstances. A number of materials exist that are able to absorb liquid when under negative pressure, for example superabsorber material. The absorbent layer 112 may typically be manufactured from ALLEVYN™ foam, Freudenberg 114-224-4 or Chem-Posite™11C-450. In some embodiments, the absorbent layer 112 may comprise a composite comprising superabsorbent powder, fibrous material such as cellulose, and bonding fibers. In a preferred embodiment, the composite is an airlaid, thermally-bonded composite.

[0046] In some embodiments, the absorbent layer 112 is a layer of non-woven cellulose fibers having super-absorbent material in the form of dry particles dispersed throughout. Use of the cellulose fibers introduces fast wicking elements which help quickly and evenly distribute liquid taken up by the dressing. The juxtaposition of multiple strand-like fibers leads to strong capillary action in the fibrous pad which helps distribute liquid. In this way, the super-absorbent material is efficiently supplied with liquid. The wicking action

also assists in bringing liquid into contact with the upper cover layer to aid increase transpiration rates of the dressing.

[0047] The wound dressing layers of the electronics area and the absorbent layer can be covered by one continuous cover layer or backing layer 113. As used herein, the terms cover layer and/or backing layer can be used interchangeably to refer to the layer of material in the dressing configured to cover the underlying dressing layers and seal to the wound contact layer and/or the skin surrounding the wound. In some embodiments, the cover layer can include a moisture vapor permeable material that prevents liquid exudate removed from the wound and other liquids from passing through, while allowing gases through.

[0048] The cover layer 113 is preferably gas impermeable, but moisture vapor permeable, and can extend across the width of the wound dressing 100. The cover layer 113, which may for example be a polyurethane film (for example, Elastollan SP9109) having a pressure sensitive adhesive on one side, is impermeable to gas and this layer thus operates to cover the wound and to seal a wound cavity over which the wound dressing is placed. In this way an effective chamber is made between the cover layer 113 and a wound site where a negative pressure can be established. The cover layer 113 is preferably sealed to the wound contact layer 110 in a border region around the circumference of the dressing, ensuring that no air is drawn in through the border area, for example via adhesive or welding techniques. The cover layer 113 protects the wound from external bacterial contamination (bacterial barrier) and allows liquid from wound exudates to be transferred through the layer and evaporated from the film outer surface. The cover layer 113 preferably comprises two layers; a polyurethane film and an adhesive pattern spread onto the film. The polyurethane film is preferably moisture vapor permeable and may be manufactured from a material that has an increased water transmission rate when wet. In some embodiments, the moisture vapor permeability of the cover layer increases when the cover layer becomes wet. The moisture vapor permeability of the wet cover layer may be up to about ten times more than the moisture vapor permeability of the dry cover layer.

[0049] The electronics area 161 can include a source of negative pressure (such as a pump) and some or all other components of the TNP system, such as power source(s), sensor(s), connector(s), user interface component(s) (such as button(s), switch(es), speaker(s), screen(s), etc.) and the like, that can be integral with the wound dressing. For example, the electronics area 161 can include a button or switch 114 as shown in FIGS. 1A-

1B. The button or switch 114 can be used for operating the pump (e.g., turning the pump on/off).

**[0050]** The absorbent area 160 can include an absorbent material 112 and can be positioned over the wound site. The electronics area 161 can be positioned away from the wound site, such as by being located off to the side from the absorbent area 160. The electronics area 161 can be positioned adjacent to and in fluid communication with the absorbent area 160 as shown in FIGS. 1A-1C. In some embodiments, each of the electronics area 161 and absorbent area 160 may be rectangular in shape and positioned adjacent to one another. In some embodiments, the electronics unit can be within absorbent material in the electronics area 160 of the dressing as described herein. As illustrated in Figure 1C, the electronics unit can be positioned within the absorbent material but off to the side of the absorbent area.

**[0051]** In some embodiments, additional layers of dressing material can be included in the electronics area 161, the absorbent area 160, or both areas. In some embodiments, the dressing can comprise one or more transmission layers and/or one or more absorbent layer positioned above the wound contact layer 110 and below the cover layer 113 of the dressing.

**[0052]** In some embodiments, the electronics area 161 of the dressing can comprise electronic components 150. In some embodiments, the electronics area 161 of the dressing can comprise a plurality of layers of transmission material and/or absorbent material and electronic components 150 can be embedded within the plurality of layers of transmission material and/or absorbent material. The layers of transmission or absorbent material can have recesses or cut outs to embed the electronic components 150 within whilst providing structure to prevent collapse. The electronic components 150 can include a pump, power source, controller, and/or an electronics package.

**[0053]** A pump exhaust can be provided to exhaust air from the pump to the outside of the dressing. The pump exhaust can be in communication with the electronics area 161 and the outside of the dressing.

**[0054]** As used herein the upper layer, top layer, or layer above refers to a layer furthest from the surface of the skin or wound while the dressing is in use and positioned over the wound. Accordingly, the lower surface, lower layer, bottom layer, or layer below refers to the layer that is closest to the surface of the skin or wound while the dressing is in

use and positioned over the wound. Additionally, the layers can have a proximal wound-facing face referring to a side or face of the layer closest to the skin or wound and a distal face referring to a side or face of the layer furthest from the skin or wound.

**[0055]** Figure 1A-1C illustrates a wound dressing apparatus incorporating the pump and/or other electronic components within the wound dressing and offset from the absorbent layer. In some embodiments, as shown in Figure 1C, the absorbent area 160 comprises a transmission layer 111 positioned above the wound contact layer 110. An absorbent layer 112 can be provided above the transmission layer 111. In some embodiments, the electronics area 161 can include an electronics unit (shown in Figures 2A-2C). In some embodiments, the electronics unit is provided directly over the wound contact layer. In other embodiments, the electronics unit can be placed above a layer of wicking material, absorbent material, or transmission material that sits above the wound contact layer 110 of the dressing. For example, as shown in Figure 1C, the electronics unit 150 may be positioned over the transmission layer 111. In some embodiments, the transmission layer 111 can be a single layer of material extending below the electronics unit 150 and the absorbent material 112. Thus, in some embodiments, the transmission layer 111 extends continuously through the absorbent area 160 and the electronics area 161. In alternative embodiments, the transmission layer below the electronics unit can be a different transmission layer than the transmission layer below the absorbent material 112. The transmission layer 111, absorbent material 112, and electronics unit 150 can be covered with a cover layer 113 that seals to a perimeter of the wound contact layer 110 as shown in Figures 1A-1C.

**[0056]** The electronics area 161 can include an electronics unit 150 positioned below the cover layer 113 of the dressing. In some embodiments, the electronics unit can be surrounded by a material to enclose or encapsulate a negative pressure source and electronics components by surrounding the electronics. In some embodiments, this material can be a casing. In some embodiments, the electronics unit can be encapsulated or surrounded by a protective coating, for example, a hydrophobic coating as described herein. The electronics unit can be in contact with the dressing layers in the absorbent area 160 and covered by the cover layer 113. As used herein, the electronics unit includes a lower or wound facing surface that is closest to the wound and an opposite, upper surface, furthest from the wound when the wound dressing is placed over a wound.

[0057] Figure 2A illustrate an embodiment of the electronics unit 267. Figure 2A illustrates an embodiment of a pump and electronics unit 267 that can be incorporated into a wound dressing. The electronics unit 267 of Figure 2A is shown without an electronics casing or other dressing material. Figures 2B-2C illustrate embodiments of the pump and electronics unit 267. Figure 2B illustrates the top view of the electronics unit. Figure 2C illustrates a bottom or wound facing surface of the electronics unit.

[0058] As illustrated in Figure 2A-2B, the electronics unit 267 can include single button 265 on the upper surface of the unit. The single button 265 can be used as an on/off button or switch to stop and start operation of the pump and/or electronic components. The switch 265 can be a dome type switch configured to sit on the top of the pump. Because the switch is situated within the dressing the cover layer can be easily sealed around or over the switch. In some embodiments, the cover layer can have an opening or hole positioned above the switch. The cover layer can be sealed to the outer perimeter of the switch 265 to maintain negative pressure under the wound cover. The switch can be placed on any surface of the electronics unit and can be in electrical connection with the pump.

[0059] The electronics unit 267 can also include one or more vents or exhausts 264 for the pump outlet. However, the vent or exhaust 264 is positioned at the outlet of the pump and extending to the upper surface of the electronics unit. As shown in Figure 2A, the pump outlet exhaust 264 is attached to the outlet of the pump and provides communication with the top surface of the dressing. In some embodiments, the exhaust 264 can be attached to the outlet end of the pump and can extend out from the pump at a 90-degree angle from the pump orientation to communicate with the top surface of the dressing. The exhaust 264 can include an antibacterial membrane and a non-return valve. The exhausted air from the pump can pass through the pump outlet and exhaust mechanism 274. In some embodiments, the cover layer 113 can include apertures or holes positioned above the exhaust vents 264 and/or membrane. The cover layer 113 can be sealed to the outer perimeter of the exhaust vents 264 to maintain negative pressure under the wound cover 113. In some embodiments, the exhausted air can be exhausted through the gas permeable material or moisture vapor permeable material of the cover layer. In some embodiments, the cover layer does not need to contain apertures or holes over the exhaust and the exhausted air is expelled through the cover layer. In some embodiments, the pump outlet mechanism 274 can be a custom part formed to fit around the pump as shown in Figure 2A-2C. The electronic unit 267 can

include a pump inlet protection mechanism 280 (shown in Figure 2C) positioned on the portion of the electronic unit closest to the absorbent area and aligned with the inlet of the pump 272. The pump inlet protection mechanism is positioned between the pump inlet and the absorbent area or absorbent layer of the dressing. The pump inlet protection mechanism can be formed of a hydrophobic material to prevent fluid from entering the pump.

**[0060]** In some embodiments, the upper surface of the electronics unit can include one or more indicators 266 for indicating a condition of the pump and/or level of pressure within the dressing. The indicators can be small LED lights or other light source that are visible through the dressing material or through holes in the dressing material above the indicators. The indicators can be green, yellow, red, orange, or any other color. For example, there can be two lights, one green light and one orange light. The green light can indicate the device is working properly and the orange light can indicate that there is some issue with the pump (e.g. dressing leak, saturation level of the dressing, and/or low battery).

**[0061]** Figure 2A-2C illustrates an embodiment of a pump and electronics unit 267. The electronics unit 267 can include a pump 272 and one or more batteries 268 or other power source to power the pump 272 and other electronics. The pump can operate at about 27 volts or about 30 volts. The two batteries can allow for a more efficient voltage increase (6 volts to 30 volts) than would be possible with a single battery.

**[0062]** The batteries 268 can be in electrical communication with a flexible circuit board 276. In some embodiments, one or more battery connections are connected to a surface of the flexible circuit board 276. In some embodiments, the flexible circuit board can have other electronics incorporated within. For example, the flexible circuit board may have various sensors including, but not limited to, one or more pressure sensors, temperature sensors, optic sensors and/or cameras, and/or saturation indicators.

**[0063]** In such embodiments, the components of the electronics unit 267 may include a protective coating to protect the electronics from the fluid within the dressing. The coating can provide a means of fluid separation between the electronics unit 267 and the absorbent materials of the dressing. The coating can be a hydrophobic coating including, but not limited to, a silicone coating or polyurethane coating. The pump inlet component can be used to protect the pump from fluid on the inlet and the pump outlet mechanism can include a non-return valve that protects fluid from entering the outlet as described in more detail with reference to PCT International Application No. PCT/EP2017/055225, filed March 6, 2017,

titled WOUND TREATMENT APPARATUSES AND METHODS WITH NEGATIVE PRESSURE SOURCE INTEGRATED INTO WOUND DRESSING and PCT International Application No. PCT/EP2017/059883, filed April 26, 2017, titled WOUND DRESSINGS AND METHODS OF USE WITH INTEGRATED NEGATIVE PRESSURE SOURCE HAVING A FLUID INGRESS INHIBITION COMPONENT, which is hereby incorporated by reference in its entirety.

**[0064]** The electronics unit 267 includes one or more slits, grooves or recesses 271 in the unit between the pump and the two batteries. The slits, grooves or recesses 271 can allow for the electronics unit 267 to be flexible and conform to the shape of the wound. The unit 267 can have two parallel slits, grooves or recesses 271 forming three segments of the electronics unit 267. The slits, grooves or recesses 271 of the unit 267 create hinge points or gaps that allows for flexibility of the electronics unit at that hinge point. The pump exhaust vents 264, switch 265, and indicator 266 are shown on the top surface surrounded by the electronics unit 267. As illustrated, one embodiment of the electronics unit 267 has two hinge points to separate the unit into three regions or panels, for example one to contain one battery, one to contain the pump, and one to contain another battery. In some embodiments, the slits, grooves or recesses may extend parallel with a longitudinal axis of the dressing that extends along the length of the dressing through the electronics area of the dressing through the absorbent area of the dressing.

**[0065]** Figure 3 illustrates an embodiment of a wound dressing incorporating an electronics unit 367 within the dressing. In some embodiments, the wound dressing can include a wound contact layer 304. The dressing can also include a transmission layer 305 which may be made of a 3D material above the wound contact layer. In some embodiments, the electronics sub assembly or electronics unit 367 can be embedded in an aperture or hole in an absorbent pad 302 towards one end of the dressing, as depicted in Figure 3. As shown in the cross sectional view of the wound dressing layers in Figure 3, the absorbent material 302 can be positioned on both sides of the electronic components 367.

**[0066]** In some embodiments, the absorbent components in the absorbent area 360 can be adjacent to or offset from the electronics unit 367 in the electronics area 361 as illustrated in Figure 3. In some embodiments, the absorbent components and electronics components can be overlapping but offset. For example, a portion of the electronics area 361 can overlap the absorbent area 360, for example overlapping the superabsorber layer, but the

electronics area 361 is not completely over the absorbent area 360. Therefore, a portion of the electronics area can be offset from the absorbent area. The dressing layer and electronic components can be enclosed in a wound contact layer 304 positioned below the lower most layer and a cover layer (not shown) positioned above the absorbent layer and electronics. The wound contact layer and cover layer can be sealed at a perimeter enclosing the dressing components. In some embodiments, the cover layer can be in direct physical contact with the absorbent material, and/or the electronics unit. In some embodiments, the cover layer can be sealed to a portion of the electronics unit and/or casing, for example, in areas where holes or apertures are used to accommodate the electronic components (e.g. a switch and/or exhaust).

[0067] Figures 4A-4C illustrate an embodiment of a wound dressing incorporating an electronics unit resting in the absorbent layer. Figure 4A illustrates a transmission layer 401. Figure 4B illustrates an absorbent layer 402 provided over the entire length of the transmission layer 401. The absorbent layer has one recess, cutout, or slot 407 in the portion of the absorbent layer 402 located in the electronics area. In Figure 4B, the transmission layer 401 is visible in the recess 407 of the absorbent layer 402. The recess 407 is spaced and sized to fit the outer perimeter of the batteries and pump assembly of the electronics unit 404 (as shown in Figure 4C) in one recess. In some embodiments, the recess in the absorbent layer can include multiple recesses that are sized to fit individual components of the electronics unit 404, for example, the batteries and pump assembly as illustrated in embodiments described with reference to Figures 6, 7A-7C, and 8A-8F. Figure 4C illustrates the electronics unit 404 positioned within the recess 407 of the absorbent layer 402. The dressing layers and components shown in Figure 4C can be enclosed in a wound contact layer (not shown) positioned below the transmission layer and a cover layer (not shown) positioned above the absorbent layer and electronics. The wound contact layer and cover layer can be sealed at a perimeter enclosing the dressing components.

[0068] The wound dressing of Figures 5A-5B include an overlay layer 517 comprising an additional layer of material positioned above the dressing layers. In some embodiments, the additional layer can include a masking or obscuring layer positioned above the dressing layers. The overlay layer 517 can be positioned above the absorbent layer and electronics and below the cover layer 513. In some embodiments, the overlay layer 517 can include an aperture 540 over a portion of the electronic components to allow the electronic components to be accessible from above the overlay layer. In some embodiments, the overlay

layer 517 can be an opaque material that does not allow the wound exudate or other fluid to be visible from a top view of the wound dressing. In some embodiments, the overlay layer can be an absorbent or transmission layer as described herein. In some embodiments, the overlay layer can comprise a conformable material overlaying and overbordering the perimeter of the lower layers of transmission and absorbent materials so as to protect the cover layer from being punctured by the lower layers when sealed over the dressing layers as described in more details below.

**[0069]** The wound dressing can include an electronics label or covering 541 positioned over the aperture 540 in the overlay layer 517. In some embodiments, the label or covering 541 can be positioned under the cover layer 513. In other embodiments, the cover layer 513 can be positioned below the label and can also have an aperture to allow the label or covering 541 to communicate with the underlying electronic components.

**[0070]** Figure 5B illustrate the wound dressing of Figure 5A absorbing and retaining fluids while negative pressure is applied to the dressing.

**[0071]** Figures 5A-5B illustrate a label or covering 541 that can be positioned over and cover the electronics and an opening 540 in the overlay layer 517

**[0072]** Figure 6 illustrates an embodiment of wound dressing layers incorporating the electronic components within the wound dressing. Figure 6 illustrates a wound dressing with a wound contact layer 610 configured to contact the wound. A transmission layer or spacer layer 611 is provided over the wound contact layer 610. The transmission layer 611 can assist in transmitting and distributing negative pressure over the wound site.

**[0073]** A first layer of apertured absorbent material 651 can be provided over the transmission layer 611. The first apertured absorbent layer 651 can include an aperture 629. In some embodiments, the aperture 629 can be sized and shaped to fit the electronics unit 650 therein. The first apertured absorbent layer 651 can be sized and shaped to the size of the electronics area and does not extend into the absorbent area. In some embodiments, the apertures 629 can be shaped and sized to fit the individual components of the electronics unit 650.

**[0074]** A second apertured absorbent layer 622 can be provided over the first absorbent layer 651. In some embodiments, the second absorbent layer 622 include apertures 628. The second absorbent layer 622 can be sized and shaped to the size of the electronics

area and absorbent area. In some embodiments, the apertures 628 can be shaped and sized to fit the individual components of the electronics unit 650.

[0075] An electronics unit 650 can be positioned in the apertures 628 and 629 of the first and second apertured absorbent material 651 and 622. The electronics unit 650 can include a pump 627, power source 626, and a printed circuit board 681. In some embodiments, the pump 627 can include a pump inlet mechanism 1710 and an outlet mechanism 682. In some embodiments, the printed circuit board 681 can include electronics including but not limited to a switch, sensors, and LEDs as described herein. In some embodiments, the circuit board 681 can include one or more hole to be positioned over one or more exhaust vents (not shown) in the outlet mechanism 682 as described in more detail herein.

[0076] An overlay layer 617 can be provided over the electronics components 650 and absorbent layer 622. In some embodiments, the overlay layer 617 can be one or more layers of absorbent and/or transmission material as described herein. In some embodiments, the overlay layer 617 can comprise a conformable material overlaying and overbordering the perimeter of the lower layers of transmission and absorbent materials. In some embodiments, the overlay layer 617 can soften the edges of the wound dressing layers by decreasing the profile around the edges of the dressing layers. In some embodiments, the overlay layer 617 can be provided to protect the cover layer from being punctured by the lower layers when positioned over the dressing layers as described in more details below. The overlay layer 617 can include an aperture 671 to allow access to at least a portion of the electronics unit 650 positioned below.

[0077] A cover layer or backing layer 613 can be positioned over the overlay layer 617. In some embodiments, when the overlay layer 617 is not used, the cover layer or backing layer 613 can be provided above absorbent layers 622, and/or electronic components 650. The cover layer 613 can form a seal to the wound contact layer 610 at a perimeter region enclosing the overlay layer 617, absorbent layers 622 and 651, electronic components 650, and the transmission layer 611. In some embodiments, the cover layer 613 can be a flexible sheet of material that forms and molds around the dressing components when they are applied to the wound. In other embodiments, the cover layer 613 can be a material that is preformed or premolded to fit around the dressing components. As used herein, the terms

cover layer and backing layer can be used interchangeably to refer to the layer of material in the dressing configured to cover the layers of the wound dressing.

**[0078]** In some embodiments, the cover layer or backing layer 613 can include an aperture 672. The aperture 672 can be positioned over at least a portion of the aperture 671 in the overlay layer 617 to allow access to at least a portion of the electronics unit 650 positioned below. In some embodiments, the apertures 671 and 672 can allow access to the switch and/or venting holes of the pump exhaust.

**[0079]** A label 641 can be provided over the apertures 671 and 672 and positioned over the exposed portion of the electronic components 650. The label can include the vent holes 642, indicator portions 644, and/or switch cover 643. The indicator portions 644 can include holes or transparent regions 644 for positioning over the one or more indicators or LEDs on the printed circuit board 681 below the label 641. The holes or transparent regions 644 can allow for the indicators or LEDs to be visible through the label 641. In some embodiments, the switch cover 642 can include a dome shaped cover positioned over the switch on the printed circuit board 681. In some embodiments, the label 641 can include embossed features for the switch cover 642. In some embodiments, the embossed features of the switch cover 642 can prevent accidental activation or deactivation of the device. In some embodiments, the switch or switch cover 642 can include a tab on the switch to prevent accidental activation or deactivation. The vent holes 642 of the label can allow exhaust from the pump outlet mechanism to pass through the label and exit the wound dressing to be exhausted to the atmosphere.

**[0080]** In some embodiments, the label can be positioned on top of the cover layer or backing layer 613. The label can be sealed to the top surface of the cover layer. In other embodiments, the label 641 can be positioned above the overlay layer 671 and below the cover layer or backing layer 613. In such embodiments, the cover layer 613 can have one or more apertures over one or more components of the label 641. For example, the cover layer 613 can have apertures over the vent holes 642, indicator portions 644, and/or switch cover 643.

**[0081]** Figures 7A-7C illustrates the individual layers of a wound dressing. Figure 7A illustrates a first apertured absorbent material 751 cut to fit the size and shape of the electronics area.

[0082] Figure 7B illustrates a second apertured absorbent layer 722 and a transmission layer 711. Both the second absorbent layer 722 and transmission layer 711 can be a similar size and shape as shown in Figure 7B. The first apertured absorbent material 751 can be a smaller apertured absorbent material than the size of the second apertured absorbent layer 722.

[0083] Figure 7C illustrates a transmission layer 711, a first apertured absorbent layer 751, a second apertured absorbent layer 722, and overlay layer 717. As shown in Figure 7C, the overlay layer 717 can have a larger perimeter size than the other layers of the dressing as to overhang the edges of the other layers of the wound dressing. In some embodiments, the overlay layer 717 can have a smaller thickness than the absorbent layer 722 and transmission layer 711. In other embodiments, the overlay layer 717 can have the same thickness or a greater thickness than the absorbent layer 722 and transmission layer 711.

[0084] Figures 8A-8F illustrates the layers of the wound dressing incorporating an electronics assembly within the dressing. As shown in Figure 8A, a transmission layer 711 can be placed over a wound contact layer 710. Figure 8B illustrates a bottom view of components of the wound dressing. Figure 8B illustrates the bottom view of an electronic unit 750 embedded within the apertures of the first apertured absorbent layer 751 and the second apertured absorbent layer 722. Figure 8C illustrates a top view of an electronics unit 750 embedded within the apertures of the first apertured absorbent layer 751 (not shown) and the second apertured absorbent layer 722 placed over the transmission layer (not shown) and the wound contact layer 710.

[0085] Figure 8D illustrates the layers of the wound dressing device with the electronics unit 750 embedded within the first apertured absorbent layer 751 and the second apertured absorbent layer 722. The first apertured absorbent layer 751 and the second apertured absorbent layer 722 can be placed over the transmission layer 711 and the wound contact layer 710.

[0086] Figure 8E illustrates an overlay layer 717 positioned over the dressing layers. The overlay layer 717 includes an opening or aperture 740 positioned over a portion of the electronics unit 750. The aperture 740 can allow for access to the switch, pump outlet components, and visual indicators on the top surface of the electronics unit 750.

[0087] A label or covering 741 can be positioned over and cover the electronics and an opening 740 in the overlay layer 717 as shown in Figure 8F. Figure 8F shows a cover layer 713 covering the overlay layer 717 and electronics covering 741 and underlying dressing and electronics components. The cover layer 713 can seal to the wound contact layer 710 (shown in Fig. 8C-8E) at a perimeter region of the wound contact layer 710. In some embodiments, the label or electronics covering 741 can be positioned over the cover layer 713. In some embodiments, the cover layer 713 can seal over the electronics covering 741. In some embodiments, the electronics covering 741 can include a switch cover 743, one or more visual indicators 744, and/or pump outlet vent(s) 742 as shown in Figure 8F. In some embodiments, the cover layer 713 can include one or more holes in the cover layer 713 positioned over the switch and/or pump outlet vent(s). In some embodiments, the cover layer 713 can include a single hole that is positioned over the switch cover 743, visual indicators 744, and/or pump outlet vent(s) 742 in the covering or label 741 as shown in Figure 8F. In some embodiments, the label can include embossed features for the switch cover 743. In some embodiments, the embossed features of the switch cover 743 can prevent accidental activation or deactivation of the device. In some embodiments, the switch or switch cover 743 can include a tab on the switch to prevent accidental activation or deactivation.

[0088] The visual indicators 744 can provide an indication of operation of the negative pressure source and/or an indication of the level of negative pressure that is applied to the wound. In some embodiments, the visual indicators can include one or more light sources or LEDs. In some embodiments, the visual indicator light sources can illuminate to indicate a condition or change of condition. In some embodiments, the light source can illuminate in a particular sequence and/or color that indicates a condition. For example, in some embodiments, the light source can flash to notify the user that the device is operating properly. In some embodiments, the light source can automatically flash periodically and/or the light source can be activated by the switch or other button to light up and indicate a condition.

[0089] In some embodiments, the switch can be pressed and/or held down to power the dressing and electronics on and off. In some embodiments, once the switch is activated and the pump and associated colored LED, for example, green colored LED, can be used to confirm the dressing and integrated negative pressure source is operational. In

some embodiments, during operation of the pump and dressing, the pump and dressing can enter the fault state indicated by a colored LED, for example, orange colored LED.

[0090] The electronics components can be incorporated in the dressing. For example, the dressing components can be assembled to form one integrated negative pressure dressing to be positioned over a wound. The following assembly description describes an embodiment of the assembly of an integrated wound dressing. In some embodiments, some or all of the assembly process can be automated and/or any or all of the processes or procedures can be done in any order.

[0091] A transmission layer can be positioned over the wound contact layer as shown in Figure 8A. In some embodiments, the transmission layer can be positioned with the larger pores facing upward or away from the wound. Figure 8B illustrates a bottom view of some of the components of the wound dressing to illustrate the electronic components embedded within or fit into the apertures of the large apertured pad or absorbent layer and small apertured pad or absorbent layer. In Figure 8B, the electronics assembly is positioned switch side down. Figure 8C illustrates the top view of the electronics assembly within the apertured pads or absorbent material placed directly on top of the transmission layer as shown in Figures 8C and 8D. The switch can be positioned on the top surface of the printed circuit board as shown in Figures 8C and 8D.

[0092] The overlay layer 717 can be positioned over the apertured pads or absorbent material with the aperture in the overlay layer positioned over the switch of the electronics assembly. In some embodiments, the edges and/or the outer perimeter of the overlay layer 717 can be adhered or secured to the top or upper surface of the wound contact layer 710. A top film or cover layer can be placed over the overlay layer 717 as shown in Figure 8F. In some embodiments, the perimeter of the cover layer can be secured to the top or upper surface of the wound contact layer 710. In some embodiments, if the cover layer is positioned over the printed circuit board, holes can be punctured in the top film at the location of the two exhaust ports. In other embodiments, the cover layer is provided with one or more apertures that are placed over the two exhaust ports and/or other components of the electronics unit.

[0093] A label cover can be applied over the switch and/or other components of the electronics assembly that are exposed through the apertures of the overlay layer 717 and the cover layer. The indicator portions can include transparent portions or LED windows

aligned with the LED's on the PCB when the label cover is applied. In some embodiments, the LED windows can include apertures in the label cover. In other embodiments, the LED windows can be transparent portions of the label cover. The exhaust holes can also be aligned with apertures in the label cover.

[0094] Figure 9 illustrates a cross sectional layout of the material layers of the wound dressing incorporating an electronics assembly within the dressing. The dressing 900 included multiple material layers and an electronics assembly 950. The wound dressing 900 can include an electronics area 961 including the electronics and an absorbent area or dressing area 960 that is intended to be applied to the wound as described with reference to Figures 1A-1B. As described herein, the one or more of the material layers can extend into both the electronics area 961 and the dressing area 960. The dressing 900 can include a wound contact layer 910, transmission layer 911, absorbent layers 922 and 951, an overlay layer, and a cover or backing layer 913 as illustrated in Figure 9. The absorbent layers 922 and 951 can include recesses or cutouts to receive the components of the electronics assembly 950 as described herein. In some embodiments, the overlay layer 917 and/or the cover layer 913 can include a cut out over the switch and/or indicators of the electronics assembly 950. A label or covering 941 can be positioned to cover at least a portion of the electronics assembly 950 and any cutouts in the overlay layer 917 and/or the cover layer 913. The label or covering 941 can be similar to the label or covering 741 as described previously with reference to Figures 6 and 8F.

[0095] Before use, the dressing can include a delivery layer 945 adhered to the bottom surface of the wound contact layer. The delivery layer 945 can cover adhesive or apertures on the bottom surface of the wound contact layer 910. In some embodiments, the delivery layer 945 can provided support for the dressing and can assist in sterile and appropriate placement of the dressing over the wound and skin of the patient. The delivery layer 945 can include handles 946 that can be used by the user to separate the delivery layer 945 from the wound contact layer 910 before applying the dressing 900 to a wound and skin of a patient.

#### Electronics Unit

[0096] The negative pressure wound therapy wound dressing described herein utilizes an embedded electronic circuit assembly to generate the negative pressure under the dressing. It can be important to protect the assembly from wound exudate or any other bodily

fluid that would corrode the electronics. In addition, it can be important to protect the patient from the electric or electronic components. The assembly incorporates a pump which pulls air from the dressing to exhaust to the environment in order to produce the required negative pressure differential. Therefore, the means of protection of the electronics cannot be a complete encapsulation or potting of the assembly. The protection must allow movement of air from the dressing to the pump and exhausting the dressing to the environment. In addition, as a component of the electronic assembly, it is essential to protect the pump from bodily fluids. It can be helpful to provide a sealed electronics unit where components are protected from bodily fluids and environmental conditions and also allow for communication with the wound dressing layers and the external environment. Additionally, it can be useful to allow the electronic components integrated within the wound dressing to incorporate control circuitry and sensors to measure and determine negative pressure applied to the wound.

[0097] In some embodiments, the electronics unit requiring protection from the environment of the wound dressing can be partially encapsulated, potted or conformally coated. In some embodiments, the electronics unit can include a printed circuit board (PCB) 1081, the negative pressure source 1072, and one or more power sources 1068 as shown in Figures 10A and 10B. In some embodiments, the entirety of the electronics unit except for the pump inlet and pump outlet can be coated in a potted silicon enclosure. In some embodiments, potting of electronic components can include a process of filling a complete electronic assembly with a solid or gelatinous compound for resistance to shock and vibration, exclusion of moisture, and/or exclusion of corrosive agents.

[0098] Figures 10A-10C illustrates the pump assembly system 1500 with the pump inlet protection mechanism 1710 and pump outlet mechanism 1074 on the pump 1072. The pump assembly system 1500 can include cavities 1082 shown on the pump inlet protection mechanism 1710 and pump outlet mechanism 1074. In some embodiments, the inlet protection and pump outlet mechanisms can be adhered to the inlet and the outlet of the pump as described herein. In some embodiments, the pump assembly system 1500 can be assembled using an adhesive and allowed to cure prior to incorporating into the electronics assembly.

[0099] The pump inlet can be covered or fitted with a pump inlet protection mechanism 1710. In some embodiments, the pump inlet protection 1710 can be pushed onto

the pump inlet as illustrated by the arrows in Figure 11A. This can be a friction fit. The port of the pump inlet protection 1710 that receives a portion of the pump inlet can be sized and shaped to be a complementary fit around the pump inlet. In some embodiments, the pump inlet protection 1710 can be bonded onto the pump inlet using a silicone sealant or any other sealant or sealing technique. Figure 11B illustrates the pump inlet protection mechanism 1710 covering the pump inlet and the pump outlet mechanism 1074 covering the pump outlet. The pump outlet mechanism 1074 can include vent holes 1084 to allow air exhausted from the pump to be exhausted from the pump outlet mechanism 1074. In some embodiments, the pump outlet mechanism 1074 can also include an exhaust vent hole 1084 in communication with a nonreturn valve and/or filter membrane of the pump outlet mechanism.

**[0100]** Figures 11A-11B illustrate a pump inlet protection mechanism 1710 and pump outlet mechanism 1074 with cavities 1082. The pump assembly including the pump inlet protection mechanism 1710 and pump outlet mechanism 1074 are placed over the surface of the printed circuit board 1081. When the pump assembly is in contact with the surface of the printed circuit board 1081, the cavities 1082 can be positioned over sensors on the printed circuit board 1081, for example, pressure sensors 1091 and 1092 on the printed circuit board 1081 illustrated in Figure 10B. As used herein the terms pump exhaust mechanism and pump outlet mechanism can be used interchangeably to refer to the component or mechanism 1074 positioned on the outlet of the pump.

**[0101]** The pressure sensors can be used on the printed circuit board to measure and monitor the pressure levels produced by the pump as well as the pressure differential between the atmospheric pressure and the pressure underneath the wound dressing. Figure 10B illustrates a first pressure sensor 1091 and a second pressure sensor 1092 on the printed circuit board 1081. The first pressure sensor 1091 can be used to monitor pressure underneath the wound dressing, such as pressure in a fluid flow path connecting the negative pressure source or pump 1072 and the wound, pressure at the wound, or pressure in the negative pressure source 1072. In some embodiments, the first pressure sensor 1091 can be in fluid communication with the cavity 1082 of the pump inlet protection mechanism 1710 shown in Figures 11A-11B.

**[0102]** The second pressure sensor 1092 can be used to monitor pressure external to the wound dressing. In some embodiments, the second pressure sensor 1092 can be in

fluid communication with the cavity 1082 of the pump outlet mechanism 1074 shown in Figures 11A-11B. The pressure external to the wound dressing can be atmospheric pressure; however, the atmospheric pressure can vary depending on, for instance, an altitude of use or pressurized environment in which the TNP apparatus may be used.

**[0103]** The control circuitry of the PCB can control the supply of negative pressure by the negative pressure source 1072 according at least to a comparison between the pressure monitored by the first pressure sensor 1091 and the pressure monitored by the second pressure sensor 1092. In some embodiments, the control circuitry can vary the sampling rate at which pressures monitored by the first and second pressure sensors 1091 and 1092 are sampled, such as based at least on an amount of energy stored in the power source 1068 or whether the negative pressure source 1072 is supplying negative pressure. The sampling rate can be varied, for instance, to increase an amount of power consumed (that is, by increasing the sampling rate) or decrease an amount of power consumed (that is, by decreasing the sampling rate) by the control circuitry. A controller of the control circuitry can enter a sleep mode, which may be a mode during which the pressure monitored by the first and second pressure sensors 1091 and 1092 is not sampled, and the controller can vary the sampling rate by entering the sleep mode. The sleep mode may be a mode from which the controller can be awoken via a hardware or software interrupt. Embodiments of the wound dressings, wound treatment apparatuses and methods described herein may also be used in combination or in addition to those described in more detail with reference to PCT International Application No. PCT/EP2017/060464, filed May 3, 2017, titled NEGATIVE PRESSURE WOUND THERAPY DEVICE ACTIVATION AND CONTROL, which is hereby incorporated by reference in its entirety herein.

**[0104]** In some embodiments, a self-adhesive gasket 1711 and 1712 can be applied to the pump inlet protection 1710 and pump exhaust mechanism 1074 that seals the cavities 1082 of the pump inlet and pump exhaust around sensors on the printed circuit board 1081 and to seal around the exhaust mechanism vent holes and corresponding vent holes in the printed circuit board as illustrated in FIG. 12. In some embodiments, a pre-formed adhesive sheet can be used to form the sealing gaskets between the cavities 1082 of the pump inlet and pump exhaust mechanisms and sensors on the printed circuit board 1081 and between the exhaust mechanism vent holes and vent holes in the printed circuit board. In other embodiments, an adhesive can be used to seal the cavities 1082 of the pump inlet

protection 1710 and pump exhaust mechanism 1074 around sensors on the printed circuit board 1081 and to seal around the exhaust mechanism vent holes 1084 and corresponding vent holes in the printed circuit board. Figure 10B illustrates an embodiment of adhesive applied to the printed circuit board 1081 for adhering the pump inlet and pump exhaust mechanism to the printed circuit board 1081. In some embodiments, the electronics unit can be embedded within layers of the dressing in the electronics area 1361 as described previously. In some embodiments, the layers of the dressing in the electronics area 1361 can include cutouts or recesses into which the electronics unit can be placed.

**[0105]** The pump inlet component can be used to protect the pump from fluid on the inlet and the pump outlet mechanism can include a non-return valve that protects fluid from entering the outlet as described in more detail with reference to PCT International Application No. PCT/EP2017/055225, filed March 6, 2017, titled WOUND TREATMENT APPARATUSES AND METHODS WITH NEGATIVE PRESSURE SOURCE INTEGRATED INTO WOUND DRESSING and PCT International Application No. PCT/EP2017/059883, filed April 26, 2017, titled WOUND DRESSINGS AND METHODS OF USE WITH INTEGRATED NEGATIVE PRESSURE SOURCE HAVING A FLUID INGRESS INHIBITION COMPONENT, which are hereby incorporated by reference in their entireties herein.

**[0106]** In some embodiments, the pump inlet protection mechanism 1710 can have a cavity 1082 to surround the sensor or other feature on the printed circuit board as shown in Figure 13. The pump inlet protection mechanism can provide a large surface area available for vacuum to be drawn by the inlet of the pump. The pump inlet can fit within the recess 1083 in the pump inlet protection mechanism 1710 illustrated in Figure 13. The pump inlet can be friction fit and/or form a complementary fit with the recess 1083 of the pump inlet protection mechanism as described herein. The pump inlet protection mechanism can have a rounded beveled shape or any other shape. The pump inlet protection mechanism can be formed from a porous material that allows for air or gas to pass through and can comprise one or more porous polymer molded components. In some embodiments, the pump inlet protection mechanism can be hydrophobic. In some embodiments, the pump inlet protection mechanism can have a pore size in the range of approximately 5 microns to approximately 40 microns. In some embodiments, the pore size can be approximately 10 microns. In some embodiments, the polymer can be one of hydrophobic polyethylene or hydrophobic

polypropylene. In some embodiments, the pump inlet protection mechanism can be formed from a Porvair Vyton material with a pore size of 10 microns.

**[0107]** In some embodiments, the pump outlet mechanism can include a non-return valve as shown in Figure 14. In some embodiments, the pump outlet mechanism can be bonded to the outlet of the pump using a sealant, for example a silicone sealant. The non-return valve can be similar to non-return valve described in PCT International Application No. PCT/EP2017/055225 incorporated by reference herein. As illustrated in Figure 14, the non-return valve 1410 can include a reed valve or loose leaf valve. In some embodiments, the non-return valve 1410 can be any suitable mechanical one-way valve, such as, for example, a reed valve, a duckbill valve, a ball valve, or an umbrella valve, among others. In some embodiments, the outlet or exhaust of the pump outlet mechanism can include an antimicrobial film and/or other filter membrane. In some embodiments, the antimicrobial film or membrane can filter the air exhausted from the pump to the atmosphere.

**[0108]** In some embodiments, the pressure sensor(s) positioned on the printed circuit board aligned with the cavity of the pump inlet protection mechanism can be used to measure a pressure at the inlet of the pump or the inlet air flow. In some embodiments, the pressure sensor(s) positioned on the printed circuit board aligned with the cavity of the pump outlet mechanism can be used to measure a pressure at the outlet of the pump or the atmospheric air.

**[0109]** In some embodiments, software can be loaded onto the PCB. In some embodiments, the pump assembly 1500 including the pump inlet protection mechanism and the pump outlet mechanism can be soldered, adhered, or otherwise attached to the PCB. When self-adhesive gaskets are used between the pump assembly and PCB, the release liner can be pulled from the gaskets and the pump assembly can be pressed to the PCB to form a seal. In some embodiments, as illustrated in Figure 10B, a thin bead of gasket sealant can be applied around the two pressure sensors and the exhaust aperture in the PCB and the pump assembly can be pressed to the PCB to form a seal. In some embodiments, both self-adhesive gaskets and the gasket sealant can be used. In some embodiments, the device utilizes either the self-adhesive gaskets or the gasket sealant.

**[0110]** The batteries can be soldered or attached to the PBC ensuring the terminals are in the correct orientation as illustrated in Figure 10A. In some embodiments, a piece of foam or self-adhesive foam tape can be applied to the face of one or more batteries.

[0111] In some embodiments, a metal clicker dome can be fixed at the switch position on the PCB. In some embodiments, the clicker dome can be fixed or sealed to the PCB using an adhesive.

[0112] In some embodiment, a conformal coating can be applied to the electronics sub assembly to provide electrical and mechanical isolation of the electronics from the patient, components of the wound dressing, and exudate in the wound dressing. In some embodiments, liberal silicone coating can be applied to the electronics sub assembly. In some embodiments, the switch and LED's can remain uncoated. In some embodiments, the PCB edges can be coated. The coated assembly can be cured and inspected to confirm there are no defects in the coating. In some embodiments, more than one coating can be applied to the assembly to confirm coating of all the appropriate components.

[0113] The assembled electronics components can be incorporated in the dressing as described above. For example, the dressing components can be assembled to form one integrated negative pressure dressing to be positioned over a wound.

[0114] In some embodiments, the label and electronic components can be designed to provide mechanical and electrical isolation from the other areas of the dressing and from the patient. In some embodiments, the electrical isolation can be formed providing distance between the electronic components and the label cover. In some embodiments, electrical isolation can be provided through the coating and/or encapsulating the pump or other electrical components with an electrical isolating material. The electrical isolating material can include, but is not limited to, paint, foil, encapsulation with a conformable coating, and/or any other conductive material. In some embodiments, the electrical components can be encapsulated or coated with titanium to electrical isolate the electronic components. In some embodiments, the label can be formed from, coated with, or covered with the electrical isolating material. For example, the bottom surface of the label, in communication with the electronic components can be coated or covered with the electrical isolating material. In some embodiments, the top and/or bottom of the electrical components and/or label can be coated or covered with the electrical isolating material. The wound dressing with integrated electronic components as described herein can be defibrillation proof.

[0115] The wound dressing with embedded electronics can be any shape or size to accommodate various types of wounds. For example, the wound dressing with embedded

electronics can have a rectangular, rounded rectangular, square, T shaped, or any other shape or design. In some embodiments, the wound dressings with embedded electronics described herein can be rectangular or rounded rectangular shaped as illustrated with reference to Figures 1A-2B. In other embodiments, the wound dressings with embedded electronics described herein can be a T shaped as illustrated with reference to Figures 4A-8F.

**[0116]** All of the features disclosed in this specification (including any accompanying exhibits, claims, abstract and drawings), and/or all of the steps of any method or process so disclosed, may be combined in any combination, except combinations where at least some of such features and/or steps are mutually exclusive. The disclosure is not restricted to the details of any foregoing embodiments. The disclosure extends to any novel one, or any novel combination, of the features disclosed in this specification (including any accompanying claims, abstract and drawings), or to any novel one, or any novel combination, of the steps of any method or process so disclosed.

**[0117]** Various modifications to the implementations described in this disclosure may be readily apparent to those skilled in the art, and the generic principles defined herein may be applied to other implementations without departing from the spirit or scope of this disclosure. Thus, the disclosure is not intended to be limited to the implementations shown herein, but is to be accorded the widest scope consistent with the principles and features disclosed herein. Certain embodiments of the disclosure are encompassed in the claim set listed below or presented in the future.

**[0118]** It is to be understood that, if any prior art publication is referred to herein, such reference does not constitute an admission that the publication forms a part of the common general knowledge in the art, in Australia or any other country.

**[0119]** In the claims which follow and in the preceding description of the invention, except where the context requires otherwise due to express language or necessary implication, the word “comprise” or variations such as “comprises” or “comprising” is used in an inclusive sense, i.e. to specify the presence of the stated features but not to preclude the presence or addition of further features in various embodiments of the invention.

## CLAIMS

The claims defining the invention are as follows:

1. A wound dressing apparatus comprising:
  - a wound contact layer comprising a proximal wound-facing face and a distal face, wherein the proximal wound-facing face is configured to be positioned in contact with a wound;
  - at least one absorbent layer over the wound contact layer; and
  - an electronics unit comprising:
    - a negative pressure source unit comprising a negative pressure source, a pump inlet protection mechanism, and a pump outlet or exhaust mechanism;
    - a plurality of sensors positioned on a printed circuit board,
    - wherein the pump inlet protection mechanism comprises a first cavity configured to surround a first sensor on the printed circuit board, and a first recess configured to receive an inlet port of the negative pressure source;
    - wherein the pump outlet or exhaust mechanism comprises a second cavity configured to surround a second sensor on the printed circuit board,
    - wherein the at least one absorbent layer is configured to be in fluid communication with the electronics unit; and
    - a cover layer configured to cover and form a seal over the wound contact layer and the at least one absorbent layer.
2. The wound dressing apparatus of claim 1, wherein the pump inlet protection mechanism comprises a porous molded component comprising the first cavity and the first recess spaced from the first cavity.
3. The wound dressing apparatus of claim 1 or claim 2, wherein the pump outlet or exhaust mechanism comprises a vent hole configured to allow air exhausted from the negative pressure source to be exhausted from the pump outlet or exhaust mechanism.
4. The wound dressing apparatus of claim 3, wherein a perimeter of the first cavity comprises a first gasket configured to seal the perimeter of the first cavity in the porous molded component to the printed circuit board around the first sensor.

5. The wound dressing apparatus of claim 3, wherein a perimeter of the second cavity comprises a second gasket configured to seal the perimeter of the second cavity of the pump outlet or exhaust mechanism to the printed circuit board around the second sensor.

6. The wound dressing apparatus of claim 5, wherein the printed circuit board comprises at least one vent hole in the printed circuit board, wherein the vent hole of the outlet or exhaust mechanism is configured to be in fluid communication with the at least one vent hole of the printed circuit board.

7. The wound dressing apparatus of claim 6, wherein the second gasket comprises an aperture configured to provide fluid communication between a first vent hole of the at least one vent hole of the printed circuit board and the vent hole of the pump outlet or exhaust mechanism through the second gasket.

8. The wound dressing apparatus of claim 4 or claim 5, wherein the vent hole of the outlet or exhaust mechanism comprises an antibacterial membrane and/or a non-return valve.

9. The wound dressing apparatus of claim 6 or claim 7, wherein the cover layer comprises an aperture over the at least one vent hole in the printed circuit board.

10. The wound dressing apparatus of any one of the preceding claims, wherein the electronics unit comprises one or more power sources.

11. The wound dressing apparatus of any one of the preceding claims, wherein the at least one absorbent layer comprises one or more recesses configured to receive the electronics unit.

12. The wound dressing apparatus of any one of the preceding claims, further comprising a transmission layer comprising a proximal wound-facing face and a distal face, the transmission layer positioned over the distal face of the wound contact layer.

13. The wound dressing apparatus of claim 12, wherein the at least one absorbent layer comprises:

a first absorbent layer comprising a proximal wound-facing face and a distal face, the first absorbent layer positioned on the distal face of the transmission layer; and

a second absorbent layer comprising a proximal wound-facing face and a distal face, the second absorbent layer positioned on the distal face of the first absorbent layer.

14. The wound dressing apparatus of claim 13, further comprising an overlay layer comprising a proximal wound-facing face and a distal face, the overlay layer positioned over the distal face of the second absorbent layer, wherein the overlay layer comprises a larger perimeter than a perimeter of the transmission layer and the first and second absorbent layer.

15. The wound dressing apparatus of any one of the preceding claims, wherein the electronic unit comprises a switch.

16. The wound dressing apparatus of any one of the preceding claims, wherein the electronic unit comprises a light or LED indicator.

17. The wound dressing apparatus of any one of the preceding claims, wherein the pump inlet protection mechanism and the pump outlet or exhaust mechanism are removably attached to opposite ends of the negative pressure source.

18. The wound dressing apparatus of any one of claims 1-17, wherein the pump inlet protection mechanism and the negative pressure source are coplanar.

19. The wound dressing apparatus of any one of claims 1-17, wherein the pump outlet or exhaust mechanism and the negative pressure source are coplanar.

20. The wound dressing apparatus of any one of claims 1-19, wherein an edge of the pump inlet protection mechanism abuts a first complementary edge of the negative pressure source forming a complementary fit between the pump inlet protection mechanism and the negative pressure source.

21. The wound dressing apparatus of any one of claims 1-19, wherein an edge of the pump outlet or exhaust mechanism abuts a second complementary edge of the negative pressure source forming a complementary fit between the pump outlet or exhaust mechanism and the negative pressure source.

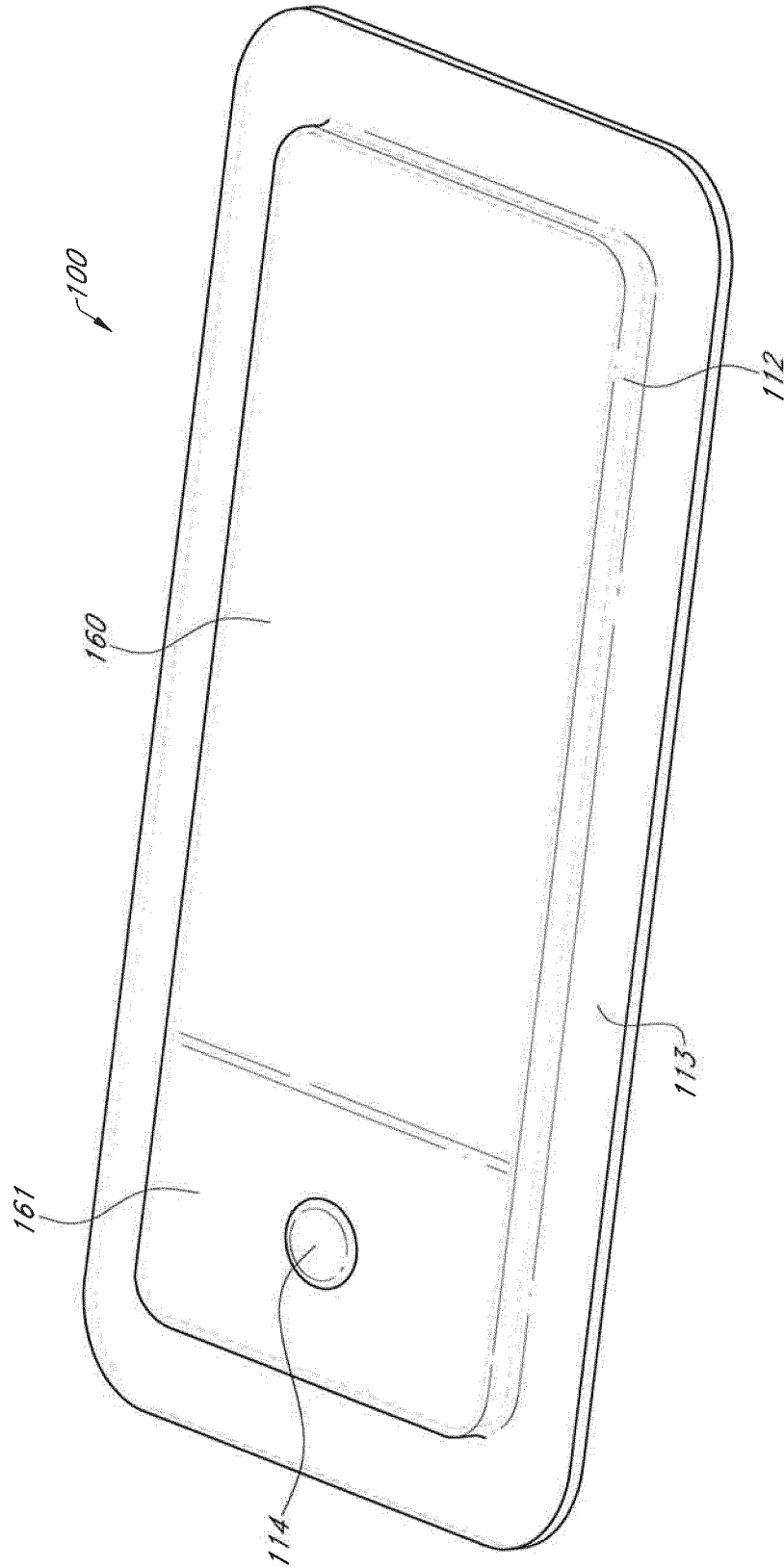

FIG. 1A

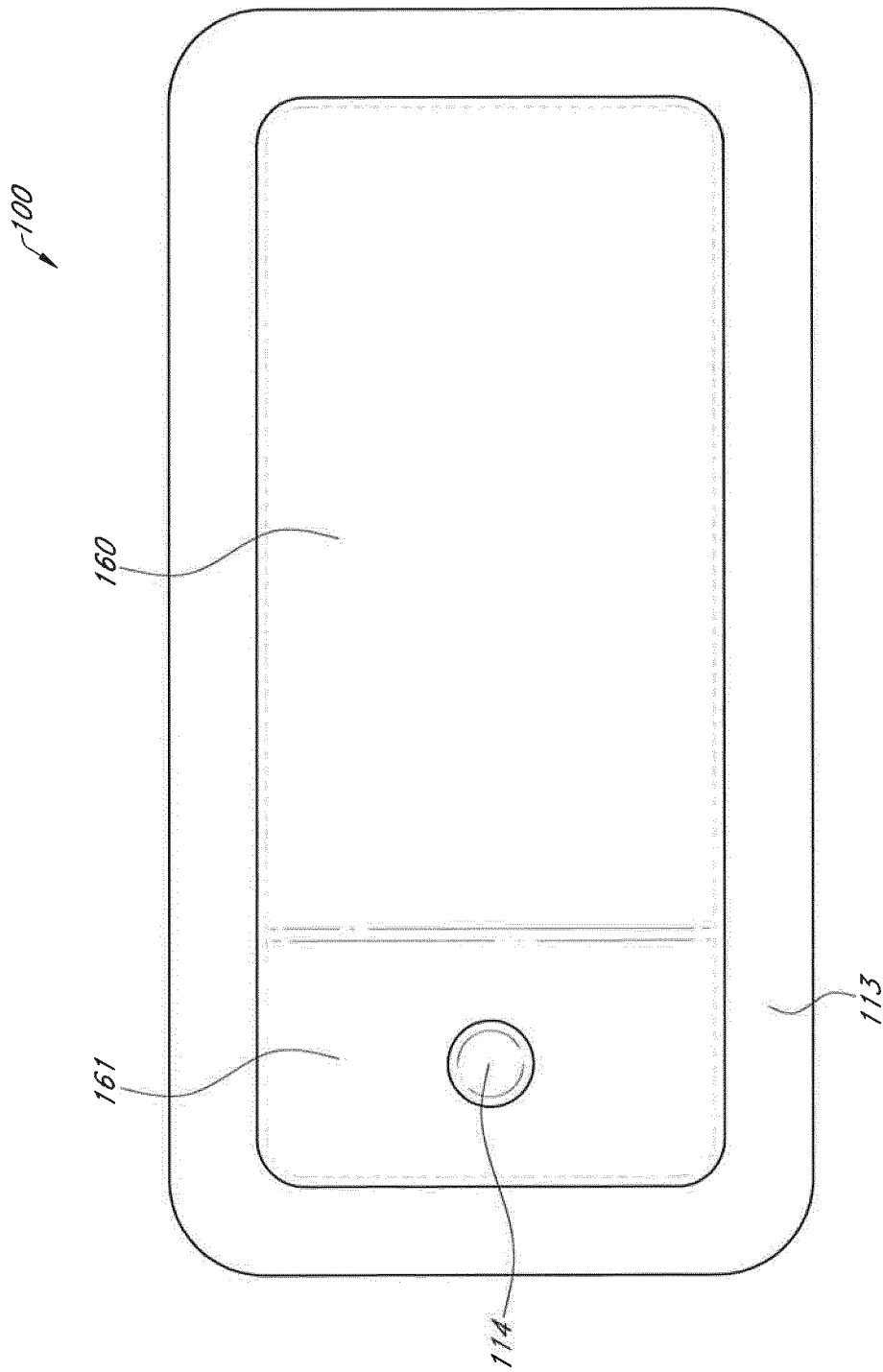

FIG. 1B

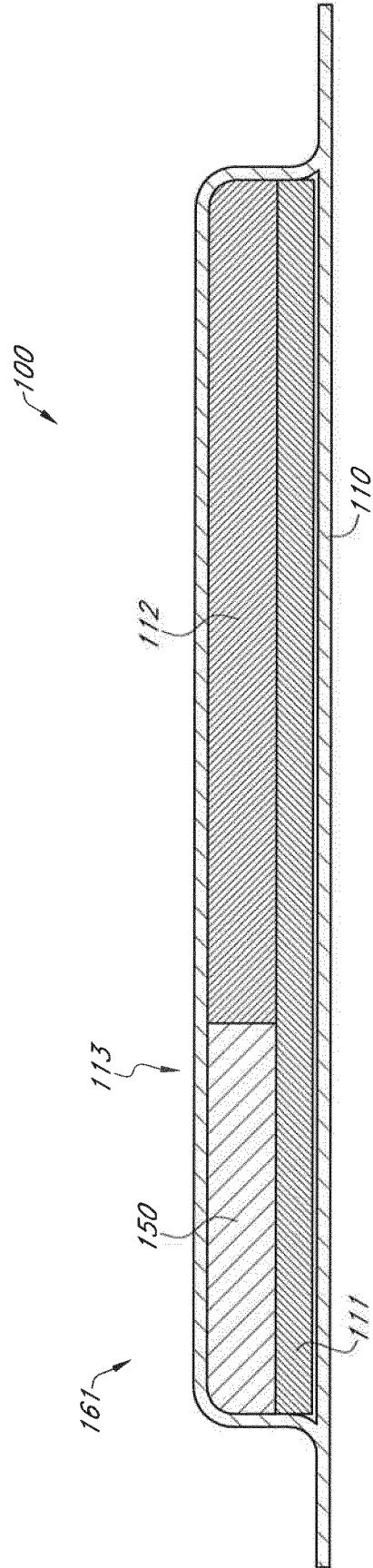

FIG. 1C

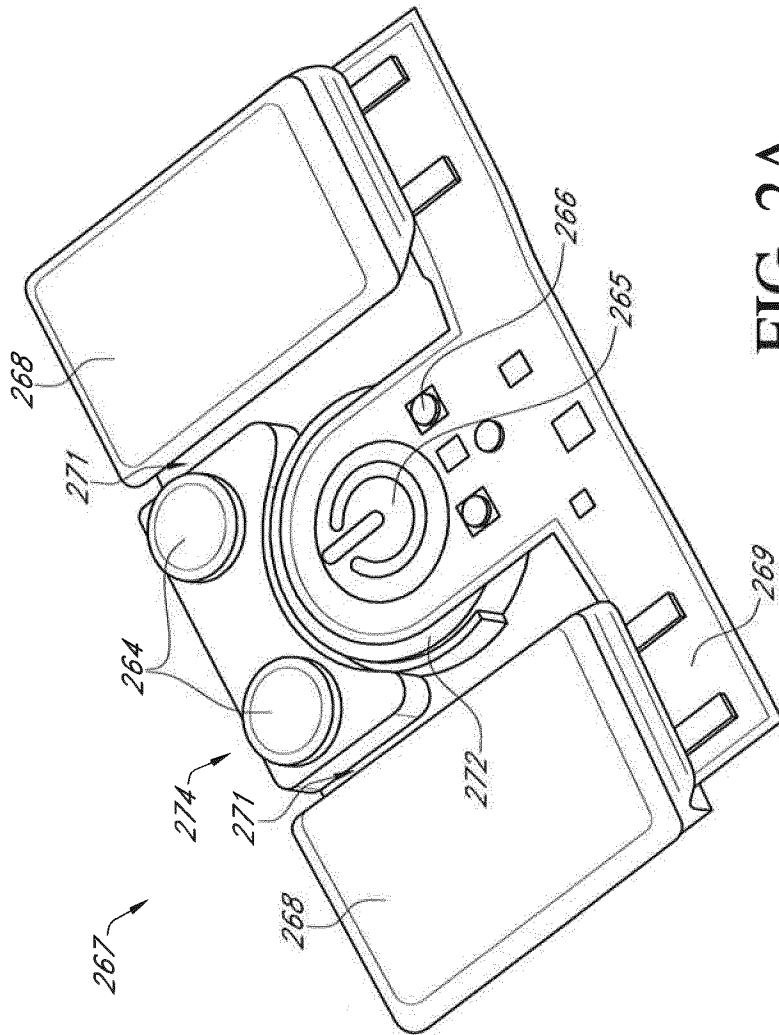

FIG. 2A

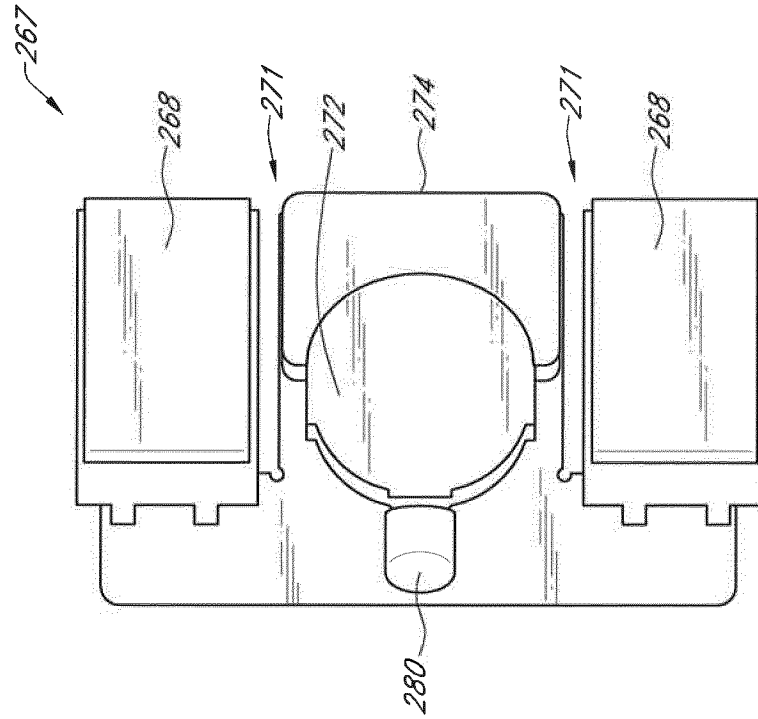

FIG. 2C

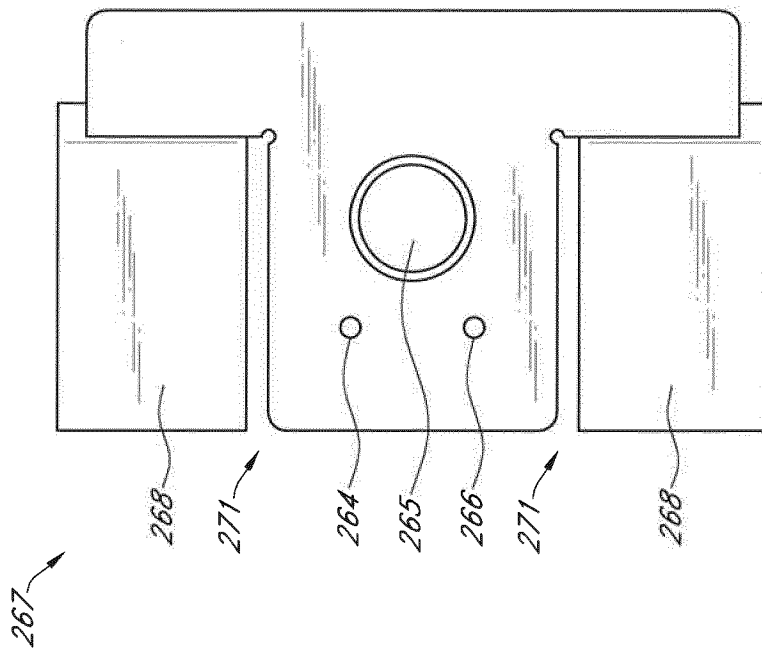

FIG. 2B

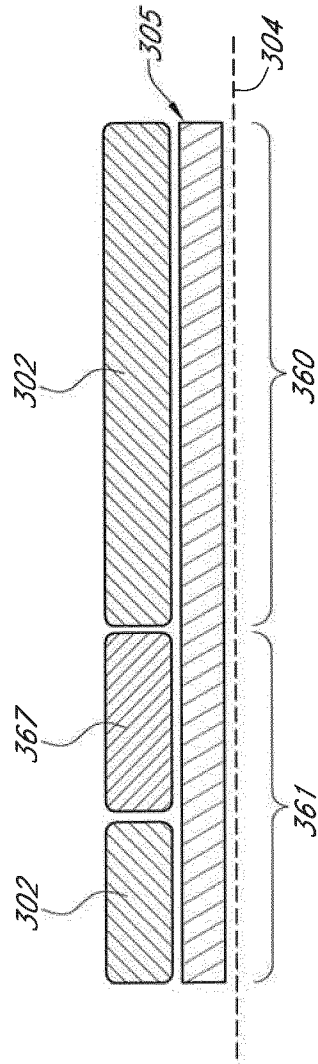

FIG. 3

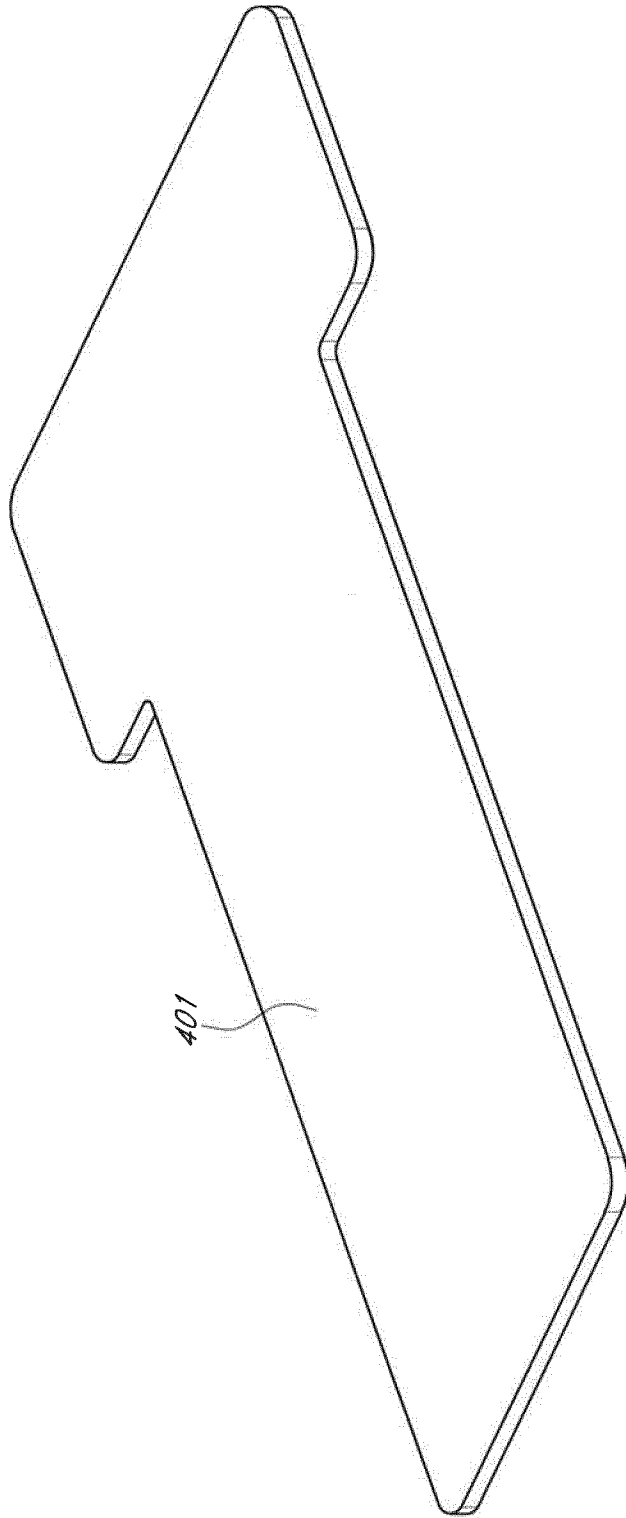

FIG. 4A

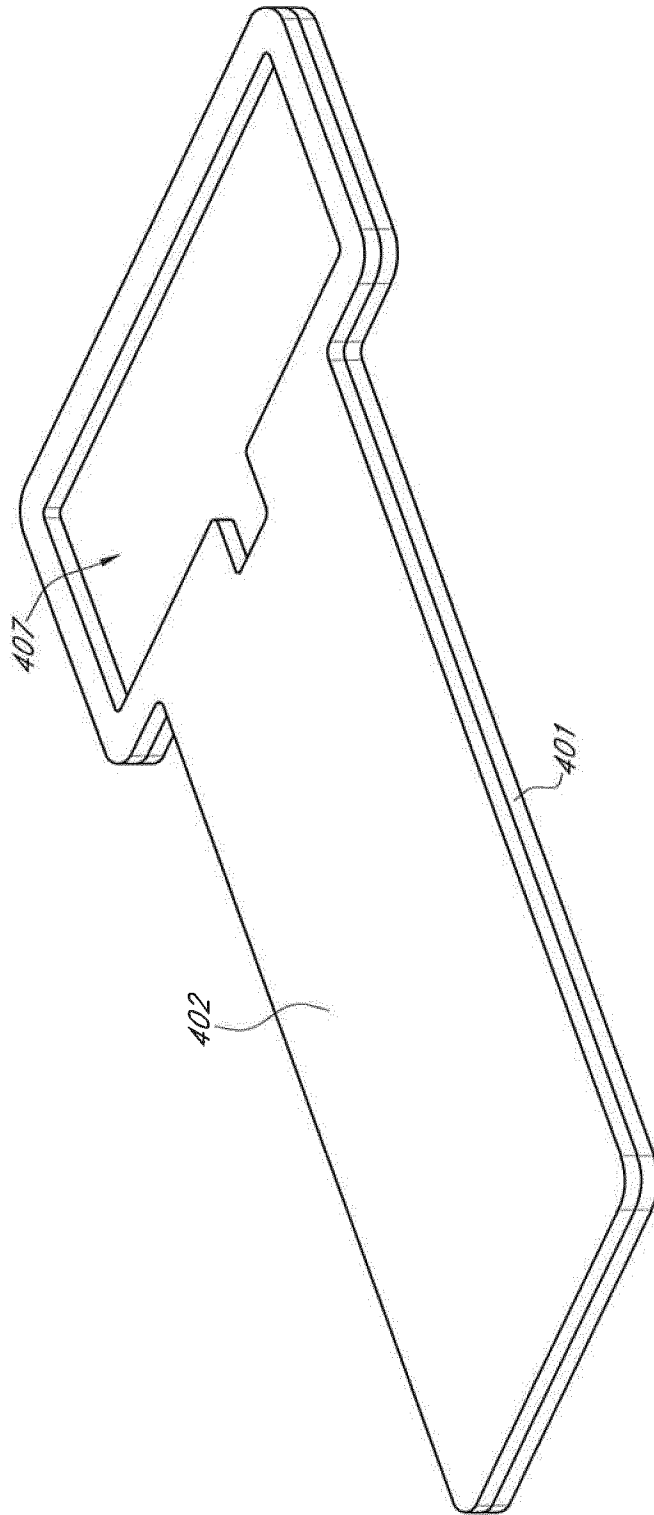

FIG. 4B

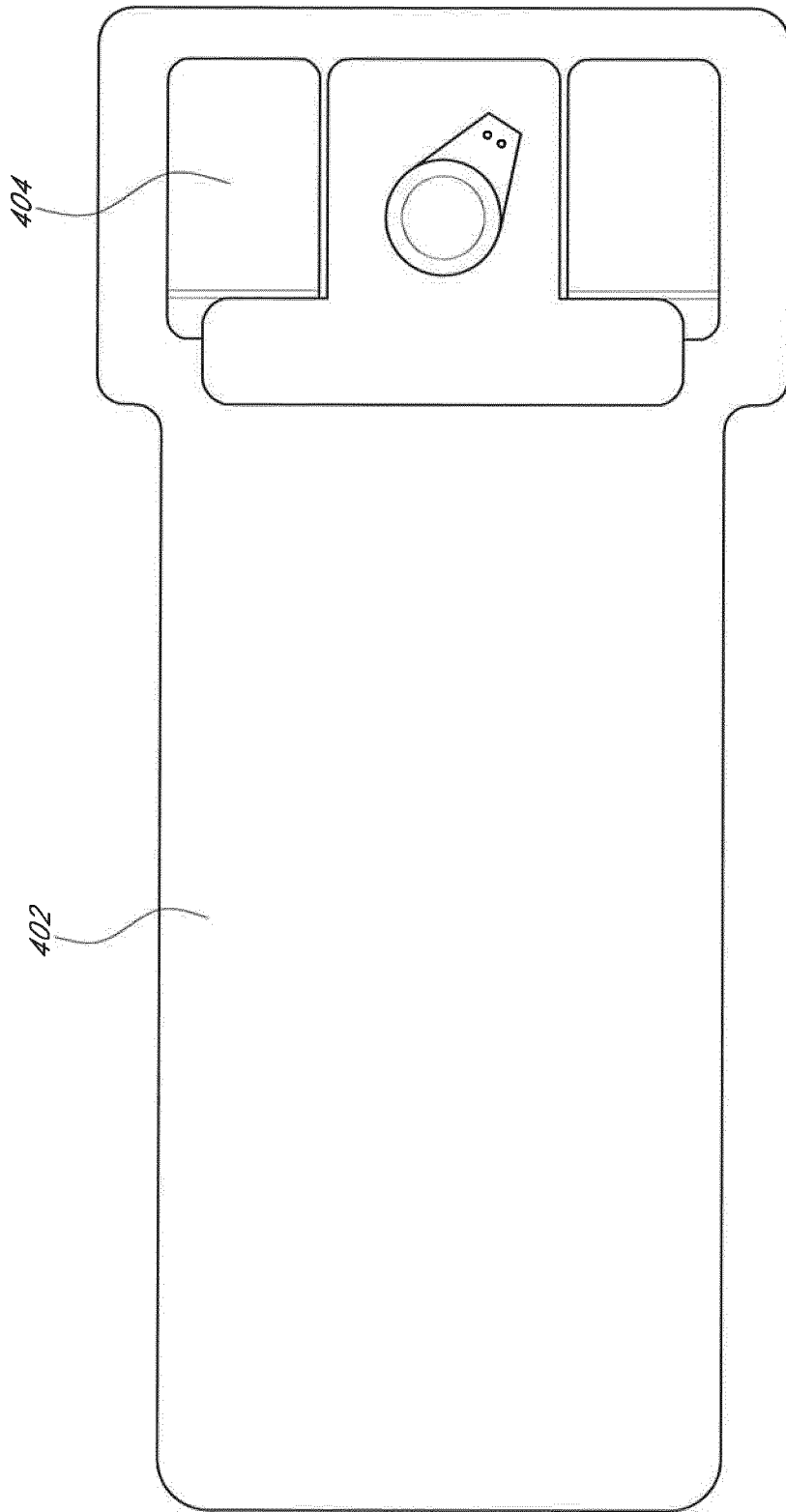

FIG. 4C

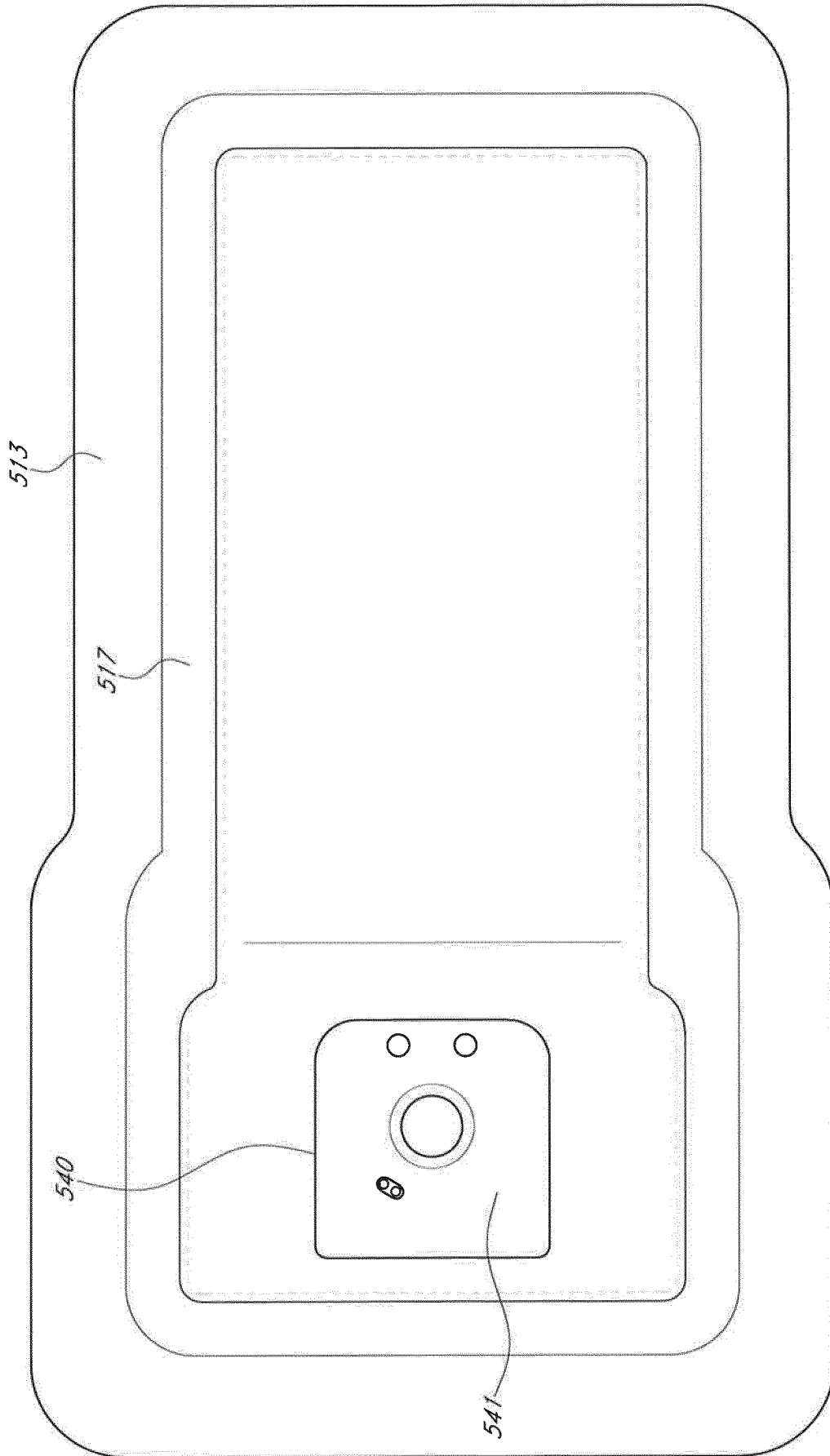

FIG. 5A

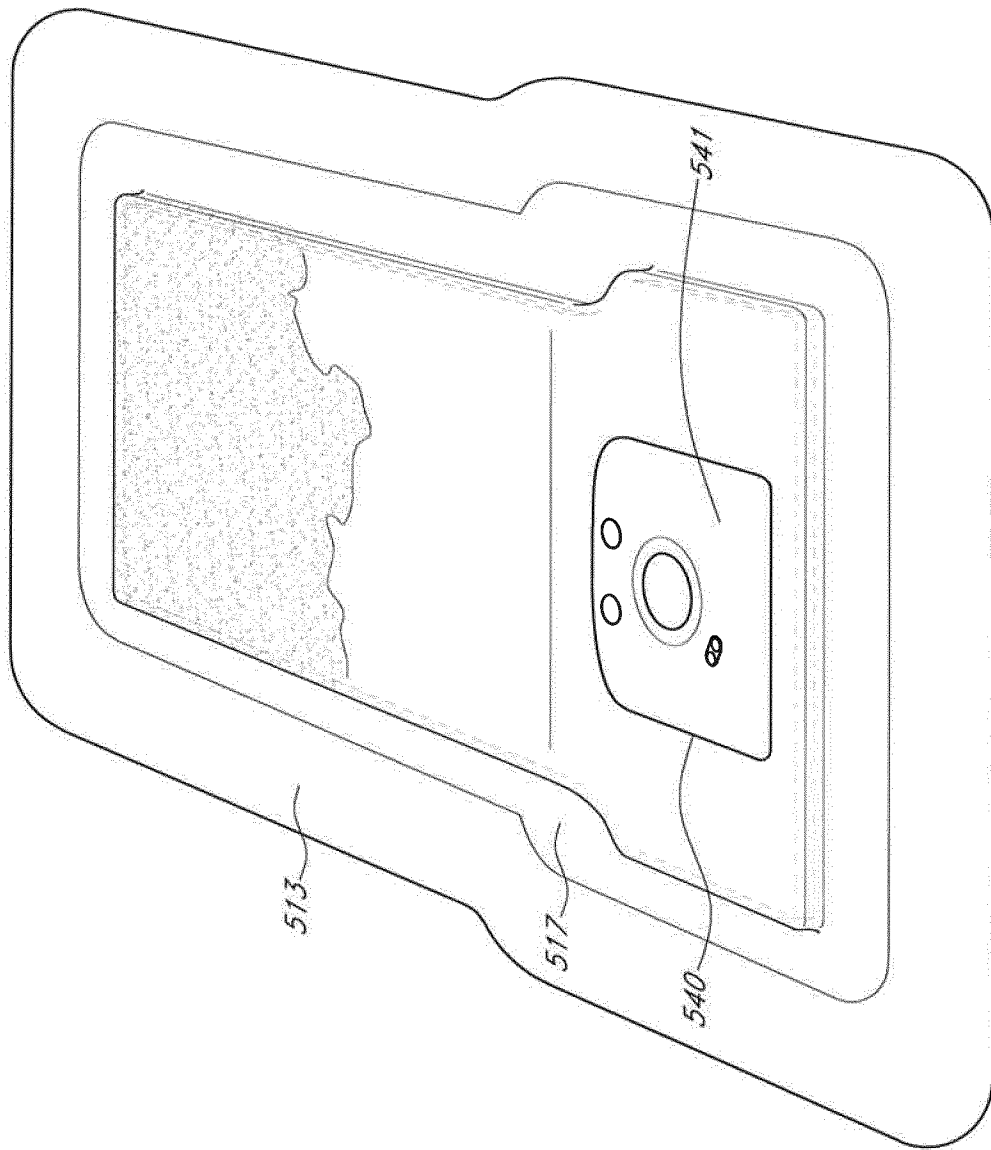

FIG. 5B

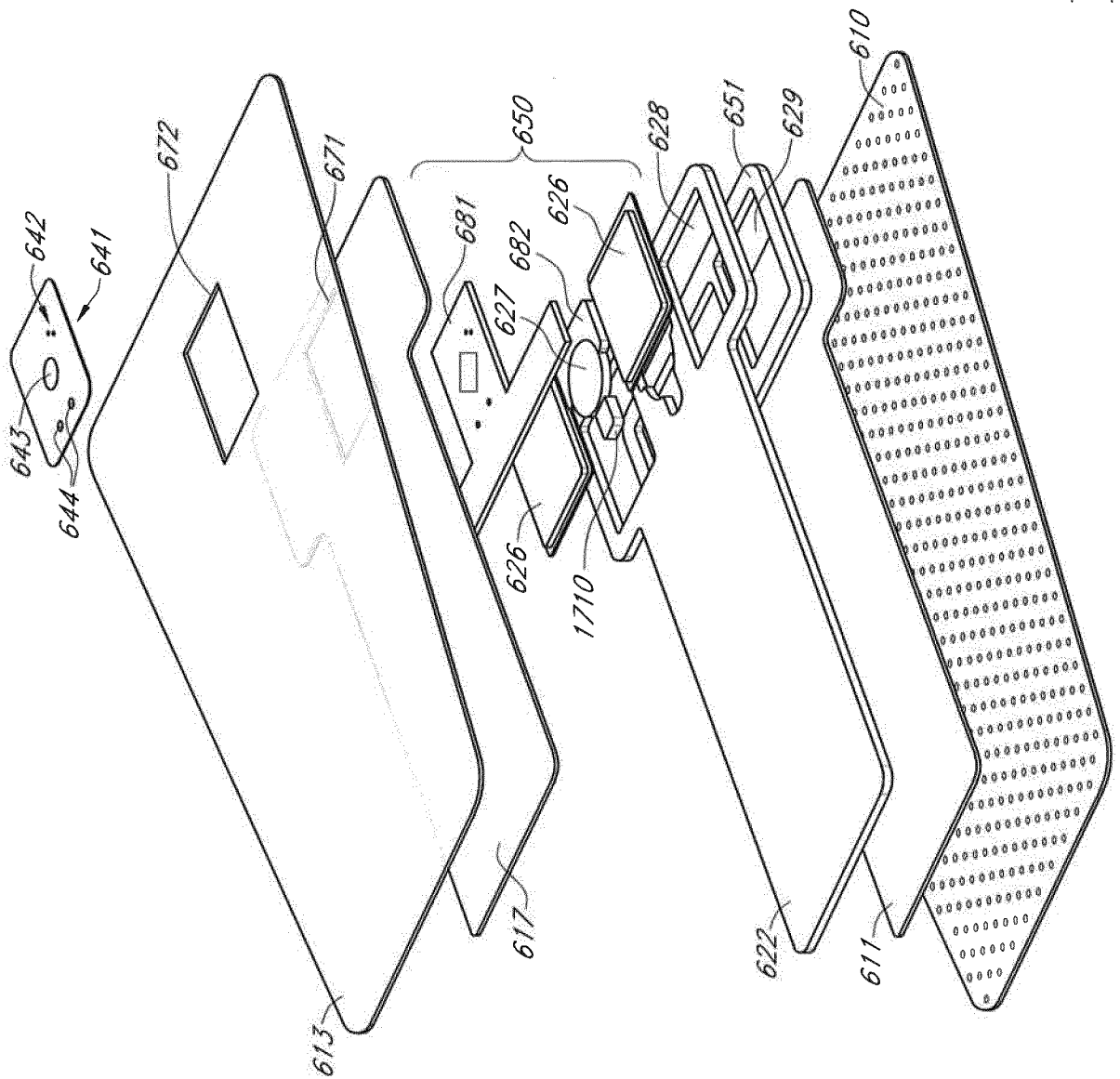

FIG. 6

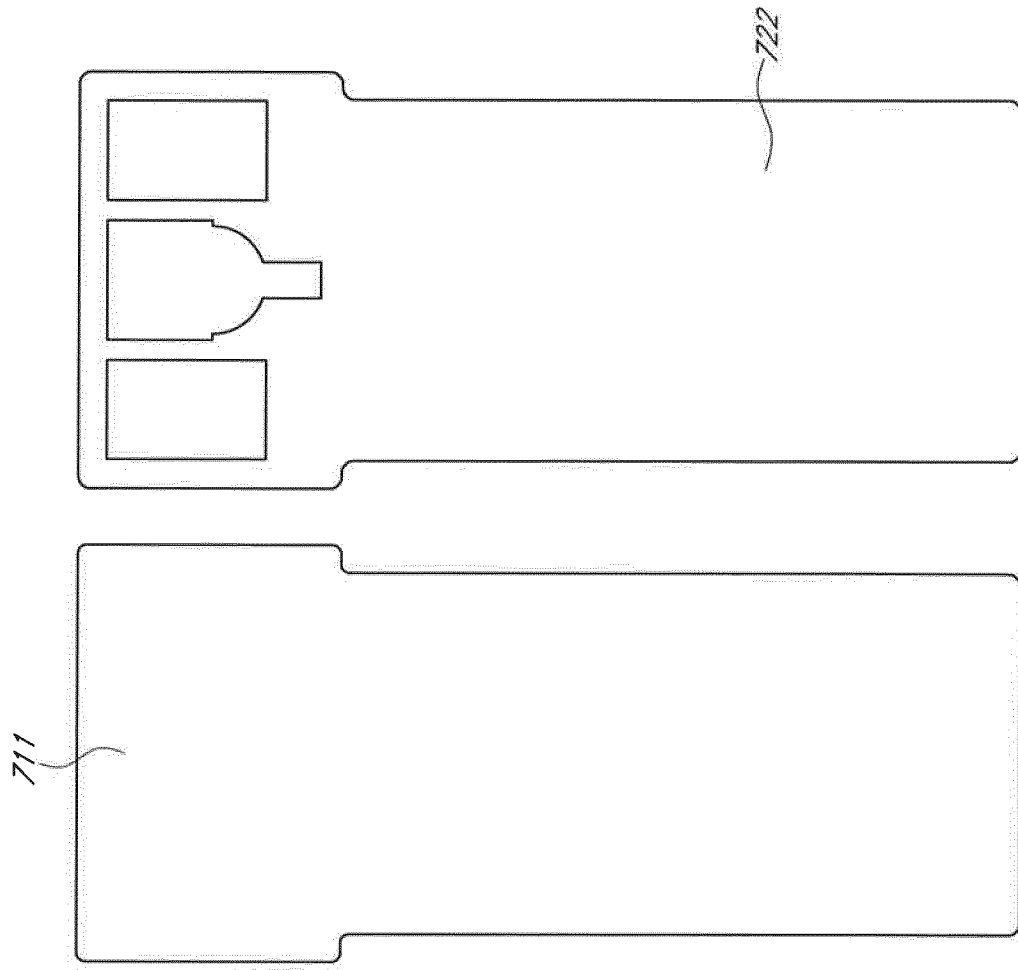

FIG. 7B

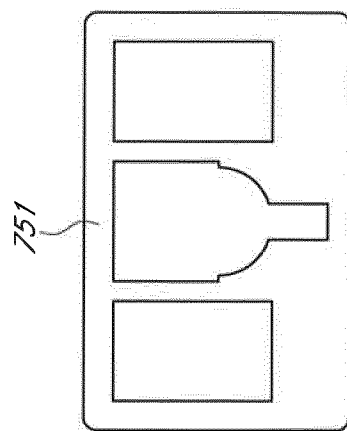

FIG. 7A

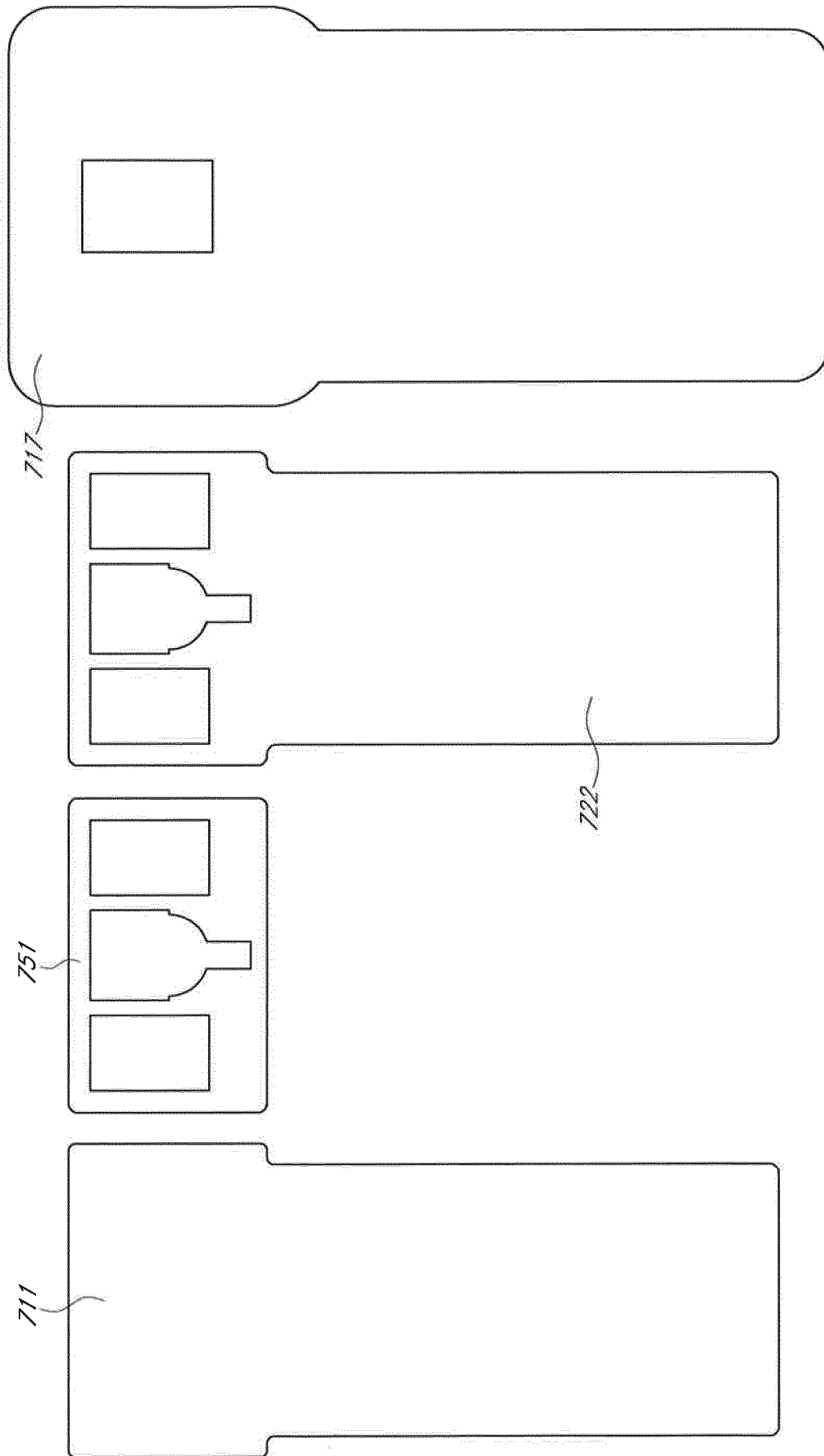

FIG. 7C

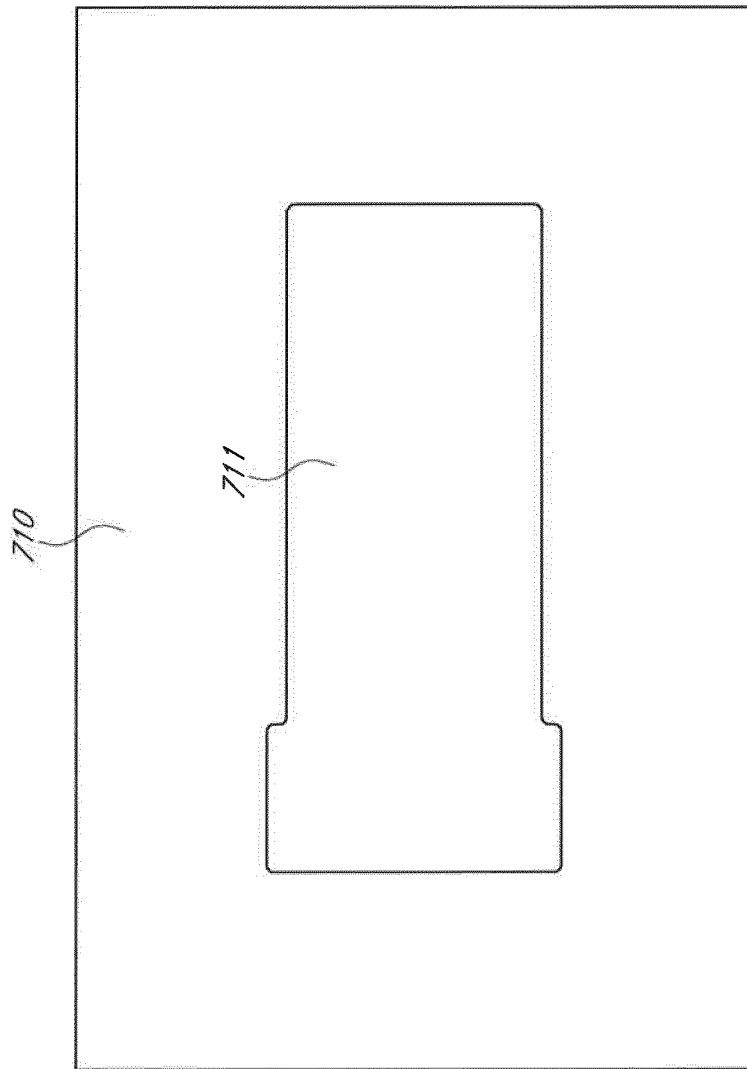

FIG. 8A

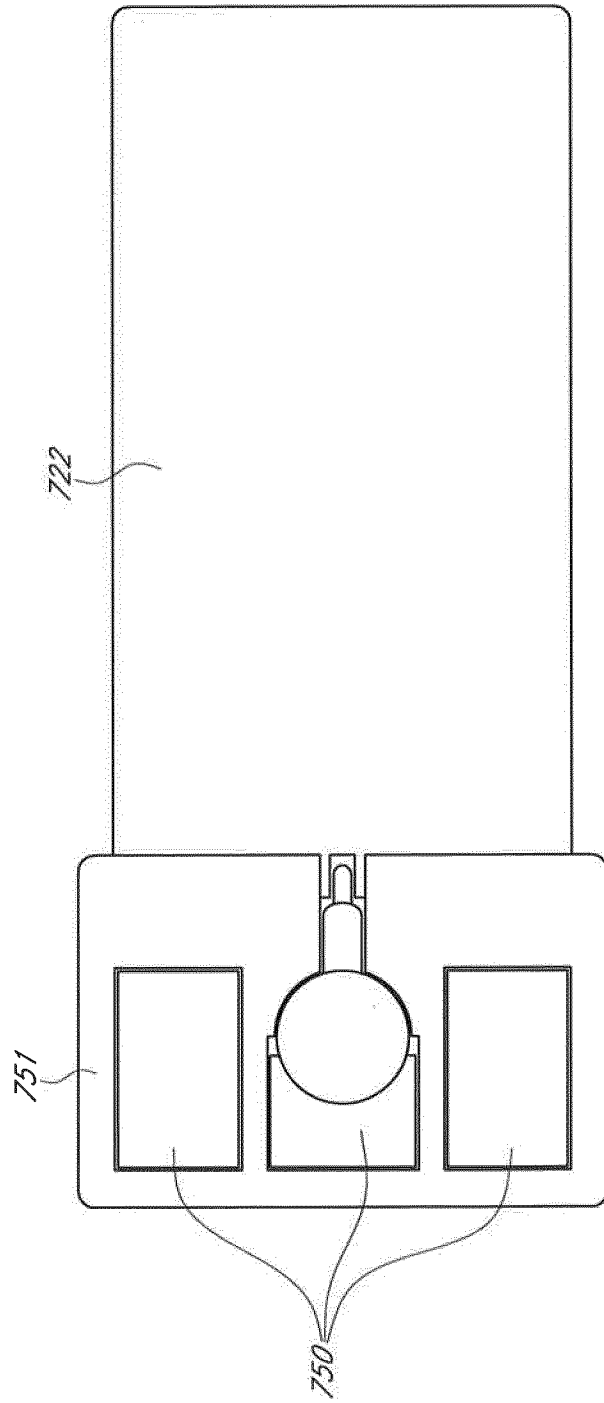

FIG. 8B

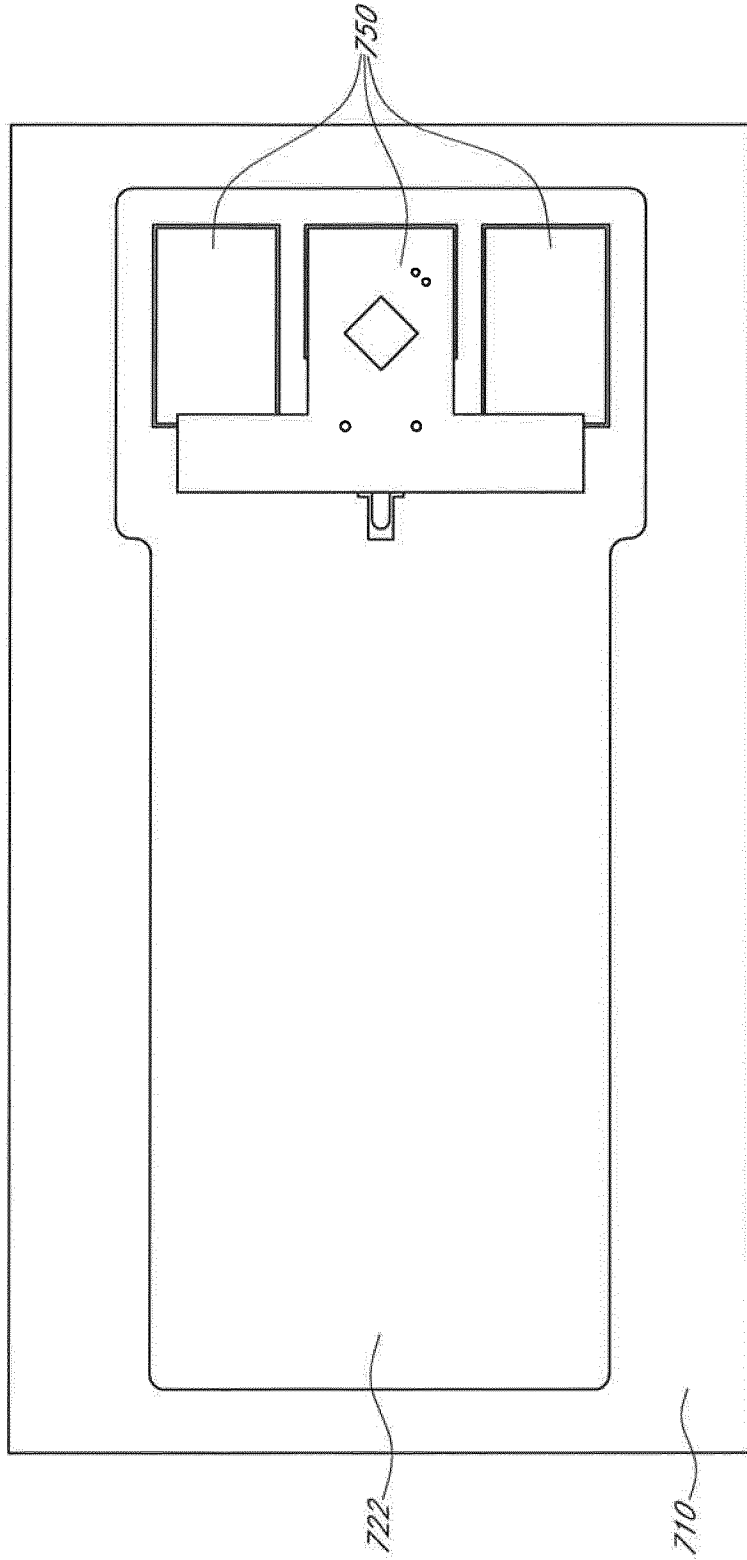

FIG. 8C

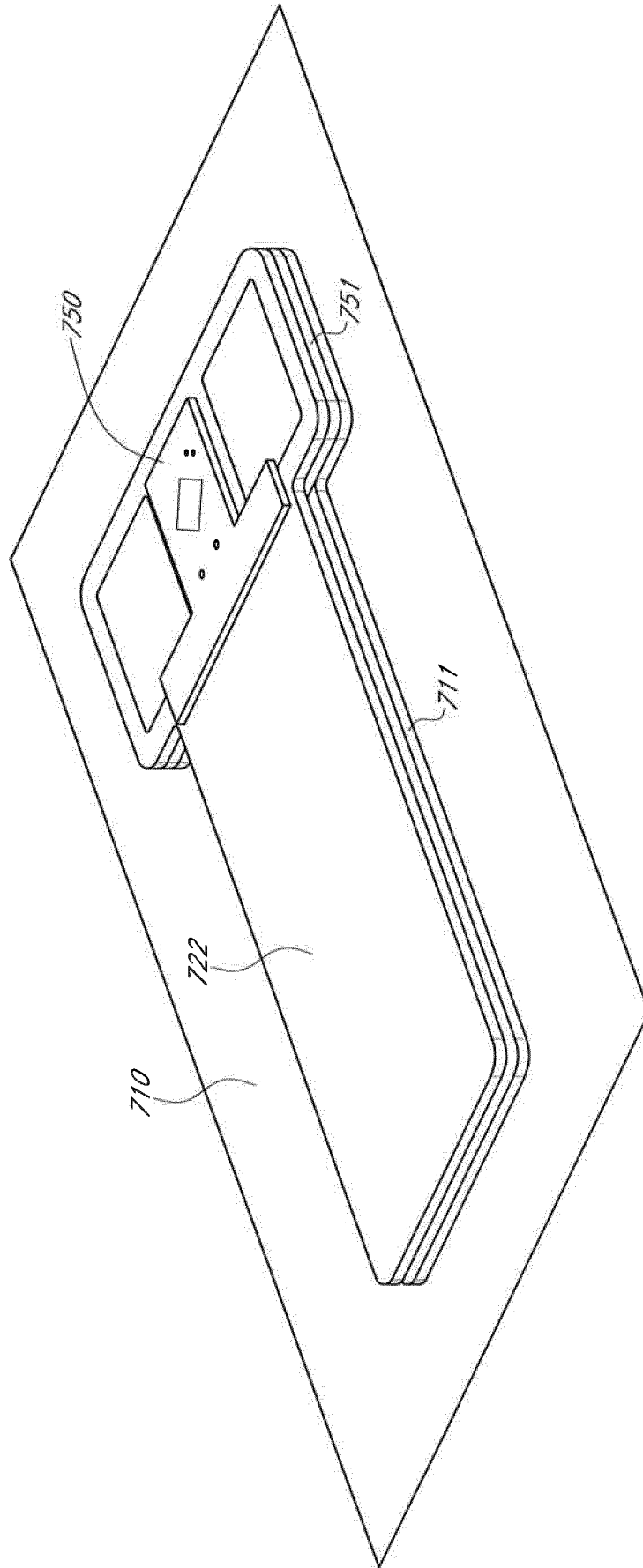

FIG. 8D

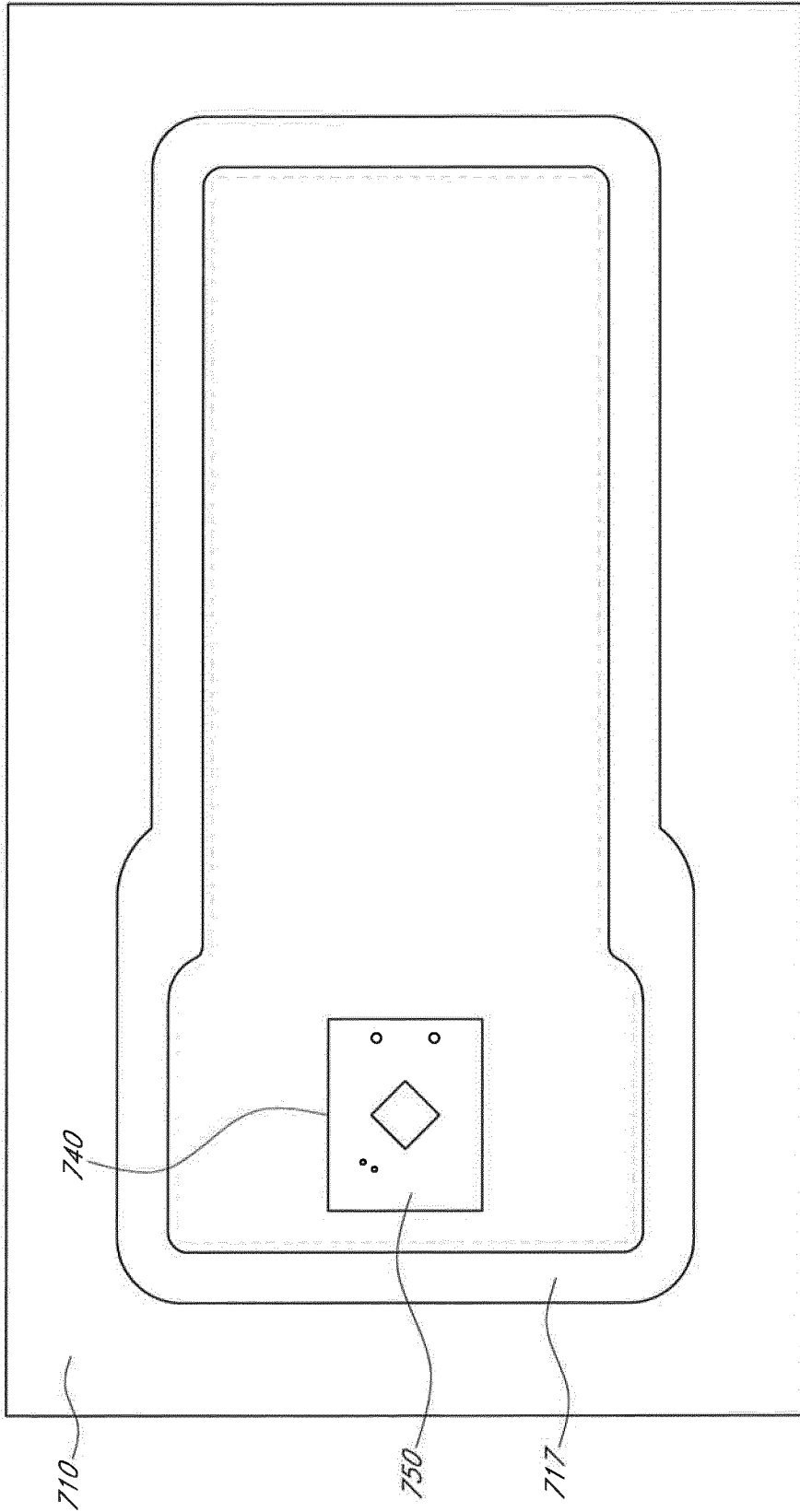

FIG. 8E

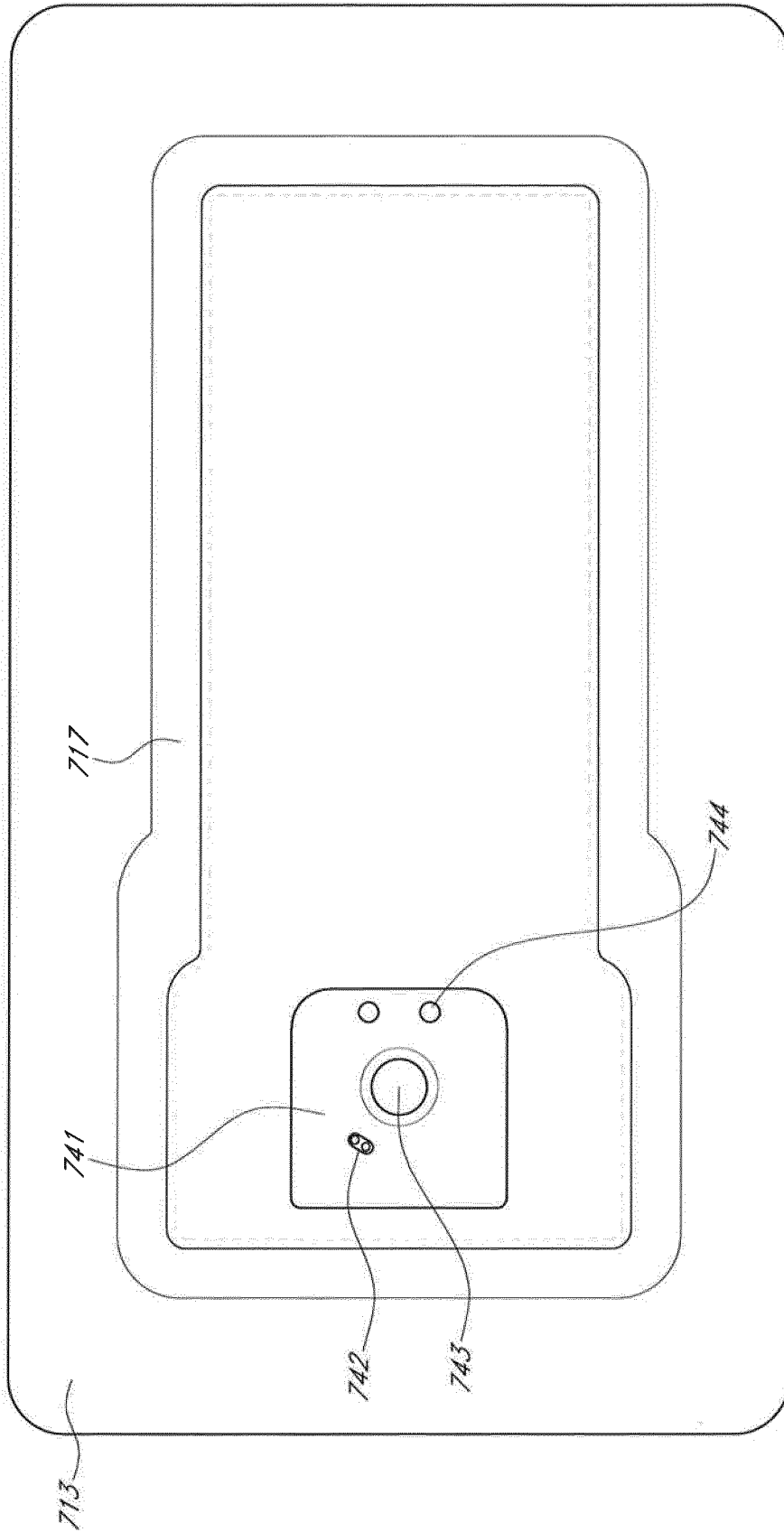

FIG. 8F

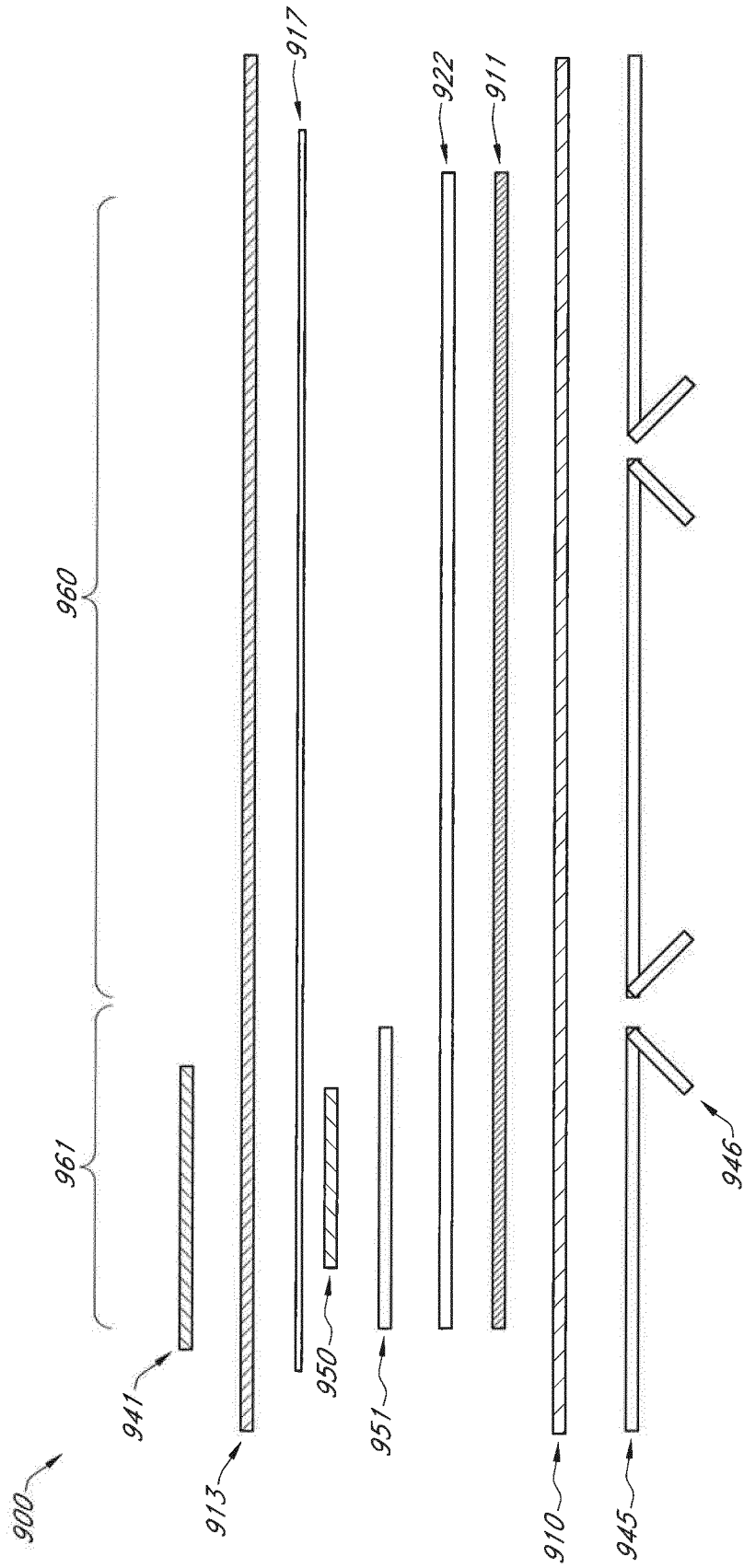

FIG. 9

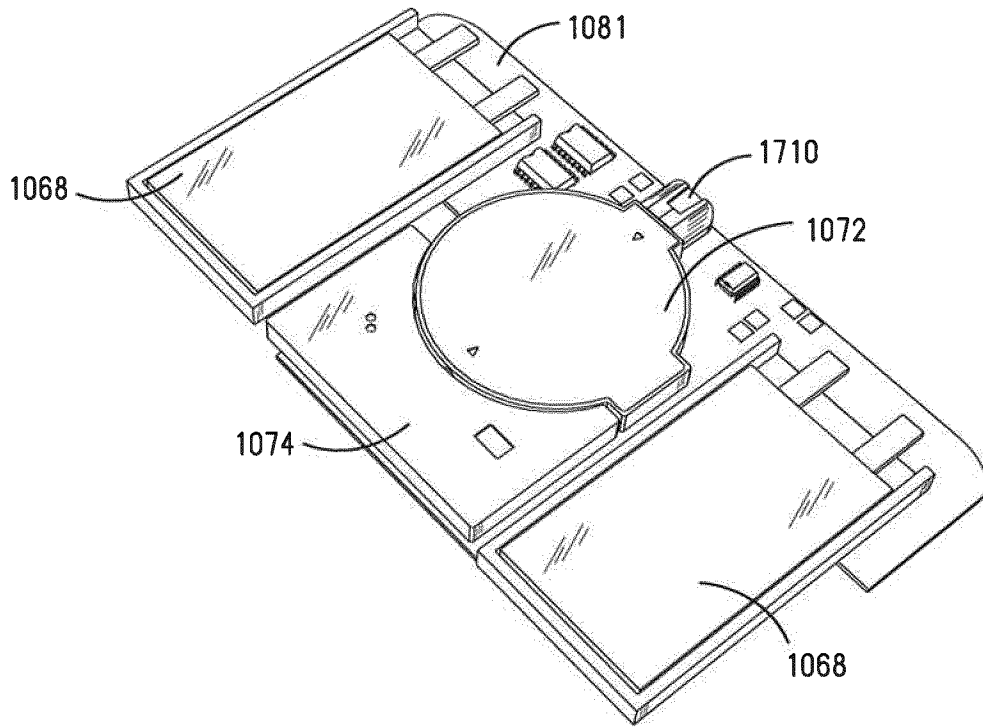

FIG. 10A

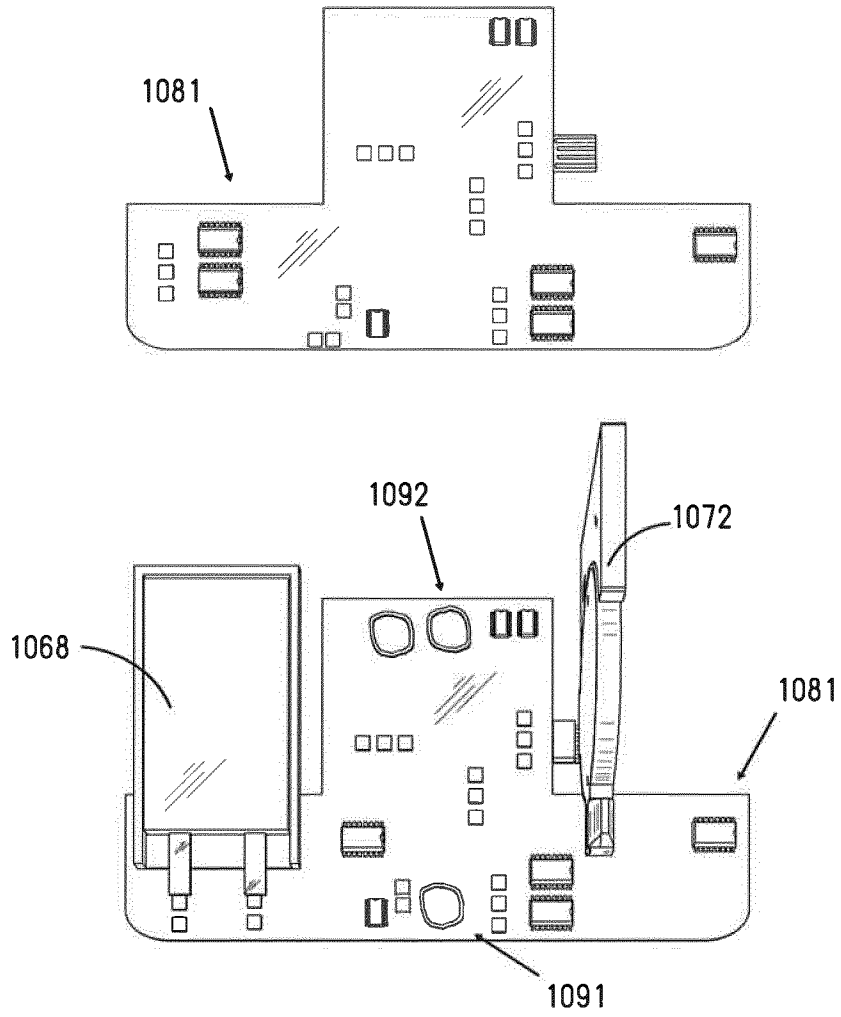

FIG. 10B

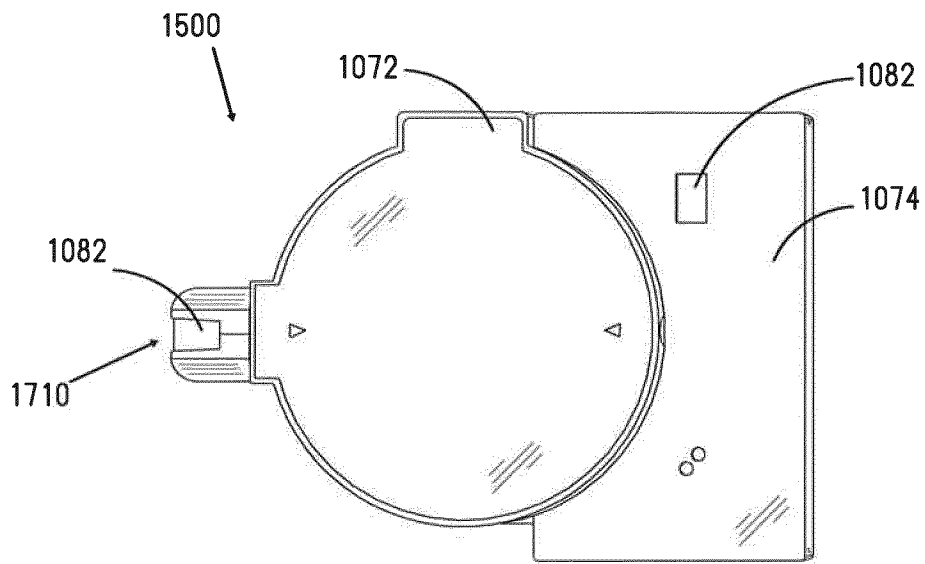

FIG. 10C

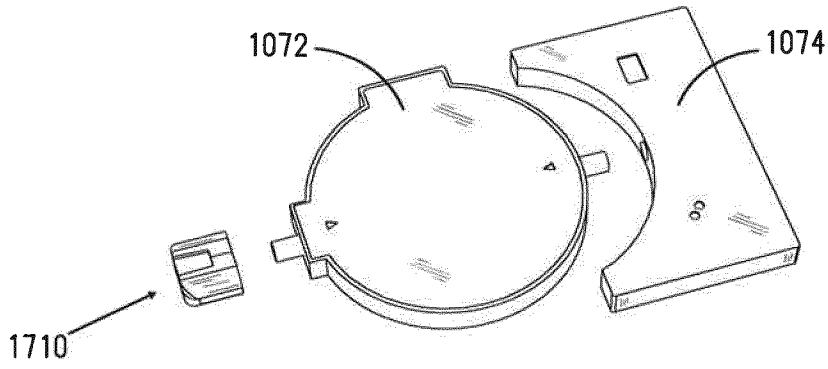

FIG. 11A

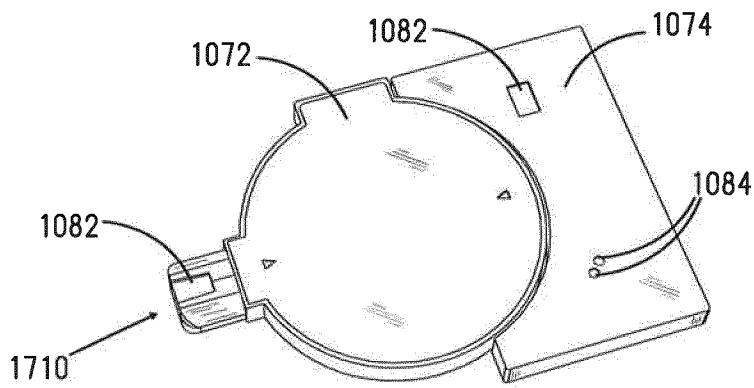

FIG. 11B

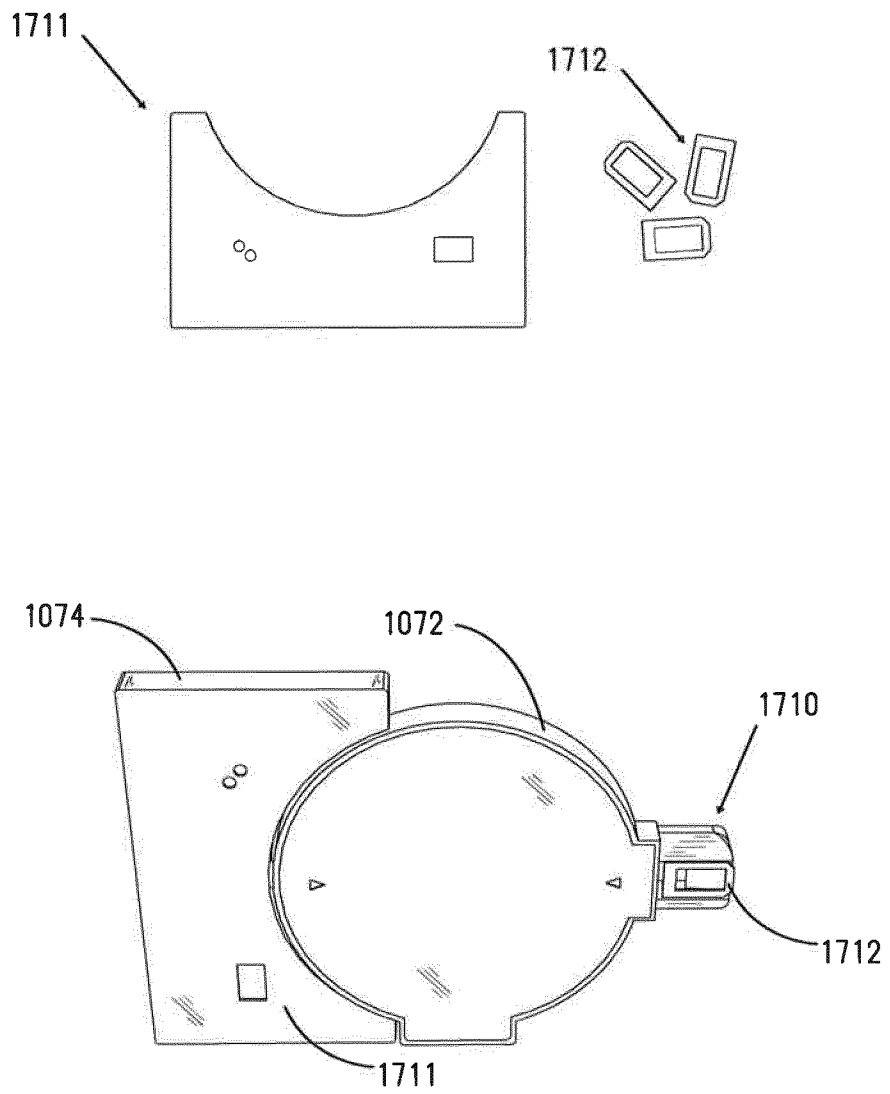

FIG. 12

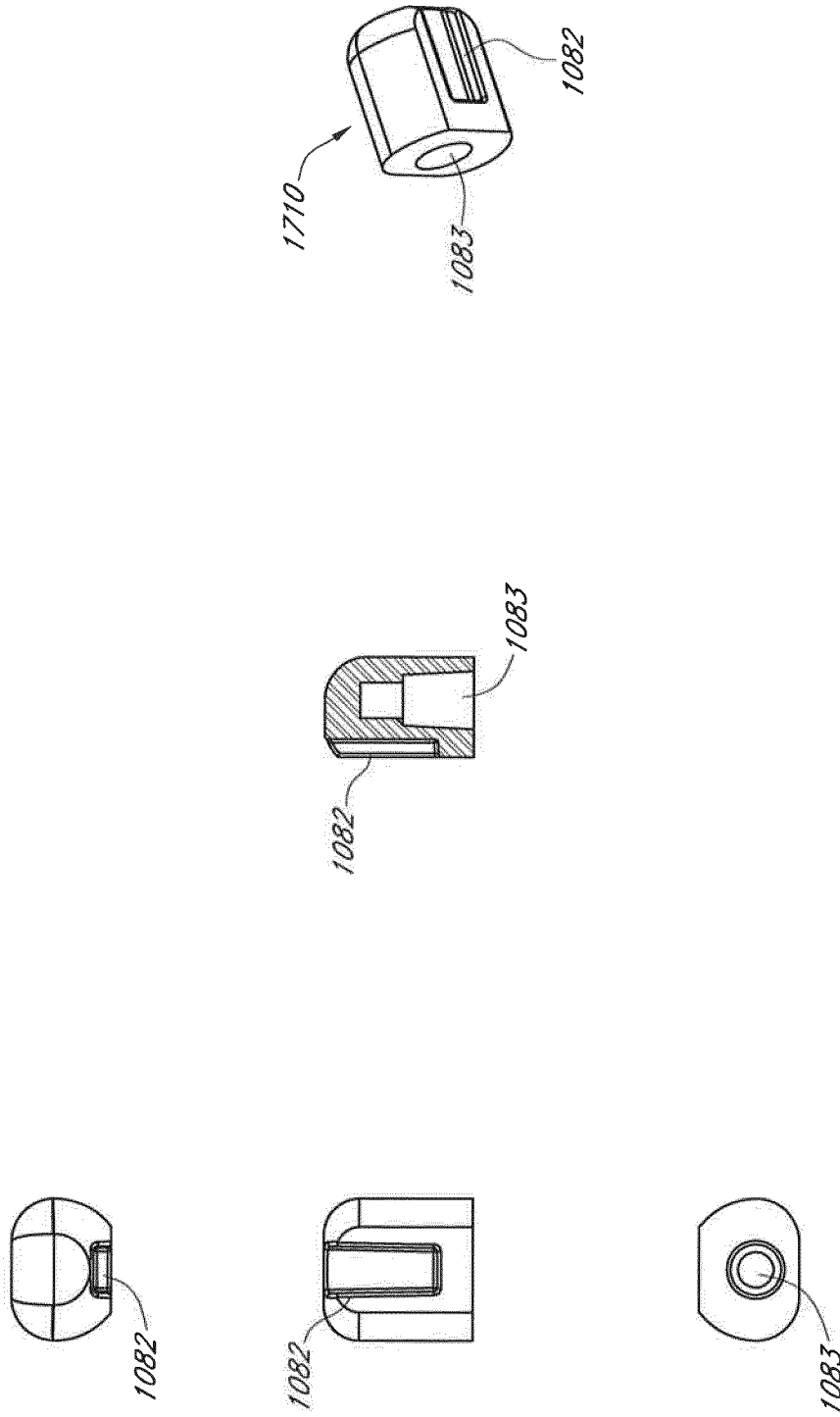

FIG. 13

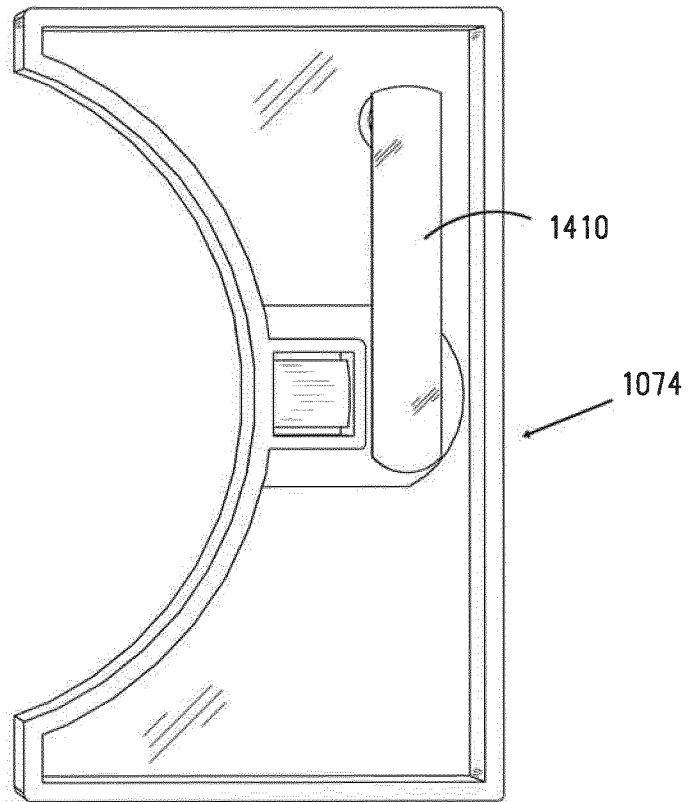

FIG. 14