

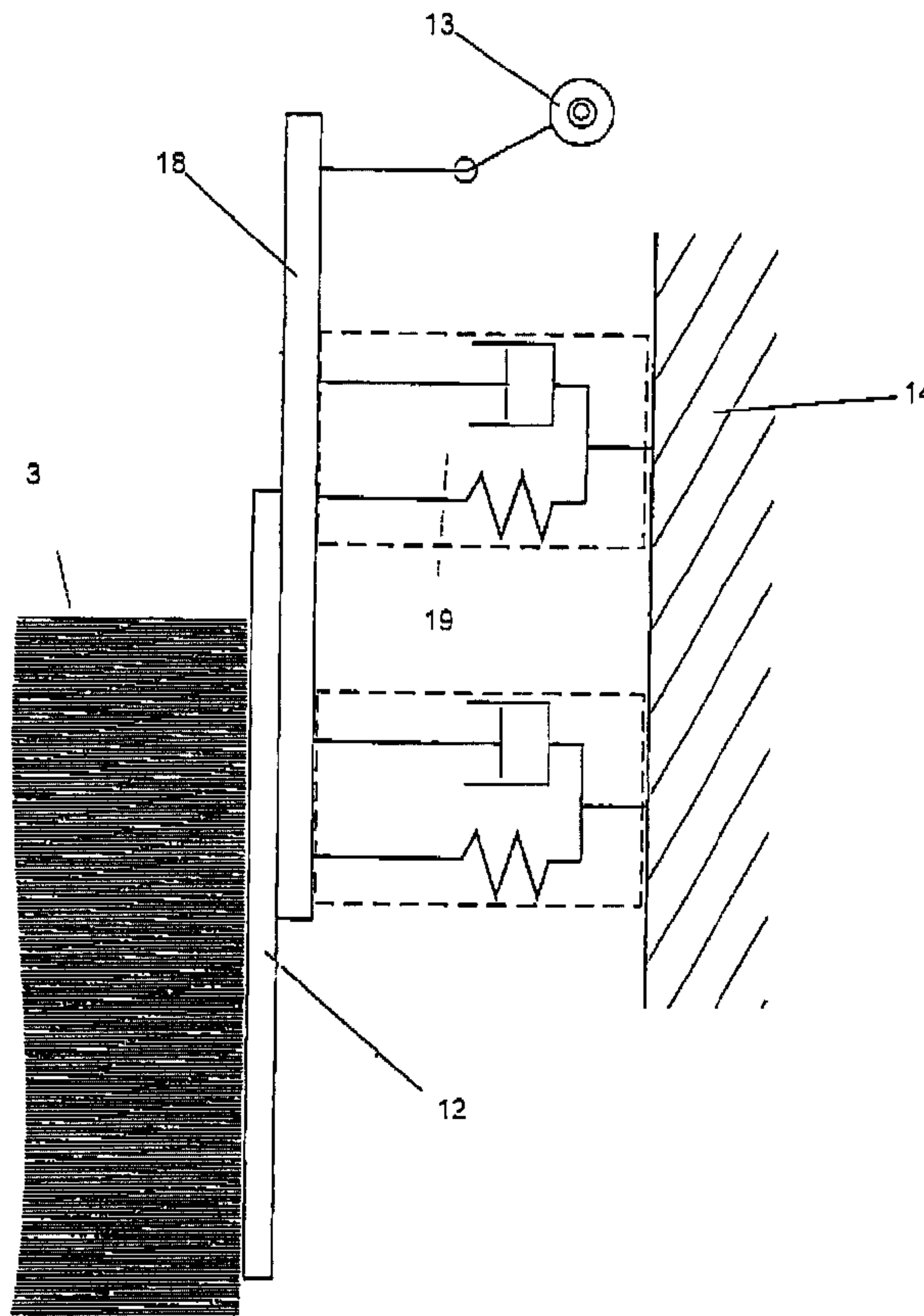

(86) Date de dépôt PCT/PCT Filing Date: 2002/06/19  
 (87) Date publication PCT/PCT Publication Date: 2003/01/30  
 (45) Date de délivrance/Issue Date: 2010/08/31  
 (85) Entrée phase nationale/National Entry: 2004/05/12  
 (86) N° demande PCT/PCT Application No.: EP 2002/006762  
 (87) N° publication PCT/PCT Publication No.: 2003/008313  
 (30) Priorité/Priority: 2001/07/19 (DE101 34 425.2)

(51) Cl.Int./Int.Cl. *B65H 31/38* (2006.01)  
 (72) Inventeur/Inventor:  
 STITZ, ALBERT, DE  
 (73) Propriétaire/Owner:  
 BIELOMATIK JAGENBERG GMBH + CO. KG, DE  
 (74) Agent: BATTISON WILLIAMS DUPUIS

(54) Titre : DISPOSITIF D'EMPILAGE DE FEUILLES, EN PARTICULIER DE FEUILLES DE PAPIER OU DE CARTON, TRANSPORTÉES PAR MARGEUR A NAPPE, SUR DES PALETTES  
 (54) Title: DEVICE FOR STACKING SHEETS, ESPECIALLY SHEETS OF PAPER OR CARDBOARD TRANSPORTED BY A STREAM FEEDER, ONTO PALLETS



(57) Abrégé/Abstract:

In order to stack sheets of paper or cardboard (1) transported by a stream feeder onto pallets (4), devices are known which comprise a stacking platform (5) which can be raised and lowered, and on which the piles (3) are formed. During the stacking

(57) **Abrégé(suite)/Abstract(continued):**

process, the longitudinal edge of a sheet (1) is guided by a separating plate (12) which is suspended on a holding element fixed in the machine frame, and is connected to a vibrator (13) in the form of a shaking element. According to the invention, in order to improve the shaking effect of the separating plate (12), a holding plate (18) is fixed, by means of rubber elements (19), to the holding element fixed in the machine frame, in such a way that it is decoupled from vibrations, the separating plate (12) and vibrator (13) being suspended from the holding plate in a rigid manner.

## (12) NACH DEM VERTRAG ÜBER DIE INTERNATIONALE ZUSAMMENARBEIT AUF DEM GEBIET DES PATENTWESENS (PCT) VERÖFFENTLICHTE INTERNATIONALE ANMELDUNG

(19) Weltorganisation für geistiges Eigentum  
Internationales Büro(43) Internationales Veröffentlichungsdatum  
30. Januar 2003 (30.01.2003)

PCT

(10) Internationale Veröffentlichungsnummer  
**WO 03/008313 A1**

- (51) Internationale Patentklassifikation<sup>7</sup>: **B65H 31/38** (71) Anmelder (für alle Bestimmungsstaaten mit Ausnahme von US): **JAGENBERG QUERSCHNEIDER GMBH** [DE/DE]; Jagenbergstrasse 1, 41468 Neuss (DE).
- (21) Internationales Aktenzeichen: PCT/EP02/06762
- (22) Internationales Anmeldedatum: 19. Juni 2002 (19.06.2002) (72) Erfinder; und (75) Erfinder/Anmelder (nur für US): **STITZ, Albert** [DE/DE]; Eichen 3, 51515 Kürten (DE).
- (25) Einreichungssprache: Deutsch
- (26) Veröffentlichungssprache: Deutsch (74) Anwalt: **JOSTARNDT - THUL**; Brüsseler Ring 51, 52074 Aachen (DE).
- (30) Angaben zur Priorität: 101 34 425.2 19. Juli 2001 (19.07.2001) DE (81) Bestimmungsstaaten (national): CA, JP, US.

[Fortsetzung auf der nächsten Seite]

(54) Title: DEVICE FOR STACKING SHEETS, ESPECIALLY SHEETS OF PAPER OR CARDBOARD TRANSPORTED BY A STREAM FEEDER, ONTO PALLETS

(54) Bezeichnung: VORRICHTUNG ZUM STAPELN VON BÖGEN, INSBESONDERE VON GESCHUPPT ZUGEFÖRDERTEN PAPIER- ODER KARTONBÖGEN AUF PALETTEN

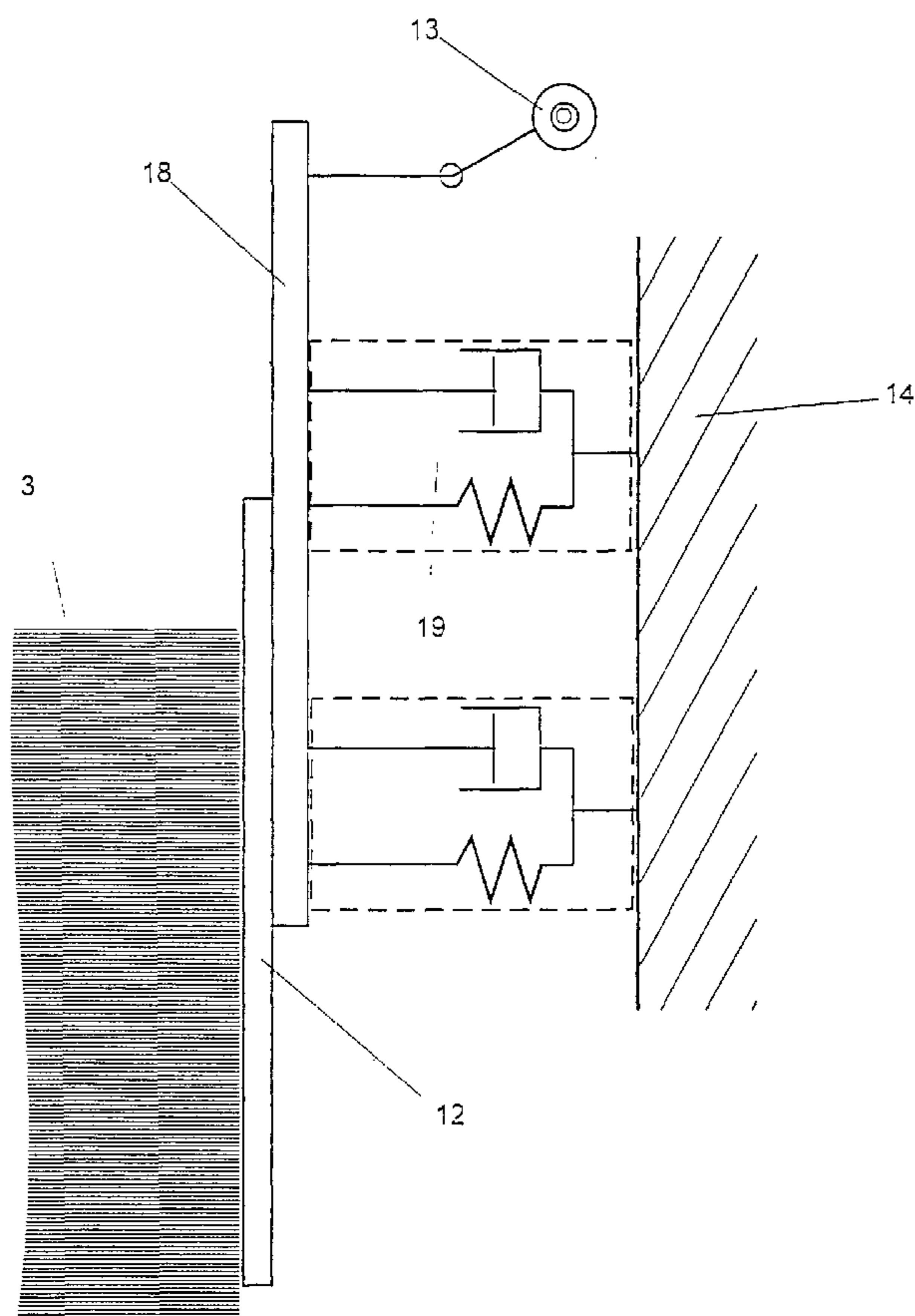

(57) Abstract: In order to stack sheets of paper or cardboard (1) transported by a stream feeder onto pallets (4), devices are known which comprise a stacking platform (5) which can be raised and lowered, and on which the piles (3) are formed. During the stacking process, the longitudinal edge of a sheet (1) is guided by a separating plate (12) which is suspended on a holding element fixed in the machine frame, and is connected to a vibrator (13) in the form of a shaking element. According to the invention, in order to improve the shaking effect of the separating plate (12), a holding plate (18) is fixed, by means of rubber elements (19), to the holding element fixed in the machine frame, in such a way that it is decoupled from vibrations, the separating plate (12) and vibrator (13) being suspended from the holding plate in a rigid manner.

(57) Zusammenfassung: Zum Stapeln von geschuppt zugeführten Papier- oder Kartonbögen (1) auf Paletten (4) sind Vorrichtungen bekannt, die eine heb- und senkbare Ablageplattform (5) aufweisen, auf der die Stapel (3) gebildet werden. Die Längskante eines Bogens (1) wird beim Stapeln von einem Trennblech (12) geführt, das an einem im Maschinengestell befestigten Halter aufgehängt und mit einem Vibrator (13) als Schüttel-element verbunden ist. Um die Schüttelwirkung eines Trennblechs (12) zu verbessern, ist nach der Erfindung an dem im Maschinengestell befestigten Halter eine Halteplatte (18) über Gummielemente (19) schwingungskoppelt befestigt, an der das Trennblech (12) und ein Vibrator (13) starr aufgehängt sind.

WO 03/008313 A1

**WO 03/008313 A1**



**(84) Bestimmungsstaaten (regional):** europäisches Patent (AT, BE, CH, CY, DE, DK, ES, FI, FR, GB, GR, IE, IT, LU, MC, NL, PT, SE, TR).

*Zur Erklärung der Zweibuchstaben-Codes und der anderen Abkürzungen wird auf die Erklärungen ("Guidance Notes on Codes and Abbreviations") am Anfang jeder regulären Ausgabe der PCT-Gazette verwiesen.*

**Veröffentlicht:**

— mit internationalem Recherchenbericht

## DESCRIPTION

### **Device for stacking sheets, especially sheets of paper or cardboard transported by a stream feeder, onto pallets**

#### **Technical field**

The invention relates to a device for stacking sheets, especially sheets of paper or cardboard transported by a stream feeder, onto pallets, with a stacking platform that can be raised or lowered on which the stacks are formed, and with at least one separating plate that guides the longitudinal edge of a sheet during the stacking, that is suspended on a holder attached to the machine frame and with a vibrator as a shaking element.

#### **State of the art**

In order to stack sheets coming from a crosscutting machine, it is a known procedure to employ devices having a stacking platform that can be raised or lowered onto which the pallets for receiving the stacks have been placed. In the stacking station, there are stack-forming elements that ensure trouble-free stacking of the sheets with precisely aligned edges. Such stacking mechanisms are in the form of a stop plate for the leading edges of the sheets and in the form of separating plates that stand upright and extend in the sheet-travel direction while they guide the longitudinal edges of the sheets during the stacking operation. The separating plates can be adjusted crosswise to the two longitudinal sides of the stacking device and, in the case of a multiple-line stacking operation, are also arranged between two stacks that are being formed next to each other. They are made to vibrate by means of vibrators so that the stack section being formed is aligned with pre-

cise edges. Such stacking devices are described in German patent DE 44 38 964 and in world patent WO 00/20315.

German patent application DE 29 42 855 A1 discloses a stacking device for a printing machine that has vibrating means, each with a linear vibrator, arranged at the vertical sides of the paper stack. Each vibrator is elastically suspended by means of a holding plate, a rubber block and a holding brace on a stationary frame part of the stacking device. Its armature shaft is connected to the vibrating plate.

Another stacking device with vibrating means is described in German patent DE 42 21 660 C2. With this device, a stop plate consisting of two parts is vibrated, whose front part is attached to the back part via elastic rubber damping elements. The vibrating means is attached to the front part as well as to the back part of the stop plate.

### **Description of the invention**

The invention is based on the objective of improving the vibrating effect of the separating plates in a device of the generic type.

This objective is achieved in that, on the holder attached to the machine frame, there is a holding plate attached via rubber elements so as to be vibration-uncoupled and on which the separating plate and a vibrator are rigidly suspended.

This construction has the advantage that, during the vibration, the vibrator itself can only rest on the stack so that the entire vibration energy is transmitted to the stack. This greatly increases the effect of the vibrator.

Another advantage is that the vibrator does not impart vibrations to any other parts of the stacking device. Thus, the rest of the suspension of the separating plate is less stressed.

The subclaims contain embodiments of a device according to the invention that are preferred since they are especially advantageous:

- 5 The separating plate may be detachably attached to the holding plate. Consequently, it can be replaced without disassembling the vibrator.

In some embodiments, the holder may have as a holding plate that can be raised and lowered makes it possible to raise the separating plate with the vibrator into an inactive position above  
10 the stack when it is not needed.

In other embodiments, an ejection roll and a separating shoe are attached to the holding plate so that all of the stack-forming elements that act on a longitudinal edge of the sheet can be raised and lowered with one single shared lifting drive.

15

According to an aspect of the invention, there is provided an apparatus for stacking sheets (1) in particular paper or cardboard sheets (1) fed in imbricated form, on pallets (4), having a set-down platform (5) which can be raised and lowered and on which the stacks (3) are formed, and having at least one separating plate (12) which guides the longitudinal edge of the sheet (1)  
20 during stacking, is suspended on a holder fastened in the machine framework and is connected to a vibrator (13) as shaking elements, characterized in that a retaining plate (18) is fastened for vibration isolation, via damping-action rubber elements (19) on the holder, which is fastened in the machine framework, and the separating plate (12) and a vibrator (13) are suspended rigidly on this retaining plate.

25

#### **Brief description of the drawings**

The drawing serves to explain the invention with respect to an embodiment depicted in a simplified manner:

- 3a -

Figure 1 – is a schematic representation of the side view of a stacking device.

Figure 2 – is an enlarged representation of the side view of the stack-forming elements acting on the longitudinal edges of the sheet.

5

Figure 3 – is a view of the stack-forming elements opposite from the sheet-travel direction.

Figure 4 – is a schematic view of the suspension of a separating plate with the appertaining vibrator.

#### **Ways to execute the invention**

The stacking device shown in the figures serves to stack sheets 1 of paper or cardboard that are continuously fed by a stream feeder and that were produced with a crosscutting machine. The sheets 1 are fed to the stacking station by a feed mechanism 2 that is configured as a conveyor belt and that is arranged at a fixed vertical position above the ground at a height above the maximum stack height. The stacks 3 are formed on pallets 4 that lie on a stacking platform 5. The stacking platform 5 is suspended in the frame of the stacking device so that it can be raised up to the area of the feeding level of the sheets 1 and lowered to the floor area.

The frame of the device comprises two inlet-side posts 6 and two outlet-side posts 7 that are arranged outside of the working width on the two longitudinal sides of the machine and that are connected to each other at their upper ends by longitudinal beams 8 and transverse beams. The posts 6, 7 define the limits of the stacking station.

In the area of the feeding level of the sheets 1, there are various elements that serve for a trouble-free feeding of the sheets 1 to the stacking station and for their edge-aligned placement on the stack 3. Up to four stacks 3 are formed next to one another at the same time. Therefore, the crosscutting machine additionally cuts the web of paper or cardboard – from which the sheets 1 are made – into individual webs by making an appropriate number of longitudinal cuts before the crosscutting operation.

As the stack-forming elements, the device comprises a stop plate 9 extending crosswise over the working width of the device, whereby the leading edges of the sheets are aligned against said stop. In order to adjust the position of the stop plate 9 in the

longitudinal direction for different paper lengths, it is suspended so as to be longitudinally slidable at the rear of the stacking station.

Downstream from the feed mechanism 2, crosswise over the working width, there are ejection rolls 10 arranged at a distance from each other, by means of which the sheets 1 are transferred to the stacking station. In the sheet-travel direction, immediately downstream from the ejection rolls 10, there are separating shoes 11 by means of which the longitudinal edges of two adjacent sheets 1 are bent upwards. The curvature of a sheet 1 along its longitudinal edges leads to so-called cupping, which stabilizes the sheet 1 and, at the same time, brings about a reliable separation of two adjacent sheets 1.

Downstream from each separating shoe 11, there is a separating plate 12 that extends upright and in the sheet-travel direction. The separating plates 12 have the function of laterally guiding and aligning the sheets 1 in order to place them with precisely aligned edges on the stack. Therefore, said separating plates are arranged in the stacking station between two stacks 3 and on the two outer longitudinal edges of the outer stack 3. The separating plates 12 are each suspended on a holder attached to the machine frame and connected to a pneumatic or electric motor vibrator 13 that serves as the shaking drive, by means of which they are vibrated at a frequency of several Hertz. The suspension of a separating plate 12 with a vibrator 13 is shown in greater detail in Figures 2 and 3 and is depicted schematically in Figure 4:

A separating plate 12 is suspended together with the ejection rolls 10 and the separating shoe 11 on a holding plate 14 that serves as a holder and that is attached to the end of two guide rails 15. At their upper end, the guide rails 15 are attached to a carriage 16 that is mounted on a crossbar so as to slide crosswise. A piston-cylinder unit 17, likewise attached to the carriage 16 and to the holding plate 14 makes it possible to raise the holding plate 14 with the elements attached thereto out of their working position into an inactive position above the stack 3. The shared suspension of the ejection roll 10, of the separating plate 12 and of the separating shoes 11 has the advantage that these elements

can be adjusted crosswise by one single shared traversing drive and they can be raised and lowered by a shared lifting drive (piston-cylinder unit 17).

Attached to the holding plate 14, there is a second holding plate 18 that is arranged in the front in Figure 2 and to the left of the holding plate 14 in Figure 3. The second holding plate 18 is attached to the holding plate 14 exclusively by means of rubber elements 19 that have a damping effect so that the two holding plates 14, 18 are vibration-uncoupled from each other. As the rubber elements 19, preference is given to the use of so-called metal-rubber elements that are rubber-elastic and that have a damping effect. On the second holding plate 18, the separating plate 12 and the vibrator 13 are attached so as to be suspended rigidly. Due to the vibration-uncoupled attachment of the second holding plate 18 to the first holding plate 14 that serves as a holder, the vibrator 13 cannot cause the first holding plate 14 to vibrate. The ejection rolls 10 are attached via a bearing bracket 20 to this non-vibrating holding plate 14. The separating shoe 11 is connected to the vibrating holding plate 18, so that it is made to vibrate together with the separating plate 12. The vibration of the separating shoes 11 causes the sheets 1 to slide more easily downwards onto the stack 3.

## CLAIMS

1. An apparatus for stacking sheets (1) in particular paper or cardboard sheets (1) fed in imbricated form, on pallets (4),

5 having a set-down platform (5) which can be raised and lowered and on which the stacks (3) are formed, and

having at least one separating plate (12) which guides the longitudinal edge of the sheet (1) during stacking, is suspended on a holder fastened in the machine framework and is connected to a vibrator (13) as shaking elements,

10 characterized in that a retaining plate (18) is fastened for vibration isolation, via damping-action rubber elements (19) on the holder, which is fastened in the machine framework, and the separating plate (12) and a vibrator (13) are suspended rigidly on this retaining plate.

2. The apparatus according to claim 1, characterized in that the separating plate (12) is fastened in a releasable manner on the retaining plate (18).

15 3. The apparatus according to claim 1 or 2, characterized in that the holder is a retaining plate (14) which is mounted for raising and lowering in the machine framework.

4. The apparatus according to claim 3, characterized in that a pushing-out roller (10) and a separating shoe (11) are additionally fastened on the retaining plate (14).



Fig. 2

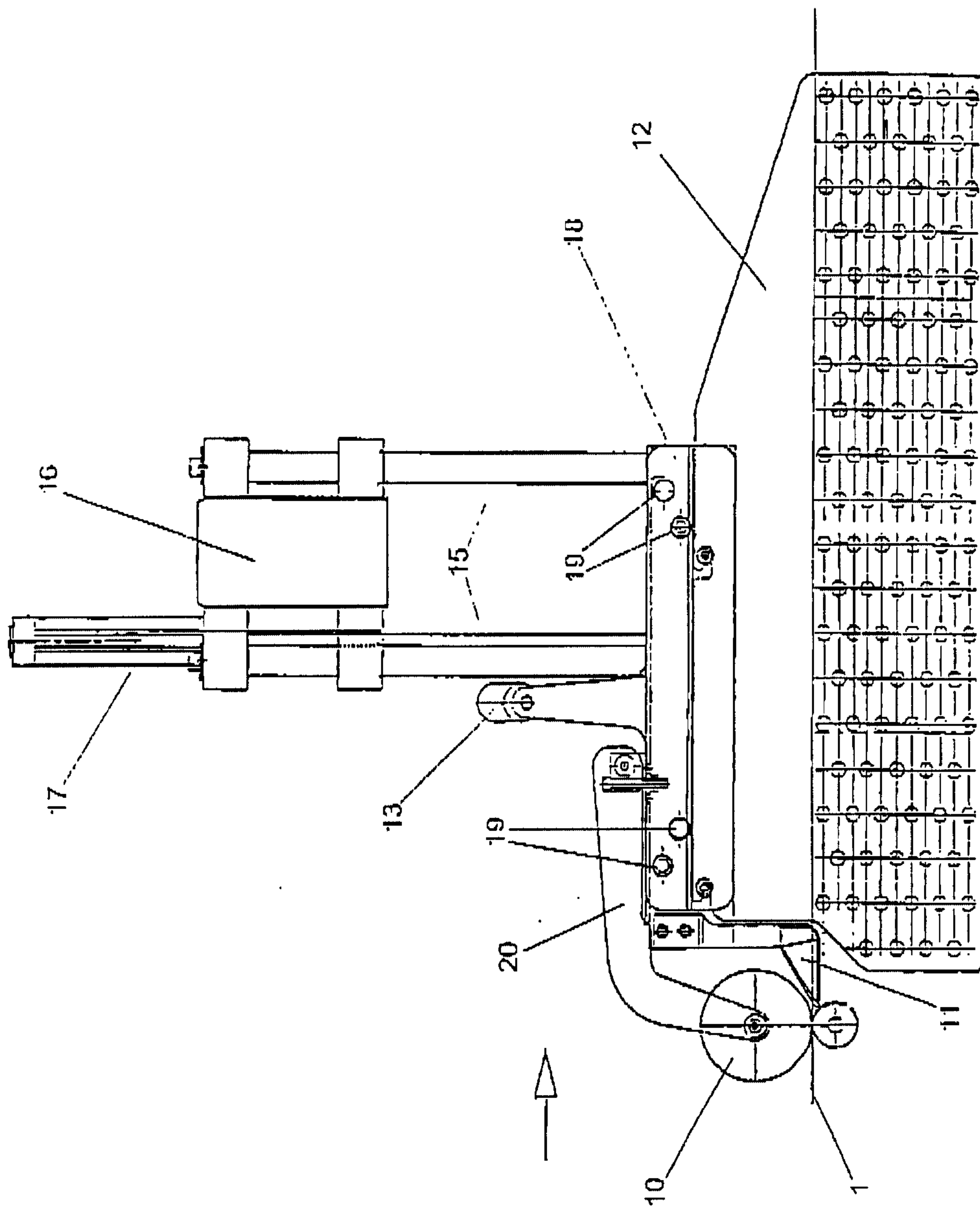

3/4

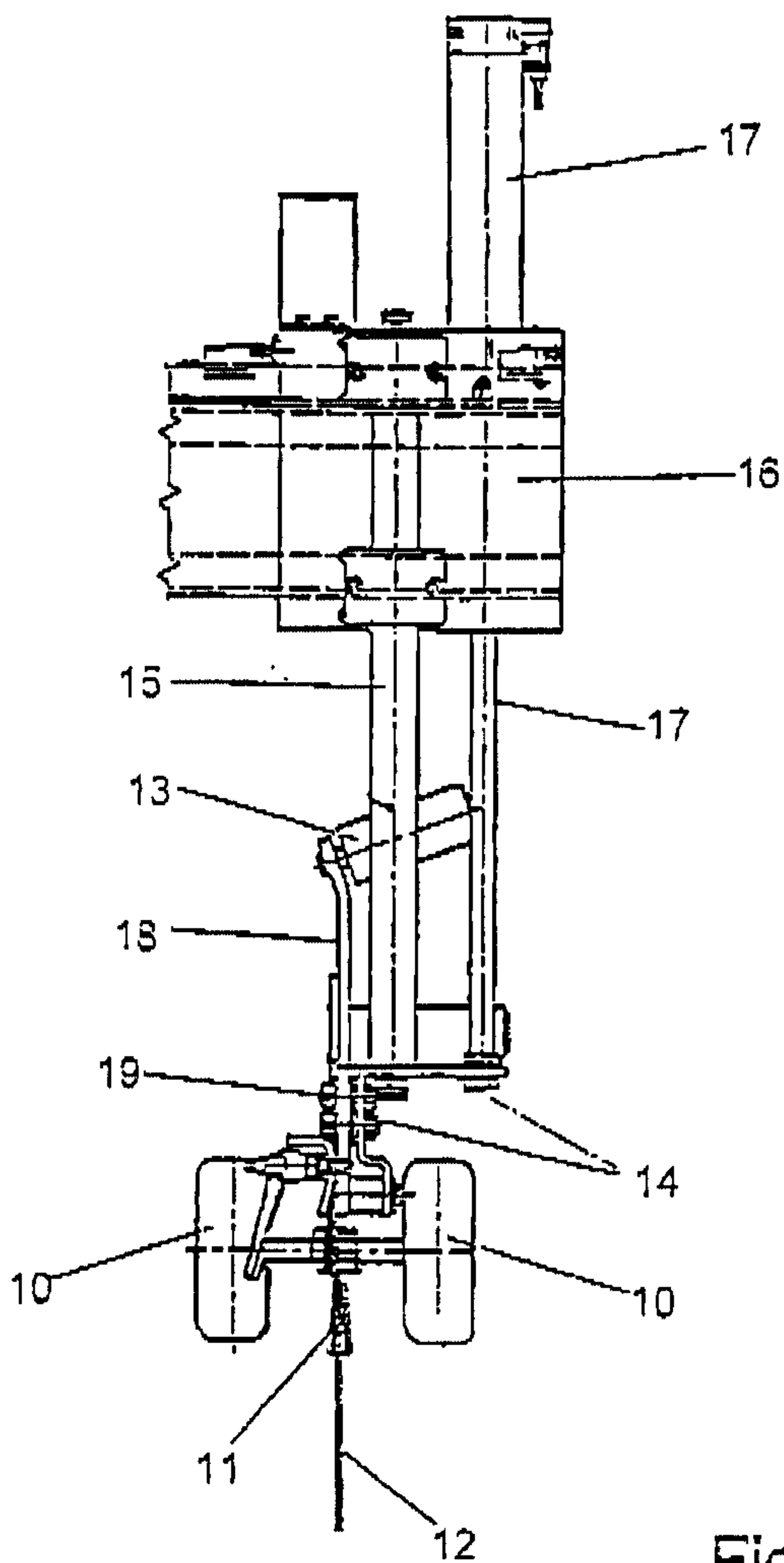

Fig. 3

4/4

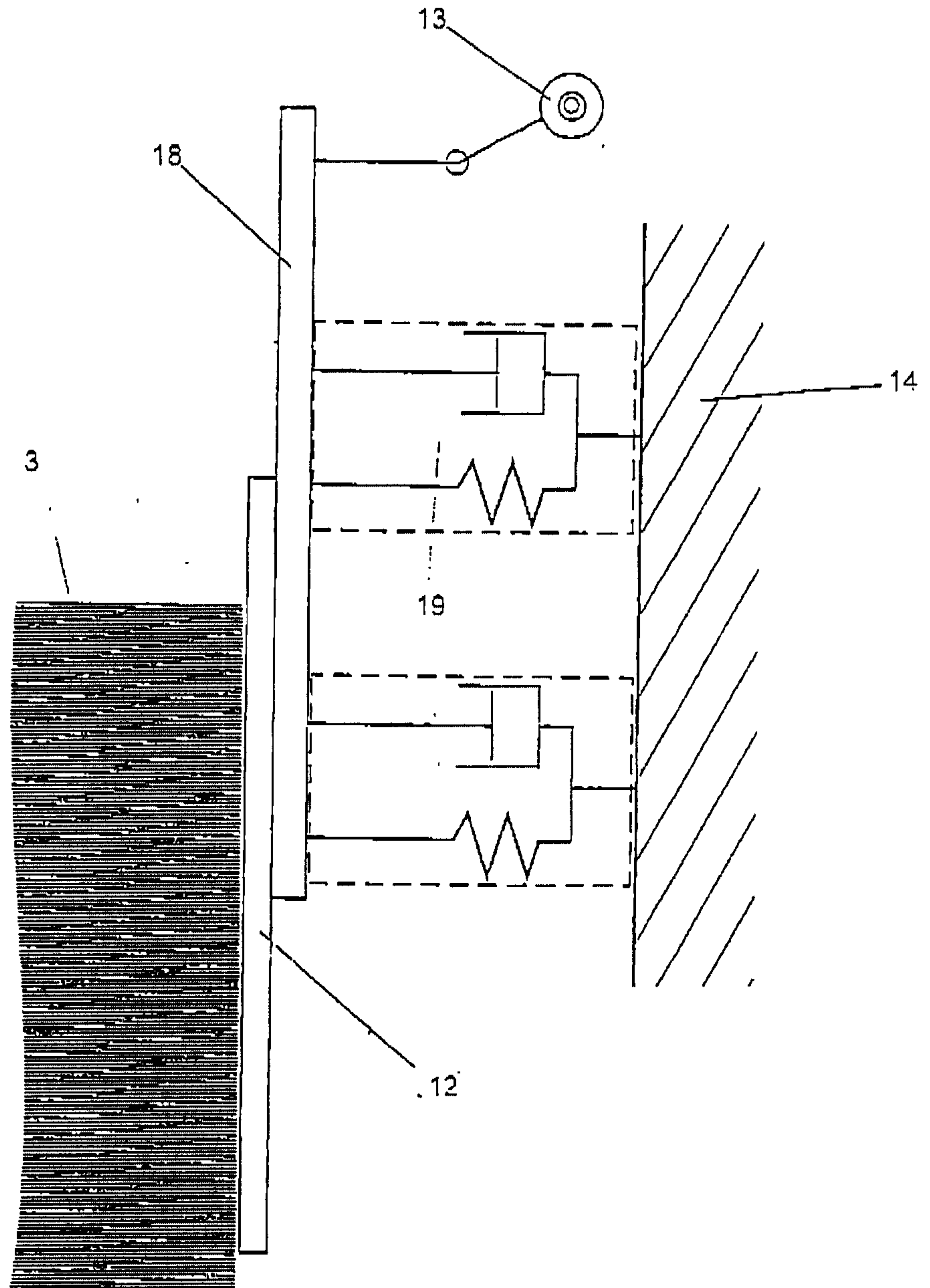

Fig. 4

