

(19)
(12)

(KR)
(A)

(51) 。 Int. Cl. ⁷
B60N 2/46

(11)
(43)

2002 - 0007631
2002 01 29

(21) 10 - 2000 - 0041021
(22) 2000 07 18

(71)

231

(72)

251 1 105 1101

(74)

:

(54)

가	,	가
(120) 가	(102) 가	(110) 가
,	,	,

2

, , ,

1

2

3 2

4 2

5 2 , 가

6 2 ,

* *

102 ; 104 :

110 ; 112 ;

120 ; 122 ;

124 ; 132 ;

133 ; 134 ;

135 ; 136 ;

138 ; 151 ;

152 ; 153 ;

154 ;

가 , 가

, 가 ,

가 .

(arm rest) .

, .

, 가 가

가 1 .

1 (10) (12) (14) , (12) (16)
 (20) (21) (18)가 (1)
 8) (20) (23) (12)가 (12)가 (12)
 가 ()가 .

(14) (12) , (12) (12)
 (14) (12) (19) (12) , (12)

(12) (13)가 , (14)
 4) (13) (15) (13)가 (15) (1)
 (12) (19) (12)

(12) (18) (20) (23) , (12)
 (13) , (20) (21) , 가 (12)
 (13)가 (14) (15) , (14) (19)
 (12) (14)

,
 , 가
 , 가

가

가

가

가 가
 가 가

가

가 .

가 2 6 .

(120) , (110) (102) 가 (110) (110) (130)

(120) (110) (110) (122) (110)
 (124)가 (124) (110) (122)
 (112) (110) (124) (124) (124)가 (110) (112)
 (120) (110) (124)가 (120) 가
 ()가 .

(130) (132), (134), (136), (153) 가 .
 (132) (110) (110) (110)
 (133) (134) (132) (133) (151) (1
 52) (135) , (136) 가 .

4 (132) (133) (134) (135)
 (153) (154)가 .

(104) (102) (138) (134)
 (136) (102) (138) .

142 (132) (110)
 144, 145 (132, 134) (133, 135)
 (133, 135) 가 , 146 147 (110)

가 (130) (102) (104)
 가 (120)

(102) (104) 가 , 5 (130)
 (132) (110) (102) (104)
 (102) (104) (132) (134)
 (153) (154) (132)
 (132, 134) (133, 135) .

(124) , (110) 6 (124) 가 , 가 (120)
 24) , (120) , (110) (112) (122) (1

, 가
 , 가
 가
 , 가

(57)

1.

, ;
 가 가
 ;

2.

1 , 가 ;
 가 가 ;

3.

1 , 가 , 가 ,

1

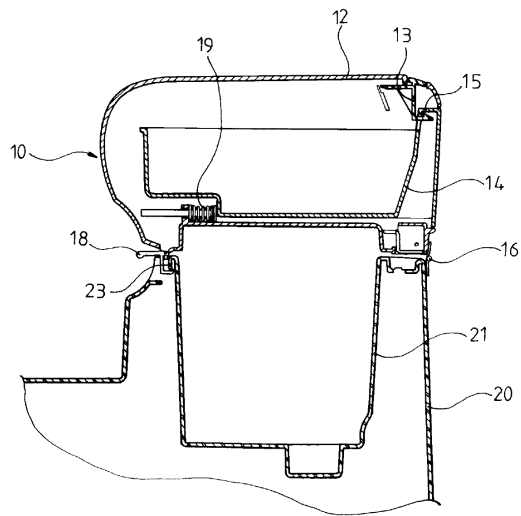

2

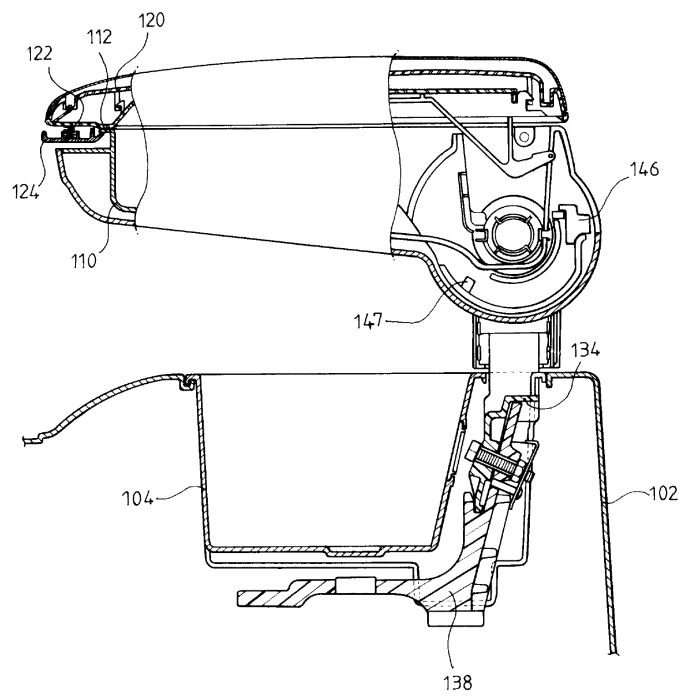

3

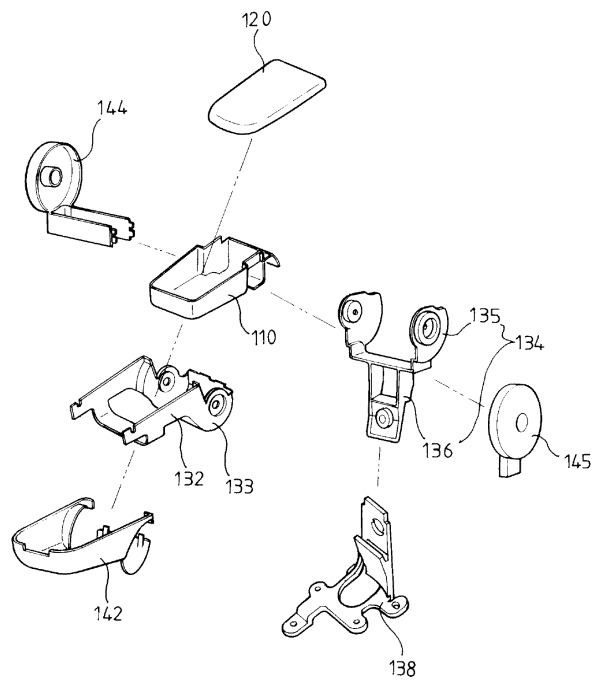

4

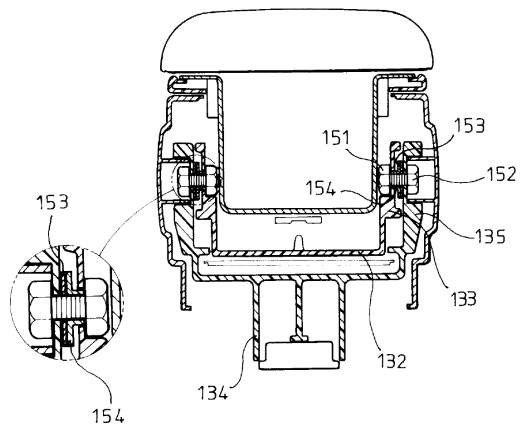

5

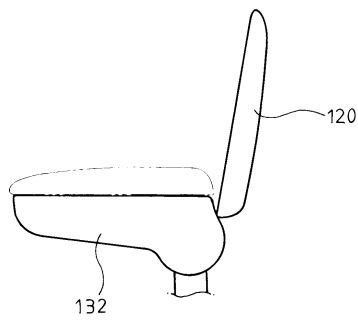

6

