



- (51) International Patent Classification:
F16F 1/12 (2006.01)
- (21) International Application Number:
PCT/US2014/022792
- (22) International Filing Date:
10 March 2014 (10.03.2014)
- (25) Filing Language: English
- (26) Publication Language: English
- (30) Priority Data:
13/829,830 14 March 2013 (14.03.2013) US
- (71) Applicant: **RENTON COIL SPRING COMPANY**
[US/US]; 425 S. 7th Street, P.O.Box 880, Renton, WA 98057 (US).
- (72) Inventor: **PEPKA, Charles, F.**; 425 S. 7th Street, P.O.Box 880, Renton, WA 98057 (US).
- (74) Agent: **JONES, Darren, J.**; Lowe Graham Jones PLLC, 701 Fifth Avenue, Suite 4800, Seattle, WA 98104 (US).
- (81) Designated States (unless otherwise indicated, for every kind of national protection available): AE, AG, AL, AM,

AO, AT, AU, AZ, BA, BB, BG, BH, BN, BR, BW, BY, BZ, CA, CH, CL, CN, CO, CR, CU, CZ, DE, DK, DM, DO, DZ, EC, EE, EG, ES, FI, GB, GD, GE, GH, GM, GT, HN, HR, HU, ID, IL, IN, IR, IS, JP, KE, KG, KN, KP, KR, KZ, LA, LC, LK, LR, LS, LT, LU, LY, MA, MD, ME, MG, MK, MN, MW, MX, MY, MZ, NA, NG, NI, NO, NZ, OM, PA, PE, PG, PH, PL, PT, QA, RO, RS, RU, RW, SA, SC, SD, SE, SG, SK, SL, SM, ST, SV, SY, TH, TJ, TM, TN, TR, TT, TZ, UA, UG, US, UZ, VC, VN, ZA, ZM, ZW.

(84) Designated States (unless otherwise indicated, for every kind of regional protection available): ARIPO (BW, GH, GM, KE, LR, LS, MW, MZ, NA, RW, SD, SL, SZ, TZ, UG, ZM, ZW), Eurasian (AM, AZ, BY, KG, KZ, RU, TJ, TM), European (AL, AT, BE, BG, CH, CY, CZ, DE, DK, EE, ES, FI, FR, GB, GR, HR, HU, IE, IS, IT, LT, LU, LV, MC, MK, MT, NL, NO, PL, PT, RO, RS, SE, SI, SK, SM, TR), OAPI (BF, BJ, CF, CG, CL, CM, GA, GN, GQ, GW, KM, ML, MR, NE, SN, TD, TG).

Published:

— with international search report (Art. 21(3))

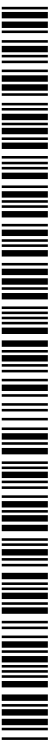

WO 2014/164555 A1

(54) Title: TENSION SPRING MOUNT WITH FRICTION-RESISTANT COATING

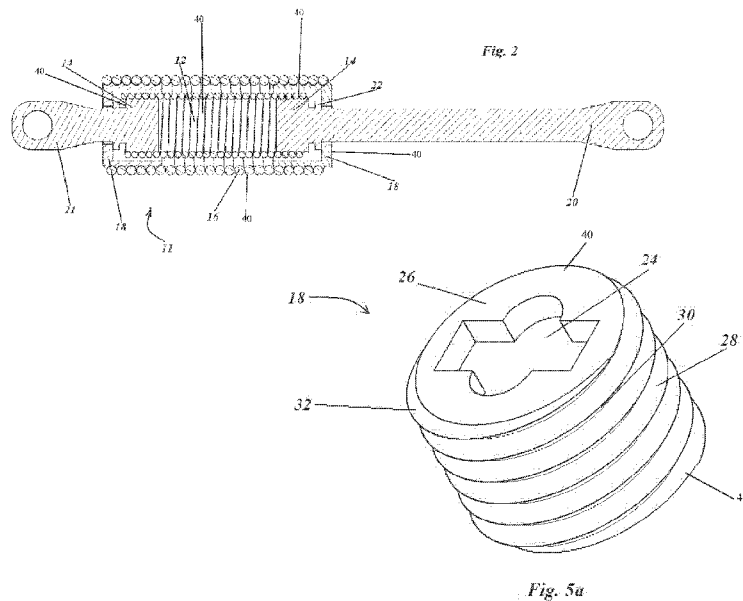

(57) Abstract: End mounts (14, 18) are used to secure a helical tension spring (12, 16) to end fixtures with various shapes and sizes. These end mounts (18) contain an inner hole to encase the inner spring end mount (14) and secure the end mount (18) making it like a cap. There is also a keyhole (24) created in the top surface that goes through the end mount (18) allowing it to fit over the fixtures but not over the inner end mount (14), holding it in place. Grooves (28) are machined in a helical pattern on the cylindrical side wall of the end mount. The spring (16) is wound onto the grooves of the end mount (18). A friction-resistant coating (40) is applied between components of the assembly to mitigate wear and to prevent bending and twisting.

TENSION SPRING MOUNT WITH FRICTION-RESISTANT COATING

INVENTOR
Charles F. Pepka

FIELD OF THE INVENTION

[0001] This invention relates generally to mounts for springs and, more specifically, to end-mounting tension springs and associated friction-resistant coatings.

BACKGROUND OF THE INVENTION

[0002] Nested springs are used for various applications. For example, they can be used in the landing gear of airplanes, or on any type of device for securing fixtures to a relatively moving component. They have been used where reliability is paramount or in some situations to reduce the space envelope required where the spring is mounted. Examples of applications of nested springs are throttle return springs, brake return springs, and valve springs.

[0003] Often, nested springs are used to avoid single-point failures by providing a redundant system. They replace a single-spring system. In a single-spring system however, when the spring fails, the whole system fails. Having a dual spring system increases the factor of safety. If one spring fails, the other can still properly function for a time until the broken spring is replaced. In some cases, the springs wear, twist, or bend excessively where portions of the spring contact one another. The effect is worsened where the contact is acute, such as with a small contact surface area under high load.

Also, some materials are abrasive, such as Titanium, and wear more quickly than other materials.

SUMMARY OF THE INVENTION

[0004] The present invention relates to mounts for springs. More specifically, the present invention comprises an end-mount system for tension springs to attach to fixtures in various applications using grooves and spring tension to keep the spring and fixtures secured together. The system comprises an inner spring and end mount along with an outer spring, encasing the inner spring, and outer end mount resting on the inner end mount. These are attached to fixtures on either end, which can differ depending on the application.

[0005] In accordance with further aspects of the invention, the end mounts are cylindrical in shape to allow for the helical tension spring to be secured to the end mount by way of being wound onto grooves on the end mount. The grooves of the end mount in one embodiment have a greater pitch than the pitch of the tension spring before being secured to the mount. In a preferred embodiment, the pitch of the mounting portion of the spring has a greater pitch than the remainder of the spring, to match the pitch of the mount grooves. The inner diameter of the grooves is slightly larger than the coil diameter of the spring. As the spring is tensioned the increased inward forces of the spring hold the spring on the end mount in a fashion similar to a Chinese finger trap. If the spring were free of the end mount these forces would tend to reduce the spring diameter all along the spring.

[0006] In accordance with other aspects of the invention, the end mounts have keyholes to fit over end fixtures. The keyholes are shaped so that the end mount fits over the fixture but not over the inner spring and inner end mount. The keyhole can be any shape as long as it fills this purpose.

[0007] In accordance with still further aspects of the invention, the fixtures are machined or attached to the inner spring end mount. These fixtures can be a variety of shapes and sizes depending on the application at hand.

[0008] In accordance with yet other aspects of the invention, a dual spring system, with an outer spring encasing an inner spring, allows each spring to be reduced in mass and the strength of the system increases greatly. In addition, a measure of safety is added with another spring introduced to the system. The resonant frequency of the combined spring system is also dramatically changed in comparison to a single spring system for the same application. This change in frequency can also be used to increase the safety of the overall system by avoiding dangerous frequency coupling.

[0009] As may be appreciated from the foregoing summary, the invention provides a more secure and clean attachment that adds a factor of safety, is reliable in spring attachments without fasteners, and saves weight.

BRIEF DESCRIPTION OF THE DRAWINGS

[0010] Preferred and alternative embodiments of the present invention are described in detail below with reference to the following drawings:

[0011] FIGURE 1 is a side view of a prior-art nested tension spring arrangement,

[0012] FIGURE 2 is a side view of the spring assembly,

[0013] FIGURE 3 is a side view of the inner portion spring assembly,

[0014] FIGURE 4 is a side view of the outer spring assembly,

[0015] FIGURE 5a is an isometric view of the outer spring end mount,

[0016] FIGURE 5b is an end view of the outer spring end mount having a wider key-hole opening, and

[0017] FIGURE 5c is a side view of the outer spring end mount.

[0018] FIGURE 6 is a side view of the outer portion spring assembly.

[0019] FIGURE 7 is an isometric view of an end mount with a machined channel and a friction-resistant coating in the channel.

DETAILED DESCRIPTION OF THE PREFERRED EMBODIMENT

[0020] As illustrated in Figure 1, prior-art nested tension springs 4, 6 use opposing hooks to restrain the spring from releasing from their mount locations. The

outer hook 10 opposes the inner hook 8. It is to be noted that the previous tension springs 4, 6 typically failed at the hook most particularly at the location where the large bending stress on the hook met the large torsion stress coming from the coil under a tensile load. The relationship of the hooks 8, 10 to the springs 4, 6 will be better understood after the following description. The operation of the springs 4, 6 may be understood upon reference to Fig. 1. The embodiment consists of two tensions springs 4, 6, an inner spring 4 and an outer spring 6. The above springs 4, 6 connect at hooks 8, 10 on either end. These springs 4, 6 are assembled together so that the coiled spirals are wound in opposing directions. The hooks 8, 10 however, are connected to fixtures in such a manner that upon application of repeated tensile forces the hooks may fail. These hooks 8, 10 do not have a clean or secure attachment. Stress concentrations arise at the fixture or element to which the hooks secure and at the bend in the hooks prior to the windings. Also with the prior art, when one spring fails, the hooks move, often causing the entire system to fail.

[0021] To resolve the difficulty noted above, embodiments of the present invention include an inner spring 12 and an outer spring 16 that are connected to fixtures with end mounts 14, 18 in such a manner that upon application of tensile forces there is much less chance for failure and a more secure and clean attachment. These end mounts 14, 18 may be machined from various materials such as metals, plastics, or composites. The relationship of the end mounts 14, 18 to the embodiment will be better understood upon reference to Fig. 2.

[0022] Figure 2 shows a spring assembly 11 including an inner spring 12 attached to fixtures 20, 21 with end mounts 14 on either end. Surrounding the inner spring 12 is the outer spring 16 wound onto end mounts 18. Any component of the spring assembly 11 can have a coating 40 applied to the outer surface to ease friction, prevent bending, twisting, and other wear that may occur between contacting portions of the spring assembly 11. The springs 12, 16, the end fittings 14, 18, and any other component of the assembly 11 can have the coating 40. The coating 40 can be between any two contacting surfaces. The coating 40 can be applied to either one of the contacting surfaces

or to both contacting surfaces. For example, the coating 40 can be applied to the grooves of the end fittings 14, 18, or to the springs 12, 16, or to both the end fittings 14, 18 and the springs 12, 16. The coating 40 can be a Nylon material, such as Nylon 11 or another suitable coating material. The coating 40 can be any suitable thickness. In some embodiments the coating 40 is approximately 0.011 inches thick. The coating 40 can be applied through a powder coating application method to the external surface of the springs 12, 16. In some embodiments the springs 12, 16 are made of a material such as 15-5 ph stainless steel or titanium. Some materials wear more quickly than others. In particular, titanium is abrasive and may wear through other contacting materials if subjected to sufficient stress. The coating 40 minimizes wear from twisting, bending, and other deformation as well as from friction.

[0023] The assembly 11 includes more than one spring, so each individual spring can have a lower mass as strength from multiple springs is combined. As a result of the lower mass of each individual spring in the system, the dual-spring embodiment has a higher intrinsic natural frequency. This higher natural frequency adds safety as the frequency is out of the range of frequencies experienced in use. When the apparatus experiences frequencies similar to its natural frequency it can more easily fail. This has been seen in airplane landing gear. Because the natural frequency of the system is higher a measure of safety is added.

[0024] Returning to the end mounts 18, the inner diameter of the grooves 28 in end mounts 18 is slightly larger than the resting coil diameter of the outer spring 16. For this reason, coupled with the fact that the mentioned springs are tension springs, as the spring is introduced to tension the spring diameter naturally tends to decrease, however, the end mount 18 forces the coil diameter to remain the same on the end mounts 18. This makes the outer spring 16 compress around the end mount 18, holding it on securely without slippage. The coating 40 mitigates wear between the spring 16 and the end mount 18, which is especially beneficial given the pressure created between these two members when the spring 16 is in tension and therefore constricts around the end mount 18.

Slippage in the axial direction is prevented by the end mount 18, but the coating 40 can allow the spring 16 to move slightly relative to the end mount 18 in a circumferential direction as the spring 16 is tensioned. During tensioning of the spring a slight twist is induced in the spring. Slight movement of the spring away from the end mount occurs, especially where the spring exits the end mount. The coating 40 applied to the groove of the end mount where the spring exits provides a smooth, durable interface to resist wear on the mount and the spring.

[0025] Also notable to mention, in some embodiments the grooves 28 in which the outer spring rests in the end mounts 18 may be spaced further apart than the natural pitch of the outer spring 16. This creates an associated tension on the grooves 28 of the end mount 18 as the outer spring 16 tries to recoil to its free length. In the preferred embodiment, the ends of the springs are manufactured with a greater pitch to more closely match the pitch of grooves 28. Such springs are easier to secure to the mounts. However, slippage is still avoided due to the tighter grip of the spring upon tensioning, as discussed above.

[0026] Another advantage these end mounts 18 provide for the embodiment is that if one spring fails the end mounts 14, 18 hold the other spring in the same alignment. With the prior art the hooks 8, 10 move when one spring fails. Such movement can be a problem, especially with a tight space envelope or if the springs are near a fuel tank or other combustible where a spark may be an issue. The coating 40 further prevents friction that may cause sparks, further mitigating this risk. Furthermore, since conventional fasteners are eliminated, failures are further reduced. There are fewer parts to fail. The bending stresses are minimized and the torsional stresses are spread over multiple coils in the end-mounting region.

[0027] Turning now to the end mount 18 more specifically as seen in Fig. 5, there is a keyhole 24 created. This keyhole 24 extends through wall 26 of end mount 18 in order that the end mount 18 may fit over the end fixtures 20 and 21 attached to the outer spring. The keyhole 24 has the shape as shown on the wall 26 of the end mount.

The hole shape is configured to provide clearance for fitting over one end of the fixture while being small enough to engage the inner spring mount or other stop as discussed below. The wall 26 of the end mount is preferably a flat surface on which a snap ring 22 rests to hold the end mount 18 in place as shown in Fig. 2. The coating 40 can be applied to any suitable region of the end mount 18 or to the entire external surface. In some embodiments the external, grooved region that engages the spring 16 is coated, but the remainder is uncoated. Preferably, only the final portion of the groove is coated, adjacent the final winding of the spring on the end mount near the exit of the spring from the end mount.

[0028] The end mount 18 also preferably has a recess such that it can nest over the inner end mount 14 and the inner spring 12. An inner surface 36 of wall 26 in the end mount 18 rests on the inner end mount 14 or the flange 15, if a flange is used. Alternately to a flange, a separate stop, such as a washer may be used. The inner surface 36 can be coated as described above. The shape of the keyhole 24 may be specific to the fixture or can be a fixed shape such as a circle (as in FIGURE 5a). The keyhole 24 is created to allow the end mount 18 to fit over the end fixtures 20 and 21 attached to the outer spring 16 so that the spring 16 is able to be wound onto the end mounts 18. Fixtures 20 and 21 attached to the outer spring 16 may vary in shape, size and length depending on need from the desired application. Any portion of the fixtures 20, 21 can have a coating applied similar to what is described in detail above.

[0029] Also as noted in Fig. 5, the end mount 18 has a taper 32 which then turns into the grooves 28 that the outer spring 16 is wound onto. As previously noted, these grooves 28 may be spaced further apart than the natural resting pitch of the outer spring 16. The grooves 28 are constantly spaced and have a constant diameter. As the spring is wound onto the mount, the force to turn it on tends to enlarge the spring diameter. However, once mounted, the tensile forces during use tend to keep the spring securely mounted. The grooves 28 can have a coating 40 applied to help installation by reducing the friction between the end mount 18 and the spring 16. The coating 40 on the tapered

portion can be thicker and stiffer than on other portions of the assembly 11 to further mitigate wear and to further reduce twisting and bending. The angle of taper can be increased for an application calling for a thicker coating to create more space between the fitting and the spring in which the thicker coating will more easily fit.

[0030] The cylindrical side wall 30 of the end mount 18 is preferably generally constant in diameter along its length, except of course for the variation introduced by the grooves in the outer portion of the wall. The inner hole 34 has a constant diameter that is able to fit over inner end mount 14 and shoulder 15 or 17 (as seen in Figure 3). However, the inner hole 34 diameter is preferably tight enough around the inner end mount 14 and shoulder 15 or 17 that it does not slide around and come out of place. The inner hole surface 36 is preferably flat and perpendicular to the side wall 30 of the end mount 18. This allows the end mount 18 to rest on the shoulder 15 or the inner end mount 14 securely. The shoulder 15 can also be coated to mitigate wear and improve contact qualities similar to what is described above.

[0031] As shown in Fig. 2, the outer spring end mount 18 rests on the inner spring end mount 14. The inner spring end mount 14 has a machined shoulder 17 or a flange 15 with a wall 19, which serves the purpose of holding the outer spring 16 in place and provides a wall 19 for the outer spring end mount 18 to be fixed. Any surface of the end mount 14 can be coated with a coating similar to what is described above and for similar reasons. As a consequence of having two springs 12 and 16 in the assembly each spring can weigh less because of the added strength of including an additional spring. It is to be noted that the springs 12 and 16 coil in opposite directions. For this reason coupled with the fact that there are two tension springs 12 and 16, great strength is added to the apparatus. In some embodiments the inner spring 12 and outer spring 16 may contact one another. With the coating 40 applied to the external surface of the springs 12, 16, such contact does not adversely affect performance of the assembly 11.

[0032] As tension is added to the springs 12, 16 they pull in opposing directions because they are wound oppositely. Incidentally, it will be appreciated that a greater

factor of safety is added in the use of two springs 12, 16. As shown in Fig. 3 the apparatus is capable of functioning with the use of only one spring. The fixtures 20 and 21 are still securely connected and the embodiment can still function. Also, as shown in Fig. 4, the outer spring 16 can still function if the inner spring 12 fails. If one spring fails, the other one is still present and can function without the other. This added measure of safety is especially important as this device is often used in applications with high stress and multi-directional, vibrating, and/or high speed motion.

[0033] While the preferred embodiment of the invention has been illustrated and described, as noted above, many changes can be made without departing from the spirit and scope of the invention. For example, a safety rod could be added for an even higher measure of safety. Thus if both springs 12 and 16 were to fail, the rod would hold the fixtures together. The rod could be attached using keyholes from the rod into the fixtures.

[0034] Another example used in the application of securing the outer end mounts 18 could be the use of flanges. These flanges could take the place of the shoulder of the inner end mount. Flanges could be machined directly onto the fixtures 20 and 21 or arm of the fixture 20 and 21 depending on the application. These flanges would then hold the outer end mount 18 in place.

[0035] Also, depending on the fixture 20 and 21, differing sizes of outer end mounts 18 and keyholes may be used. In relation to the springs 12 and 16, differing sizes and materials may be used depending on the strength need and the function of the device. Free length, pitch, diameter, coil diameter, and the number of coils may all vary. Similarly the diameter of the outer end mounts 18 may vary depending on the outer spring 16 coil diameter and the size of the fixtures 20 and 21 attached.

[0036] Figure 7 illustrates an end mount 50 according to embodiments of the present disclosure in which a coating 40 has been applied to certain surfaces of the end mount 50. The end mount 50 is generally similar to other end mounts disclosed herein. The grooves of the end mount 50 come to an end 52. The final portion 54 of the groove is machined to have a slightly larger radius than the remainder of the coils to accommodate

the thickness of the coating 40. The coating 40 can be applied to this final portion 54. When the spring is threaded onto this end mount 50, the coils exit the mount at end 52. Thus, this final portion 54 encounters most of the spring twisting and rubbing in use. The coating 40 helps to lessen the wear and early failure of the springs and fittings. The dimensions of the final portion 54 can be varied for a given application depending on how much the spring moves along the final portion 54 during use. The wear caused by the contact of the spring ends and the end mount are mitigated.

[0037] The dual-spring system can alternatively be more than two springs, even as many as four or five springs. These do not necessarily have to be nested. They may be secured one next to the other, however, this does not necessarily reduce the space envelope. Accordingly, the scope of the invention is not limited by the disclosure of the preferred embodiment. Instead, the invention should be determined entirely by reference to the claims that follow.

The embodiments of the invention in which an exclusive property or privilege is claimed are defined as follows:

1. An end mount for a spring assembly, comprising:
 - a cylindrical body having helical grooves configured to receive a coil spring wound onto the helical grooves;
 - a first end of the cylindrical body;
 - a second end of the cylindrical body opposite the first end, wherein the second end is configured to receive the spring, wherein the grooves have a first radius corresponding to the diameter of the spring coils such that the individual coils rest within the grooves in a threaded manner; and
 - a friction-resistant coating formed in at least the final portion of the second end.
2. The end mount of Claim 1, wherein the first end has a key hole configured to permit an end fixture to pass therethrough.
3. The end mount of Claim 1, wherein an exterior shape of the end mount is tapered smaller from the second end to the first end.
4. The end mount of Claim 1, wherein the friction-resistant coating is a nylon material.
5. The end mount of Claim 1, wherein the end mount is made of stainless steel or titanium.
6. The end mount of Claim 1, wherein the friction-resistant coating is applied using a powder-coating technique.
7. The end mount of Claim 1, wherein the friction-resistant coating is approximately 0.011 inches thick.
8. The end mount of Claim 1, wherein the groove in the final portion of the second end has a second radius slightly larger than the first radius and wherein the friction resistant coating has a thickness approximately equal to a difference between the first and second radii.

9. An end mount for securing a first tension spring to an end fixture, the mount comprising:
 - a first mount body having curved sides and an end
 - grooves arranged in a helical configuration on the curved sides of the mount
 - body; and
 - a friction-resistant coating between a portion of the first mount body and the spring.
10. The end mount of Claim 9, wherein the friction-resistant coating is a nylon material.
11. The end mount of Claim 9, wherein at least one of the first mount body and the spring is made of titanium.
12. The end mount of Claim 9, wherein at least one of the first mount body and the spring is made of stainless steel.
13. The end mount of Claim 9, wherein the friction-resistant coating is approximately 0.011 inches thick.
14. The end mount of Claim 9, wherein the grooves having a coil diameter slightly larger than the coil diameter of the applied spring.
15. The end mount of Claim 14, wherein the grooves have a pitch larger than the natural pitch of the spring in use.
16. The end mount of Claim 9, wherein the curved sides form a cylindrical side wall with a constant diameter.
17. The end mount of Claim 16, wherein the cylindrical side wall has a constant length.
18. The end mount of Claim 16, wherein the grooves surround the outer cylindrical side wall of the end mount.
19. The end mount of Claim 9, wherein the end comprises a circular, flat wall.

20. The end mount of Claim 9, wherein the first mount body is at least partially hollow.
21. The end mount of Claim 9, wherein an inner surface of the first mount body is cylindrical in shape.
22. The end mount of Claim 21, wherein the inner surface has a constant diameter along its length.
23. The end mount of Claim 21, wherein an inner surface of the first mount body does not extend completely through the first mount body but stops before the end, an opening being provided in the end, the opening thus being smaller than the interior of the inner surface.
24. The end mount of Claim 9, wherein the end fixture has an outer end and wherein a keyhole is formed by the opening in the end of the mount body, the keyhole being configured to allow passage of the outer end of the end fixture.
25. The end mount of Claim 24, wherein the keyhole has a round shape.
26. The end mount of Claim 24, wherein the keyhole is centered on the end of the mount body.
27. The end mount of Claim 24, wherein the end fixture includes an inner end mount, and wherein the keyhole fits over the outer end but does not fit over the inner end mount.
28. The end mount of Claim 9, wherein the grooves have a constant diameter along the curved sides of the end mount.
29. The end mount of Claim 9, wherein the grooves have a constant pitch along the curved sides of the end mount.
30. The end mount of Claim 9, further comprising a second mount body for securing a second tension spring at least partially within the first tension spring, wherein the first mount body has a greater diameter than the second mount body.

31. A tension spring mount assembly for coupling between a first component and a second component to control movement between the first and second components, the assembly comprising:
 - a first fixture configured for mounting to the first component, the first fixture having an inner end and an outer end, the outer end configured for mounting to the first component, the inner end having an abutment;
 - a second fixture configured for mounting to the second component, the second fixture having an inner end and an outer end for mounting to the second component;
 - a first tension spring coupled between the first and the second fixtures, the first spring having a first end coupled to the first fixture and a second end coupled to the second fixture;
 - a first spring mount coupling the first end of the first tension spring to the first fixture inner end; and
 - a friction-resistant coating between any two or more of the first fixture, the first component, the abutment, the second fixture, the second component, and the first tension spring, the first spring mount.
32. The tension spring mount assembly of Claim 31, wherein the friction-resistant coating is a nylon material.
33. The tension spring mount assembly of Claim 31, wherein the friction-resistant coating is applied using a powder-coating technique.
34. The tension spring mount assembly of Claim 31, wherein at least one of the first mount body and the spring is made of titanium.
35. The tension spring mount assembly of Claim 31, wherein at least one of the first mount body and the spring is made of stainless steel.
36. The tension spring mount assembly of Claim 31, wherein the friction-resistant coating is approximately 0.011 inches thick.

37. The tension spring mount assembly of Claim 31, further comprising a first inner spring mount secured to the first fixture and a second spring secured to the first inner spring mount, the second spring being at least partially nested within the first spring.
38. The tension spring mount assembly of Claim 31, wherein the first inner spring mount is the abutment securing the first spring mount.
39. The tension spring mount assembly of Claim 31, further comprising a second spring mount coupled between the first spring and the second fixture, the second spring mount having an outer surface about which the first spring is wound, the second spring mount sliding over a portion of the second fixture, the second fixture having an abutment to secure the second spring mount from movement toward the inner end of the second fixture.
40. The tension spring mount assembly of Claim 31, further comprising a second inner spring mount secured to the second fixture, the second spring being secured to the second inner spring mount.

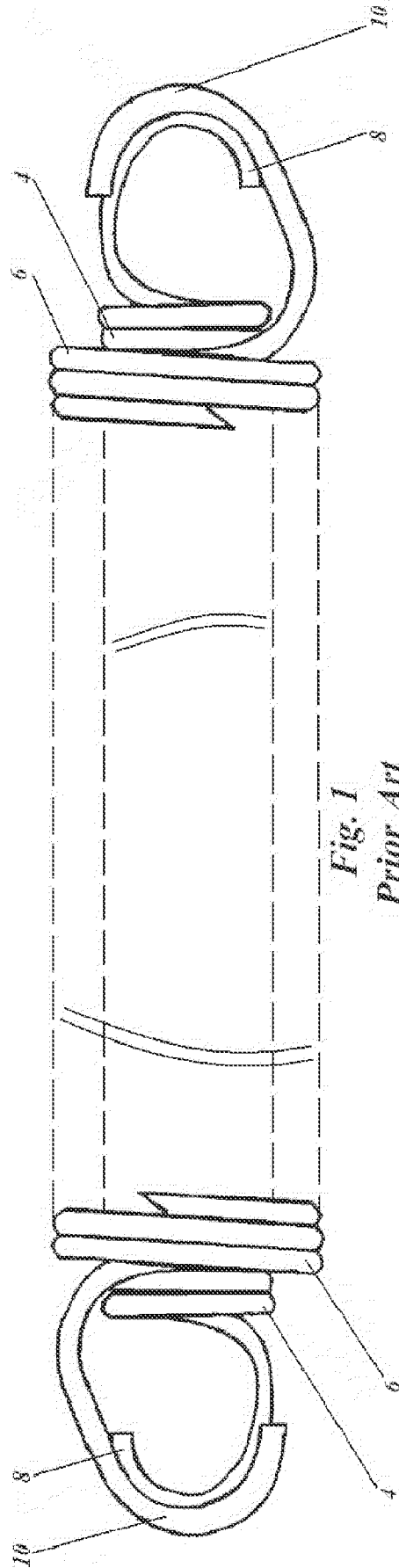

Fig. 1
Prior Art

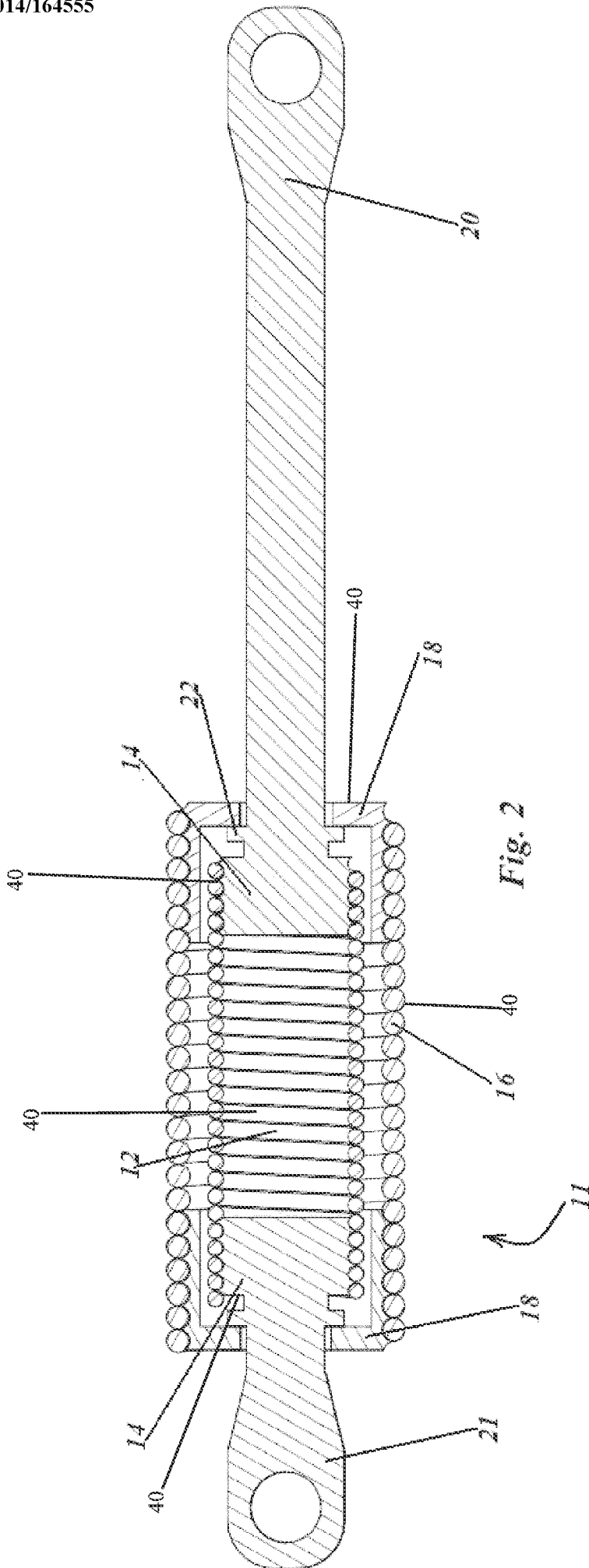

Fig. 2

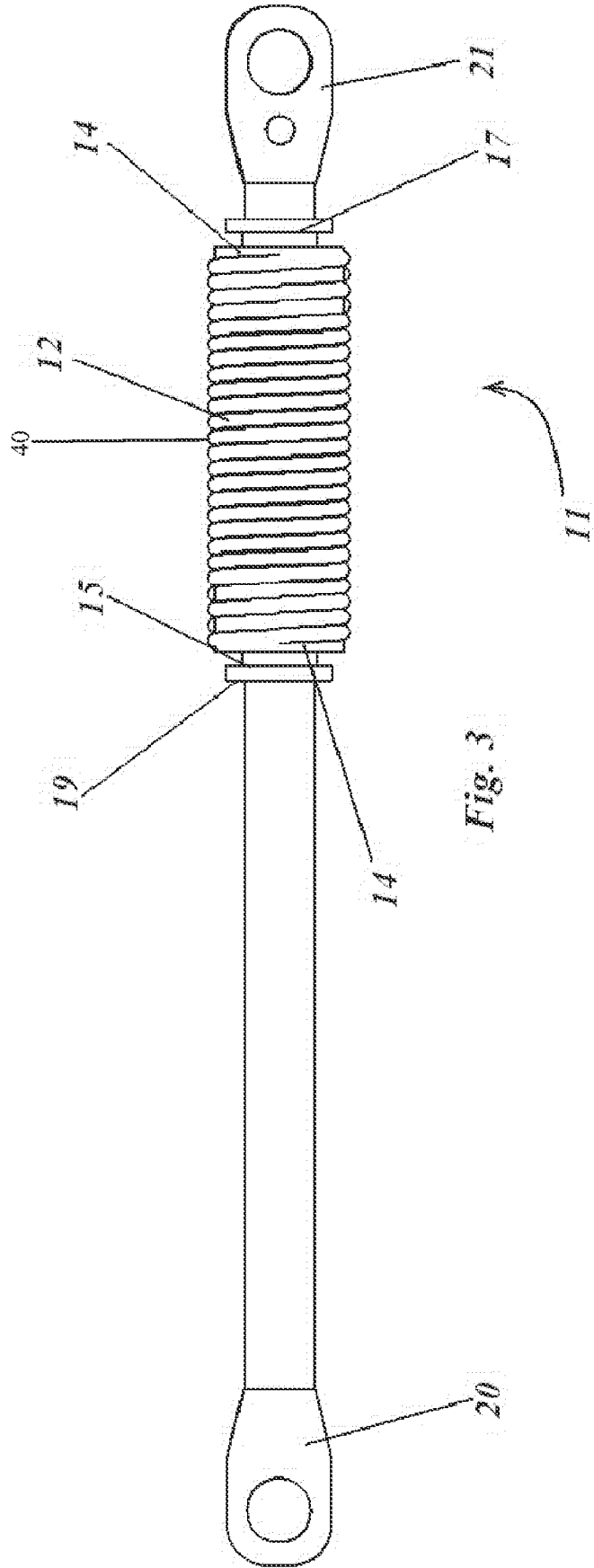

Fig. 3

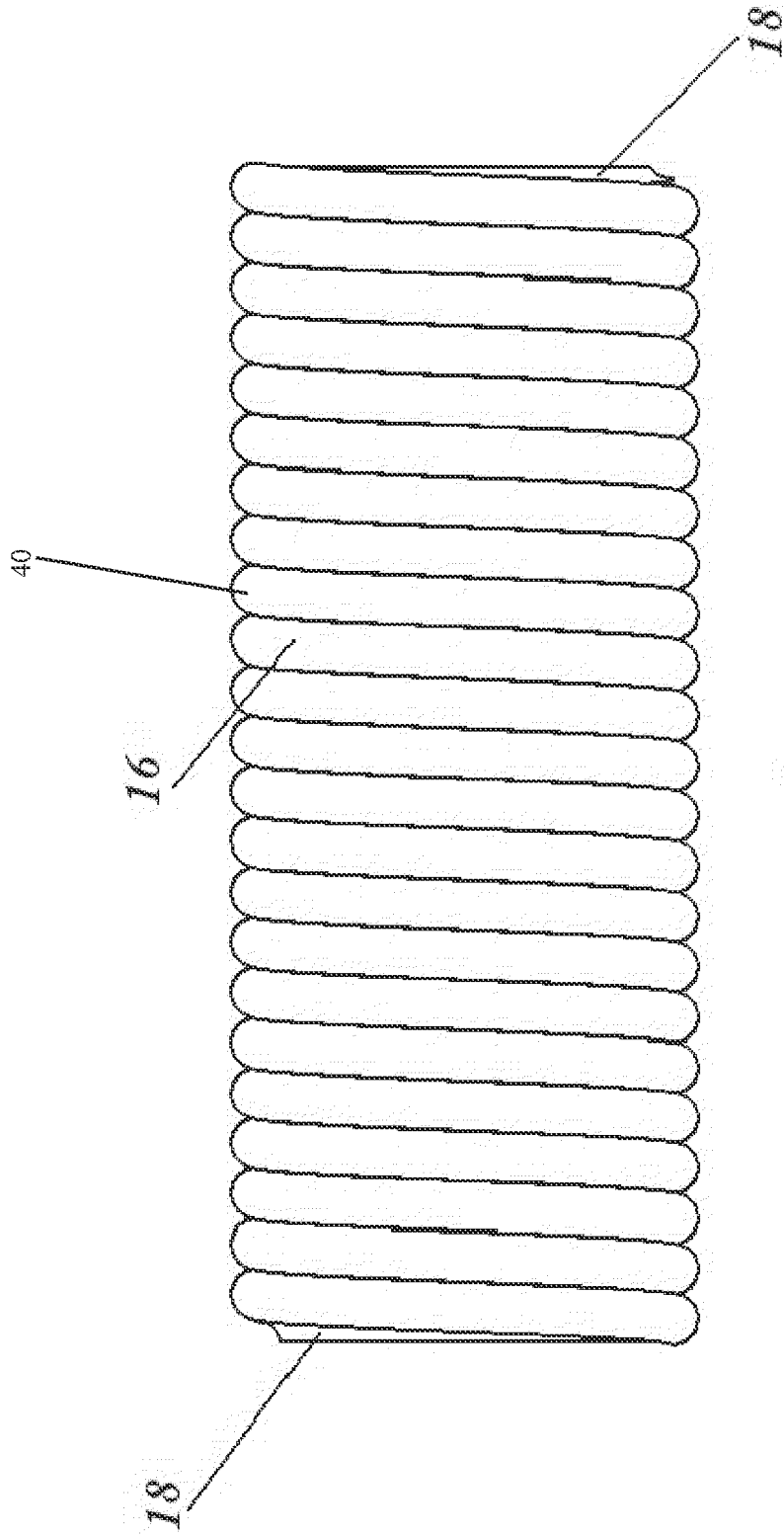

Fig. 4

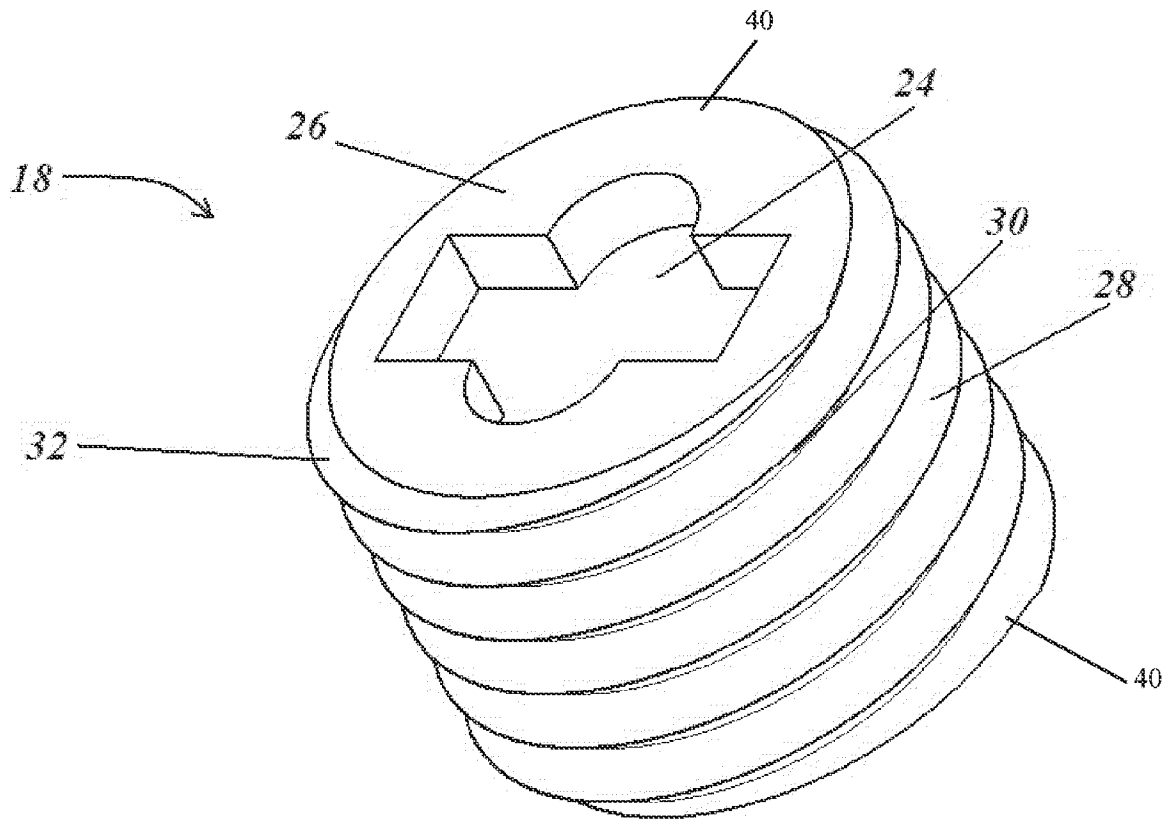

Fig. 5a

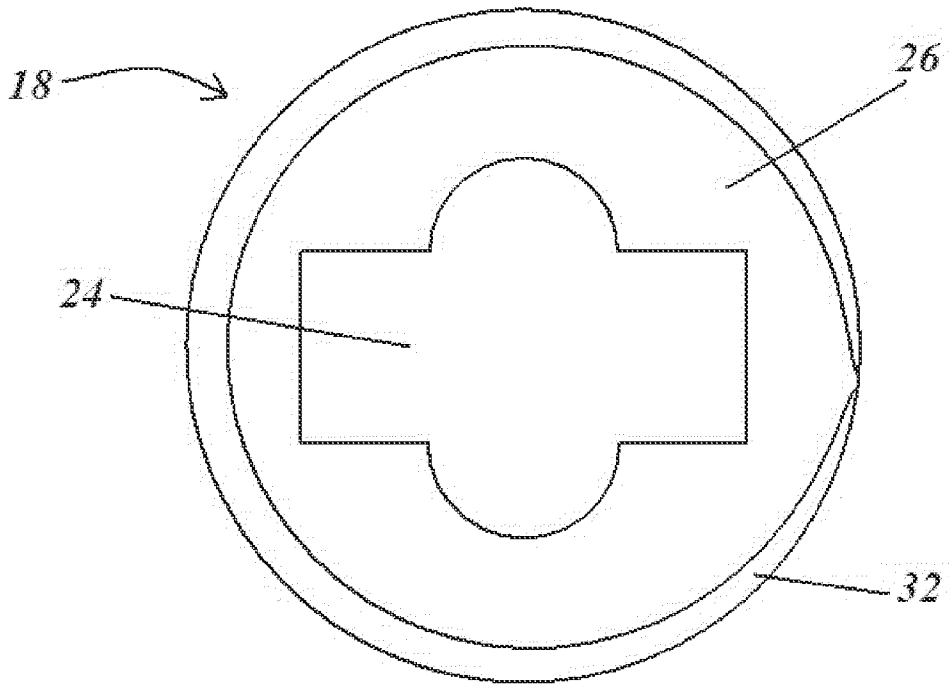

Fig. 5b

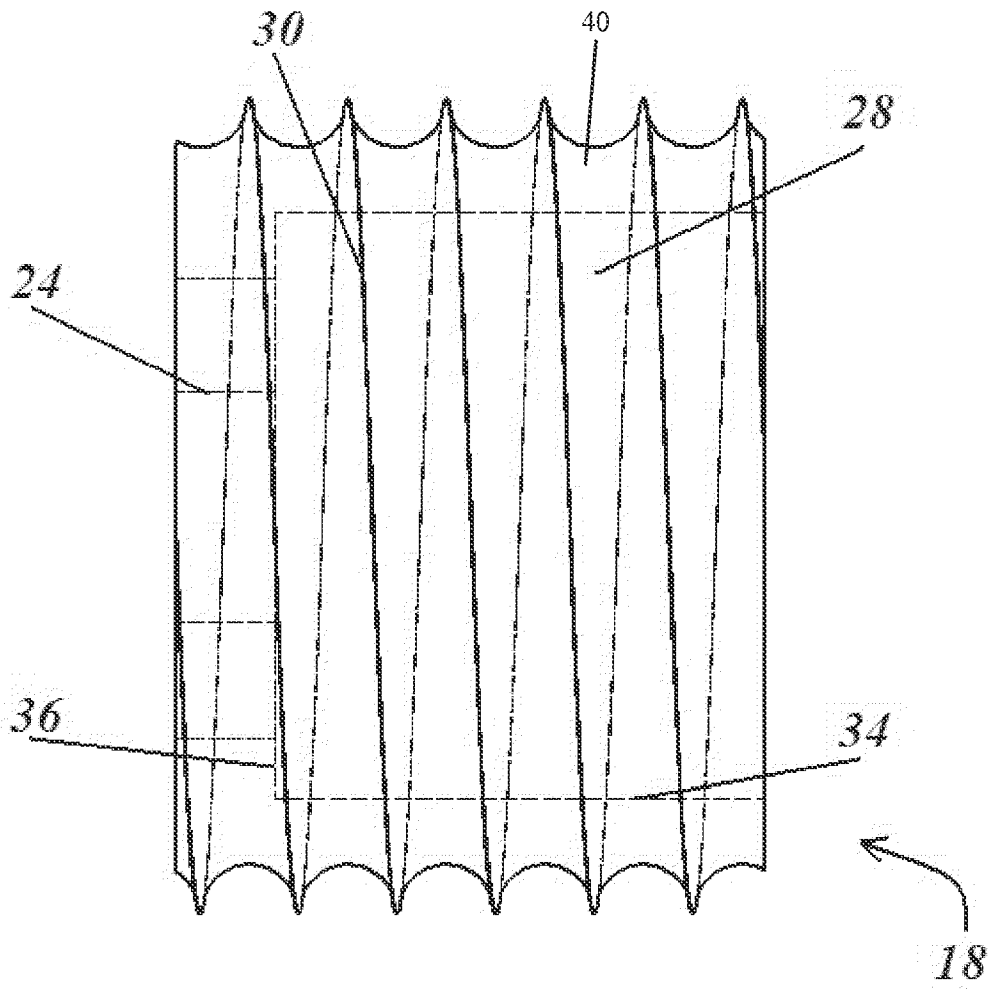

Fig. 5c

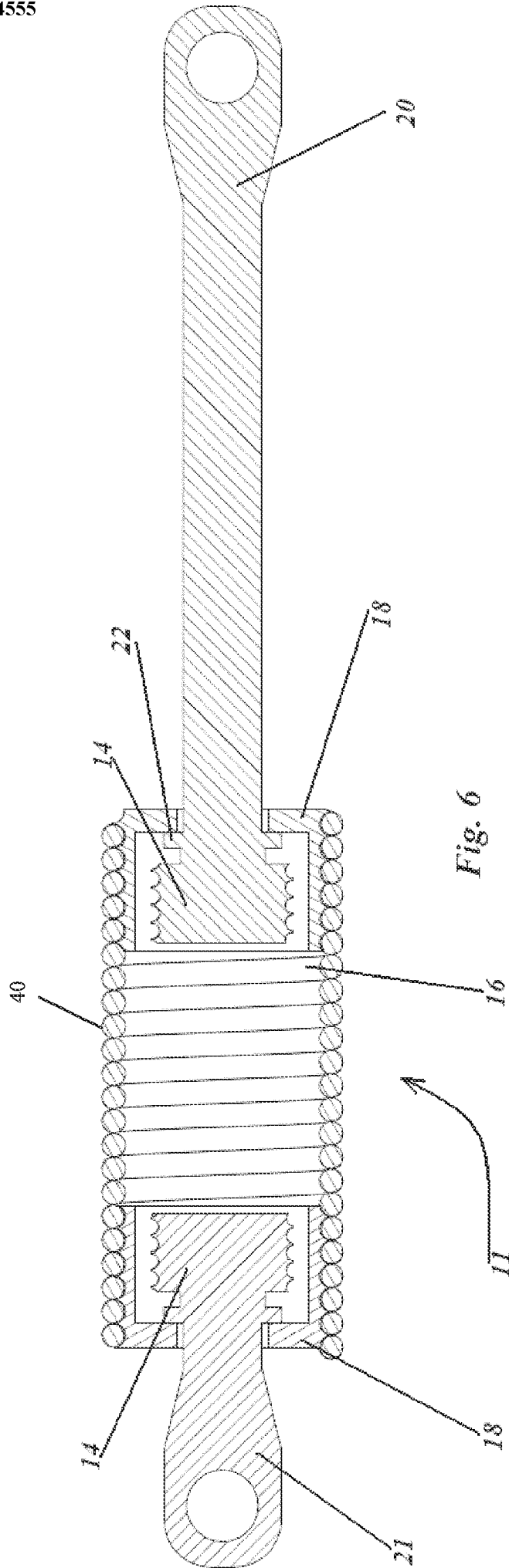
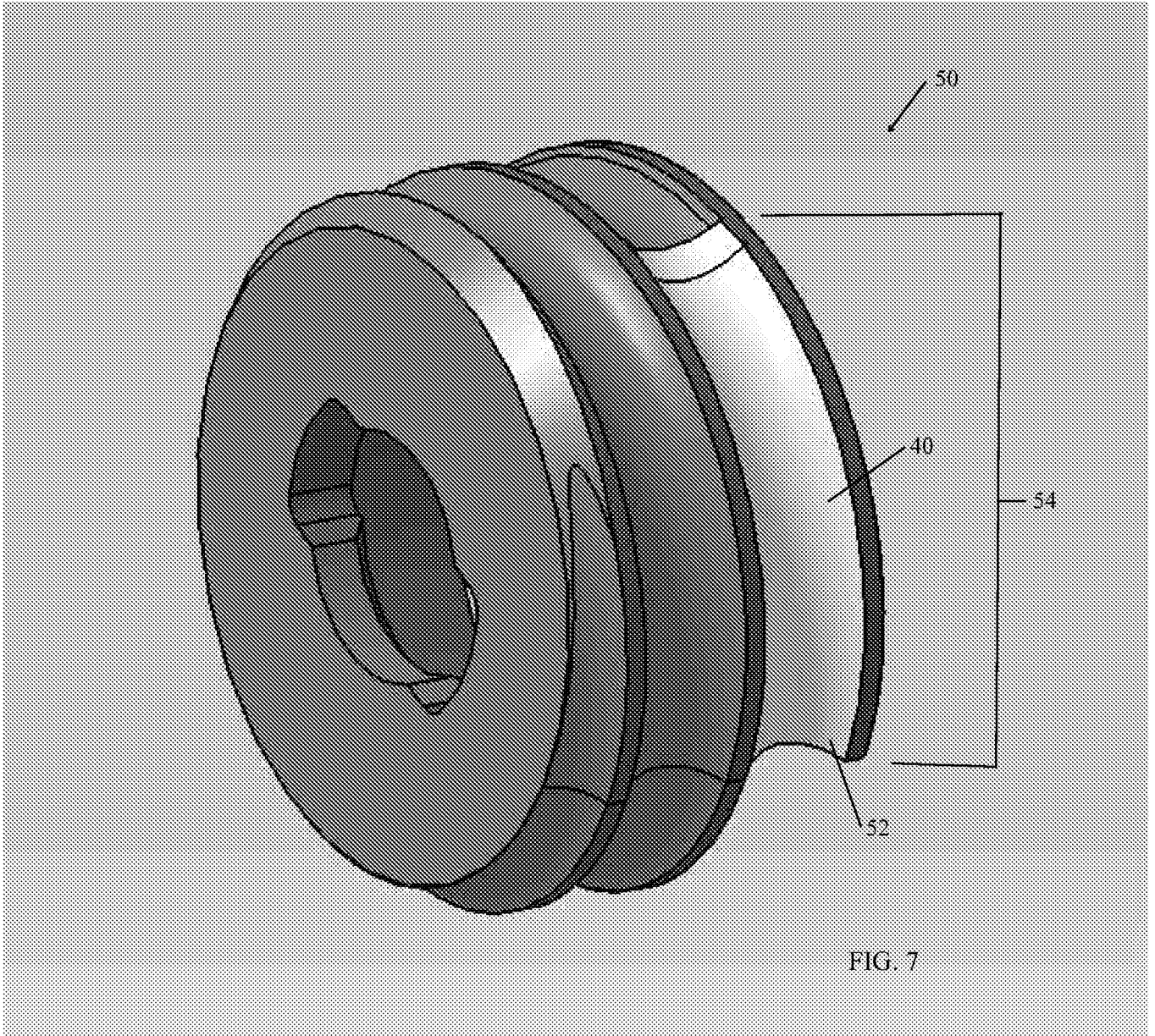

Fig. 6



INTERNATIONAL SEARCH REPORT

International application No
PCT/US2014/022792

A. CLASSIFICATION OF SUBJECT MATTER
INV. F16F1/12
ADD.
According to International Patent Classification (IPC) or to both national classification and IPC

B. FIELDS SEARCHED
Minimum documentation searched (classification system followed by classification symbols)
F16F

Documentation searched other than minimum documentation to the extent that such documents are included in the fields searched

Electronic data base consulted during the international search (name of data base and, where practicable, search terms used)
EPO-Internal, WPI Data

C. DOCUMENTS CONSIDERED TO BE RELEVANT

Category*	Citation of document, with indication, where appropriate, of the relevant passages	Relevant to claim No.
X	DE 36 31 233 A1 (DAIMLER BENZ AG [DE]) 24 March 1988 (1988-03-24)	1,3,5-7
A	figures 1,3 column 5, line 5 - line 9 column 5, line 43 - line 47	8
X	US 2011/204550 A1 (PEPKA CHARLES F [US]) 25 August 2011 (2011-08-25)	1,2,4-7, 9-14, 16-40
Y	figures 2,5a-5c,6	15
A		3,8
X	WO 2011/094163 A1 (EMERSON ELECTRIC CO [US]; BABB LARRY F [US]) 4 August 2011 (2011-08-04)	1,2,5-7, 9,11-14, 16-19, 28,29
	figures 7,9 page 1, paragraph 47	
	----- -/--	

Further documents are listed in the continuation of Box C.

See patent family annex.

* Special categories of cited documents :

"A" document defining the general state of the art which is not considered to be of particular relevance

"E" earlier application or patent but published on or after the international filing date

"L" document which may throw doubts on priority claim(s) or which is cited to establish the publication date of another citation or other special reason (as specified)

"O" document referring to an oral disclosure, use, exhibition or other means

"P" document published prior to the international filing date but later than the priority date claimed

"T" later document published after the international filing date or priority date and not in conflict with the application but cited to understand the principle or theory underlying the invention

"X" document of particular relevance; the claimed invention cannot be considered novel or cannot be considered to involve an inventive step when the document is taken alone

"Y" document of particular relevance; the claimed invention cannot be considered to involve an inventive step when the document is combined with one or more other such documents, such combination being obvious to a person skilled in the art

"&" document member of the same patent family

Date of the actual completion of the international search

10 July 2014

Date of mailing of the international search report

18/07/2014

Name and mailing address of the ISA/

European Patent Office, P.B. 5818 Patentlaan 2
NL - 2280 HV Rijswijk
Tel. (+31-70) 340-2040,
Fax: (+31-70) 340-3016

Authorized officer

Kovács, Endre

TENSION SPRING MOUNT WITH FRICTION-RESISTANT COATING

End mounts (14, 18) are used to secure a helical tension spring (12, 16) to end fixtures with various shapes and sizes. These end mounts (18) contain an inner hole to encase the inner spring end mount (14) and secure the end mount (18) making it like a cap. There is also a keyhole (24) created in the top surface that goes through the end mount (18) allowing it to fit over the fixtures but not over the inner end mount (14), holding it in place. Grooves (28) are machined in a helical pattern on the cylindrical side wall of the end mount. The spring (16) is wound onto the grooves of the end mount (18). A friction-resistant coating (40) is applied between components of the assembly to mitigate wear and to prevent bending and twisting.

INTERNATIONAL SEARCH REPORT

International application No
PCT/US2014/022792

C(Continuation). DOCUMENTS CONSIDERED TO BE RELEVANT		
Category*	Citation of document, with indication, where appropriate, of the relevant passages	Relevant to claim No.
A	EP 1 624 219 A1 (BARNES GROUP INC [US]) 8 February 2006 (2006-02-08) page 4, column 5, line 50 - line 55 page 4, column 6, line 30 - line 39 -----	1,4,6,7
A	US 2005/092961 A1 (UCMAN ROBERT C [US]) 5 May 2005 (2005-05-05) figure 5 page 1, paragraphs 3,5 -----	1,7,9,31
Y	DE 10 2011 108852 A1 (LIEBHERR AEROSPACE GMBH [DE]) 31 January 2013 (2013-01-31) page 2, paragraphs 4,15 figures 1,4 -----	15
A		5,11,12, 34,35

INTERNATIONAL SEARCH REPORT

Information on patent family members

International application No PCT/US2014/022792

Patent document cited in search report	Publication date	Patent family member(s)	Publication date
DE 3631233	A1	24-03-1988	NONE

US 2011204550	A1	25-08-2011	EP 2539600 A2 02-01-2013
		JP 2013520634 A	06-06-2013
		US 2011204550 A1	25-08-2011
		WO 2011106260 A2	01-09-2011

WO 2011094163	A1	04-08-2011	US 2011182656 A1 28-07-2011
		WO 2011094163 A1	04-08-2011

EP 1624219	A1	08-02-2006	AU 2005201663 A1 23-02-2006
		CA 2504337 A1	04-02-2006
		EP 1624219 A1	08-02-2006
		NZ 540191 A	24-02-2006
		US 2006027955 A1	09-02-2006
		US 2007001356 A1	04-01-2007

US 2005092961	A1	05-05-2005	NONE

DE 102011108852	A1	31-01-2013	CA 2842909 A1 31-01-2013
		CN 103890438 A	25-06-2014
		DE 102011108852 A1	31-01-2013
		EP 2739876 A1	11-06-2014
		US 2014159296 A1	12-06-2014
		WO 2013013804 A1	31-01-2013
