

(19) **DANMARK**

(10) **DK/EP 3485181 T3**



(12) **Oversættelse af
europæisk patentskrift**

Patent- og
Varemærkestyrelsen

-
- (51) Int.Cl.: **F 16 G 11/10 (2006.01)** **F 16 B 21/02 (2006.01)** **F 16 B 21/06 (2006.01)**
F 16 M 11/04 (2006.01) **F 16 M 13/02 (2006.01)** **F 21 V 21/104 (2006.01)**
F 21 V 21/112 (2006.01) **F 21 V 21/16 (2006.01)** **F 21 V 21/18 (2006.01)**
- (45) Oversættelsen bekendtgjort den: **2023-05-15**
- (80) Dato for Den Europæiske Patentmyndigheds bekendtgørelse om meddelelse af patentet: **2023-03-01**
- (86) Europæisk ansøgning nr.: **17754770.0**
- (86) Europæisk indleveringsdag: **2017-07-06**
- (87) Den europæiske ansøgnings publiceringsdag: **2019-05-22**
- (86) International ansøgning nr.: **GB2017000104**
- (87) Internationalt publikationsnr.: **WO2018011533**
- (30) Prioritet: **2016-07-14 GB 201612234**
- (84) Designerede stater: **AL AT BE BG CH CY CZ DE DK EE ES FI FR GR HR HU IE IS IT LI LT LU LV MC MK MT NL NO PL PT RO RS SE SI SK SM TR**
- (73) Patenthaver: **Gripple Limited, The Old West Gun Works , Saville Street East, Sheffield, South Yorkshire S4 7UQ, Storbritannien**
- (72) Opfinder: **HEPWORTH, Robert, 133 Dykes Hall Road, Hillsborough, Sheffield, South Yorkshire S6 4GR, Storbritannien**
- (74) Fuldmægtig i Danmark: **Novagraaf Brevets, Bâtiment O2, 2 rue Sarah Bernhardt CS90017, F-92665 Asnières-sur-Seine cedex, Frankrig**
- (54) Benævnelse: **FORBEDRINGER I ELLER VEDRØRENDE FORBINDELSESINDRETNINGER**
- (56) Fremdragne publikationer:
FR-A1- 2 846 398
GB-A- 972 995
US-A- 5 417 400

DESCRIPTION

[0001] This invention relates to connecting devices. This invention also relates to connecting arrangements comprising connecting devices and carriers. More particularly, but not exclusively, this invention relates to connecting devices for suspending articles from supports.

[0002] It is often necessary to suspend carriers from ceilings or roofs. One end of a wire or cable can be secured to a suitable securing point in the roof and the opposite end to a connecting device. The connecting device is attached to the carrier. The connecting device can have a tendency to twist relative to the carrier and eventually work itself loose. Document FR2846398 discloses a similar device.

[0003] According to the invention, there is provided an attaching arrangement for attaching a connecting device to a first article, the attaching arrangement comprising:

an attaching member receivable through an opening in the first article; and

a locking arrangement for locking the connecting device to the first article, the locking arrangement comprising a detent formation configured to be received by said opening in the first article;

wherein the detent formation comprises a resilient member, the resilient member being receivable in said opening in the first article, and the resilient member being substantially V shaped, having opposite arms forming the V;

characterised in that the locking arrangement includes a mounting member for mounting the locking arrangement on the attaching arrangement, the mounting member being attached to one of the arms;

wherein the attaching arrangement has a fastening element to fasten the attaching arrangement to a securing arrangement, and the mounting member defines an aperture through which the fastening element extends to mount the locking arrangement on the attaching arrangement; and

wherein the locking arrangement further includes a release tab attached to the other of said arms to facilitate moving the arms towards each other.

[0004] According to a further aspect of this invention, there is provided a connecting device for connecting a first article to an elongate second article, the connecting device comprising: a securing arrangement for securing the device to the elongate second article; and an attaching arrangement as described above.

[0005] According to another aspect of this invention, there is provided a connecting

arrangement comprising: a connecting device and a first article, the connecting device comprising a securing arrangement for securing the connecting device to an elongate second article; and an attaching arrangement as described above.

[0006] According to another aspect of this invention, there is provided a method of connecting a first article to an elongate second article, the method comprising providing a connecting arrangement as described above, inserting the attaching arrangement through an opening in the first article and arranging the detent formation in said opening in the first article to lock the connecting device to the first article, wherein the method comprises manipulating the tab to move said arm attached thereto from a non-deformed position to a deformed position to release the resilient member from the opening in which the resilient member is received.

[0007] The first article may comprise a carrier. In one embodiment, the carrier may comprise a support, which may be elongate. The carrier may comprise an elongate strut. The elongate second article may comprise a cable, wire or other similar article.

[0008] The attaching arrangement may be rotatable relative to the first article to an attaching position to attach the connecting device to the first article. The detent formation may be receivable in the opening when the attaching arrangement is so rotated. The method may comprise rotating the attaching arrangement relative to the first article so that the detent formation is received in the opening in the first article.

[0009] The arms may be resiliently deformable away from, and towards, each other.

[0010] The arm attached to the mounting member may move from a resiliently deformed position to a non-deformed position when the attaching arrangement is moved to the attaching position. The movement of said arm from the deformed position to a non-deformed position may be a movement of the resilient member from a deformed position to a non-deformed position.

[0011] The moving of the arms towards each other may be to release the resilient member from the opening in which it is received.

[0012] The opening into which the resilient member is inserted may be the same as the opening through which the attaching arrangement is received. Alternatively, the opening into which the resilient member is inserted may be different from the opening through which the attaching arrangement is received.

[0013] The attaching member may comprise a first projecting portion for engaging the first article and a second projecting portion for insertion through the first article. When the second projecting portion is inserted through the first article, a region of the first article can be received between the first and second projecting portions, thereby attaching the connecting device to the first article.

[0014] The first projecting portion may engage a first face of said region of the first article. The second projecting portion may engage an opposite second face of said region of the first article.

[0015] In one embodiment of the connecting device for use with a first article defining an opening, the second projecting portion may be inserted through the opening in use.

[0016] The first article may comprise a main part, which may define an opening. The second projecting portion may be inserted through the opening, wherein when the second projecting portion is inserted through the opening, a region of the first article can be received between the first and second projecting portions, thereby attaching the connecting device to the first article.

[0017] The connecting arrangement may comprise a plurality of the connecting devices, which can be attached to the first article.

[0018] The aforesaid region of the first article may be received between the first and second projecting portions on rotating the attaching arrangement to an attaching position when the second projecting portion is inserted through the first article. The second projecting portion may extend across the first projecting portion.

[0019] The attaching member may further include a spacer portion extending between the first and second projecting portions. A gap may be defined between the first and second projecting portions.

[0020] The attaching arrangement may be rotated to the attaching position about an axis of rotation extending through the first and second projecting portions. When the attaching arrangement is rotated about the axis of rotation, a region of the first article may be received between the first and second projecting portions. The rotation of the attaching arrangement may be effected by rotation of the connecting device about the aforesaid axis of rotation.

[0021] According to the invention, the attaching member has a fastening element to fasten the attaching arrangement to the securing arrangement. The fastening element may extend between the first projecting portion and the securing arrangement. The fastening element may be threaded to threadably cooperate with corresponding threads on the securing arrangement.

[0022] The first projecting portion may extend outwardly from the fastening element. The second projecting portion may extend outwardly from the spacer portion. The second projecting portion may extend from the spacer portion in opposite directions relative thereto.

[0023] The second projecting portion may have a leading surface and a securing region. The leading surface may be the first region of the second projecting portion to pass over the aforesaid region of the first article when the attaching arrangement is rotated to the attaching position. The second projecting portion may have an attaching surface to engage the first article when the attaching arrangement is in the attaching position.

[0024] The gap may be larger at the leading surface than at the attaching surface. The leading surface may taper to the attaching surface.

[0025] The first projecting portion may extend radially from the fastening element, and may be substantially circular. The second projecting portion may be substantially rectangular having a width greater than its length.

[0026] The opening in the first article may be elongate and may have a length greater than the length of the second projecting portion. The width of the opening in the first article may be greater than the width of the second projecting portion. The length of the second projecting portion may be greater than the width of the opening.

[0027] The spacer portion may have a stop formation to prevent rotation of the attaching arrangement in one direction. The stop formation may comprise a region of the spacer portion configured to engage the first article when the attaching arrangement is rotated in the aforesaid direction. The stop formation may comprise diagonally opposite regions of the spacer portion, the distance between said regions being greater than the width of the opening.

[0028] The spacer portion may have a curved edge to allow rotating of the attaching arrangement relative to the first article. The spacer portion may have diametrically opposed curved edges, wherein the diametrical distance between said curved edges is less than the width of the opening in the first article.

[0029] The securing arrangement may comprise any suitable securing arrangement for securing the article to the connecting device.

[0030] At least one embodiment of the invention will now be described by way of example only, with reference to the accompanying drawings, in which:

Figure 1 is a front view of a connecting device;

Figure 2 is a side view of the connecting device shown in Figure 1;

Figure 3 is a perspective side view of the connecting device shown in Figure 1;

Figures 4A to 4C are top plan views showing the steps of attaching the connecting device to a first article to form a connecting arrangement; and

Figure 5A is a view along the lines A - A in Figure 4A;

Figure 5B is a view along the lines B - B in Figure 4B;

Figure 5C is a view along the lines C - C in Figure 4C;

Figure 6 is a side view of an attaching arrangement showing the locking arrangement mounted on the attaching member;

Figure 7 is a perspective view of a locking arrangement, being part of the attaching arrangement;

Figure 8 is a further perspective view of the locking arrangement;

Figure 9 is a perspective view of an attaching member, being part of the attaching arrangement;

Figure 10 is a side view of the attaching member; and

Figure 11 is a sectional side view of the connecting device.

[0031] Figures 1 to 3 show a connecting device 10 for use as part of a connecting arrangement 12 (see Figures 4A to 4C and 5A to 5C). The connecting arrangement 12 comprises the connecting device 10 and a first article in the form of a carrier comprising an elongate support 14.

[0032] The support 14 is in the form of an elongate strut comprising a main part 16 being formed of an elongate central strip 18 and two elongate substantially parallel transverse strips 20 extending from opposite edges of the central strip 18 so that the support 14 has an end profile that is substantially U shaped.

[0033] Openings in the form of elongate slots 22 are defined in the transverse strips 20 and in the central strip 18. The support 14 can be suspended from the roof or ceiling of a building so that items, for example pipes, can be attached thereto.

[0034] The connecting device 10 is provided to connect an elongate second article, in the form of a cable 24 to the support 14, and comprises a securing arrangement 25 for securing the cable 24 to the connecting device 10 and an attaching arrangement 26 for attaching the connecting device 10 to the support. The securing arrangement 25 can be any suitable securing arrangement, and one example is described below in more detail.

[0035] The attaching arrangement 26 comprises an attaching member 27 having a first projecting portion 28 with an upper surface 28A. The attaching arrangement 26 further includes a threaded fastening element 30 (see Figures 6, 9 and 10) extending from the upper surface 28A of the first projecting portion 28 into the securing arrangement 25.

[0036] The threaded fastening element 30 is screwed into a correspondingly threaded recess 31 in the securing arrangement 25, thereby fastening the securing arrangement 25 to the attaching member 27.

[0037] The first projecting portion 28 has a length L (see Figure 1) which is greater than the width A of the slots 22 in the support 14. Thus, the first projecting portion projects beyond the

opposite edges of the slot 22 when the attaching member 27 is in its attaching position, as explained below.

[0038] The attaching member 27 further includes a second projecting portion 32 and a spacer portion 34 between the first and second projecting portions 28, 32, whereby a gap 36 is defined between the first and second projecting portions 28, 32 on each side of the spacer portion 34. The size of each gap 36 is substantially equal to, or greater than, the thickness of the central strip 18 and the transverse strips 20, thereby allowing regions of the support 14 to be received in the gap 36.

[0039] The second projecting portion 32 has a substantially rectangular shape, and projects from the spacer portion 34 on opposite sides thereof across the first projecting portion 28. The second projecting portion 32 has a width B (see Figure 2) that is less than the width A of the elongate slots 22 in the support 14, and a length C (see Figure 1) that is greater than the width A of the elongate slots 22 in the support 14.

[0040] The attaching member 27 further includes upstanding lugs 38 on the upper surface 28A of the first projecting portion 28. The purpose of the lugs 38 is explained below.

[0041] The attaching arrangement 26 further includes a locking arrangement 40 (see Figures 7 and 8) for locking the connecting device 10 to the support 14. The locking arrangement 40 comprises a detent formation 42 and a release tab 44 for releasing the locking arrangement 40 from the support 14. The detent formation 42 is in the form of a V shaped resilient member. When the connecting arrangement 10 is in the attaching position in one of the openings 22, the detent formation 42 is received in the same opening 22.

[0042] The detent formation 42 comprises opposite arms 48, 50 forming the V. One of the arms 48 is attached to a mounting member 52. The other arm 50 is attached to the release tab 44. The mounting member 52 is provided to mount the locking arrangement 40 on the attaching arrangement 26.

[0043] The mounting member 52 is substantially flat and defines a substantially oval main aperture 54 through which the fastening element 30 on the attaching arrangement 26 is received. The mounting member also defines a pair of opposite subsidiary apertures 56 to receive the lugs 38, thereby locating the mounting member on the first projecting portion 28 when the fastening element 30 is received in the main aperture 54. Thus, when the fastening element 30 is screwed into the threaded recess 31 to fasten the attaching arrangement 26 to the securing arrangement, the mounting member 52 is held between the securing arrangement 25 and the attaching arrangement 26. This securely mounts the locking arrangement 40 on the attaching arrangement 26.

[0044] In use, the attaching arrangement 26 is inserted into one of the elongate slots 22, for example, in one of the transverse strips 20 of the support 14, so that the first and second projecting portions 28, 32 are disposed on opposite sides of the transverse strip 20 (see

Figures 4A and 5A). In this position, the spacer portion 34 extends through the slot 22, and the second projecting portion 32 extends parallel to the elongate slot 22, as shown in figure 4A and 5A. In this position, the detent formation 42 of the locking arrangement 40 engages the top surface of the transverse strip 20, and the arm 48 is deformed upwardly, as shown in Figure 5A.

[0045] The securing device 25 is rotated about the axis of rotation R in the direction indicated by the arrow 29 to an attaching position (see Figures 4C and 5C). The securing arrangement 25 is fixedly mounted on the attaching arrangement 26 by the fastening element 30. Thus, rotating the securing device 25 about the axis R also rotates the attaching arrangement 26 in the same direction to the attaching position. In the attaching position, the second projecting portion 32 is disposed across the slot 22 and projects beyond the edges of the slot 22.

[0046] When the connecting device 10 is rotated as described above, the second projecting portion 32 is moved to a position in which it extends at right angles to the elongate slot 22, as shown in Figures 4C and 5C. During the rotation of the connecting device 10, the detent formation 42 is moved to the position shown in Figures 4C and 5C, in which it is received in the slot 22.

[0047] In the position shown in Figures 4C and 5C, the detent formation 42 moves to a non-deformed position as the detent formation 42 is received in the slot 22. The non-deformed position of the detent formation 42 is shown in Figure 2. The connecting device 10 is prevented from further rotation by the detent formation engaging the edges of the slot 22, thereby preventing inadvertent release of the attaching arrangement 26 from the support 14.

[0048] If it is desired to release the attaching arrangement 26 from the slot 22, the user can engage the tab 44 and move the detent formation 42 to its deformed position shown in Figure 5A, thereby removing the detent formation 42 from the slot 22. The connecting device 10 can then be rotated to remove the attaching arrangement 26 from the slot 22.

[0049] Figure 11 is a sectional view of the connecting device 10, showing an example of the securing arrangement 25 in more detail. The securing arrangement 25 comprises a body 60 defining a first through bore 62. The attaching member 27 defines a second through bore 64 aligned with the first through bore 62 when the attaching arrangement 27 is fastened to the securing arrangement 25, as shown in Figure 11.

[0050] The securing device 25 further includes clamping mechanism comprising a carriage 66 carrying a plurality of clamping members in the form of balls 68. The body further includes a shoulder 70 extending around the first through bore 62. The clamping mechanism includes a spring 72 extends from the shoulder to the carriage to urge the carriage in the direction indicated by the arrow 74. The first through bore 62 tapers inwardly at a tapering region 76. Thus, the urging of the carriage in the direction indicated by the arrow 74 urges the balls 68 towards each other.

[0051] A cable 80 can be inserted through the first through bore 62 in the direction opposite to the arrow 74. The cable 80 engages the balls 68 and pushes the carriage 66 also in the direction opposite to the arrow 74, thereby moving the balls 68 away from each other. Eventually, the carriage reaches a position at which the cable 80 can be pushed past the balls 68 and threaded through the first through bore 62 and through the second through bore 64. Pulling the cable 80 in the direction of the arrow 74 causes the carriage 66 to be urged in the direction of the arrow 74, thereby causing the balls 68 to be urged inwardly towards each other to clamp the cable 80. The cable 80 is thus secured to the securing arrangement 25.

[0052] The carriage 66 includes a button portion 76 which can be pressed inwardly in the direction opposite to the arrow 74, thereby moving the carriage 66 in the direction opposite to the arrow 74. This releases the balls 68 from the cable 80 and allows the position of the cable 80 within the securing arrangement 25 to be adjusted.

[0053] The cable 80 can be attached to a suitable securing point in the roof of a building to suspend the connecting device and the support 14 attached to the attaching arrangement 26.

[0054] A clamping mechanism similar to the mechanism described above is disclosed in patent specification No. US 5417400 A.

[0055] Figure 12 shows an example of a support 14 suspended by two cables 80. The cables 80 could be attached at their upper ends to appropriate securing points (not shown) in the roof of a building.

[0056] The lower end regions of the cables 80 are secured to securing arrangements 25 of respective connecting devices 10 in the manner described above. Each of the connecting devices 10 is attached to the support 14. The second projecting portions 32 of each attaching arrangement 26 are received through a respective one of the slots 22, and the detent formations 42 are received in the slots 22, thereby locking the connecting devices 10 to the support 14 in the positions shown in Figure 12.

[0057] Pipework or other suitable apparatus can then be attached to the support 14.

[0058] There is thus described a connecting device 10 having an attaching arrangement 26 that can be attached to a support 14 and suspended from a roof of a building, the connecting device 10 being locked in attachment to the support 14 by a locking arrangement 26.

REFERENCES CITED IN THE DESCRIPTION

Cited references

This list of references cited by the applicant is for the reader's convenience only. It does not form part of the European patent document. Even though great care has been taken in compiling the references, errors or omissions cannot be excluded and the EPO disclaims all liability in this regard.

Patent documents cited in the description

- FR2846398 [0002]
- US5417400A [0054]

PATENTKRAV

1. Fastgørelsesanordning (26) til fastgørelse af en forbindelsesindretning (10) til en første genstand (14), hvilken fastgørelsesanordning (26) omfatter:

et fastgørelseselement (27), der kan modtages gennem en åbning i den første genstand (14); og

en låseanordning (40) til fastlåsning af forbindelsesindretningen (10) til den første genstand (14), hvilken låseanordning (40) omfatter en palformation (42), der er konfigureret til at blive modtaget af åbningen i den første genstand (14);

10 hvor palformationen (42) omfatter et elastisk element, idet det elastiske element kan modtages i åbningen i den første genstand (14), og det elastiske element i det væsentlige er V-formet og har modstående arme (48, 50), der danner V'et;

kendetegnet ved, at låseanordningen (40) indbefatter et monteringselement (52) til montering af låseanordningen (40) på fastgørelsesanordningen (26), idet monteringselementet (52) er fastgjort til den ene af armene (48);

hvor fastgørelsesanordningen (26) har et fastgørelseselement (30) til fastgørelse af fastgørelsesanordningen (26) til en sikringsanordning (25), og monteringselementet (52) definerer en åbning (54), gennem hvilken fastgørelseselementet (30) strækker sig, til montering af låseanordningen (40) på fastgørelsesanordningen (26); og

hvor låseanordningen (40) yderligere indbefatter en frigivelseslask (44), der er fastgjort til den anden af armene (50), med henblik på at lette armenes (48, 50) bevægelse hen imod hinanden.

2. Fastgørelsesanordning (26) ifølge krav 1, hvor armen (48), der er fastgjort til monteringselementet (52), kan bevæges fra en elastisk deformeret position til en ikke-deformeret position, når fastgørelsesanordningen (26) bevæges til fastgørelsespositionen, idet armens (48) bevægelse fra den deformerede position

til en ikke-deformeret position er en bevægelse af det elastiske element fra en deformeret position til en ikke-deformeret position.

3. Fastgørelsesanordning (26) ifølge krav 1 eller 2, hvor fastgørelseselementet (27) omfatter en første fremspringende del (28) til indgreb med den første genstand (14) og en anden fremspringende del (32) til indføring gennem den første genstand (14), hvorved et område af den første genstand (14), når den anden fremspringende del (32) indføres gennem den første genstand (14), kan modtages mellem den første og den anden fremspringende del (28, 32), hvilket derved fastgør forbindelsesindretningen (10) til den første genstand (14).
- 10 4. Fastgørelsesanordning (26) ifølge krav 3, hvor fastgørelseselementet (30) strækker sig mellem den første fremspringende del (28) og sikringsanordningen (25), idet den første fremspringende del (28) går i indgreb med en første flade af området af den første genstand (14), og den anden fremspringende del (32) går i indgreb med en modstående anden flade af området af den første genstand (14).
- 15 5. Fastgørelsesanordning (26) ifølge et hvilket som helst af kravene 3 eller 4, hvor fastgørelsesanordningen (26) har en rotationsakse (R), der strækker sig gennem den første og den anden fremspringende del (28, 32), idet fastgørelsesanordningen (26) kan rotere omkring akslen til en fastgørelsesposition med henblik på at fastgøre forbindelsesindretningen (10) til den første genstand
20 (14), hvorved palformationen (42) modtages i åbningen, når fastgørelsesanordningen (26) roteres omkring rotationsaksen (R), og når fastgørelsesanordningen (26) roteres således, kan et område af den første genstand (14) modtages mellem den første og den anden fremspringende del (28, 32).
- 25 6. Fastgørelsesanordning (26) ifølge krav 5, hvor den anden fremspringende del (32) har en forreste flade og et sikringsområde, idet den forreste flade er det første område af den anden fremspringende del (32), med henblik på at forløbe hen over det ovennævnte område af den første genstand (14), når fastgørelsesanordningen (26) roteres til fastgørelsespositionen; og hvor den
30 anden fremspringende del (32) har en fastgørelsesflade med henblik på at gå i

indgreb med den første genstand (14), når fastgørelsesanordningen (26) er i fastgørelsespositionen.

7. Fastgørelsesanordning (26) ifølge krav 6, hvor fastgørelseselementet (27) yderligere indbefatter en afstandsstykkedel (34), der strækker sig mellem den første og den anden fremspringende del (28, 32), og der er defineret en spalte (36) mellem den første og den anden fremspringende del (28, 32), idet spalten (36) er større ved den forreste flade end ved fastgørelsesfladen, hvor den forreste flade tilspidises til fastgørelsesfladen.

8. Fastgørelsesanordning (26) ifølge krav 7, hvor den første og den anden fremspringende del (28, 32) strækker sig udadtil fra fastgørelseselementet (30), idet den anden fremspringende del (32) strækker sig fra afstandsstykkedelen (34) i modstående retninger i forhold dertil.

9. Fastgørelsesanordning (26) ifølge krav 8, hvor den første fremspringende del (28) strækker sig radialt fra fastgørelseselementet (30) og i det væsentlige er cirkulær, og hvor den anden fremspringende del (32) i det væsentlige er rektangulær med en bredde, der er større end længden.

10. Fastgørelsesanordning (26) ifølge et hvilket som helst af kravene 7 til 9, hvor afstandsstykkedelen (34) har en anslagsformation med henblik på at forhindre rotation af fastgørelsesanordningen (26) i den ene retning.

11. Fastgørelsesanordning (26) ifølge krav 10, hvor anslagsformationen omfatter diagonalt modstående områder af afstandsstykkedelen (34), idet afstanden mellem områderne er større end åbningens bredde.

12. Fastgørelsesanordning (26) ifølge et hvilket som helst af kravene 7 til 11, hvor afstandsstykkedelen (34) har en krum kant med henblik på at muliggøre rotation af fastgørelsesanordningen (26) i forhold til den første genstand (14), og afstandsstykkedelen (34) har diametralt modsatte krumme kanter, hvor den diametrale afstand mellem de krumme kanter er mindre end bredden af åbningen i den første genstand (14).

13. Forbindelsesindretning (10) til forbindelse af en første genstand (14) til en langstrakt anden genstand (24), idet forbindelsesindretningen (10) omfatter: en

sikringsanordning (25) til sikring af indretningen til den langstrakte anden genstand (24); og en fastgørelsesanordning (26) ifølge et hvilket som helst af kravene 1 til 12.

14. Forbindelsesanordning (12), der omfatter: en forbindelsesindretning (10) og en første genstand (14), idet forbindelsesindretningen (10) omfatter en sikringsanordning (25) til sikring af forbindelsesindretningen (10) til en langstrakt anden genstand (24); og en fastgørelsesanordning (26) ifølge et hvilket som helst af kravene 1 til 12.

15. Fremgangsmåde til forbindelse af en første genstand (14) til en langstrakt anden genstand (24), hvilken fremgangsmåde omfatter tilvejebringelse af en forbindelsesanordning (12) ifølge krav 14, indføring af fastgørelsesanordningen (26) gennem en åbning i den første genstand (14) og anbringelse af palformationen (42) i åbningen i den første genstand (14) med henblik på at fastlåse forbindelsesindretningen (10) til den første genstand (14), hvor fremgangsmåden omfatter manipulering af lasken (44) med henblik på at bevæge armen (50), der er fastgjort dertil, fra en ikke-deformeret position til en deformeret position til frigivelse af det elastiske element fra åbningen, i hvilken det elastiske element modtages.

DRAWINGS

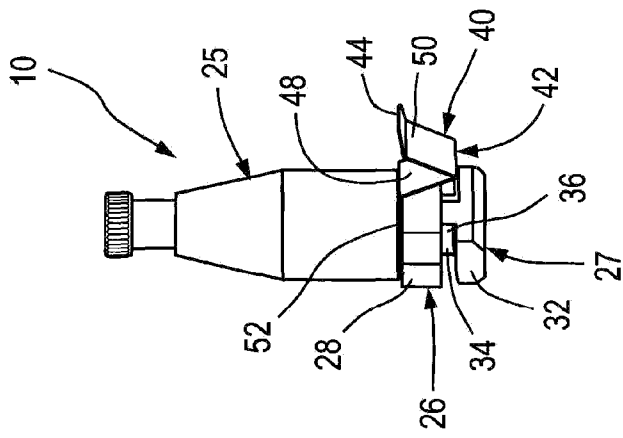

Fig. 1

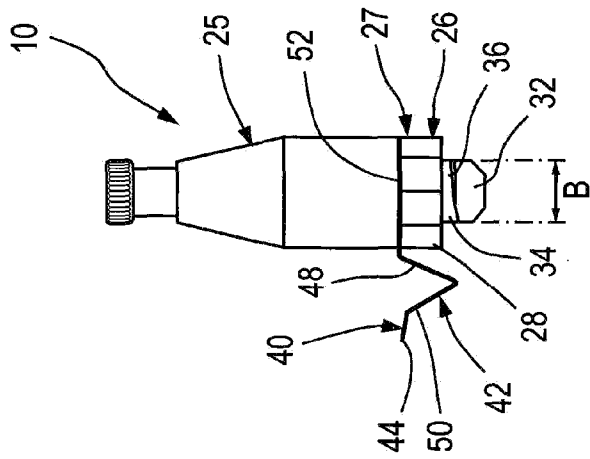

Fig. 2

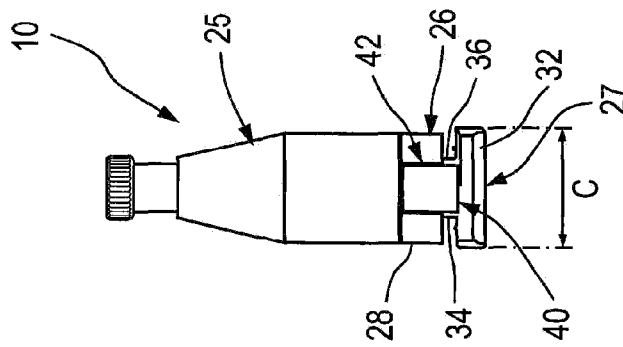

Fig. 3

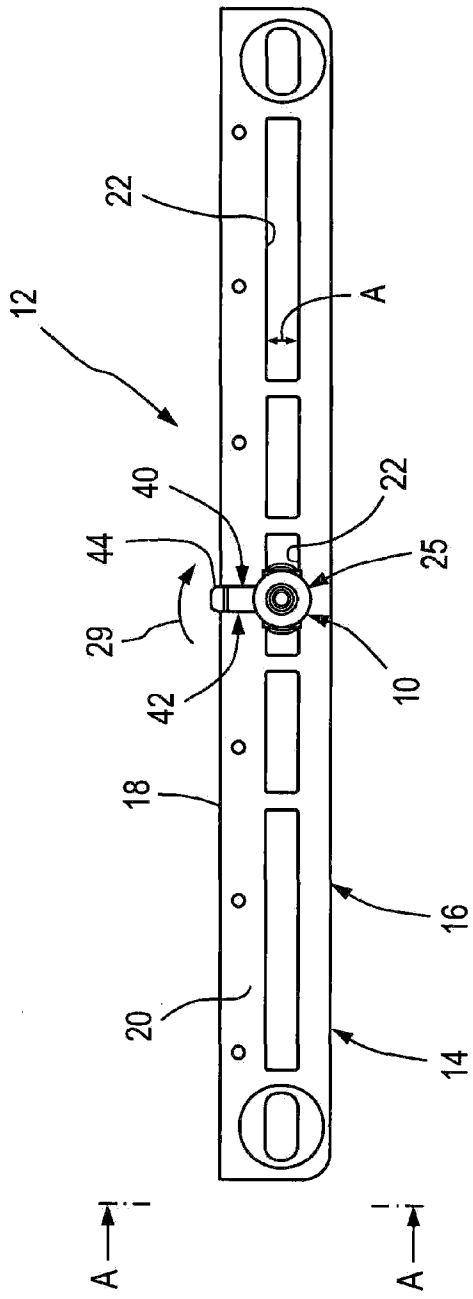

Fig. 4A

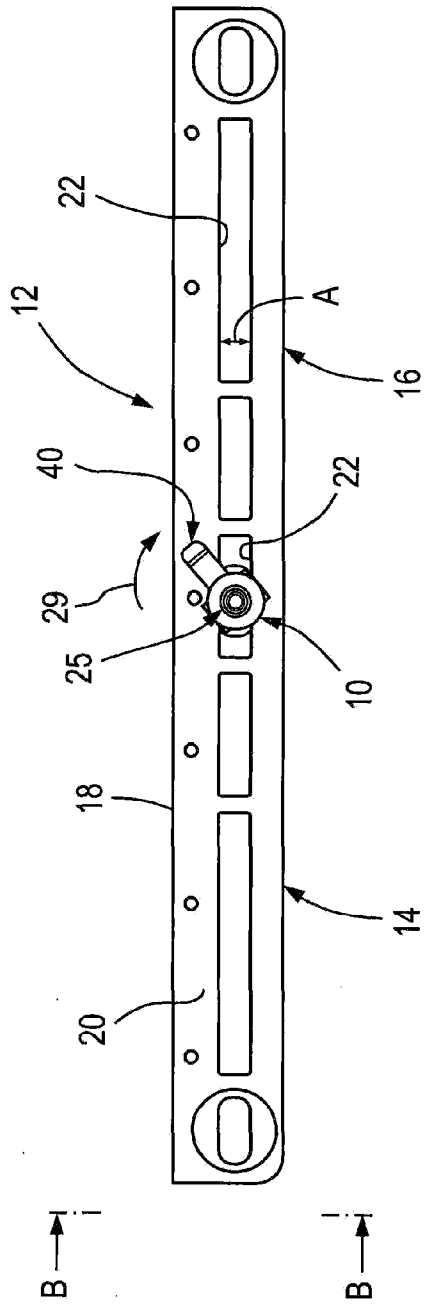

Fig. 4B

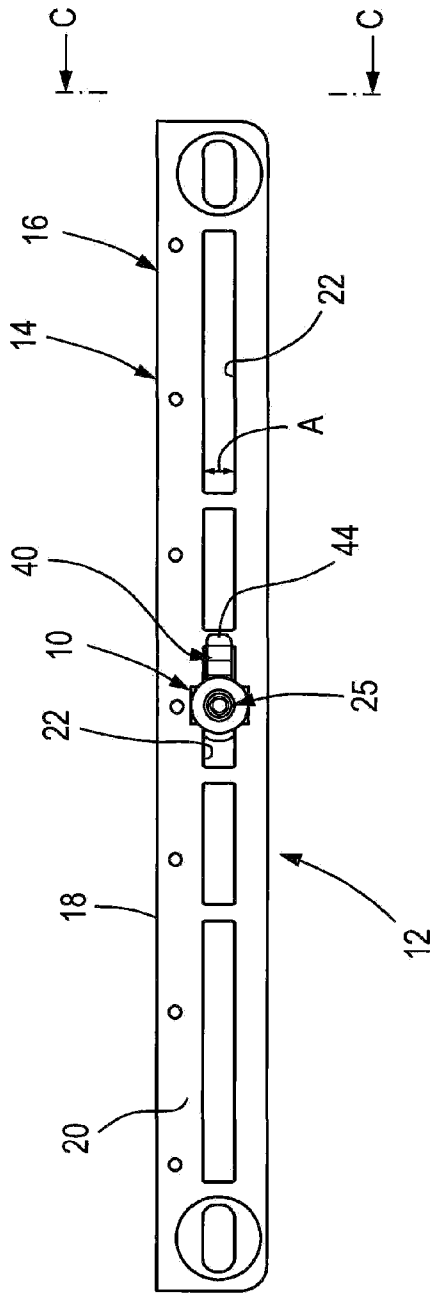

Fig. 4C

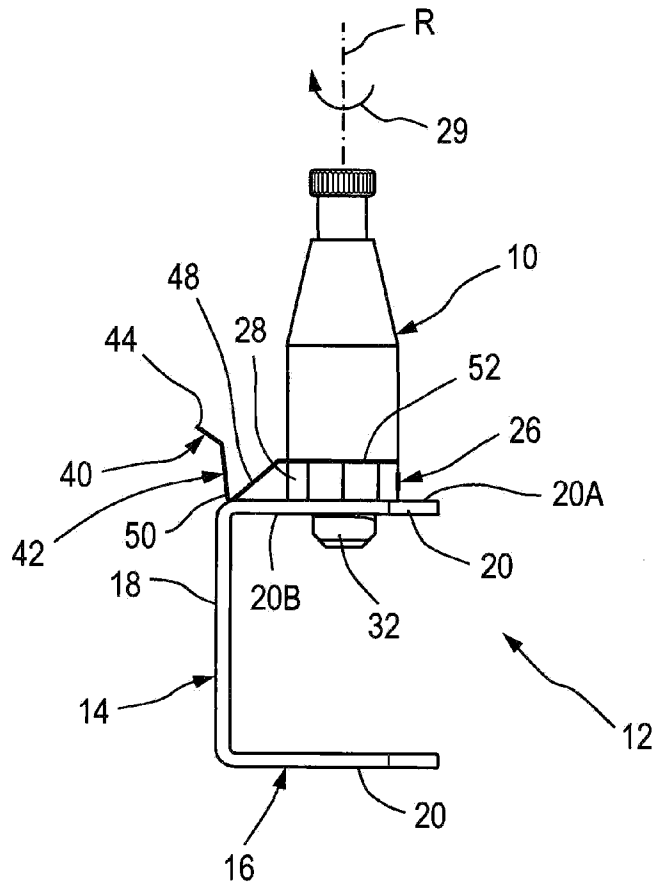

Fig. 5A

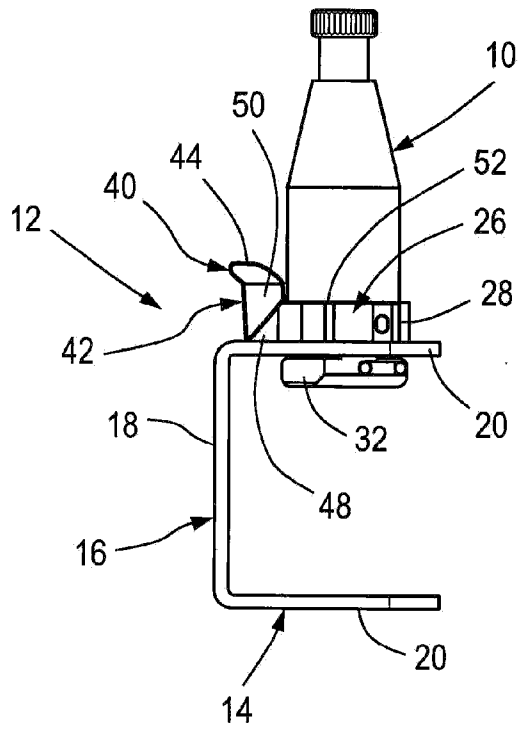

Fig. 5B

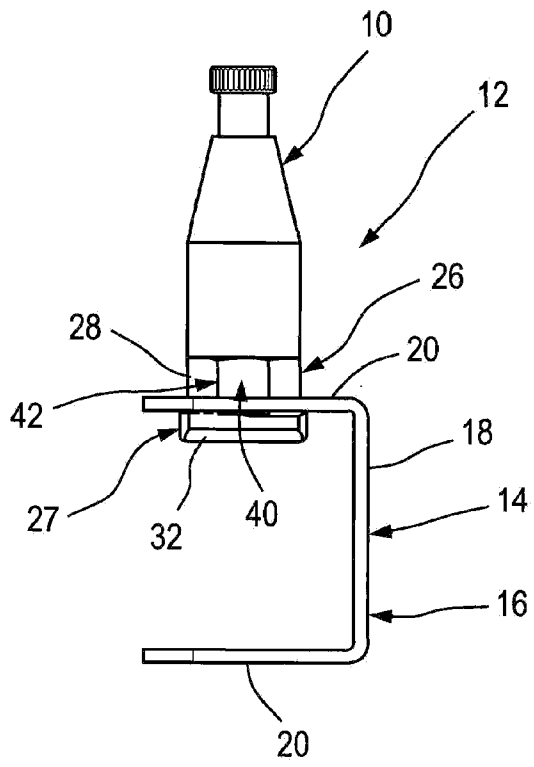

Fig. 5C

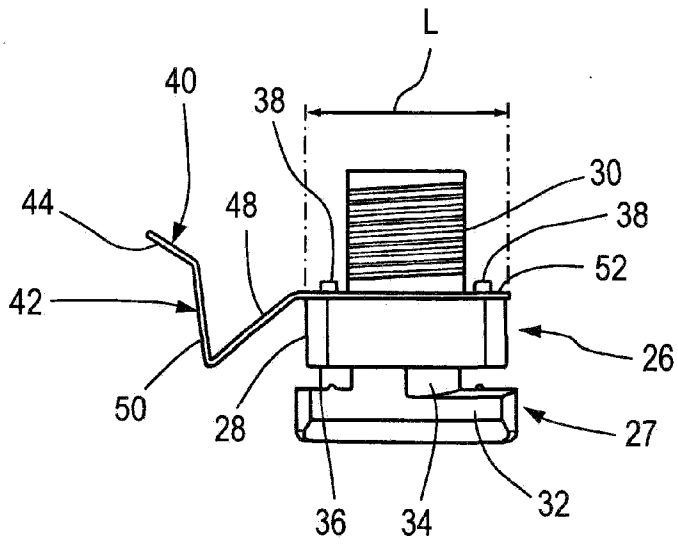

Fig. 6

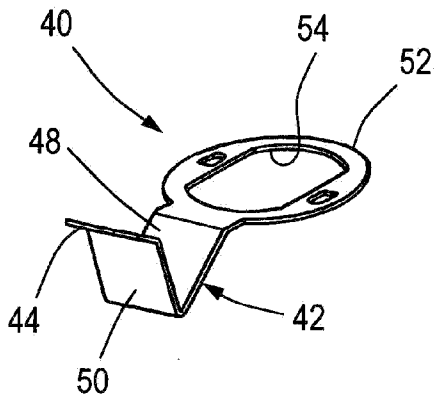

Fig. 7

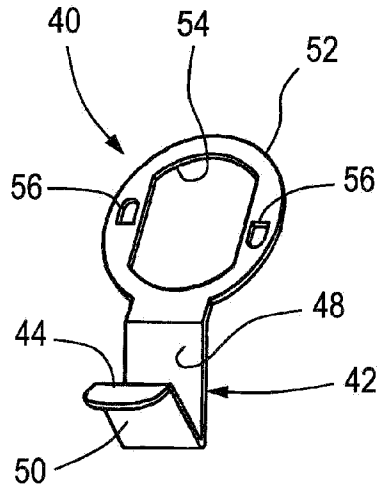

Fig. 8

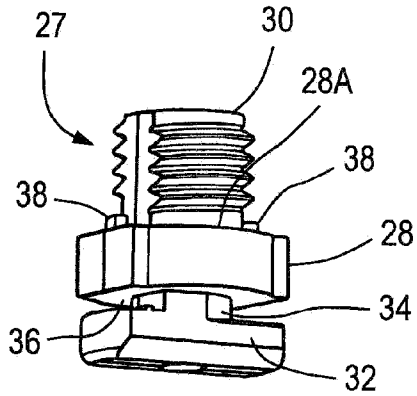

Fig. 9

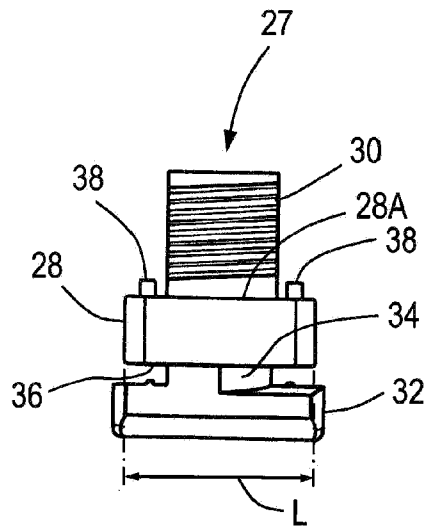

Fig. 10

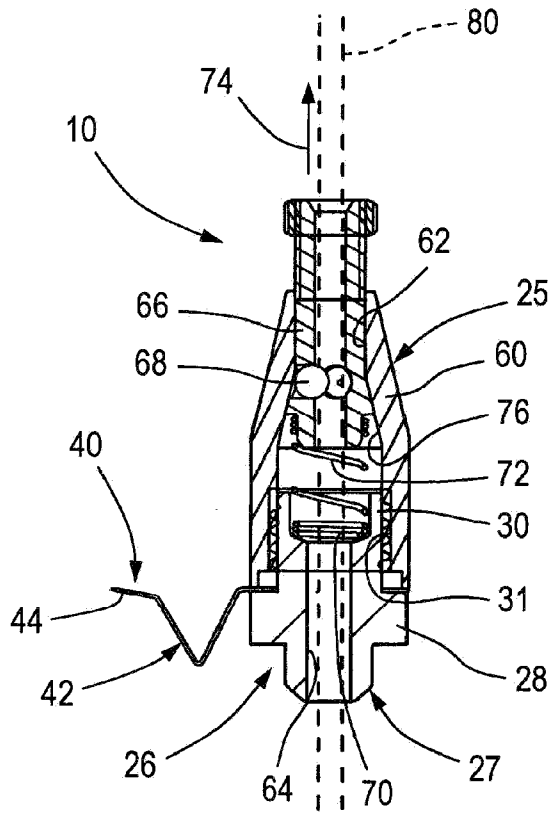

Fig. 11

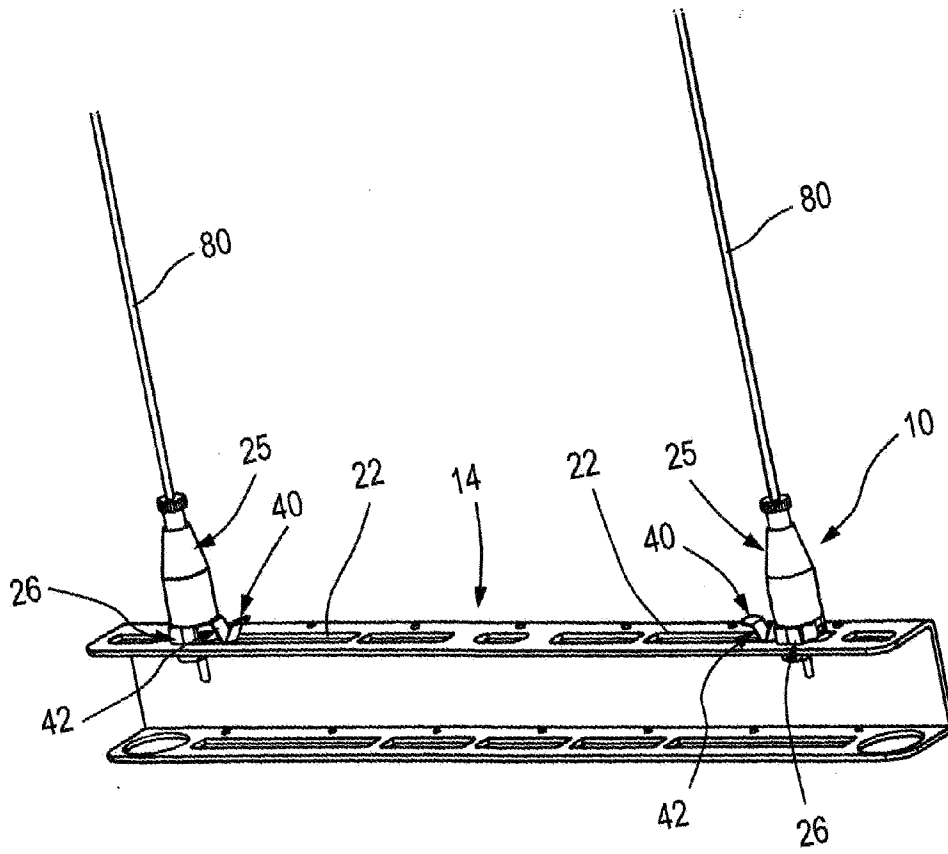

Fig. 12