

F. H. JURY.
Vehicle-Top.

No. 168,902.

Patented Oct. 19, 1875.

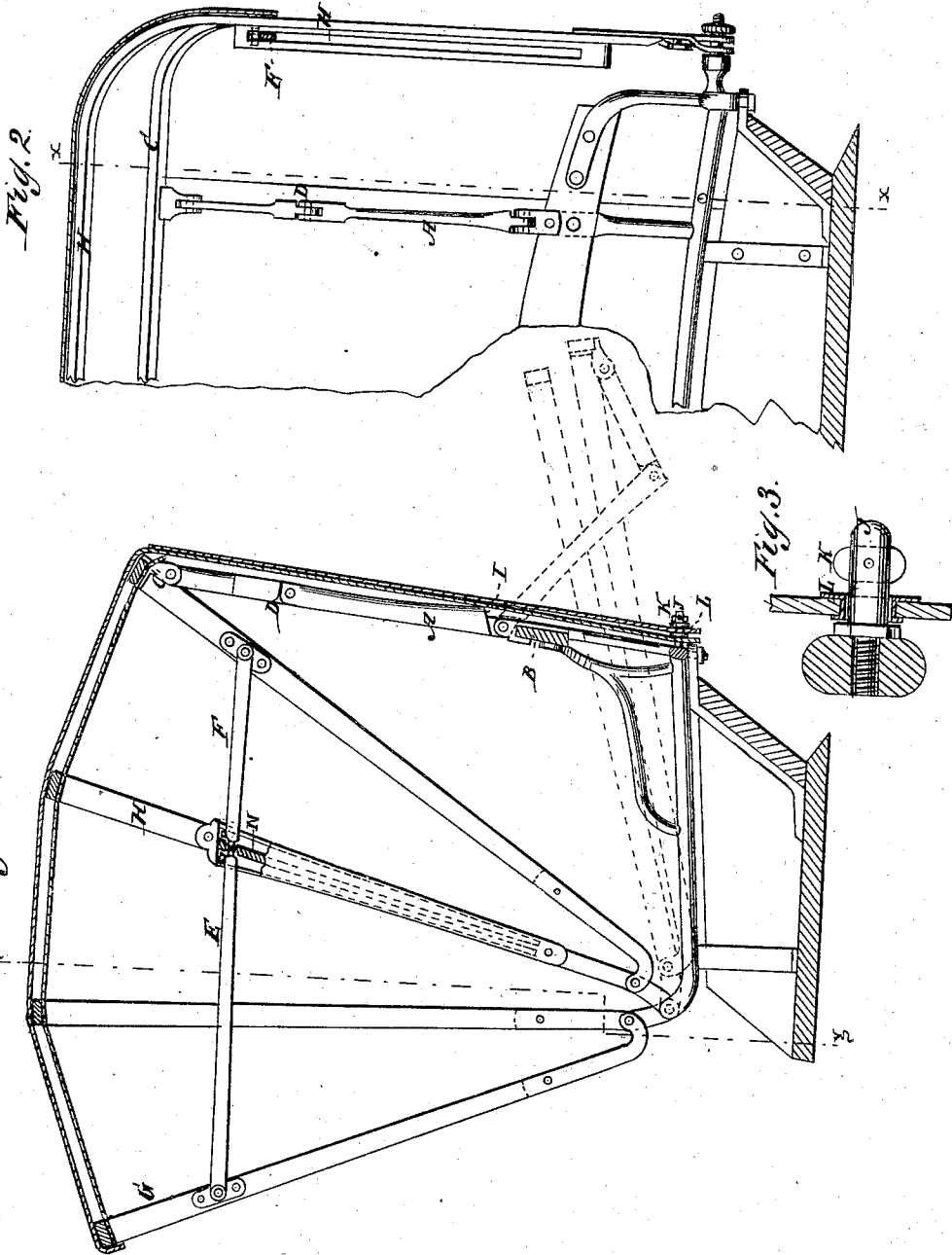

WITNESSES:

E. Mott
A. J. Terry

INVENTOR:
F. H. Jury
BY
Munnell
ATTORNEYS.

UNITED STATES PATENT OFFICE.

FREDRICH H. JURY, OF NEW YORK, N. Y.

IMPROVEMENT IN VEHICLE-TOPS.

Specification forming part of Letters Patent No. **168,902**, dated October 19, 1875; application filed June 12, 1875.

To all whom it may concern:

Be it known that I, FREDRICH H. JURY, of the city, county, and State of New York, have invented a new and Improved Carriage-Top, of which the following is a specification:

The invention is an improvement in the class of carriage-tops in which outside braces are dispensed with.

My improvement in braces consists of a pair of jointed standards, made each in two parts, which are hinged together and to the seat-back and back bow.

Figure 1 is a sectional elevation of my improved top, taken on the line *xx* of Fig. 2. Fig. 2 is a section on the line *yy* of Fig. 1; and Fig. 3 is a detail section, showing the curtain-fastening.

Similar letters of reference indicate corresponding parts.

A represents the standards on the top of the back of the seat B, and connected to the back bow C, said standards being jointed to the seat-back and the bow, and having a rule-joint at D, which folds backward but not forward. E and F represent the stays connecting the back bow C and the front bow G with one of the middle bows H, to spread out and hold the top in an extended condition, and being coupled to bow H, so as to fold by sliding down it when the top is to be folded, said stays being arranged inside of the bows, where they can be handled easily by the occupant of the seat, and the standards are inside of the back curtain, so that the unsightly projections of the common arrangement on the outside, and the necessary holes for them in the cover, are avoided, making a neater and more durable contrivance. The stays E F spring into indented cavities in the spring N, to be held up,

as in Fig. 1, for spreading the top. The standards have a prop, stud, or shoulder, I, which rests on the top of the seat-back when the bows are folded down, and supports the standard in such position that it supports the bows, as indicated by the dotted lines in Fig. 1, the standards being entirely under the back portion of the top, out of sight, and making a neater and better arrangement than the projecting folded braces of the common arrangement. J represents the stud; K, the pivoted T-head in the stud; and L the grommet in the curtain, constituting the fastening which I propose to use.

I am aware of the employment of jointed standards or braces, so connected with the back of a carriage and the back bow of its top as to perform the same function as mine; but their arrangement is quite different, so that they are inoperative without adjunctive devices.

Having thus described my invention, I claim as new and desire to secure by Letters Patent—

1. The combination, with seat-back B and back bow C, of pivoted standards A, made each in two parts, and connected by the rule-joint, as shown and described, whereby said standards are made self-sustaining when the top is extended or raised, and will fold backward to secure the top when lowered, as set forth.

2. The prop-stud I of standard A, arranged in combination with the seat-back B to enable the standard to prop the bows when folded down, substantially as specified.

FREDRICH H. JURY.

Witnesses:

T. B. MOSHER,
ALEX. F. ROBERTS.