

(19) World Intellectual Property  
Organization  
International Bureau



(43) International Publication Date  
4 November 2004 (04.11.2004)

PCT

(10) International Publication Number  
**WO 2004/094822 A2**

- (51) International Patent Classification<sup>7</sup>: **F04B**
- (21) International Application Number:  
PCT/US2004/012111
- (22) International Filing Date: 19 April 2004 (19.04.2004)
- (25) Filing Language: English
- (26) Publication Language: English
- (30) Priority Data:  
60/464,466 22 April 2003 (22.04.2003) US

TR), OAPI (BF, BJ, CF, CG, CI, CM, GA, GN, GQ, GW, ML, MR, NE, SN, TD, TG).

**Declarations under Rule 4.17:**

— as to applicant's entitlement to apply for and be granted a patent (Rule 4.17(ii)) for the following designations AE, AG, AL, AM, AT, AU, AZ, BA, BB, BG, BR, BW, BY, BZ, CA, CH, CN, CO, CR, CU, CZ, DE, DK, DM, DZ, EC, EE, EG, ES, FI, GB, GD, GE, GH, GM, HR, HU, ID, IL, IN, IS, JP, KE, KG, KP, KR, KZ, LC, LK, LR, LS, LT, LU, LV, MA, MD, MG, MK, MN, MW, MX, MZ, NA, NI, NO, NZ, OM, PG, PH, PL, PT, RO, RU, SC, SD, SE, SG, SK, SL, SY, TJ, TM, TN, TR, TT, TZ, UA, UG, UZ, VC, VN, YU, ZA, ZM, ZW, ARIPO patent (BW, GH, GM, KE, LS, MW, MZ, SD, SL, SZ, TZ, UG, ZM, ZW), Eurasian patent (AM, AZ, BY, KG, KZ, MD, RU, TJ, TM), European patent (AT, BE, BG, CH, CY, CZ, DE, DK, EE, ES, FI, FR, GB, GR, HU, IE, IT, LU, MC, NL, PL, PT, RO, SE, SI, SK, TR), OAPI patent (BF, BJ, CF, CG, CI, CM, GA, GN, GQ, GW, ML, MR, NE, SN, TD, TG)

- (71) Applicant (for all designated States except US): **R. CONRADER COMPANY** [US/US]; 1702 Wagner Avenue, P.O. Box 924, Erie, PA 16512 (US).
- (72) Inventor; and
- (75) Inventor/Applicant (for US only): **CORNWELL, James, P.** [US/US]; 8710 Ennis Drive, Erie, PA 16509 (US).
- (74) Agents: **WOODARD, Jon, L.** et al.; McDonald, Illig, Jones and Britton LLP, 100 State Street- Suite 700, Erie, PA 16507-1459 (US).

— as to the applicant's entitlement to claim the priority of the earlier application (Rule 4.17(iii)) for the following designations AE, AG, AL, AM, AT, AU, AZ, BA, BB, BG, BR, BW, BY, BZ, CA, CH, CN, CO, CR, CU, CZ, DE, DK, DM, DZ, EC, EE, EG, ES, FI, GB, GD, GE, GH, GM, HR, HU, ID, IL, IN, IS, JP, KE, KG, KP, KR, KZ, LC, LK, LR, LS, LT, LU, LV, MA, MD, MG, MK, MN, MW, MX, MZ, NA, NI, NO, NZ, OM, PG, PH, PL, PT, RO, RU, SC, SD, SE, SG, SK, SL, SY, TJ, TM, TN, TR, TT, TZ, UA, UG, UZ, VC, VN, YU, ZA, ZM, ZW, ARIPO patent (BW, GH, GM, KE, LS, MW, MZ, SD, SL, SZ, TZ, UG, ZM, ZW), Eurasian patent (AM, AZ, BY, KG, KZ, MD, RU, TJ, TM), European patent (AT, BE, BG, CH, CY, CZ, DE, DK, EE, ES, FI, FR, GB, GR, HU, IE, IT, LU, MC, NL, PL, PT, RO, SE, SI, SK, TR), OAPI patent (BF, BJ, CF, CG, CI, CM, GA, GN, GQ, GW, ML, MR, NE, SN, TD, TG)

— of inventorship (Rule 4.17(iv)) for US only

- (81) Designated States (unless otherwise indicated, for every kind of national protection available): AE, AG, AL, AM, AT, AU, AZ, BA, BB, BG, BR, BW, BY, BZ, CA, CH, CN, CO, CR, CU, CZ, DE, DK, DM, DZ, EC, EE, EG, ES, FI, GB, GD, GE, GH, GM, HR, HU, ID, IL, IN, IS, JP, KE, KG, KP, KR, KZ, LC, LK, LR, LS, LT, LU, LV, MA, MD, MG, MK, MN, MW, MX, MZ, NA, NI, NO, NZ, OM, PG, PH, PL, PT, RO, RU, SC, SD, SE, SG, SK, SL, SY, TJ, TM, TN, TR, TT, TZ, UA, UG, US, UZ, VC, VN, YU, ZA, ZM, ZW.

**Published:**

— without international search report and to be republished upon receipt of that report

- (84) Designated States (unless otherwise indicated, for every kind of regional protection available): ARIPO (BW, GH, GM, KE, LS, MW, MZ, SD, SL, SZ, TZ, UG, ZM, ZW), Eurasian (AM, AZ, BY, KG, KZ, MD, RU, TJ, TM), European (AT, BE, BG, CH, CY, CZ, DE, DK, EE, ES, FI, FR, GB, GR, HU, IE, IT, LU, MC, NL, PL, PT, RO, SE, SI, SK,

For two-letter codes and other abbreviations, refer to the "Guidance Notes on Codes and Abbreviations" appearing at the beginning of each regular issue of the PCT Gazette.

(54) Title: AIR COMPRESSOR WITH INLET CONTROL MECHANISM AND AUTOMATIC INLET CONTROL MECHANISM

(57) Abstract: An automatic inlet control mechanism and air compressor unit include a valve cavity and valve outlet. The valve cavity includes a valve control chamber and valve inlet chamber. A valve piston assembly is positioned between the valve control chamber and the valve inlet chamber to prevent the flow of air between therebetween. The valve outlet allows air to flow from the valve inlet chamber into the compressor unit. The valve piston assembly prevents air from flowing from the valve inlet chamber to the valve outlet when the compressor unit is not drawing air. A vent passageway allows air to flow between the valve control chamber and the compression cylinder inlet when compression is begun at the start-up of the compressor unit or at the loading of the idling compressor unit. A vent orifice restricts the flow of air from the valve control chamber to the compression cylinder inlet.

WO 2004/094822 A2

## **Air Compressor With Inlet Control Mechanism and Automatic Inlet Control Mechanism**

This application takes priority from U. S. provisional application 60/464,466 filed April 22, 2003, which is incorporated herein by reference.

### **Background**

Portable reciprocating air compressor units are commonly used in a variety of applications to produce pneumatic pressure from mechanical energy that is generated from a conventional energy source such as gasoline or electricity. Such an air compressor unit normally includes a compressor pump having a reciprocating piston located within a compression cylinder, a power plant such as a motor or engine that supplies mechanical energy to the piston to cause it to reciprocate and an air reservoir for storing compressed air. The compression cylinder is configured to draw air from the environment surrounding the compressor unit and to compress the drawn air that is discharged into an air reservoir, creating a supply of air pressure having a predeterminable magnitude. A motor, engine, or other power plant is normally connected to the compressor pump to drive the reciprocating piston within a compression cylinder.

During operation of the compressor unit, a rotating crankshaft, flywheel, or other assembly connected to the reciprocating piston stores a sufficient amount of angular momentum to substantially reduce the amount of high speed torque that must be exerted by the power plant to cause the piston to reciprocate. This allows the compressor pump to devote more of the total torque output of the power plant to drawing air into the compression cylinder, compressing the air and discharging the air into the air reservoir.

However, prior to operation, the crankshaft does not rotate and therefore has no angular momentum. The power plant must therefore contend with a substantially increased low speed torque requirement to overcome the combined inertial and compression loaded resistance of the piston and other components of the compressor pump until operating speed is achieved. This increased low speed torque requirement can result in adverse system effects on the power plant such as stalling, overloading, or premature wear. It can also require that a larger or more

sophisticated power plant be used to overcome the initial starting torque of the compressor unit, even if such a power plant is not actually needed to sustain reciprocation of the piston after the compressor has attained an operating speed. It follows that if the compression loaded resistance of the piston can be reduced prior to the compressor pump reaching its full operating speed, it becomes possible for the power plant to devote more total torque output to overcoming inertial resistance. This in turn can minimize the adverse effects of combined inertial and compression loading, can allow for the use of a smaller or less powerful and/or less sophisticated power plant or starting system, and can therefore lead to substantial reductions in energy usage by the compressor unit.

### **Summary**

The invention is an automatic inlet control mechanism and an air compressor unit having both a piston reciprocating within a compression cylinder and a compression cylinder inlet for which the automatic inlet control mechanism is a component. The air compressor unit includes a power plant such as a motor or engine to reciprocate the piston and an air reservoir to store compressed air. The control mechanism itself includes a mechanism body having a valve inlet, a valve cavity and a valve outlet. The valve cavity is divided into a valve control chamber and a valve inlet chamber. A valve piston assembly is positioned between the valve control chamber and the valve inlet chamber and is constructed to prevent the flow of air between the two chambers. The valve inlet allows air to flow from the atmosphere surrounding the compressor unit into the valve inlet chamber. The valve outlet allows air to flow from the valve inlet chamber to the compression cylinder inlet and has a size that allows a sufficient amount of air to flow into the compressor unit to allow the compressor unit to produce compressed air at a predetermined rate of production.

The valve piston assembly includes a valve piston that is configured to reciprocate within the valve cavity. In some embodiments, the valve piston assembly includes a diaphragm that is positioned to prevent airflow between the valve control chamber and the valve inlet chamber. A biasing member provides a force that moves the valve piston assembly to a position within the inlet control mechanism that prevents air from flowing from the valve inlet to

the valve outlet when the compressor unit is not drawing air through the valve outlet. This occurs, by way of example, when a compressor unit is shut down or when a continuously running compressor unit is unloaded and is idling.

A vent passageway allows air to flow between the valve control chamber and the compression cylinder inlet when compression is begun at the start-up of a compressor unit or at the loading of an idling compressor unit, as the case may be. The vent passageway is at least one source of air to the compressor cylinder inlet at this time and for a period of time after the compressor unit begins to draw air through the compression cylinder inlet, following the movement of the valve piston assembly to a position which prevents air from flowing from the valve inlet chamber and through the valve outlet to the compression cylinder inlet. A vent orifice restricts the flow of air from the valve control chamber to the compression cylinder inlet. The vent orifice has a size that allows the air to be drawn by the compressor unit from the valve control chamber to the compressor cylinder at a preselected rate which causes the compressor unit to produce compressed air at less than its predetermined rate of production.

The valve control chamber has a volume that enables air to be drawn through the vent orifice into the compression cylinder inlet for a preselected period of time, until the air within the control chamber is at a sufficiently reduced pressure level to allow the valve inlet chamber to overcome the force of the biasing member sufficiently to move the valve piston assembly away from the position at which air is prevented from flowing between the valve inlet chamber and the compression cylinder inlet.

During the preselected period of time, the absence of air flow from the valve inlet chamber to the compression cylinder inlet allows the power plant to dedicate more of its torque output on inertial rather than compression loading. Thus, during this preselected period of time, the compressor unit increases its operating speed without subjecting the full combined load of inertial and compression loading on the power plant. This removal of initial operating torque when compression is started can allow for a substantial reduction in power plant wear or allow for a reduction in the power plant size to that which is necessary to maintain the reciprocation of the piston under load when the compressor has attained its operating speed.

By the time that the compressor unit achieves an operating speed, the valve piston assembly has moved away from a position that prevents air from flowing between the valve inlet chamber and compression cylinder inlet. Air then flows unobstructed from the environment surrounding the compressor into the compression cylinder, allowing the compressor to produce air at its predetermined rate of production.

Those skilled in the art will realize that this invention is capable of embodiments that are different from those shown and that details of the structure of the disclosed inlet control mechanism can be changed in various manners without departing from the scope of this invention. Accordingly, the drawings and descriptions are to be regarded as including such equivalent inlet control mechanisms as do not depart from the spirit and scope of the invention.

#### **Brief Description of the Drawings**

FIG. 1. is a partial cross sectional view of an air compressor unit having an automatic inlet control mechanism according to one embodiment of the invention;

FIG. 2A is a side cross sectional view of the automatic inlet control mechanism of FIG. 1 in a fully closed position;

FIG. 2B is a side cross sectional view of the automatic inlet control mechanism of FIG. 1 in an intermediate position;

FIG. 2C is a side cross sectional view of the automatic inlet control mechanism of FIG. 1 in an open position;

FIG. 3 is an exploded perspective view of the automatic inlet control mechanism of FIGS. 2A-C;

FIG. 4 is a partial cross sectional view of an air compressor unit having an automatic inlet control mechanism according to one embodiment of the invention;

FIG. 5 is a partial cross sectional view of an air compressor unit having an automatic inlet control mechanism according to one embodiment of the invention;

FIG. 6A is a side cross sectional view of the automatic inlet control mechanism according to one embodiment of the invention in a fully closed position;

FIG. 6B is a side cross sectional view of the inlet control mechanism of FIG. 6A in an intermediate position;

FIG. 6C is a side cross sectional view of the inlet control mechanism of FIG. 6A in an open position;

FIG. 7A is a side cross sectional view of an automatic inlet control mechanism according to one embodiment of the invention in a fully closed position;

FIG. 7B is a side cross sectional view of the inlet control mechanism of FIG. 7A in an intermediate position;

FIG. 7C is a side cross sectional view of the inlet control mechanism of FIG. 7A in an open position;

FIG. 8A is a side cross sectional view of an automatic inlet control mechanism according to one embodiment of the invention in a fully closed position;

FIG. 8B is a side cross sectional view of the inlet control mechanism of FIG. 8A in an intermediate position;

FIG. 8C is a side cross sectional view of the inlet control mechanism of FIG. 8A in an open position;

FIG. 9A is a side cross sectional view of an automatic inlet control mechanism according to one embodiment of the invention in a fully closed position;

FIG. 9B is a side cross sectional view of the inlet control mechanism of FIG. 9A in an intermediate position;

FIG. 9C is a side cross sectional view of the inlet control mechanism of FIG. 9A in an open position;

FIG. 10A is a side cross sectional view of an automatic inlet control mechanism according to one embodiment of the invention in a fully closed position;

FIG. 10B is a side cross sectional view of the inlet control mechanism of FIG. 10A in an intermediate position;

FIG. 10C is a side cross sectional view of the inlet control mechanism of FIG. 10A in an open position;

FIG. 11A is a cross sectional view of an automatic inlet control mechanism according to one embodiment of the invention in a closed position;

FIG. 11B is a cross sectional view of the inlet control mechanism of FIG. 11A in an open position;

FIG. 12A is a cross sectional view of an automatic inlet control mechanism according to one embodiment of the invention in a closed position;

FIG. 12B is a cross sectional view of the inlet control mechanism of FIG. 12A in an open position;

FIG. 13A is a cross sectional view of an automatic inlet control mechanism according to one embodiment of the invention in a closed position;

FIG. 13B is a cross sectional view of the inlet control mechanism of FIG. 13A in an open position;

FIG. 14A is a side cross sectional view of an automatic inlet control mechanism according to one embodiment of the invention at a LOW setting;

FIG. 14B is a side cross sectional view of the inlet control mechanism of FIG. 14A at a MEDIUM setting;

FIG. 14C is a side cross sectional view of the inlet control mechanism of FIG. 14A at a HIGH setting;

FIG. 15A is a side cross sectional view of an automatic inlet control mechanism according to one embodiment of the invention at a LOW setting;

FIG. 15B is a side cross sectional view of the inlet control mechanism of FIG. 15A at a MEDIUM setting;

FIG. 15C is a side cross sectional view of the inlet control mechanism of FIG. 15A at a HIGH setting;

FIG. 15D is a magnified view of the inlet control mechanism of FIG. 15A at the LOW setting;

FIG. 16A is a side cross sectional view of an automatic inlet control mechanism according to one embodiment of the invention at a low setting;

FIG. 16B is a side cross sectional view of the inlet control mechanism of FIG. 16A at an intermediate setting;

FIG. 16C is a side cross sectional view of the inlet control mechanism of FIG. 16A at a high setting;

FIG. 16D is a magnified view of the adjustment mechanism of FIG. 16A;

FIG. 17A is a side cross sectional view of an automatic inlet control mechanism according to one embodiment of the invention in a closed position;

FIG. 17B is a side cross sectional view of the inlet control mechanism of FIG. 17A in an intermediate position;

FIG. 17C is a side cross sectional view of the inlet control mechanism of FIG. 17A in an open position;

FIG. 18A is a partial cross sectional view of an air compressor unit having an automatic inlet control mechanism according to one embodiment of the invention;

FIG. 18B is a magnified side cross sectional view of the automatic inlet control mechanism of FIG. 18A;

FIG. 19A is a partial cross sectional view of an air compressor unit having an automatic inlet control mechanism according to one embodiment of the invention;

FIG. 19B is a magnified side cross sectional view of the automatic inlet control mechanism of FIG. 19A;

FIG. 20A is a side cross sectional view of an automatic inlet control mechanism according to one embodiment of the invention in a closed position;

FIG. 20B is a side cross sectional view of the inlet control mechanism of FIG. 20A in a closed, intermediate position;

FIG. 20C is a side cross sectional view of the inlet control mechanism of FIG. 20A in an open position;

FIG. 21A is a side cross sectional view of an automatic inlet control mechanism according to one embodiment of the invention in a fully closed position;

FIG. 21B is a side cross sectional view of the inlet control mechanism of FIG. 21A in a closed, intermediate position;

FIG. 21C is a side cross sectional view of the inlet control mechanism of FIG. 21A in a fully open position;

FIG. 22A is a side cross sectional view of an automatic inlet control mechanism according to one embodiment of the invention in a fully closed position;

FIG. 22B is a side cross sectional view of the inlet control mechanism of FIG. 22A in a fully open position;

FIG. 23A is a side cross sectional view of an automatic inlet control mechanism according to one embodiment of the invention in a fully closed position;

FIG. 23B is a side cross sectional view of the inlet control mechanism of FIG. 23A in a fully open position;

FIG. 24A is a side cross sectional view of an automatic inlet control mechanism according to one embodiment of the invention in a fully closed position;

FIG. 24B is a side cross sectional view of the inlet control mechanism of FIG. 24A in a fully open position;

FIG. 25A is a front perspective view of an individual labyrinth restrictor of FIGS. 24A and B;

FIG. 25B is a rear view of the labyrinth restrictor of FIG. 25A;

FIG. 25C is a rear perspective view of the labyrinth restrictor of FIG. 25A;

FIG. 25D is a side view of the labyrinthine restrictor of FIG. 25A;

FIG. 27A is a side cross sectional view of an automatic inlet control mechanism according to one embodiment of the invention in a fully closed position;

FIG. 27B is a magnified side cross sectional view of the restriction in the vent passageway of the inlet control mechanism of FIG. 27A;

FIG. 27C is a side cross sectional view of the inlet control mechanism of FIG. 27A in a fully open position;

FIG. 28A is a side cross sectional view of an automatic inlet control mechanism according to one embodiment of the invention at a closed position;

FIG. 28B is a side cross sectional view of the inlet control mechanism of FIG. 28A at an intermediate position;

FIG. 28C is a side cross sectional view of the inlet control mechanism of FIG. 28A at an open position;

FIG. 29A is a side cross sectional view of a compressor pump having an automatic inlet control mechanism according to one embodiment of the invention in a closed position;

FIG. 29B is a side cross sectional view of the compressor pump of FIG. 29A in an open position;

FIG. 30A is a side cross sectional view of a compressor pump having an automatic inlet control mechanism according to one embodiment of the invention in a closed position; and

FIG. 30B is a side cross sectional view of the compressor pump of FIG. 30A in an open position.

### **Detailed Description**

Referring to the drawings, similar reference numerals are used to designate the same or corresponding parts throughout the several embodiments and figures. In some drawings, some specific embodiment variations in corresponding parts are denoted with the addition of lower case letters to reference numerals.

FIG. 1 depicts a typical wheeled portable reciprocating air compressor unit **32a**. The compressor unit **32a** includes a compressor pump **48a** mounted on an air reservoir **50** that forms a structural chassis to support the various components of the compressor unit **32a**. The compressor unit **32a** is supported with one or more legs **52** and wheels **54** that are positioned near the ends of the air reservoir **50**. A handle **56** allows one end of the compressor unit **32a** to be lifted off of its legs **52** to enable the compressor unit **32a** to be moved about on its wheels **54**.

An electric motor **58** and pressure switch **60** are also mounted on the air reservoir **50**. Although FIG. 1 depicts an electric motor, it will be appreciated that other types of power plants can be similarly implemented and are within the contemplated scope of the invention. The electric motor **58** is connected to draw electrical current from an electrical circuit (not shown) when the pressure switch **60** assumes an ON position. When the pressure switch **60** assumes an ON position, the motor **58** drives a pulley **34** connected to a crank shaft **62** on the compressor pump **48a** with a drive belt **65**. Although the crank shaft **62** is depicted as being belt driven in FIG. 1, it will be appreciated that the invention can be similarly implemented into a direct drive system in which rotational energy is transferred directly from a motor or other power plant to the crankshaft of a compressor pump through a shaft, gear, or other connective mechanism. In some embodiments, the pulley **34** can also function as a flywheel or, alternatively a separate flywheel (not shown) can be connected to the crankshaft **62**. The pressure switch **60** is configured to be responsive to air pressure within the air reservoir **50** and to allow operation of the electric motor **58** when the magnitude of the pressure within the air reservoir **50** falls below a predetermined magnitude. A screen guard **66** encloses the drive belt **65** and pulley **34**.

Although FIG. 1 depicts an air compressor unit **32a** having basic compressor components arranged in a typical single reservoir configuration, it will be appreciated that other portable compressor unit configurations are also possible. Such compressor units include those having upright standing, pancake, spherical or multiple air reservoirs and/or liftable, all legged, tailored, wheelbarrow, or sliding chassis configurations. Other similar variations are also possible and are contemplated to be included within the types of portable reciprocating air compressor units that are suitable for use with the invention.

FIG. 1 includes a partial cross sectional view of internal components within the compressor pump **48a** to further illustrate their relation to the rest of the compressor unit **32a**. An automatic inlet control mechanism **36a** is connected to a threaded inlet port **40a** of a compression cylinder inlet **38a**. The inlet control mechanism **36a** and compression cylinder inlet **38a** allow air to enter the compressor pump **48a** during each reciprocation of a piston **42** that is

located within a compression cylinder **44**. The inlet port **40a** is positioned to channel air from the inlet control mechanism **36a** to a cylinder inlet chamber **46a** which receives air before the air is channeled into the compression cylinder **44** through a cylinder inlet valve **64** positioned within a cylinder inlet hole **66**. The cylinder inlet hole **66** and cylinder inlet valve **64** can be included as part of a valve plate **68** that is positioned between the cylinder inlet chamber **46a** and compression cylinder **44**. The cylinder inlet valve **64** is unidirectional in that it only allows air to flow through the cylinder inlet hole **66** from the cylinder inlet chamber **46a** when, during an intake stroke (downward as depicted in FIG. 1) of the piston **42**, the piston **42** draws air into the compression cylinder **44**. During a compression stroke (upward as depicted in FIG. 1) of the piston **42**, the cylinder inlet valve **64** closes to prevent air from flowing from the compression cylinder **44**, through the cylinder inlet hole **66** and back into and through the cylinder inlet chamber **46a**.

The electric motor **58** effects reciprocation of the piston **42** by turning the pulley **34** and crankshaft **62** of the compressor pump **48a** with the drive belt **65**. The crankshaft **62** in turn causes reciprocation of a piston shaft **70** which drives the piston **42**, the piston shaft **70** being connected to the piston **42** with a piston pin **72**. The amount of work that the electric motor **58** must perform to cause the reciprocation of the piston **42** ultimately depends on the amount of air that is drawn through the compression cylinder inlet **38a** during each piston reciprocation. This is due to the fact that the amount of air that is drawn through the compression cylinder inlet **38a** ultimately determines the amount of air that the piston **42** can draw into the compression cylinder **44** and compress during each reciprocation. Thus, the amount of energy that the electric motor **58** must exert to run the compressor unit **32a** is directly dependent on the amount of air that is permitted to pass through the automatic inlet control mechanism **36a** during each reciprocation.

A compression cylinder outlet **74a** is positioned to receive air that has been compressed in the compression cylinder **44** and to channel air from the compression cylinder **44** out of the compressor pump **48a** during each compression stroke of the piston **42**. The compression cylinder outlet **74a** includes a cylinder outlet chamber **76a** for receiving air that has been

compressed in the compression cylinder **44**, an outlet port **78**, and a unidirectional cylinder outlet valve **80** located in a cylinder outlet hole **82** for channeling air into the cylinder outlet chamber **76a**. The cylinder outlet hole **82** and cylinder outlet valve **80** can be included as part of the valve plate **68** that is positioned between the compression cylinder **44** and cylinder outlet chamber **76a**. The cylinder outlet valve **80** is unidirectional in that it only allows air to flow through the cylinder outlet hole **82** and into the cylinder outlet chamber **76a** when, during a compression stroke of the piston **42**, the piston **42** expels air from the compression cylinder **44**. During an intake stroke of the piston **42**, the cylinder outlet valve **80** closes to prevent air from flowing from the cylinder outlet chamber **76a** back through the cylinder outlet hole **82** and into the compression cylinder **44**.

A discharge tube **84** is connected to the outlet port **78** to channel compressed air from the compressor pump **48a** to the air reservoir **50**. A check valve **86** is positioned at the end of the discharge tube **84** to allow air to flow from the discharge tube **84** into the air reservoir **50** while preventing backflow from the reservoir **50** into the discharge tube **86** and to prevent loss of air pressure from within the reservoir **50**.

The pressure switch **60** is connected to the electric motor **58** and is mounted at a location that allows the pressure switch **60** to sense the pressure of air contained within the air reservoir **50**. As air is forced into the air reservoir **50**, pressure in the air reservoir **50** increases. When the air pressure within the air reservoir **50** reaches a predetermined maximum magnitude of pressurization, the pressure switch **60** assumes an OFF position since additional air compression is not necessary. Once the air pressure within the air reservoir **50** falls below a minimum predetermined magnitude, the pressure switch **60** assumes an ON position, allowing the electric motor **58** to cause the compressor pump **48a** to add compressed air to the air reservoir **50** until the air pressure within the air reservoir **50** rises to the predetermined maximum magnitude at which time the pressure switch **60** returns to an OFF position. However, the amount of air that is compressed, and consequently the amount of work that is performed by the electric motor **58** with each reciprocation of the piston **42**, will continue to

depend on the amount of air that is permitted to enter the compression cylinder through the compression cylinder inlet **38a**

Since it is the electric motor **58** that is responsible for turning the drive belt **65** and pulley **34** to effect reciprocation of the piston **42**, the electric motor **58** must also provide sufficient energy to contend with additional loads resulting from combined inertial and compression loaded resistance of the piston **42** and other components of the compressor pump **48a**. Thus, if air is permitted to freely enter the compression cylinder **44** through the compression cylinder inlet **38a**, the electric motor **58** must contend with an increased starting torque that includes both with the compression loaded resistance of the piston **42** and the combined inertial resistance of the piston **42** and other components of the compressor unit **32a**. If air is restricted from entering the compression cylinder **44** through the compression cylinder inlet **38a**, the electric motor **58** need only contend with the combined inertial resistance of the piston **42** and other components of the compressor unit **32a** once air is removed from the compression cylinder inlet **38a** and compression cylinder **44**.

During operation, the rotating crankshaft **62**, pulley **34**, drive belt **65**, and other components of the compressor unit **32a** rotate at an operating speed and therefore store a sufficient amount of angular momentum to substantially reduce the amount of high speed torque that must be exerted by the electric motor **58** to maintain the reciprocating motion of the piston **42**. This allows the compressor pump **48a** to devote more of the total torque output of the electric motor **58** to drawing air into the compression cylinder **44**, compressing the air, and discharging the air into the air reservoir **50**.

However, prior to operation, the crankshaft **62**, pulley **34**, and other components do not rotate at an operating speed and therefore do not provide angular momentum that to assist the electric motor **58** in causing the reciprocation of the piston **42** while the piston is compression loaded. Therefore, in order to reduce the total torque output required from the electric motor **58** at the start of operation, i.e. in order to reduce the starting torque, it is necessary to temporarily remove the compression loaded resistance of the piston **42** until the motor **58** overcomes the inertial resistance of the compressor pump **48a**, allowing the compressor pump **48a** to first

reach a full operating speed and restore angular momentum to the crankshaft **62**, pulley **34**, and other components of the compressor unit **32a**.

The automatic inlet control mechanism **36a** is configured to allow for the temporary removal of piston compression loading until the compressor pump **48a** reaches a full operating speed. FIG. 1 depicts the inlet control mechanism **36a** connected to the inlet port **40a** of the compressor unit **32a**, the inlet control mechanism **36a** being shown in a closed position. A magnified view of the inlet control mechanism **36a** of FIG. 1 is depicted in FIG. 2A. An exploded view depicting the components of the inlet control mechanism is depicted in FIG. 3.

Comparing FIGS. 1, 2A, and 3, the control mechanism **36a** includes a mechanism body **88a** having a valve cavity **90a** that is divided into a valve control chamber **92a** and a valve inlet chamber **94a**. The mechanism body **88a** can include an inlet segment **87a** and a control segment **89a** that can be detached from each other prior to assembly to allow for the installation of a valve piston assembly **96a** and/or other mechanism components into the valve cavity **90a**. A male connector **91** on the inlet segment **87a** allows for engagement with a female connector **93** on the control segment **89a**, the male connector **91** and female connector **93** being snap connected when the mechanism body **88a** is assembled. When the mechanism body **88a** is assembled, the valve piston assembly **96a** is positioned between the valve control chamber **92a** and valve inlet chamber **94a** and is configured to reciprocate within the valve cavity **90a** while preventing air from flowing directly between the valve control chamber **92a** and valve inlet chamber **94a**.

A valve inlet **98a** extends through the mechanism body **88a** and allows air to flow from the atmosphere surrounding the compressor unit **32a** into the valve inlet chamber **94a**. The valve inlet **98a** can include a filter **100a** to remove impurities from air that passes through the valve inlet **98a** before the air enters the valve inlet chamber **94a**. A valve outlet **102a** includes a valve outlet hole **104a** positioned to allow air to flow from the valve inlet chamber **94a** into the compression cylinder inlet **38a**. The valve outlet **102a** is threaded to allow for connection to the inlet port **40a** of the compression cylinder inlet **38a**. The valve outlet hole **104a** is sized to allow a sufficient amount of air to flow from the inlet control mechanism **36a** to the compression

cylinder inlet **38a** to allow the compressor unit **32a** to produce air at its predetermined rate of production. The valve outlet hole **104a** can further include a tapered portion **103a**.

The valve piston assembly **96a** includes a valve piston **108a**, a diaphragm **106**, a valve stem **110a**, and a valve stem seal **116a** that are configured to reciprocate within the valve cavity **90a** along a valve axis **112**. Within the valve cavity **90a**, the diaphragm **106** forms a seal between the inside surface of the mechanism body **88a** and the rest of the valve piston assembly **96a** to prevent air from moving directly between the valve control chamber **92a** and valve inlet chamber **94a**. A spring biasing member **114a** produces a force that biases the valve piston assembly to move toward the valve inlet chamber **94a** and away from the valve control chamber **92a** to a position within the inlet control mechanism **36a** in which the valve stem seal **116a** contacts the inside surface of the mechanism body **88a** to prevent air from flowing from the valve inlet chamber **94a** through the valve outlet **102a**.

A vent passageway **118a** extends through the valve stem **110a**, opening to the valve control chamber **92a** and allowing for the communication of air between the valve control chamber **92a** and valve outlet **102a** or compression cylinder inlet **38a** through a stem hole **120**. An orifice **122a** forms a restriction to air that flows through the vent passageway **118a**, delaying the rate at which air can communicate between the valve control chamber **92a** and valve outlet **102a** or compression cylinder inlet **38a**.

The valve stem **110a** also includes a sliding surface **124** on which the valve stem seal **116a** reciprocates in response to the movement of the valve stem **110a** with the valve piston assembly **96a** and/or the air pressure differential between the compression cylinder inlet **38a** and valve inlet chamber **94a**. The valve stem seal **116a** can be constructed of rubber, teflon, a resilient polymer, or any other material that allows for sliding or reciprocation of the valve stem seal **110a** along the sliding surface **124** while also allowing for the creation of a seal between the sliding surface of the valve stem **110a** and the inside surface of the mechanism body **88a** when the piston assembly is in a position within the valve cavity **90a** that prevents air from flowing from the valve inlet chamber **94a** to the compression cylinder inlet. A lip **126** and an

expanded radius **128** are positioned at opposite ends of the sliding surface **124** to restrict the reciprocating movement of the valve stem seal **116a**.

To better understand the operation of the automatic inlet control mechanism **36a**, consider the air compressor unit **32a** prior to operation, as depicted in FIGS 1 and 2A. Electric current from an electric circuit (not shown) is not connected to the pressure switch **60** since the compressor unit **32a** is either not in use (power OFF) or is instead in use (power ON) but air pressure within the air reservoir **50** is greater than a predetermined minimum magnitude. In either case, the pressure switch **60** does not permit electric current to flow to reach the electric motor **58**. The electric motor **58** does not cause rotation of the drive belt **65**, pulley **34**, and drive shaft **62**. Therefore, the piston **42** does not reciprocate within the compression cylinder **44** and air is neither drawn through the cylinder inlet valve **64** nor forced through the cylinder outlet valve **80** in the compressor pump **48a**. The spring biasing member **114a** forces the valve piston assembly **96a** away from the valve control chamber **92a** and toward the valve inlet chamber **94a**. The valve stem seal **116a**, having a larger diameter than part of the tapered portion **103a** of the valve outlet **102a**, seals between the valve outlet **102a** and sliding surface **124** of the valve stem **110a** as the expanded radius **128** forces the valve stem seal **116a** against the tapered portion **103a** under the force of the spring biasing member **114a**. The resulting seal between the valve stem **110a** and valve outlet **102a** prevents air from the atmosphere surrounding the air compressor unit from **32a** entering the compression cylinder **44** through the valve inlet chamber **94a**.

Now consider the compressor unit **32a** when electric current is initially connected to the pressure switch **60** (power ON) and/or when pressure within the air reservoir **50** falls below a predetermined minimum magnitude while power is ON. The pressure switch **60** senses the low air pressure within the air reservoir **50** and in response connects the electric motor **58** to electric current from the electrical circuit. The motor **58** begins to rotate the drive belt **65**, pulley **34**, and drive shaft **62** to initiate reciprocation of the piston **42**. However, the motor **58** must contend with the inertial resistance of each of these components. In addition, the motor **58** must also contend with any air that is present within the compressor pump **48a** or discharge tube **84**.

However, the valve stem seal **110a** and valve stem seal **116a** prevent air from the atmosphere surrounding the compressor unit **32a** from entering the compressor pump **48a** through the inlet control mechanism **36a**.

As the piston **42** begins to reciprocate, remaining air is quickly drawn out of the cylinder inlet chamber **46a** and forced through the cylinder outlet valve **80** into the cylinder outlet chamber **76a** and discharge tube **84**. During a very short time interval, the speed of the initial rotation of the drive belt **65**, pulley **34**, and drive shaft **62** and the speed of reciprocation of the piston **42** is very low. During this very short interval, the electric motor **58** must bear the combined inertial and compression loaded resistance of the piston **42** and other components. Thus, during this short interval, the combined loads cause the electric motor **58** to experience a high current draw or "current spike."

However, after a very small number of piston reciprocations, most of the air initially present in the cylinder inlet chamber **46a** is removed by the reciprocating piston **42**. Most of the air is removed from the cylinder inlet chamber **46a** while the piston **42** reciprocates at a very low relative speed. Since the valve stem **110a** and valve stem seal **116a** prevent additional amounts of air from entering the compressor pump **48a** from the atmosphere through the valve inlet **98a** of the inlet control mechanism **36a**, air drawn through the vent passageway **118a** from the valve control chamber **94a** becomes the primary source of air to the compression cylinder inlet **38a** as the speed of the electric motor **58** and the reciprocation rate of the piston **42** begin to increase.

The air drawn through the vent passageway **118a** from the valve control chamber **94a** continues to be the primary source of air to the compression cylinder inlet **38a** as long as the valve piston assembly **96a** is in a position that prevents air from flowing from the valve inlet chamber **94a** to the compressor cylinder inlet **38a**. However, the orifice **122a** forms a restriction that limits the rate at which air can be drawn into the compression cylinder inlet **38a** through the vent passageway **118a**. As a result of this restriction, the amount of air that can be drawn into the compression cylinder inlet **38a** from the valve control chamber **92a** during a given time interval is very small compared to the amount of air that can be drawn from the valve inlet

chamber **94a** when the valve piston assembly **96a** is in a position that does not prevent air from flowing between the valve inlet chamber **94a** and compression cylinder inlet **38a**.

Consequently, compression loading of the piston **42** is greatly reduced as long as the valve control chamber **92a** remains the primary source of air to the compression cylinder inlet **38a**. This reduction in compression loading of the piston **42** allows the electric motor **58** to devote more total torque output to overcoming inertial resistance as the speed of the motor **58** and reciprocation rate of the piston **42** increase. Since compression loading of the piston **42** is reduced, the compressor unit **32a** produces compressed air at less than its predetermined rate of production. However, the reduction in initial compression loading can be effective in significantly reducing wear of the electric motor **58** and/or can allow the motor **58** to be reduced in size to only that which is necessary to maintain the reciprocation of the piston **42** once the piston has achieved an operating speed. This can in turn allow for a substantial reduction in wear, component cost, or energy usage.

As the speed of the motor **58** and the reciprocation rate of the piston **42** continue to increase, air continues to be drawn through the vent passageway **118a**, orifice **122a**, and stem hole **120** from the valve control chamber **92a** into the cylinder inlet chamber **46a**. This reduces the amount of air pressure that is present within the valve control chamber **92a**. Atmospheric pressure within the valve inlet chamber **94a** is maintained by air communication through the valve inlet **98a**. The sealed separation between the valve inlet chamber **94a** and valve control chamber **92a** created by the diaphragm **106** results in a pressure differential between the chambers that begins to force the diaphragm **106** and the rest of the valve piston assembly **96a**, against the force of the spring biasing member **114a** and toward the valve control chamber **92a** to an intermediate position within the valve cavity **90a**.

FIG. 2B depicts the inlet control mechanism **36a** in which the valve piston assembly **96a** is located at such an intermediate position within the valve cavity **90a**. As the valve stem **110a** moves toward the valve control chamber **92a**, very little pressure continues to occupy the compression cylinder inlet **38a** though atmospheric pressure continues to exist within the valve inlet chamber **94a**. This creates a pressure differential that continues to force the valve stem

seal **116a** against the tapered portion **103a** of the valve outlet **102a**. As the valve stem **110a** moves with the rest of the valve piston assembly **96a** toward the valve control chamber **92a**, the valve stem seal **116a** slides against the sliding surface **124** of the valve stem **110a**, maintaining the seal between the valve stem **110a** and the inside surface of the mechanism body **88a** while continuing to prevent air from flowing from the valve inlet chamber **94a** and compression cylinder inlet **102a**. The valve stem **110a** is normally configured so that the valve stem seal **116a** continues to seal between the valve stem **110a** and mechanism body **88a** until the electric motor **58** and compressor unit **32a** achieve an operating speed.

As the piston **42a** continues to draw air from the valve control chamber **92a**, the pressure differential between the valve inlet chamber **94a** and compression cylinder inlet **38a** continues to force the valve stem seal **116a** against the tapered portion **103a** of the valve outlet **102a** until the valve stem seal **116a**, sliding across the sliding surface **124**, contacts the lip **126** of the valve stem **110a**. The lip **126** forces the valve stem seal **116a** away from the tapered portion **103a** of the valve outlet **102a**. The valve piston assembly **96a** continues to move toward the valve control chamber **92a** until the air in the valve control chamber **92a** is at a sufficiently reduced pressure level that enables atmospheric pressure in the valve inlet chamber **94a** to overcome the force of the spring biasing member **114a** sufficiently to move the valve piston **108a** to contact the mechanism body **88a** as shown in FIG. 2C. This movement creates an air space **130a** allowing air from the valve inlet chamber **92a** and atmosphere to enter the compression cylinder inlet **38a**. However, by the time that the valve stem seal **116a** moves away from the mechanism body **88a**, the electric motor **58** and compressor unit **32a** will normally have achieved an operating speed and are therefore better equipped to deal with additional compression loading against the piston **42**.

The amount of time required for the valve piston assembly **96a** to move to a position, such as that depicted in FIG. 2C, that does not prevent air from flowing from the valve inlet chamber **94a** through the valve outlet **102a** into the compression cylinder inlet **102a** depends on the rate at which air can be drawn by the piston **42a** from the valve control chamber **94a**, which in turn depends on the size of the orifice **122a**. Thus, the amount of time during which the

automatic inlet control mechanism **36a** removes compression loading on the piston depends on the size or effective size of the vent restriction of air flowing through the vent passageway **118a**. This amount of time can be preselected by incorporating an orifice or other restriction having a size or effective size that corresponds to the rate of allowed air flow allowing for sufficient time for the compressor unit **32a** to achieve a desired operating speed while unloaded.

It will be appreciated that the invention can be similarly implemented in continuously operated compressor units. Referring now to FIG. 4, an air compressor unit **32b** is depicted in which a pilot valve **132b** takes the place of a pressure switch to enable the electric motor **58** to run continuously without continuously causing the compressor pump **48b** to add compressed air to the air reservoir **50**. The pilot valve **132b** is positioned on the air reservoir **50** and is configured to be responsive to the magnitude of air pressure that is contained within the air reservoir **50**. The pilot valve **132b** communicates pneumatically through a pilot tube **134** with an inlet unloader **136** that is positioned on the compressor pump **48b**. The inlet unloader **136** includes an unloader pin **138** that is positioned to extend to and retract from the inlet unloader **136** to interfere with the operation of the cylinder inlet valve **64** and to prevent further reservoir pressurization when the reservoir **50** is fully pressurized to a predetermined maximum magnitude of pressurization.

Consider the air compressor unit **32b** when, due to usage of air pressure by devices connected to the compressor unit **32b**, the magnitude of air pressure contained within the air reservoir **50** falls below a predetermined minimum magnitude. The electric motor **58** will be at an idle speed, as explained below. The pilot valve **132b** senses low pressure within the reservoir **50** and assumes an OFF condition. In response, the pilot valve **132b** pneumatically communicates the OFF condition to the inlet unloader **136** by removing a pneumatic pressure signal from the pilot tube **134**. In turn, the inlet unloader **136** retracts the unloader pin **138** away from the inlet valve **64**, allowing the inlet valve **64** to operate to permit air to be drawn from the cylinder inlet chamber **46a** and through the cylinder inlet hole **66** and into the compression cylinder **44** during each intake stroke of the piston **42**, while preventing air from being expelled from the compression cylinder **44** back through the cylinder inlet chamber **46b** during each

compression stroke of the piston **69**. The pilot valve **132b** will continue to prevent the inlet unloader **136** from interfering with the inlet valve **64** as long as air pressure within the reservoir **50** remains below a predetermined maximum magnitude which is larger than the predetermined minimum magnitude.

Since the motor **58** runs continuously, the amount of air that is compressed with each reciprocation of the piston **42** and the amount of torque output required to continue reciprocation of the piston **42** will continue to depend on the amount of air that is permitted by the automatic inlet control mechanism **32b** to enter the compression cylinder inlet **38a**. When the pilot valve **132b** initially removes the pneumatic pressure signal from the pilot tube **134** to cause retraction of the unloader pin **138**, the valve piston assembly **96** is normally in a position in which the valve stem seal **116** prevents air from moving from the valve inlet chamber **94b** through the valve outlet **102b** and into the cylinder inlet chamber **46b**. Air from the valve control chamber **94b** becomes the primary source of air to the compression cylinder **44** for an interval of time until which the valve piston assembly **96a** moves to a position that allows for air to move from the valve inlet chamber **94b** through the valve outlet **102b** into the cylinder inlet chamber **46b**. Since during this interval, the amount of air that can flow from the valve control chamber **92b** into the compression cylinder inlet **38b** is restricted by the orifice **122b**, there is a substantial reduction in the amount of compression loading of the piston **42**.

As the piston **42** continues to reciprocate, the valve piston assembly **96b** gradually moves from an intermediate position that does not permit air to flow between the valve inlet chamber **94b** and valve outlet **102b** to an intermediate position that does permit airflow between the valve inlet chamber **94b** and valve outlet **102b**, and then continues to move to a fully open position that allows greater air flow to the compression cylinder inlet **38b**. This has the effect of allowing full compression loading to be reached gradually rather than suddenly. Although the compressor unit **32b** is a continuous-run system, such smooth operation can nevertheless substantially reduce wear, and can allow for the use of a smaller or less powerful power plant due to the more gradual compression loading. This further allows for reductions in both apparatus cost and energy consumption.

Now consider the same air compressor unit **32b** when, due to the compression of air by the piston **42**, the magnitude of air pressure contained within the reservoir **50** rises above the predetermined minimum magnitude. The pilot valve **132b** continues to pneumatically communicate the OFF condition to the inlet unloader **136** until the air pressure within the air reservoir **50** rises above the predetermined maximum magnitude. When the air pressure contained within the reservoir **50** rises above the predetermined maximum magnitude, the pilot valve **132b** senses that the reservoir **50** is fully pressurized and assumes an ON condition. In response, the pilot valve **132b** pneumatically communicates the ON condition to the inlet unloader **136** by adding a pneumatic pressure signal through the pilot tube **134**. In turn, the inlet unloader **136** extends the unloader pin **138** to contact the inlet valve **64** and to prevent the inlet valve **64** from closing during each compression stroke of the piston **42**. Although the open inlet valve **64** allows air to be drawn from the valve inlet chamber **94b** and cylinder inlet chamber **46b** through the inlet hole **66** into the compression cylinder **44** during each intake stroke of the piston **42**, the piston **42** also expels air from the compression cylinder **44** back through the inlet hole **66** into the cylinder inlet chamber **46b** and valve inlet chamber **94b**, valve inlet **98b**, and into the environment during each compression stroke as long as the inlet unloader **136** prevents the cylinder inlet valve **64** from closing.

Since the open inlet valve **64** prevents the piston **42** from removing air pressure from the cylinder inlet chamber **46b** and valve outlet **102b**, air is no longer drawn from the valve control chamber **92b** through the vent passageway **118b** and orifice **122b**. Consequently, the spring biasing member **114b** is free to force the valve piston assembly **96b** back toward the valve outlet **102b**. Moreover, since air pressure is restored within the valve outlet **102b** and compression cylinder inlet **38b**, air is free to return to the valve control chamber **92b** as the valve piston **108b** moves toward the valve inlet chamber **94b**. This continues until the valve piston assembly **96b** returns to a position that prevents air from moving from the valve inlet chamber **94b** to the valve outlet **102b**. However, the piston **42** continues to be prevented from drawing significant amounts of air from the valve control chamber **92b** as long as the unloader pin **138** prevents the inlet valve **64** from closing during each compression stroke of piston **42**.

The motor **58** then runs continuously at an idle speed, as explained below. However, the compressor pump **48b** will be prevented from adding air pressure to the reservoir **50**, regardless of the amount of electric current drawn by the motor **58** from the electrical circuit, the amount of air that is permitted by the automatic inlet control mechanism **36b** to enter through the compression cylinder inlet **38b**, or the amount of torque output that is available from the electric motor **58**, until the pilot valve **132b** again senses that reservoir pressure is below the predetermined minimum magnitude and accordingly removes its pneumatic pressure signal from the pilot tube **134**.

It will be further appreciated that the invention can be implemented into compressor units having different types of power plants. For example, FIG. 5 depicts a continuous drive compressor unit **32c** having a gasoline engine **140** configured to effect reciprocation of the piston **42** by rotating the pulley **34** and crankshaft **62** with the drive belt **65**. Being configured for continuous operation, the compressor unit **32c** includes a pilot valve **132c** and pilot tube **134** that control the operation of an inlet unloader **136**. The pilot tube **134** is connected to an air cylinder **142** which is itself connected to effect adjustment of the engine throttle control **146** through a conduit **144**.

In operation, when air pressure within the reservoir **50** exceeds a predetermined maximum magnitude, the pilot valve **132c** assumes an ON condition reflecting the fully pressurized condition of the reservoir **50**. The pilot valve **132c** allows a limited amount of the pressure within the reservoir **50** to effect movement of a throttle piston (not shown) located within the air cylinder **142** to an IDLE position. The throttle piston is connected to a wire linkage (not shown) located within the conduit **144**. The wire linkage is connected directly to the throttle control **146** and causes the throttle control to move to an IDLE position when the throttle piston is in the IDLE position.

The pilot valve **132c** simultaneously communicates an ON condition to the inlet unloader **136** which in turn extends the unloader pin **138** to open the cylinder inlet valve **64** and prevent compression loading of the piston **42**. Since compression loading of the piston is therefore at least partially removed, it is only necessary for the engine **140** to exert sufficient

torque output to maintain the inertial rotation of the pulley **34**, crankshaft **62**, and other compressor components. Movement by the wire linkage of the throttle control **146** to the IDLE position lowers the engine speed of the gasoline engine **140** to an idle speed, that is a level that is sufficient to maintain the inertial rotation of compressor components in the absence of compression loading of the piston **42**, thereby increasing the overall efficiency of the engine **140**.

When air pressure within the reservoir **50** falls below a predetermined minimum magnitude, the pilot valve **132c** assumes an OFF condition reflecting the low air pressure contained within the reservoir **50**. The pilot valve **132c** removes air pressure from the air cylinder **142** accordingly. Spring returns (not shown) within the air cylinder **142** return the throttle piston to a FULL position, which in turn forces the wire linkage within the conduit **144** to move the throttle control to a FULL position allowing the engine **140** to resume operating speed. The pilot valve **132c** simultaneously communicates an OFF condition to the inlet unloader **136** which retracts the unloader pin **138** to allow for the continued compression of air by the compressor pump **48c**.

It will be appreciated that variations in the construction of the automatic inlet control mechanism are possible and within the contemplated scope of the invention. For example, FIGS. 6A-C depict an embodiment inlet control mechanism **36d** having open valve inlets **98d**. A filter surrounding the control mechanism **36d** is omitted to maximize the intake of air into the valve control chamber once the valve piston assembly **96d** moves from a closed position, as depicted in FIG. 6A, past an intermediate position, as depicted in FIG. 6B, to a position that permits air to flow from the valve inlet chamber **94d** through the valve outlet **102d** to the compressor pump, as shown in FIG. 6C.

Other embodiments of the invention having open valve inlets may incorporate filter components at other locations within a mechanism body. For example, FIGS. 7A-C depict an embodiment automatic inlet control mechanism **36e** having a valve passageway filter **150** located adjacent the orifice **122e** on the valve stem **110e**. The valve passageway filter **150** prevents foreign particles from entering the control chamber **92e**.

To effect sealing between the valve stem **110e** and mechanism body **88e**, the valve stem **110e** is divided into an expanded radius portion **154e** and a reduced radius portion **152e**. FIG. 7A, depicts the inlet control mechanism **36e** in a closed position in which the piston assembly **96e** prevents air from flowing between the valve inlet chamber **94e** and valve outlet **102e**. The piston assembly **96e** is biased to this position with the spring biasing member **114e**. When the piston assembly **96e** is in this position, the reduced radius portion **152e** inserts into a non-tapered portion **156e** of the valve outlet **102e**. An edge **148e** of the expanded radius portion **154e** of the valve stem **110e** contacts the tapered portion **103e** of the valve outlet **102e**. In this position, the clearance between the reduced radius portion **152e** of the valve stem **110e** and non-tapered portion **156e** of the valve outlet **102e** is sufficiently small to prevent air from flowing between the valve inlet chamber **94e** and valve outlet **102e**. The contact between the edge **148e** of the expanded radius portion **154e** and the tapered portion of the valve outlet **102e** acts to further block the flow of air.

In operation, the piston **42** draws air from the control chamber **92e** through the vent passageway **118e** while creating a pressure differential between the vent inlet chamber **94e** and valve outlet **102e**, separated by the close proximity of the reduced radius portion **152e** of the valve stem **110e** to the non-tapered portion **156e** of the valve outlet **102e**. As air continues to be drawn from the valve control chamber **92e**, atmospheric pressure in the valve inlet chamber **94e** causes the piston assembly **96e** to move against the force of the spring biasing member **114e** and toward the valve control chamber **92e**, though the reduced radius portion **152e** of the valve stem **110e** continues to be in close proximity to the non-tapered portion **156e** of the valve outlet **102e**. FIG. 7B depicts the piston assembly **96e** that has moved to an intermediate position in which the reduced radius portion **152e** of the valve stem **110e** remains in close proximity to the non-tapered portion **156e** of the valve outlet **102e**. As the valve stem **110e** moves, as long as the reduced radius portion **152e** remains in close proximity to the non-tapered portion **156e** of the valve outlet **102e**, air continues to be blocked from entering the compression cylinder inlet **38e** from the valve inlet chamber **94e**.

FIG. 7C depicts the piston assembly **96e** after the force of the pressure differential between the valve inlet chamber **94e** and valve control chamber **92e** sufficiently overcomes the bias of the spring biasing member **114e** to move the piston assembly **96e** to an open position in which the reduced radius portion **152e** of the valve stem **110e** clears the non-tapered portion **156e** of the valve outlet **102e**. This creates an air space **130e** through which air can move from the environment surrounding the inlet control mechanism **36e** and from the valve inlet chamber **94e** to the valve outlet **102f**. The amount of time required for the piston assembly **96e** to move to a position that allows air to move from the valve inlet chamber **94e** to the valve outlet **102f** depends on the rate at which air can be drawn through the vent passageway **118e** from the valve control chamber **92e** as permitted by the vent restriction that is created by the orifice **122e**. It follows that the amount of time in which the control mechanism **36e** removes piston compression loading depends on the amount of time that the reduced radius portion **152e** of the valve stem **110e** remains in close proximity to the non-tapered portion **156e** of the valve outlet **102e**, as permitted by the vent restriction created by the orifice **122e**.

FIG. 8A depicts an automatic inlet control mechanism **36f** in which the valve outlet **102f** does not include a tapered portion. The valve stem **110f** includes an expanded radius portion **154f** and a reduced radius portion **152f**, the expanded radius portion **154f** being dimensioned to allow for insertion into the valve outlet **102f** without a substantial amount of clearance.

FIG. 8A depicts the inlet control mechanism **36f** in a closed position in which the piston assembly **96f**, due to its insertion into the valve outlet **102f**, prevents air from flowing between the valve inlet chamber **94f** and valve outlet **102f**. The piston assembly **96f** is biased to this position with the spring biasing member **114f**. In this position, the clearance between the expanded radius portion **154f** of the valve stem **110f** and the valve outlet **102f** is sufficiently small to prevent air from flowing between the valve inlet chamber **94f** and valve outlet **102f**. Guides **160** restrict lateral movement of the valve stem **110f** and center the valve stem **110f** as it reciprocates along the valve axis **112f**.

In operation, the piston **42** draws air from the control chamber **92f** through the vent passageway **118f** while creating a pressure differential between the vent inlet chamber **94f** and

valve outlet **102f**, separated by the close proximity of the expanded radius portion **154f** of the valve stem **110f** to the valve outlet **102f**. As air continues to be drawn from the valve control chamber **92f**, atmospheric pressure in the valve inlet chamber **94f** causes the piston assembly **96f** to move against the bias of the spring biasing member **114e** and toward the valve control chamber **92f**, though the expanded radius portion **154f** of the valve stem **110f** continues to be in close proximity to the valve outlet **102f**.

FIG. 8B depicts the piston assembly **96f** that has moved to an intermediate position in which the expanded radius portion **154f** of the valve stem **110f** remains in close proximity to the valve outlet **102f**. As the valve stem **110f** moves, it continues to block air from entering the compression cylinder inlet **38f** from the valve inlet chamber **94e** as long as the expanded radius portion **154f** remains in close proximity to the valve outlet **102f**.

FIG. 8C depicts the piston assembly **96f** after the force of the pressure differential between the valve inlet chamber **94f** and valve control chamber **92f** sufficiently overcomes the bias of the spring biasing member **114f** to move the piston assembly **96f** to an open position in which the expanded radius portion **154f** of the valve stem **110f** has cleared the valve outlet **102f**. This creates an air space **130f** through which air can move from the environment surrounding the inlet control mechanism **36f** through the valve inlet chamber **94f** to the valve outlet **102f**. The amount of time required for the piston assembly **96f** to move to a position that allows air to move from the valve inlet chamber **94f** to the valve outlet **102f** depends on the rate at which air can be drawn through the vent passageway **118f** from the valve control chamber **92f** as permitted by the vent restriction created by the orifice **122f**. It follows that the amount of time in which the control mechanism **36f** removes piston compression loading depends on the amount of time that the expanded radius portion **154f** of the valve stem **110f** remains in close proximity to the valve outlet **102f**, as permitted by the vent restriction created by the orifice **122e**.

Some embodiments having non-tapered valve outlets also allow for the use of sliding valve stem seals to restrict air flow. FIGS. 9A-C depict an inlet control mechanism **36g** having a valve stem seal **116g** positioned to reciprocate along a reduced radius portion **152g** of a valve

stem **110g**. Lost sliding motion of the valve stem seal **116g** is restricted with a stem clip **158g** that is positioned along the length of the reduced radius portion **152g** and the edge **148g** of an expanded radius portion **154g** of the valve stem **110g**. Guides **160** restrict lateral movement of the valve stem **110g** and center the valve stem **110g** as it reciprocates along the valve axis **112g**.

FIG. 9A depicts the control mechanism **36g** in a closed position in which the spring biasing member **114g** biases the piston assembly **96g** away from the valve control chamber **92g**. The edge **148g** of the expanded radius portion **154g** contacts the valve stem seal **116g** which seals against the mechanism body **88g**. This prevents air from moving from the valve inlet chamber **94g** to the valve outlet **102g** and creates a pressure differential as air is drawn through the valve outlet hole **104g**.

As air is drawn through the vent passageway **118g**, the piston assembly **96g**, including the valve stem **110g**, moves against the force of the spring biasing member **114g** toward the valve control chamber **92g**. However, the pressure differential between the valve inlet chamber **94g** and valve outlet **102g** continues to force the sliding seal **116g** against the mechanism body **88g**, the reduced radius portion **152g** of the valve stem **110g** sliding through the valve stem seal **116g**. This continues until the piston assembly **96g** moves to an intermediate position in which the stem clip **158g** contacts the valve stem seal **116g**. This intermediate position is depicted in FIG. 9B.

The time required for the piston assembly **96g** to move to the intermediate position depicted in FIG. 9B depends on the rate at which air can be drawn from the valve control chamber **92g** as permitted by the vent restriction created by the orifice **122g**. If, from the intermediate position depicted in FIG. 9B, the piston assembly **96g** continues to move toward the valve control chamber **92g**, the stem clip **158g** pulls the valve stem seal **116g** away from the mechanism body **88g**. This causes the inlet control mechanism **36g** to assume an open condition as depicted in FIG. 9C, creating an air space **130g** that allows air to flow between the valve inlet chamber **94g** and valve outlet **102g**. Thus, the time required for the piston assembly **96g** to move past the intermediate position depicted in FIG. 9B determines the preselected

amount of time during which air from the environment is prevented from flowing from the valve inlet chamber **94g** to the compression cylinder inlet.

It will be further appreciated that the automatic inlet control mechanism can be constructed to operate without the use of a diaphragm. FIGS. 10A-C depict an inlet control mechanism **36h** having a valve piston **162** that is integrated into the structure of the valve stem **110h**. The valve piston **162** has a diameter that is sufficient to extend fully across the valve cavity **90h** as the valve piston assembly **96h** reciprocates along the valve axis **112**. As it reciprocates with the valve piston assembly **96h**, the valve piston **96h** seals against the inside surface of the mechanism body **88h** with a piston seal **164**, preventing air from flowing directly between the valve control chamber **92h** and valve inlet chamber **94h**. The piston seal **164** can be constructed of rubber, teflon, a resilient polymer, or any other material that allows for sliding or reciprocation of the valve piston **96h** against the inside surface of the mechanism body **88h**, eliminating the need for a diaphragm positioned between the valve stem **110h** and valve piston **96h**. In operation, the valve stem seal **116h** prevents air from flowing between the valve inlet chamber **94h** to the valve outlet **102h** until the valve piston assembly **96h** moves to an intermediate position as shown in FIG. 10B. As air is withdrawn from the valve control chamber **92h** through the vent passageway **118h** and orifice **122h**, atmospheric pressure in the valve inlet chamber **94h** forces the piston assembly **96h** toward the valve control chamber **92h**. Once the piston assembly moves past the intermediate position to an open position, such as that shown in FIG. 10C, the sliding seal **116h** clears the tapered portion **103h** to create an air space **130h**, allowing air to flow from the valve inlet chamber **94h** to the valve outlet **102h**.

Although the invention has been shown and described as having an automatic inlet control mechanism where the mechanism body is external to the compressor pump, it will be appreciated that in some embodiments, the inlet control mechanism can be integrated directly into the structure of the compressor pump. For example, FIG. 11A depicts a compressor pump **48i** having an automatic inlet control mechanism **36i** that includes a mechanism body **88i** integrated into the structure of the compressor pump **48i**. The mechanism body **88i** includes a removable portion **168i** that is threaded and sealed with an enclosure seal **174** to allow for

installation of components of the inlet control mechanism **36i** in the compressor pump **48i**. An external filter **166** is attached to a valve inlet **98i** leading to a valve inlet chamber **94i** located below a valve control chamber **92i**. A valve outlet partition **170** includes a valve outlet **102i** having a tapered portion **103i** and valve outlet hole **104i**. The valve piston assembly **96i** includes a piston **108i**, valve stem **110i**, and vent passageway **118i** configured to reciprocate vertically along a vertical valve axis **172**. When assuming a fully closed position, as shown in FIG. 11A, the valve stem **110i** extends fully through the valve outlet hole **104i** so that the stem hole **120** extends through the compression cylinder inlet **38i** and enters the compression cylinder inlet chamber **46i**. The valve stem seal **116i** prevents air from the atmosphere from flowing between the valve inlet chamber **94i** through the valve outlet hole **104i** to the valve outlet **102i**.

When air is drawn by the piston **42** from the control chamber **92i** through the valve passageway **118i** and cylinder inlet chamber **46i**, the valve piston assembly **96i** moves upward along the vertical valve axis **172** as depicted in FIG. 11B. This upward movement creates an air space **130i** between the valve stem seal **120** and tapered portion **103i** allowing air to enter the compression cylinder inlet **38i** from the valve inlet chamber **94i**.

While the invention has been shown in various embodiments having vent passageways that extend through valve stems, it will be appreciated that appropriate vent passageways can be configured in alternate positions as well. FIG. 12A depicts an embodiment compressor pump **48j** having an externally positioned inlet control mechanism **36j**. A vent passageway **118j** extends outside of the inlet control mechanism **36j** and compressor pump **48j** and is connected to the valve control chamber **92j** with a control chamber coupling **176** and connected to the cylinder inlet chamber **46j** with an inlet chamber coupling **178**. A vent orifice **122j** is positioned in the vent passageway **118j** near the control chamber coupling **176** to restrict the flow of air from the valve control chamber **92j** into the cylinder inlet chamber **46j**. The valve stem **110j** is solid along its length, preventing air from moving directly between the valve control chamber **92j** and valve outlet **102j**.

When the piston **42** reciprocates within the compression cylinder **44** while the valve piston assembly **96j** is in the position shown in FIG. 12A, air is drawn through the externally mounted vent passageway **118j** from the valve control chamber **92j** which becomes the primary source of air to the compression cylinder **44** and which loses air pressure as air is progressively drawn by the piston **42**. The rate at which air is drawn through the vent passageway **118j** depends on the size of the orifice **122j**. The valve control chamber **92j** continues to be the primary source of air to the compression cylinder **44** until atmospheric pressure within the valve inlet chamber **94j** forces the valve piston assembly **96j** to the open position shown in FIG. 12B, creating an air space **130j** through which air can enter the compression cylinder **38j** from the environment.

It will be further appreciated that in some embodiments, the period of time required for a valve piston assembly to move from a fully closed to a fully open position can also be controlled by changing the relative size of the inlet control mechanism and/or valve control chamber. For example, FIG. 13A depicts an embodiment compressor pump **48k** having an enlarged control segment **89k** of the mechanism body **88k** that effectively increases the size of the valve control chamber **92k**. In operation, the increased size of the valve control chamber **92k** increases the amount of time that is required for the piston **42** to draw a sufficient amount of air through the vent passageway **118k**, to produce a pressure differential between the valve inlet chamber **94k** and valve control chamber **92k** sufficient to overcome the force of the biasing spring **114k** to effect movement of the valve piston assembly **96k**. Thus, the increased size of the valve control chamber **92k** allows the vent passageway **118k** to continue to comprise the primary source of air to the compression cylinder inlet **38k** for a period of time after the piston **42** begins to draw air into the compression cylinder **42** without requiring lost mechanical motion by the valve stem seal **116** or other components of the inlet control mechanism **36k**.

Referring now to FIG. 13B, the piston assembly **96k** moves to an open position once a sufficient amount of air has been drawn through the orifice **122k** and vent passageway **118k** to create a pressure differential between the valve inlet chamber **94k** and valve control chamber **92k** sufficient to overcome the force of the biasing spring **114k**, creating an air space **130k** that

allows air to flow from the valve inlet chamber **94k** to the valve outlet **102k**. However, it will be appreciated that, depending on the requirements of a given specific embodiment, it may be necessary to construct the inlet control mechanism **36k** to have a valve control chamber **92k** that is significantly larger than corresponding control mechanisms incorporating lost mechanical motion of internal components to achieve a comparable period of delay before opening. It will be further appreciated that in some embodiments, a comparable period of delay can be achieved by adjusting the size of an orifice in a vent passageway to affect the rate at which air can be drawn from the valve control chamber. In addition, it is possible to control the period of delay by combining changes in both the orifice and control chamber sizes.

In some embodiments, the extent to which the piston assembly moves from the fully closed position can be manually limited, allowing for manual restriction of air flow between the atmosphere and compression cylinder. FIGS. 14A-C depict an embodiment inlet control mechanism **36I** having a stem restrictor **178I** that extends through the control segment **89I** of the mechanism body **88I**. The stem restrictor **178I** is configured to reciprocate along the valve axis **112I** and includes restrictor legs **180I** positioned to engage and limit the movement of the valve stem **110I** toward the valve control chamber **92I**. An adjustment cam **182I** is connected to rotate on the stem restrictor **178I** with a pivot **184**. The adjustment cam **182I** includes a low cam surface **186I**, a medium cam surface **188I**, and a high cam surface **190I** that are each positioned to contact the control segment **89I** of the mechanism body **88I** on its outside surface. The stem restrictor **178I** is spring biased to move along the valve axis **112I** toward the valve inlet chamber **94I** and is locked in place by the adjustment cam **182I** with the pivot **184**.

A cam lever **192** allows the adjustment cam **182I** to be manually rotated to selectively position the low, medium, or high cam surface **186I**, **188I**, or **190I** in contact with the mechanism body **88I**. The inlet control mechanism **36I** is depicted in the LOW position in FIG. 14A, the low cam surface **186I** being positioned adjacent the mechanism body **88I**. The low cam surface **186I** is located a relatively small distance from the pivot **184**, allowing the adjustment cam **182I** to lock the stem restrictor **178I** against its spring bias at a position that is relatively close to the valve inlet chamber **94I**. This in turn places the restrictor legs **180I** in a

position that restricts the valve stem **110I** to move no further than an open position that creates a relatively small air space **130I** between the valve stem **110I** and tapered portion **103I** of the valve outlet **102I**, allowing a maximum amount of air to pass from the valve inlet chamber **94I** that is less than when the control mechanism **36I** is in the MEDIUM or HIGH positions.

The inlet control mechanism **36I** is depicted in the MEDIUM position in FIG. 14B, the medium cam surface **188I** being positioned adjacent the mechanism body **88I**. The medium cam surface **188I** is located a medium distance from the pivot **184**, allowing the adjustment cam **182I** to lock the stem restrictor **178I** against its spring bias at a position that is a medium distance from the valve inlet chamber **94I**. This in turn places the restrictor legs **180I** in a position that restricts the valve stem **110I** to move no further than an open position that creates a medium sized air space **130I** between the valve stem **110I** and tapered portion **103I** of the valve outlet **102I**, allowing a maximum amount of air to pass from the valve inlet chamber **94I** that is less than when the control mechanism **36I** is in the HIGH position but greater than when the control mechanism **36I** is in the LOW position.

The inlet control mechanism **36I** is depicted in the HIGH position in FIG. 14C, the high cam surface **190I** being positioned adjacent the mechanism body **88I**. The high cam surface **190I** is located a relatively large distance from the pivot **184**, allowing the adjustment cam **182I** to lock the stem restrictor **178I** against its spring bias at a position that is relatively far away from the valve inlet chamber **94I**. This in turn places the restrictor legs **180I** in a position that restricts the valve stem **110I** to move no further than an open position that creates a relatively large air space **130I** between the valve stem **110I** and tapered portion **103I** of the valve outlet **102I**, allowing a maximum amount of air to pass from the valve inlet chamber **94I** that is greater than when the control mechanism **36I** is in the LOW or MEDIUM positions.

FIGS. 15A-D depict an embodiment inlet control mechanism **36m** having a stem restrictor **178m** that extends through a resilient ring **194** positioned within the control segment **89m** of the mechanism body **88m**. The stem restrictor **178m** is configured to reciprocate along the valve axis **112m** and includes restrictor legs **180m** positioned to engage and limit the movement of the valve stem **110m** toward the valve control chamber **92m**. A low adjustment

notch **196**, medium adjustment notch **198**, and high adjustment notch **200** are located along the length of the stem restrictor **178m**. The low, medium, and high adjustment notches **196**, **198**, and **200** are each positioned to compress and engage the resilient ring **194** to lock the stem restrictor **178m** against the mechanism body **88m**. A magnified cross sectional view of the engagement of the resilient ring **194** by the stem restrictor **178m** is depicted in FIG. 15D in the LOW position.

A restrictor handle **202** allows the stem restrictor **178m** to be manually adjusted to selectively compress and engage the resilient ring **194** with the low, medium, or high adjustment notches **196**, **198**, or **200**. The inlet control mechanism **36m** is depicted in the LOW position in FIG. 15A, the low adjustment notch **196** being positioned in engagement with the resilient ring **194** to lock with the mechanism body **88m**. The low adjustment notch **196** is located a relatively small distance from the restrictor legs **180m**.

This allows the restrictor legs **180m** to assume a position that restricts the valve stem **110m** to move no further than an open position that creates a relatively small air space **130m** between the valve stem **110m** and tapered portion **103m** of the valve outlet **102m**, allowing a maximum amount of air to pass from the valve inlet chamber **94m** that is less than when the control mechanism **36m** is in the MEDIUM or HIGH positions.

The inlet control mechanism **36m** is depicted in the MEDIUM position in FIG. 15B, the medium adjustment notch **198** being positioned in engagement with the resilient ring **194** to lock with the mechanism body **88m**. The medium adjustment notch **198** is located a medium distance from the restrictor legs **180m**. This allows the restrictor legs **180m** to assume a position that restricts the valve stem **110m** to move no further than an open position that creates a medium sized air space **130m** between the valve stem **110m** and tapered portion **103m** of the valve outlet **102m**, allowing a maximum amount of air to pass from the valve inlet chamber **94m** that is greater than when the control mechanism **36m** is in the LOW position but less than when the control mechanism **36m** is in the HIGH position.

The inlet control mechanism **36m** is depicted in the HIGH position in FIG. 15C, the high adjustment notch **200** being positioned in engagement with the resilient ring **194** to lock with the

mechanism body **88m**. The high adjustment notch **200** is located a relatively large distance from the restrictor legs **180m**. This allows the restrictor legs **180m** to assume a position that restricts the valve stem **110m** to move no further than an open position that creates a relatively large sized air space **130m** between the valve stem **110m** and tapered portion **103m** of the valve outlet **102m**, allowing a maximum amount of air to pass from the valve inlet chamber **94m** that is greater than when the control mechanism **36m** is in the LOW or MEDIUM positions.

FIGS. 16A-D depict an embodiment inlet control mechanism **36n** having a threaded stem restrictor **178n** that extends through a threaded portion **204** of the control segment **89n** of the mechanism body **88n**. The stem restrictor **178n** is configured to rotate about and reciprocate along the valve axis **112n** and includes restrictor legs **180n** that are positioned to engage and limit the movement of the valve stem **110n** toward the valve control chamber **92n**. A magnified cross sectional view of the threaded portion **204** of the mechanism body **88n** and the stem restrictor **178n** is depicted in FIG. 16D.

A restrictor knob **206** allows the stem restrictor **178n** to be manually rotated to adjust the maximum distance that the valve stem **110n** and valve piston assembly **96n** can move toward the valve control chamber **92n**. The inlet control mechanism **36n** is depicted in a position in FIG. 16A that restricts the valve stem **110n** to move no further than an open position that creates a relatively small air space **130n** between the valve stem **110n** and tapered portion **103n** of the valve outlet **102n**, allowing a maximum amount of air to pass from the valve inlet chamber **94n** that is of a relatively small magnitude.

The inlet control mechanism **36n** is depicted in a position in FIG. 16B that restricts the valve stem **110n** to move no further than an open position that creates an intermediate sized air space **130n** between the valve stem **110n** and tapered portion **103n** of the valve outlet **102n**, allowing a maximum amount of air to pass from the valve inlet chamber **94n** that is of an intermediate magnitude.

The inlet control mechanism **36n** is depicted in a position in FIG. 16C that restricts the valve stem **110n** to move no further than an open position that creates a relatively large air space **130n** between the valve stem **110n** and tapered portion **103n** of the valve outlet **102n**,

allowing a maximum amount of air to pass from the valve inlet chamber **94n** that is of a relatively large magnitude.

Some embodiments of the invention also allow for continuous operation of the compressor unit without requiring the use of an inlet unloader for actuation of the cylinder inlet valve. FIGS. 17A-C depict an inlet control mechanism **154o** having an equalization valve **208o** positioned within the control segment **89o** of the mechanism body **88o**. The equalization valve **208o** is connected through a pilot tube **134** to a pilot valve (not shown) mounted on the air reservoir of a compressor unit. The equalization valve **208o** includes an equalization piston **210** that is configured to reciprocate along an equalization valve axis **212** in a piston chamber **216**. The equalization piston **210** includes a piston ring **214** that allows the equalization piston **210** to seal against the walls of the piston chamber **216** during operation. The equalization piston **210** is connected to an equalization rod **214** that extends from the piston chamber **216** through a rod passage **222** into a ball chamber **220** where the equalization rod **214** engages a ball **218**. The rod passage **222** is sufficiently large to allow air to pass freely from the piston chamber **216** past the equalization rod **214** toward the ball chamber **220**.

The equalization piston **210** is biased with an equalization spring **226** to move to a position that is away from the ball chamber **220** (upwards as depicted in FIGS. 17A-C). The ball **218** also reciprocates along the equalization valve axis **212** within the ball chamber **220** and is biased with a ball spring **228** to move in the same direction as the equalization piston **210**. The ball **218** is sized to allow air to pass freely around between the ball **218** and ball chamber walls **230** but to seal against the upper taper **231** of the ball chamber **220** when pressed against the upper taper **231** by the ball spring **228**, preventing air flow from the rod passage **222** to the ball chamber **220**. An equalization inlet **226** allows air to freely enter the piston chamber **216** from the environment to maintain atmospheric pressure within the piston chamber **216**. A control inlet **234o** allows for the free passage of air between the ball chamber **220** and control chamber **92o**.

When used with a continuously running air compressor unit, the inlet control mechanism **36o** operates according to pneumatic signals received from the pilot valve. During operation, as

long as air pressure contained within the air reservoir of the compressor unit remains above a predetermined minimum magnitude, the pilot valve assumes an ON condition. In turn, the pilot valve sends a pressure signal to the equalization valve **208o** through the pilot tube **134**. The pressure signal forces the equalization piston **210** against the bias of the equalization spring **226**, forcing the equalization rod **214** to push the ball **218** against the bias of the ball spring **228** and away from the upper taper **231** of the ball chamber **220**. This position is depicted in FIG. 17A and allows air from the environment to freely enter the ball chamber **220** by way of the equalization inlet **232o**, piston chamber **216**, and rod passage **222**. This also allows air from the environment to freely enter the control chamber **92o** through the control inlet **234o** and maintain atmospheric pressure within the control chamber **92o** as long as the ball **218** remains away from the upper taper **231** of the ball chamber **220**.

Air pressure within the control chamber **92o** remains at atmospheric pressure as long as the pilot valve continues to send a pressure signal to the equalization valve **208o**. The orifice **122o** has a relative size that allows air to pass at a much slower rate than air can pass through the open equalization valve **208o** from the environment. Although the compressor unit operates continuously, air cannot be drawn through the vent passageway **122o** of the valve stem **110o** as quickly as it is supplied by the open equalization valve **208o**. As a result, no pressure differential exists between the valve control chamber **92o** and valve inlet chamber **94o** as long as the pressure signal continues and the inlet control mechanism **36o** does not open to allow air from the atmosphere to flow through the valve outlet **102o** to the compression cylinder.

When air pressure within the air reservoir falls below the predetermined minimum magnitude, the pilot valve assumes an OFF condition. In turn, the pilot valve removes the pressure signal from the equalization valve **208o** through the pilot tube **134**. With the pressure signal removed, the bias of the equalization spring **226** forces the equalization piston **210** away from the ball spring **228**, drawing the equalization rod **214** away from the ball **218**. The bias of the ball spring **228** forces the ball **218** against the upper taper **231** of the ball chamber **220**. This position is depicted in FIG. 17B and prevents air from the environment from entering the ball chamber **220** by way of the equalization inlet **232o**, piston chamber **216**, and rod passage

**222.** This also prevents air from the environment from entering the control chamber **92o** through the control inlet **234o**.

Since the ball **218** blocks the flow of air from the environment into the control chamber **92b**, air pressure contained within the control chamber **92b** begins to drop as air is drawn through the vent passageway **118o** and orifice **122o**. This creates a pressure differential between the valve control chamber **92o** and valve inlet chamber **94o** that forces the piston assembly **96o** toward the valve control chamber **92o**, eventually opening the control mechanism **36o** to the position depicted in FIG. 17C.

Once the inlet control mechanism **36o** is in the position depicted in FIG. 17C, the air compressor begins to add pressure to the air reservoir. This continues until the pressure within the air reservoir returns to a predetermined maximum magnitude that is greater than the predetermined minimum magnitude. When the air pressure within the reservoir reaches the predetermined maximum magnitude, the pilot valve again assumes an ON condition to restore the pressure signal to the equalization valve **208o**, removing the pressure differential between the valve inlet chamber **94o** and valve control chamber **92o** and returning the inlet control mechanism **36o** to the position depicted in FIG. 17A.

Although FIGS. 17A-C depict an equalization valve **208o** mounted within the mechanism body of the inlet control mechanism, it is also possible to mount an equalization valve externally. FIGS. 18A and B depict a compressor unit **32p** having an externally mounted equalization valve **208p** attached to the control segment **89p** of the mechanism body **88p**. The externally mounted equalization valve **208p** can be mechanically similar to the equalization valve **208o** positioned within the mechanism body **88o** in FIGS. 17A-C, the externally mounted equalization valve **208p** of FIGS. 18A-C being configured to allow air to be drawn from the environment through an equalization inlet **232p** to a control inlet **234p** leading to the control chamber **92p**. A magnified cross sectional view of the inlet control mechanism **36p** of FIG. 18A is depicted in FIG. 18B.

Referring again to FIG. 18A, the compressor unit can also include a combination valve **236p** that combines the functions of a check valve, pilot valve, air cylinder, and a discharge

unloader valve, the combination valve **236p**, being connected to the discharge tube **84** from the compressor pump **48p**, the pilot tube **134p**, air reservoir **50**, and the conduit **144** leading to the throttle control **146** of the gasoline engine **140**. In this combined configuration, the discharge unloader valve is responsive to the pilot valve and is configured to allow air that is compressed with the compressor pump **48p** to be channeled to the surrounding atmosphere through a discharge port **237** on the combination valve **236** rather than into the air reservoir **50** when the pilot valve assumes an ON condition. This occurs as the pilot valve sets the engine control throttle **146** to idle through the conduit **144** with the air cylinder **241**.

The automatic inlet control mechanism **36p** allows for a substantial size reduction in the discharge unloader valve compared to that which is required for a comparable compressor unit that does not have an inlet control. Consider the compressor unit **32p** of FIGS. 18A and B when the pilot valve of the combination valve **236p** assumes an ON condition. The equalization valve **208p** responds to the pilot valve by allowing air to pass from the control chamber **92p** through the equalization inlet **232p** to the environment, removing the pressure differential between the valve inlet chamber **94p** and valve control chamber **92p**. The piston assembly **96p** moves to a position that is depicted in FIGS. 18A and B that prevents air from moving from the valve inlet chamber **94p** to the valve outlet **102b** and compression cylinder inlet **38p**. As the piston **42** continues to reciprocate, the valve control chamber **92p** continues to be the primary source of air to the compression cylinder **44**, the air being drawn through the vent passageway **118p** and vent orifice **122p**. Although the pressure within the valve control chamber **92p** remains commensurate with atmospheric pressure, the amount of air that is drawn through the vent passageway **118p** is substantially restricted by the orifice **122p**. Thus, the amount of air that must be discharged by the discharge unloader valve in the combination valve **236p** is also substantially reduced.

Due to this substantial reduction in the amount of air that must be discharged, the structural size of the discharge unloader valve can also be substantially reduced. In some embodiments, the unloader opening of the valve can be reduced by an order of ten or more, significantly reducing apparatus cost.

Similar inlet control mechanisms can be implemented in electrically operated continuous drive compressor units as well. FIGS. 19A and B depict a compressor unit **32q** having an electric motor **58** and a combination valve **236q** that combines the functions of a check valve and pilot valve, being connected to the discharge tube **84** from the compressor pump **48q**, the pilot tube **134q**, and air reservoir **50**. FIG. 19B depicts a magnified cross sectional view of the inlet control mechanism **36q** which is similar to the inlet control mechanism **36p** of FIGS. 18A and B.

In some embodiments of the invention, the reciprocating motion of the piston assembly can be used to operate and/or actuate other components of the compressor unit. For example, FIGS. 20A-C depict a compressor unit **32r** having an automatic inlet control mechanism **36r** in which the piston assembly **96r** includes an actuation pin **238** mounted on the valve stem **110r** and positioned to reciprocate through a pin space **240** in the guide **160**. The actuation pin **238** allows the piston assembly **96r** to function as an actuator, the actuation pin **238** being sufficiently long to engage the venting stem **242** of a vent valve **244** positioned within the inlet segment **87r** of the mechanism body **88r** when the piston assembly **96r** is in the closed position as depicted in FIG. 20A. The vent valve **244** includes a stem seal **246** that is connected to reciprocate with the venting stem **242** and is biased with a stem spring to seal against the stem seat **248** when the actuation pin **238** is not in engagement with the venting stem **242** as shown in FIG. 20C. The vent valve **244** connects the valve inlet chamber **94r** to a vent passage **252** that can allow the attachment of a vent line **254**. The vent line **254** can itself be linked to a discharge tube or other component of the compressor unit that requires the release of air pressure when the compressor unit is not compressing air and when the inlet control mechanism **36r** is in the closed position, as shown in FIG. 20A.

Consider the inlet control mechanism **36r** either before or at the start of operation of a compressor unit. The inlet control mechanism **36r** is in a closed position as depicted in FIG. 20A with the valve stem **110r** preventing the flow of air between the valve inlet chamber **94r** and valve outlet **102r**. The actuation pin **238** pushes the venting stem **242** against the bias of the stem spring **248** to pull the stem seal **246** away from the stem seat **250**, allowing air to pass

from the valve inlet chamber **94r** through the vent passage **252** to the vent line **254**. Since the compressor unit has not yet begun to compress air, the discharge tube leading from the compressor pump to the air reservoir does not yet need to be pressurized. The vent line **254** can be connected to the discharge tube to allow pressure contained therein to escape through the vent valve **244** to the valve inlet chamber **94r**, valve inlet **98r**, and back into the atmosphere. As the piston assembly **96r** moves toward the valve control chamber **92r**, the actuation pin **238** disengages the venting stem **242** and allows the stem seal **246** to seal against the stem seat **250** under the force of the stem spring **248**, as depicted in FIG. 20B. By the time the piston assembly **96r** moves to a position that allows air to move from the valve inlet chamber **94r** to the valve outlet **102r** such that the compressor unit begins to compress air, as depicted in FIG. 20C, the vent valve **244** prevents air from being discharged to the atmosphere through the valve inlet chamber **94r**, allowing compressed air to instead flow into the air reservoir.

Although the invention has been shown and described as having a vent passageway having an air restriction that comprises an orifice, it will be appreciated that many types of restrictions can be appropriately implemented. FIGS. 21A-C depict an inlet control mechanism **36s** in which the restriction is formed by a reduced diameter segment **256** of the vent passageway **118s**. Due to the extremely small relative diameter of the reduced diameter segment **256**, the segment **256**, like an orifice, greatly restricts the rate at which air can flow from the valve control chamber **92a** through the vent passageway **118s** to the valve outlet **102a**, thereby restricting the speed at which the piston assembly **96a** can move from the closed positions of FIGS. 21A and B toward to the open position of FIG. 21C.

FIGS. 22A and B depict an inlet control mechanism **36t** in which the vent passageway **118t** has a restriction comprising multiple orifices **122t** positioned in a series along the length of the valve stem **110t**. Each orifice **122t** of the configuration is identical to the other and each creates a successive air flow restriction reducing the downstream air pressure by roughly one order of magnitude. Thus the successive multiple orifices can be used to substantially increase the amount of time that is necessary for the valve piston assembly **96t** to move from a closed

position, as depicted in FIG. 22A, to a position that allows air to move from the valve inlet chamber **94t** to the valve outlet **102t**, as depicted in FIG. 22B.

FIGS. 23A and B depict an inlet control mechanism **36u** in which the vent passageway **118u** has a restriction comprising a porous metal restrictor **258** that is press fitted within the valve stem **110u**. The porous metal restrictor **258** is air permeable and allows a limited amount of air to pass therethrough, restricting airflow and reducing downstream air pressure accordingly. The effective magnitude of the restriction created can depend on the thickness or number of restrictors incorporated into the control mechanism **36u** and/or the exact type or permeability of the material used. Thus, the placement of the porous metal restrictor **258** can be used to substantially increase the amount of time that is necessary for the valve piston assembly **96u** to move from a closed position, as depicted in FIG. 23A, to a position that allows air to move from the valve inlet chamber **94u** to the valve outlet **102u**, as depicted in FIG. 23B.

FIGS. 24A and B depict an inlet control mechanism **36v** in which the vent passageway **118v** has a restriction comprising a labyrinth restrictor **260** that is press fitted into the vent passageway **118v** of the valve stem **110v**. Four different views of the labyrinth restrictor **260** are depicted in FIGS. 25A-D. The labyrinth restrictor **260** includes a plurality of flutes **264** extending along a reduced radius portion **262**, the reduced radius portion **262** being sized to allow for press fitting into a reduced diameter portion **266** of the vent passageway **118v**. When positioned within the reduced diameter portion **266** of the vent passageway **118v**, the flutes **264** and the inside walls of the vent passageway **118v** together form fluted passages allowing for the passage of air between the reduced diameter portion **266** and an expanded diameter portion **268** of the vent passageway **118v**.

The labyrinth restrictor **260** also includes an expanded radius portion **270** that is sized to allow a slight air clearance **272** to exist with the walls of the expanded diameter portion **268** of the vent passageway **118v** when installed within the valve stem **110v**. The expanded radius portion **270** of the restrictor **260** includes multiple grooves **274** that are incrementally spaced and positioned around the diameter of the expanded radius portion **270**. The flutes **264** of the reduced radius portion **266** of the restrictor **260** are open to the air

clearance **272** with the walls of the expanded diameter portion **268** of the vent passageway **118v** to allow air to bypass the restrictor **260** when it is installed within the valve stem **110v**. However, the close proximity of the expanded radius portion **270** of the restrictor **260** to the walls of the expanded diameter portion **268** of the vent passageway **118v** creates a restriction for passing air that has a restriction size allowing air to be drawn by the compressor unit at a preselected rate to cause the compressor unit to produce compressed air at less than its predetermined rate of production. Each groove **274** creates an air expansion space with the walls of the expanded diameter portion **268** of the vent passageway **118v**. As a result, each successive groove **274** creates a further, successive reduction in downstream air pressure. Where each successive groove **274** is of approximately equal size, each successive reduction in downstream air pressure will be of approximately one order of magnitude. Thus, the amount of time that is necessary for the valve piston assembly **96v** to move from a closed position, as depicted in FIG. 24A, to a position that allows air to move from the valve inlet chamber **94v** to the valve outlet **102v**, as depicted in FIG. 24B, can be determined by the respective size, shape/orientation, or number of grooves **274** that are included on the expanded radius portion **270** of the restrictor **260**.

FIGS. 26A-C depict an inlet control mechanism **36w** of the invention having a restriction comprising a restriction ball **276** positioned adjacent a diagonal orifice **278**. The restriction ball **276** is sized to allow air to pass between the restriction ball **276** and a ball chamber **279** of the vent passageway and allows a substantially greater amount of air to move between the vent passageway **118w** and valve control chamber **92w** than does the diagonal orifice **278** when the restriction ball **276** is not in contact a passageway cone **282**. The restriction ball **276** is biased with a ball spring **280** located within the ball chamber **279** to engage and seal against the passageway cone **282**. FIG. 26A depicts the inlet control mechanism **36w** in a closed position that prevents air from moving from the valve inlet chamber **94w** to the valve outlet **102w**. FIG. 26B depicts a magnified view of the restriction when in the closed position depicted in FIG. 26A.

Consider the inlet control mechanism **36w** prior to or at the start of operation of a compressor unit. As air begins to be drawn through the vent passageway **118w**, the combined biasing force of the ball spring **280** and the suction force of the compressor unit through the vent passageway **118w** force the restriction ball **276** against the passageway cone **282**, preventing the movement of air from the control chamber **92w** past the restriction ball **276** within the vent passageway **118w**. The suction force of the compressor unit does draw air through the diagonal orifice **278**. However, a comparatively small amount of air is permitted to move between the vent passageway **118w** and valve control chamber **92w** with the restriction ball **276** sealing against the passageway cone **282** due to the relatively small size of the diagonal orifice **278**. The diagonal orifice **278** continues to restrict the rate at which air can be drawn from the valve control chamber **92w** as the inlet control mechanism **36w** moves to an open position, such as the position depicted in FIG. 26C.

Now, referring to FIG. 26C, consider the inlet control mechanism **36w** as the compressor unit ceases operation. The valve inlet chamber **94w**, being open to the environment surrounding the compressor unit, allows air from the atmosphere to enter the vent passageway **118w** through the stem hole **120**. Atmospheric pressure in the vent passageway **118w** forces the restriction ball **276**, against the bias of the ball spring **280**, to move away from the passageway cone **282**. Since the restriction ball **276** is sized to allow for a substantially greater amount of air to move between the vent passageway **118w** and valve control chamber **92w** than does the diagonal orifice **278**, the movement of the restriction ball **276** away from passageway cone **282** allows air to enter the valve control chamber **92w** relatively quickly. This further allows the valve control chamber **92w** to quickly return to atmospheric pressure as the piston assembly **96w** moves back toward the valve inlet chamber **94w** under the force of the spring biasing member **114w**, eventually returning the inlet control mechanism **36w** to a closed position as depicted in FIG. 26A.

FIGS. 27A-C depict an inlet control mechanism **36x** of the invention having a restriction comprising a reciprocating orifice **284** positioned within an orifice chamber **286** that forms a segment of the vent passageway **118x**. The reciprocating orifice **284** is biased to rest against

passageway seals **288** with an orifice spring **290**. Air passages **292** allow for the unobstructed flow of air between the orifice chamber **286** and valve control chamber **92x**. The reciprocating orifice **284** is sized to allow a substantially smaller amount of air to pass through the vent passageway **118x** to the valve control chamber **92x** when the reciprocating orifice **284** is resting against the passageway seals **288** than when the force of air pushes the reciprocating orifice **284** against its bias away from the passageway seals **288**. FIG. 27A depicts the inlet control mechanism **36x** in a closed position that prevents air from moving from the valve inlet chamber **94x** to the valve outlet **102x**. FIG. 27B depicts a magnified view of the restriction when in the closed position depicted in FIG. 27A.

Consider the inlet control mechanism **36x** prior to or at the start of operation of a compressor unit. As air begins to be drawn through the vent passageway **118x** into the compression cylinder of the compressor unit, the combined biasing force of the orifice spring **290** and the suction force of the compressor unit through the vent passageway **118x** force the reciprocating orifice **284** against the passageway seals **288**, restricting the movement of air from the control chamber **92x** to the vent passageway **118x** through the reciprocating orifice **284**. However, due to the sizing of the reciprocating orifice **284**, the amount of air that is permitted to move through the reciprocating orifice **284** between valve control chamber **92x** and the vent passageway **118x** is substantially less than the amount that would be permitted if the reciprocating orifice **284** were withdrawn from contact with the passageway seals **288**. The reciprocating orifice **284** continues to restrict the rate at which air can be drawn from the valve control chamber **92x** as the inlet control mechanism **36x** moves to an open position, such as the position depicted in FIG. 27C.

Now, referring to FIG. 27C, consider the inlet control mechanism **36x** as the compressor unit ceases operation. The valve inlet chamber **94x**, being open to the environment surrounding the compressor unit, allows air from the atmosphere to enter the vent passageway **118x** through the stem hole **120**. Atmospheric pressure in the vent passageway **118x** forces the reciprocating orifice **284**, against the bias of the orifice spring **290**, to move away from the passageway seals **288**. Since a substantially greater amount of air can move between the vent

passageway **118x** and valve control chamber **92x** when the reciprocating orifice **284** is not in contact with the passageway seals **288** than when air is limited to movement through the reciprocating orifice **284**, air enters the valve control chamber **92x** from the vent passageway **118x** relatively quickly. This further allows the valve control chamber **92x** to quickly return to atmospheric pressure as the piston assembly **96x** moves back toward the valve inlet chamber **94x** under the force of the spring biasing member **114x**, eventually returning the inlet control mechanism **36x** to a closed position as depicted in FIG. 26A.

The invention can also be constructed to incorporate multiple, separately reciprocating members that act in concert to reduce compression loading. For example, FIGS. 28A-C depict an inlet control mechanism **36y** having a reciprocating tapered section **294** that is positioned to reciprocate within the valve inlet chamber **94y** and valve outlet **102y**. A separate piston assembly **96y** reciprocates between the valve inlet chamber **94y** and valve outlet chamber **92y**, the piston assembly **96y** including a valve stem **110y** that extends to the valve outlet **104y**. When the inlet control mechanism **36y** is in a closed position such as that depicted in FIG. 28A, the valve stem **110y** extends through the valve outlet hole **102y**. The valve stem **110y** also extends through a section hole **296** located at the narrow end of the reciprocating tapered section **294**. A section clip **298** is positioned to reciprocate with the valve stem **110y** and is configured to engage the narrow end of the reciprocating tapered section **294** near the section hole **296** when the inlet control mechanism **36y** is at a closed, intermediate position that is depicted in FIG. 28B. The section clip **298** is further configured to cause the reciprocating tapered section **294** to move with the valve piston assembly **96y** as it continues to move toward the valve control chamber **92y** to the open position depicted in FIG. 28C. The section clip **298** includes clip holes **300** that allow air to pass in a restricted manner through the section clip **298** from the valve inlet chamber **94y** to the valve outlet **102y** when the section clip **298** is in engagement with the reciprocating tapered section **294**.

Consider the inlet control mechanism **36y** prior to or at the start of operation of a compressor unit. As air begins to be drawn through the vent passageway **118y** from the valve control chamber **92y** into the compression cylinder of the compressor unit, the atmospheric

pressure in the valve inlet chamber **94y** begins to force the piston assembly **96y** toward the valve control chamber **92y**. Air is removed by the compressor pump from the valve outlet **102y** while atmospheric pressure from the valve inlet chamber **94y** is prevented from entering the valve outlet **102y** by the reciprocating tapered section **294**, the valve stem **110y**, and the valve stem seal **116y**. Although there is a resulting pressure differential that exists between the valve inlet chamber **94y** and the valve outlet **102y**, the reciprocating tapered section **294** does not move further toward the valve outlet hole **104y** past the position depicted in FIG. 28A since such movement is restricted by a section seat **302** positioned on the inside surface of the inlet segment **87y**.

As the piston assembly **96y** continues to move toward the valve control chamber **92y**, the valve stem seal **116y**, moving along the sliding surface **124**, continues to prevent air from moving from the valve inlet chamber **94y** to the valve outlet **102y** until the lip **126** of the valve stem **110y** withdraws the valve stem seal **116y** from its contact with the reciprocating tapered section **294**. Referring to FIG. 28B, this creates an air space **130y** between the valve stem seal **116y** and reciprocating tapered section **294**. The section clip **298** contacts the reciprocating tapered section **294** near the section hole **296**, but allows air to pass from the section hole **296** to the valve outlet **102y** through clip holes **300**. Air is therefore permitted to flow from the valve inlet chamber **94y** to the valve outlet **102y** when the inlet control mechanism **36y** is in the position depicted in FIG. 28B, the amount of air permitted to pass depending on the size and number of clip holes **300**.

As the piston assembly **96y** continues to move toward the valve control chamber **92y**, the section clip **298** forces the reciprocating tapered section **294** to withdraw from its contact with the section seat **302** toward the position depicted in FIG. 28C. As the piston assembly **96y** and reciprocating tapered section **294** move toward the valve control chamber **92y**, the movement is further restricted by the rate at which air is permitted to move through the clip holes **300**, increasing the amount of time required for the inlet control mechanism **36y** to move to the position depicted in FIG. 28A. Movement to this position opens the valve outlet **94y** to the valve inlet **98y**, thereby opening the valve outlet **102y** to atmospheric pressure and allowing air

from the environment to enter the compressor pump for compression. Thus, there is sequential opening of the sealing action that is created both by the valve stem seal **116y** and by the reciprocating tapered section **29** and section clip **298**.

By incorporating the additional actuation and reciprocation of the reciprocating tapered section **294**, the load of actuation is divided into smaller portions, distributing the total load more evenly through the stroke range of the valve piston assembly **96y**. This is due to the elimination of a need for a large pressure differential-created force at a single point in the stroke range of the valve piston **108y**. As a result, the inlet control mechanism **36y** can have a relatively small construction while performing the equivalent compression unloading of larger inlet control mechanisms.

It will be further appreciated that some embodiments of the invention allow for incorporation of an inlet control mechanism in which the valve inlet chamber, valve control chamber, portions of the valve cavity and/or other components are located in positions that are not located along a common valve axis. For example, FIGS. 29A and B depict a compressor pump **48za** of the invention having an automatic inlet control mechanism **36za** that includes a mechanism body **88za** integrated into the structure of the compressor pump **48za**.

The mechanism body **88za** includes a removable portion **304za** that is threaded to allow for removal and installation of components of the inlet control mechanism **36za** in the compressor pump **48za**. An external filter **166** is attached to a valve inlet **98za** leading to a valve inlet chamber **94za**. The valve inlet chamber **94za** is part of a valve cavity **90za** that extends from the valve inlet **98za** to a valve outlet hole **104za** and further includes a valve control chamber **92za**, vent passageway **308**, and atmosphere chamber **310za**. The atmosphere chamber **310za** is connected to the environment surrounding the inlet control mechanism **36za** with an atmosphere inlet **316** that is sufficiently large to maintain atmospheric pressure within the atmosphere chamber **310za**. The vent passageway **308** provides a route for the flow of air between the valve control chamber **92za** and valve outlet **102za** and includes an orifice **122za** to restrict airflow therein.

A valve piston assembly **96za** is positioned to reciprocate along a valve axis **312** and includes a valve piston **108za**, valve stem **108za**, and diaphragm **106**. The valve stem **108za** has an elongated cylindrical section **319za** that is sufficiently long to extend through a reduced diameter portion **318** of the valve cavity **90za** to a location that is between the valve inlet chamber **94za** and valve outlet **102za**. The elongated cylindrical section **319za** has a cylindrical shaped, reduced dimensional portion **320** that creates an air gap **322** with the adjacent valve cavity **90za**. The air gap **322** extends 360 degrees around the reduced dimensional portion **320** along a segment of the valve axis **312**. The valve piston **188za** and diaphragm **106** separate the valve control chamber **92za** from the atmosphere chamber **310za**, the diaphragm **106** forming a movable seal that prevents air from moving directly between the two chambers. The valve piston **188za** and valve piston assembly **96za** are biased with a biasing spring **314** to a closed position that is depicted in FIG. 29A. In this closed position, the valve stem **110za** extends between the inlet chamber **94za** and valve outlet **102za** to block the flow of air therebetween.

Consider the inlet control mechanism **36za** and compressor pump **48za** before or at the start of reciprocation of the piston **42**. As the piston **42** begins to reciprocate, air is quickly removed from the valve outlet **102za** and the cylindrical extension **319za** of the valve stem **110za** restricts air from the environment from entering the valve outlet **102za** from the valve inlet chamber **94za**. Air is drawn from the valve control chamber **92za** through the vent passageway **122za** and becomes the primary source of air to the compression cylinder **44**, though the amount of air that can be drawn is substantially restricted by the orifice **122za**, substantially reducing compression loading of piston **42**.

As air is drawn from the valve control chamber **92za** a pressure differential between the valve control chamber **92za** and atmosphere chamber **310za** forces the piston assembly **96za** away from the atmosphere chamber **310za** toward the open position depicted in FIG. 29B. However, the valve stem **110za** continues to restrict atmospheric pressure from the valve outlet **102za** from entering the valve inlet chamber **94za** until the reduced radius portion **320** of the

valve stem **110za** moves to a position that opens the air gap **322** to both the valve inlet chamber **94za** and valve outlet **102za**.

Once the valve stem **110za** moves to an open position, such as the position depicted in FIG. 29B, air is permitted to flow 360 degrees around the reduced radius portion **320** of valve stem **110za**, through the air gap **322**, to the valve outlet **102za**, restoring compression loading to the piston **42**. The biasing spring **314** returns the valve piston assembly **96zb** to the position depicted in FIG. 29A once the piston **42** ceases reciprocating within the compression cylinder **44**.

FIGS. 30 A and B depict a compressor pump **48zb** of the invention having an automatic inlet control mechanism **36zb** that includes a valve stem **110zb** having an air bore **324** extending through the elongated cylindrical extension **319zb** that allows air to pass through the valve stem **110zb** only when the inlet control mechanism **36zb** is in an open position. Before or at the time the piston **42** begins to reciprocate, the valve stem **110zb** is biased with the biasing spring **314** to the closed position depicted in FIG. 30A. In this position, the air bore **324** is not open to either the valve inlet chamber **94zb** or the valve outlet **102zb**, the cylindrical extension **319zb** of the valve stem **110zb** blocking the flow of air from the environment to the compression cylinder inlet **38zb**. However, as the piston **42** begins to reciprocate and draws air from the vent control chamber **92zb** through the vent passageway **308** and orifice **122zb**, the piston assembly **96zb** moves toward an open position, such as that depicted in FIG. 30B. In an open position, the air bore **324** moves to a location that is adjacent and open to both the valve inlet chamber **94zb** and the valve outlet **102zb**, allowing air to pass through the air bore **324** from the environment to the compression cylinder inlet **38zb** for compression. Once reciprocation of the piston **42** ceases, the biasing spring **314** moves the valve stem **319zb** back to the closed position depicted in FIG. 30A.

Those skilled in the art will recognize that the various features of this invention described above can be used in various combinations with other elements without departing from the scope of the invention. Thus, the appended claims are intended to be interpreted to

cover such equivalent air compressor units as do not depart from the spirit and scope of the invention.

**Claims**

1. An automatic inlet control mechanism for connection to a compression cylinder inlet of a reciprocating air compressor unit which produces compressed air at a predetermined rate of production through the use of a piston that reciprocates within a compression cylinder, said inlet control mechanism comprising:

a mechanism body having a valve cavity, said valve cavity having a valve control chamber and a valve inlet chamber, a valve piston assembly positioned between said valve control chamber and said valve inlet chamber and constructed to prevent air flow between said valve control chamber and said valve inlet chamber;

a valve inlet positioned to allow air to flow from the atmosphere surrounding the compressor unit and into said valve inlet chamber;

a valve outlet having a valve outlet hole positioned to allow air to flow from said valve inlet chamber to the compression cylinder inlet, said valve outlet hole having a size sufficient to enable the compressor unit to produce compressed air at its predetermined rate of production;

said valve piston assembly including a valve piston, said valve piston assembly being positioned to reciprocate within said valve cavity, a biasing member having a force which moves said valve piston assembly to a position within said inlet control mechanism which prevents air from flowing from said valve inlet chamber through said valve outlet when the compressor unit is not drawing air through said valve outlet;

a vent passageway allowing air to flow between said valve control chamber and the compression cylinder inlet;

said vent passageway comprising at least one source of air to the compression cylinder inlet for a period of time after the compressor unit begins to draw air through the compression cylinder inlet, following the movement of said valve piston assembly to a position which prevents air from flowing from said valve inlet chamber through said valve outlet to the compression cylinder inlet;

said vent passageway including a vent orifice which restricts the flow of air from said valve control chamber to said compression cylinder inlet; and

said vent orifice having an orifice size which allows air to be drawn, by the compressor unit, from said valve control chamber to the compression cylinder at a preselected rate which causes the compressor unit to produce compressed air at less than its predetermined rate of production, said valve control chamber having a volume which enables air to be drawn through said orifice from said valve control chamber by the compressor unit over a preselected time period until air within said valve control chamber is at a reduced pressure level which enables atmospheric pressure on said valve piston assembly from within said valve inlet chamber to overcome the force of said biasing member sufficiently to move said valve piston assembly away from the position at which said valve piston assembly prevents air from flowing from said valve inlet chamber and through said valve outlet to said compressor chamber inlet to enable the compressor unit to produce compressed air at its predetermined rate of production.

2. The automatic inlet control mechanism of claim 1 wherein said valve piston assembly includes a diaphragm positioned between said valve control chamber and said valve inlet chamber, said diaphragm being constructed to prevent air flow between said valve control chamber and said valve inlet chamber, said diaphragm being positioned to move toward said valve control chamber when air pressure within said valve inlet chamber is greater than air pressure within said valve control chamber, said diaphragm being positioned to move toward said valve inlet chamber when air pressure within said valve control chamber is greater than the air pressure within said valve inlet chamber.

3. The automatic inlet control mechanism of claim 1 wherein said vent passageway is included within said valve piston assembly, said vent orifice being located at a position in said valve piston assembly to enable said vent orifice to restrict the flow of air from said valve control chamber to the compression cylinder inlet as said valve piston assembly reciprocates within said inlet control mechanism.

4. The automatic inlet control mechanism of claim 1 wherein said valve piston assembly includes a valve stem, said vent passageway being included within said valve piston assembly and extending through said valve stem, said vent orifice being located at a position in said valve piston assembly to enable said vent orifice to restrict the flow of air from said valve

control chamber to the compression cylinder inlet as said valve piston assembly reciprocates within said inlet control mechanism.

5. The automatic inlet control mechanism of claim 1 wherein said valve outlet includes a valve outlet hole having a tapered portion, said tapered portion having at least a first inner diameter and a second inner diameter, said first inner diameter of said tapered portion being larger than said second inner diameter and being located at a position that is closer to said valve inlet chamber than said second inner diameter when said mechanism is installed, said second inner diameter being sufficiently small to form an air restriction against said valve piston assembly when said valve piston assembly is at a position within said inlet control mechanism which prevents air from flowing from said valve inlet chamber through said valve outlet, said first inner diameter of said tapered portion being sufficiently large to allow air to pass between said tapered portion of said valve outlet and said valve piston assembly when said valve piston assembly is at a position within said inlet control mechanism which allows air to flow from said valve inlet chamber through said valve outlet.

6. The automatic inlet control mechanism of claim 1 wherein said valve piston assembly includes a valve stem and a sliding seal mounted to reciprocate along at least a portion of said valve stem to contact said valve outlet to cause said valve piston assembly to prevent air from flowing from said valve inlet chamber through said valve outlet when the compressor unit is not drawing air through said valve outlet, the movement of said valve piston assembly away from the position at which said valve piston assembly prevents air from flowing from said valve inlet chamber and through said valve outlet to the compression cylinder inlet causing said sliding seal to move away from said valve outlet to allow air to flow to the compression cylinder inlet.

7. The automatic inlet control mechanism of claim 1 wherein said valve inlet includes a filter to remove impurities from air that passes through said valve inlet and enters said valve inlet chamber.

8. The automatic inlet control mechanism of claim 1 wherein said valve piston assembly includes a valve stem and a sliding seal mounted to reciprocate along at least a

portion of said valve stem to contact said valve outlet to cause said valve piston assembly to prevent air from flowing from said valve inlet chamber through said valve outlet when the compressor unit is not drawing air through said valve outlet, the movement of said valve piston assembly away from the position at which said valve piston assembly prevents air from flowing from said valve inlet chamber and through said valve outlet to the compression cylinder inlet causing said sliding seal to move away from said valve outlet to allow air to flow to the compression cylinder inlet, said valve inlet including a filter to remove impurities from air that passes through said valve inlet and enters said valve inlet chamber.

9. The automatic inlet control mechanism of claim 1 wherein the compression cylinder inlet includes a cylinder inlet chamber for receiving air from the compression cylinder inlet before the air enters the compression cylinder, said vent passageway being positioned to allow for air to flow, outside said valve piston assembly, directly between said valve control chamber and the cylinder inlet chamber.

10. The automatic inlet control mechanism of claim 1 wherein:

the compression cylinder inlet includes a cylinder inlet chamber for receiving air from the compression cylinder inlet before the air enters the compression cylinder, said vent passageway being positioned to allow for air to flow, outside said valve piston assembly, directly between said valve control chamber and the cylinder inlet chamber; and

said valve piston assembly includes a valve stem and a sliding seal mounted to reciprocate along at least a portion of said valve stem to contact said valve outlet to cause said valve piston assembly to prevent air from flowing from said valve inlet chamber through said valve outlet when the compressor unit is not drawing air through said valve outlet, the movement of said valve piston assembly away from the position at which said valve piston assembly prevents air from flowing from said valve inlet chamber and through said valve outlet to the compression cylinder inlet causing said sliding seal to move away from said valve outlet to allow air to flow to the compression cylinder inlet.

11. The automatic inlet control mechanism of claim 1 wherein the compression cylinder inlet includes a cylinder inlet chamber for receiving air before the air from the compression cylinder inlet enters the compression cylinder, said automatic inlet control mechanism being located at least partially within the cylinder inlet chamber.

12. The automatic inlet control mechanism of claim 1 wherein:

the compression cylinder inlet includes a cylinder inlet chamber for receiving air before the air from the compression cylinder inlet enters the compression cylinder, said automatic inlet control mechanism being located at least partially within the cylinder inlet chamber; and

said valve piston assembly includes a valve stem and a sliding seal mounted to reciprocate along at least a portion of said valve stem to contact said valve outlet to cause said valve piston assembly to prevent air from flowing from said valve inlet chamber through said valve outlet when the compressor unit is not drawing air through said valve outlet, the movement of said valve piston assembly away from the position at which said valve piston assembly prevents air from flowing from said valve inlet chamber and through said valve outlet to the compression cylinder inlet causing said sliding seal to move away from said valve outlet to allow air to flow to the compression cylinder inlet.

13. The automatic inlet control mechanism of claim 1 wherein:

the compression cylinder inlet includes a cylinder inlet chamber for receiving air before the air from the compression cylinder inlet enters the compression cylinder, an inlet hole being positioned between the cylinder inlet chamber and the compression cylinder to channel air from the compression cylinder inlet to the compression cylinder, the inlet hole having an inlet valve to prevent the movement of air from the compression cylinder back through the inlet hole when the piston compresses air with a compression stroke, the air compressor unit including a compression cylinder outlet for receiving air that has been compressed by the compression cylinder and an outlet hole for channeling air from the compression cylinder into the outlet chamber, the outlet hole having an outlet valve to prevent the movement of air from the outlet chamber back through the outlet hole when the piston draws air through the inlet hole with an intake stroke, the automatic inlet control further comprising:

a vent valve extending between the cylinder inlet chamber and the compressor outlet chamber, said vent valve having an open position in which said vent valve allows air to pass between the cylinder inlet chamber and the compressor outlet chamber and said vent valve having a closed position in which said vent valve prevents air from passing between the cylinder inlet chamber and the compressor outlet chamber, said vent valve being biased to the closed position; and

a valve stem mounted on said valve piston assembly, said valve stem extending into the cylinder inlet chamber, said valve stem being constructed and positioned to engage and move said vent valve to the open position when said valve piston assembly is in a position within said inlet control mechanism that prevents air from flowing from said valve inlet chamber through said valve outlet, said valve stem being positioned to disengage the vent valve and allow said vent valve to move to said closed position when said valve piston assembly is in a position within said inlet control mechanism that allows air to flow from said valve inlet chamber through said valve outlet.

14. The automatic inlet control mechanism of claim 1 further comprising an adjustment mechanism, said adjustment mechanism having a plurality of adjustment positions, each said adjustment position allowing said valve piston assembly to move to one of a plurality of open positions within said inlet control mechanism, each of said plurality of open positions allowing a separate predetermined amount of air to flow from said valve inlet chamber through said valve outlet during each piston reciprocation of the air compressor unit.

15. The automatic inlet control mechanism of claim 1 wherein the compressor unit includes an air reservoir, said automatic inlet control mechanism further comprising:

an equalization passage extending from the atmosphere surrounding said automatic inlet control to said valve control chamber; and

an equalization valve having an open position and a closed position, said equalization valve being responsive to the air pressure contained within the air reservoir and allowing air to flow through said equalization passage between the atmosphere and said valve control chamber when said equalization valve is in said open position, said equalization valve

preventing air from flowing between the atmosphere surrounding said inlet control and said valve control chamber when said equalization valve is in said closed position, said equalization valve moving to said closed position when the air pressure within the air reservoir falls below a predetermined minimum magnitude, said equalization valve moving to said open position when the air pressure within the air reservoir rises above a predetermined maximum magnitude.

16. The automatic inlet control mechanism of claim 1 wherein the compressor unit includes an air reservoir, a discharge tube to channel air from the compression cylinder to the air reservoir, an outlet valve to prevent air from flowing from the discharge tube back into the compression cylinder, and a check valve to prevent air from flowing from the air reservoir back into the discharge tube, said automatic inlet control mechanism further comprising:

a bleed passage extending between the discharge tube and said valve inlet chamber;

a bleed valve having an open position and a closed position, said bleed valve being biased to said closed position, said bleed valve allowing air to flow between the discharge tube and said valve inlet chamber when said bleed valve is in the open position, said bleed valve preventing air from flowing between the discharge tube and said valve inlet chamber when said bleed valve is in the closed position; and

a bleed pin mounted on said valve piston assembly, said bleed pin being positioned to reciprocate with said valve piston assembly within said inlet control mechanism, said bleed pin being configured to engage and move said bleed valve to said open position when said valve piston assembly is in a position within said inlet control mechanism that prevents air from flowing from said valve inlet chamber through said valve outlet, said bleed pin being positioned to disengage said bleed valve and allow said bleed valve to move to said closed position when said valve piston assembly is in a position within said inlet control mechanism that allows air to flow from said valve inlet chamber through said valve outlet.

17. An automatic inlet control mechanism for connection to a compression cylinder inlet of a reciprocating air compressor unit which produces compressed air at a predetermined rate of production through the use of a piston that reciprocates within a compression cylinder, said inlet control mechanism comprising:

a mechanism body having a valve cavity, said valve cavity having a valve control chamber and a valve inlet chamber, a valve piston assembly positioned between said valve control chamber and said valve inlet chamber and constructed to prevent air flow between said valve control chamber and said valve inlet chamber;

a valve inlet positioned to allow air to flow from the atmosphere surrounding the compressor unit and into said valve inlet chamber;

a valve outlet having a valve outlet hole positioned to allow air to flow from said valve inlet chamber to the compression cylinder inlet, said valve outlet hole having a size sufficient to enable the compressor unit to produce compressed air at its predetermined rate of production;

said valve piston assembly including a valve piston, said valve piston assembly being positioned to reciprocate within said valve cavity, a biasing member having a force which moves said valve piston assembly to a position within said inlet control mechanism which prevents air from flowing from said valve inlet chamber through said valve outlet when the compressor unit is not drawing air through said valve outlet;

a vent passageway allowing air to flow between said valve control chamber and the compression cylinder inlet;

said vent passageway comprising the primary source of air to the compression cylinder inlet for the period of time after the compressor unit begins to draw air through the compression cylinder inlet following the movement of said valve piston assembly to the position which prevents air from flowing from said valve inlet chamber through said valve outlet;

said vent passageway including a vent orifice which restricts the flow of air from said valve control chamber to said compression cylinder inlet; and

said vent orifice having an orifice size which allows air to be drawn, by the compressor unit, from said valve control chamber to the compression cylinder at a preselected rate which causes the compressor unit to produce compressed air at less than its predetermined rate of production, said valve control chamber having a volume which enables air to be drawn through said orifice from said valve control chamber by the compressor unit over a preselected time period until air within said valve control chamber is at a reduced pressure level which enables

atmospheric pressure on said valve piston assembly from within said valve inlet chamber to overcome the force of said biasing member sufficiently to move said valve piston assembly away from the position at which said valve piston assembly prevents air from flowing from said valve inlet chamber and through said valve outlet to said compressor chamber inlet to enable the compressor unit to produce compressed air at its predetermined rate of production.

18. The automatic inlet control mechanism of claim 17 wherein said valve piston assembly includes a diaphragm positioned between said valve control chamber and said valve inlet chamber, said diaphragm being constructed to prevent air flow between said valve control chamber and said valve inlet chamber, said diaphragm being positioned to move toward said valve control chamber when air pressure within said valve inlet chamber is greater than air pressure within said valve control chamber, said diaphragm being positioned to move toward said valve inlet chamber when air pressure within said valve control chamber is greater than the air pressure within said valve inlet chamber.

19. The automatic inlet control mechanism of claim 17 wherein said vent passageway is included within said valve piston assembly, said vent orifice being located at a position in said valve piston assembly to enable said vent orifice to restrict the flow of air from said valve control chamber to the compression cylinder inlet as said valve piston assembly reciprocates within said inlet control mechanism.

20. The automatic inlet control mechanism of claim 17 wherein said valve piston assembly includes a valve stem, said vent passageway being included within said valve piston assembly and extending through said valve stem, said vent orifice being located at a position in said valve piston assembly to enable said vent orifice to restrict the flow of air from said valve control chamber to the compression cylinder inlet as said valve piston assembly reciprocates within said inlet control mechanism.

21. The automatic inlet control mechanism of claim 17 wherein said valve outlet includes a valve outlet hole having a tapered portion, said tapered portion having at least a first inner diameter and a second inner diameter, said first inner diameter of said tapered portion being larger than said second inner diameter and being located at a position that is closer to

said valve inlet chamber than said second inner diameter when said mechanism is installed, said second inner diameter being sufficiently small to form an air restriction against said valve piston assembly when said valve piston assembly is at a position within said inlet control mechanism which prevents air from flowing from said valve inlet chamber through said valve outlet, said first inner diameter of said tapered portion being sufficiently large to allow air to pass between said tapered portion of said valve outlet and said valve piston assembly when said valve piston assembly is at a position within said inlet control mechanism which allows air to flow from said valve inlet chamber through said valve outlet.

22. The automatic inlet control mechanism of claim 17 wherein said valve piston assembly includes a valve stem and a sliding seal mounted to reciprocate along at least a portion of said valve stem to contact said valve outlet to cause said valve piston assembly to prevent air from flowing from said valve inlet chamber through said valve outlet when the compressor unit is not drawing air through said valve outlet, the movement of said valve piston assembly away from the position at which said valve piston assembly prevents air from flowing from said valve inlet chamber and through said valve outlet to the compression cylinder inlet causing said sliding seal to move away from said valve outlet to allow air to flow to the compression cylinder inlet.

23. The automatic inlet control mechanism of claim 17 wherein said valve inlet includes a filter to remove impurities from air that passes through said valve inlet and enters said valve inlet chamber.

24. The automatic inlet control mechanism of claim 17 wherein said valve piston assembly includes a valve stem and a sliding seal mounted to reciprocate along at least a portion of said valve stem to contact said valve outlet to cause said valve piston assembly to prevent air from flowing from said valve inlet chamber through said valve outlet when the compressor unit is not drawing air through said valve outlet, the movement of said valve piston assembly away from the position at which said valve piston assembly prevents air from flowing from said valve inlet chamber and through said valve outlet to the compression cylinder inlet causing said sliding seal to move away from said valve outlet to allow air to flow to the

compression cylinder inlet, said valve inlet including a filter to remove impurities from air that passes through said valve inlet and enters said valve inlet chamber.

25. The automatic inlet control mechanism of claim 17 wherein the compression cylinder inlet includes a cylinder inlet chamber for receiving air from the compression cylinder inlet before the air enters the compression cylinder, said vent passageway being positioned to allow for air to flow, outside said valve piston assembly, directly between said valve control chamber and the cylinder inlet chamber.

26. The automatic inlet control mechanism of claim 17 wherein:

the compression cylinder inlet includes a cylinder inlet chamber for receiving air from the compression cylinder inlet before the air enters the compression cylinder, said vent passageway being positioned to allow for air to flow, outside said valve piston assembly, directly between said valve control chamber and the cylinder inlet chamber; and

said valve piston assembly includes a valve stem and a sliding seal mounted to reciprocate along at least a portion of said valve stem to contact said valve outlet to cause said valve piston assembly to prevent air from flowing from said valve inlet chamber through said valve outlet when the compressor unit is not drawing air through said valve outlet, the movement of said valve piston assembly away from the position at which said valve piston assembly prevents air from flowing from said valve inlet chamber and through said valve outlet to the compression cylinder inlet causing said sliding seal to move away from said valve outlet to allow air to flow to the compression cylinder inlet.

27. The automatic inlet control mechanism of claim 17 wherein the compression cylinder inlet includes a cylinder inlet chamber for receiving air before the air from the compression cylinder inlet enters the compression cylinder, said automatic inlet control mechanism being located at least partially within the cylinder inlet chamber.

28. The automatic inlet control mechanism of claim 17 wherein:

the compression cylinder inlet includes a cylinder inlet chamber for receiving air before the air from the compression cylinder inlet enters the compression cylinder, said automatic inlet control mechanism being located at least partially within the cylinder inlet chamber; and

said valve piston assembly includes a valve stem and a sliding seal mounted to reciprocate along at least a portion of said valve stem to contact said valve outlet to cause said valve piston assembly to prevent air from flowing from said valve inlet chamber through said valve outlet when the compressor unit is not drawing air through said valve outlet, the movement of said valve piston assembly away from the position at which said valve piston assembly prevents air from flowing from said valve inlet chamber and through said valve outlet to the compression cylinder inlet causing said sliding seal to move away from said valve outlet to allow air to flow to the compression cylinder inlet.

29. The automatic inlet control mechanism of claim 17 wherein:

the compression cylinder inlet includes a cylinder inlet chamber for receiving air before the air from the compression cylinder inlet enters the compression cylinder, an inlet hole being positioned between the cylinder inlet chamber and the compression cylinder to channel air from the compression cylinder inlet to the compression cylinder, the inlet hole having an inlet valve to prevent the movement of air from the compression cylinder back through the inlet hole when the piston compresses air with a compression stroke, the air compressor unit including a compression cylinder outlet for receiving air that has been compressed by the compression cylinder and an outlet hole for channeling air from the compression cylinder into the outlet chamber, the outlet hole having an outlet valve to prevent the movement of air from the outlet chamber back through the outlet hole when the piston draws air through the inlet hole with an intake stroke, the automatic inlet control further comprising:

a vent valve extending between the cylinder inlet chamber and the compressor outlet chamber, said vent valve having an open position in which said vent valve allows air to pass between the cylinder inlet chamber and the compressor outlet chamber and said vent valve having a closed position in which said vent valve prevents air from passing between the cylinder inlet chamber and the compressor outlet chamber, said vent valve being biased to the closed position; and

a valve stem mounted on said valve piston assembly, said valve stem extending into the cylinder inlet chamber, said valve stem being constructed and positioned to engage and move

said vent valve to the open position when said valve piston assembly is in a position within said inlet control mechanism that prevents air from flowing from said valve inlet chamber through said valve outlet, said valve stem being positioned to disengage the vent valve and allow said vent valve to move to said closed position when said valve piston assembly is in a position within said inlet control mechanism that allows air to flow from said valve inlet chamber through said valve outlet.

30. The automatic inlet control mechanism of claim 17 further comprising an adjustment mechanism, said adjustment mechanism having a plurality of adjustment positions, each said adjustment position allowing said valve piston assembly to move to one of a plurality of open positions within said inlet control mechanism, each of said plurality of open positions allowing a separate predetermined amount of air to flow from said valve inlet chamber through said valve outlet during each piston reciprocation of the air compressor unit.

31. The automatic inlet control mechanism of claim 17 wherein the compressor unit includes an air reservoir, said automatic inlet control mechanism further comprising:

an equalization passage extending from the atmosphere surrounding said automatic inlet control to said valve control chamber; and

an equalization valve having an open position and a closed position, said equalization valve being responsive to the air pressure contained within the air reservoir and allowing air to flow through said equalization passage between the atmosphere and said valve control chamber when said equalization valve is in said open position, said equalization valve preventing air from flowing between the atmosphere surrounding said inlet control and said valve control chamber when said equalization valve is in said closed position, said equalization valve moving to said closed position when the air pressure within the air reservoir falls below a predetermined minimum magnitude, said equalization valve moving to said open position when the air pressure within the air reservoir rises above a predetermined maximum magnitude.

32. The automatic inlet control mechanism of claim 17 wherein the compressor unit includes an air reservoir, a discharge tube to channel air from the compression cylinder to the air reservoir, an outlet valve to prevent air from flowing from the discharge tube back into the

compression cylinder, and a check valve to prevent air from flowing from the air reservoir back into the discharge tube, said automatic inlet control mechanism further comprising:

a bleed passage extending between the discharge tube and said valve inlet chamber;

a bleed valve having an open position and a closed position, said bleed valve being biased to said closed position, said bleed valve allowing air to flow between the discharge tube and said valve inlet chamber when said bleed valve is in the open position, said bleed valve preventing air from flowing between the discharge tube and said valve inlet chamber when said bleed valve is in the closed position; and

a bleed pin mounted on said valve piston assembly, said bleed pin being positioned to reciprocate with said valve piston assembly within said inlet control mechanism, said bleed pin being configured to engage and move said bleed valve to said open position when said valve piston assembly is in a position within said inlet control mechanism that prevents air from flowing from said valve inlet chamber through said valve outlet, said bleed pin being positioned to disengage said bleed valve and allow said bleed valve to move to said closed position when said valve piston assembly is in a position within said inlet control mechanism that allows air to flow from said valve inlet chamber through said valve outlet.

33. An automatic inlet control mechanism for connection to a compression cylinder inlet of a reciprocating air compressor unit which produces compressed air at a predetermined rate of production through the use of a piston that reciprocates within a compression cylinder, said inlet control mechanism comprising:

a mechanism body having a valve cavity, said valve cavity having a valve control chamber and a valve inlet chamber, a valve piston assembly positioned between said valve control chamber and said valve inlet chamber and constructed to prevent air flow between said valve control chamber and said valve inlet chamber, said valve piston assembly including a diaphragm positioned between said valve control chamber and said valve inlet chamber, said diaphragm being constructed to prevent air flow between said valve control chamber and said valve inlet chamber, said diaphragm being positioned to move toward said valve control chamber when air pressure within said valve inlet chamber is greater than air pressure within

said valve control chamber, said diaphragm being positioned to move toward said valve inlet chamber when air pressure within said valve control chamber is greater than the air pressure within said valve inlet chamber;

a valve inlet positioned to allow air to flow from the atmosphere surrounding the compressor unit and into said valve inlet chamber;

a valve outlet having a valve outlet hole positioned to allow air to flow from said valve inlet chamber to the compression cylinder inlet, said valve outlet hole having a size sufficient to enable the compressor unit to produce compressed air at its predetermined rate of production;

a valve piston and a valve stem included in said valve piston assembly, said valve piston assembly being positioned to reciprocate within said valve cavity, a biasing member having a force which moves said valve piston assembly to a position within said inlet control mechanism which prevents air from flowing from said valve inlet chamber through said valve outlet when the compressor unit is not drawing air through said valve outlet;

a vent passageway included in said valve piston assembly, said vent passageway allowing air to flow between said valve control chamber and the compression cylinder inlet;

said vent passageway comprising at least one source of air to the compression cylinder inlet for a period of time after the compressor unit begins to draw air through the compression cylinder inlet, following the movement of said valve piston assembly to a position which prevents air from flowing from said valve inlet chamber through said valve outlet to the compression cylinder inlet;

a valve outlet hole having a tapered portion included in said valve outlet, said tapered portion having a first inner diameter and a second inner diameter, said first inner diameter of said tapered portion being larger than said second inner diameter and being located at a position that is closer to said valve inlet chamber than said second inner diameter when said inlet control mechanism is installed, said second inner diameter being sufficiently small to form an air restriction against said valve piston assembly when said valve piston assembly is at a position within said inlet control mechanism which prevents air from flowing from said valve inlet chamber through said valve outlet, said first inner diameter of said tapered portion being

sufficiently large to allow air to pass between said tapered portion of said valve outlet hole and said valve piston assembly when said valve piston assembly is at a position within said inlet control mechanism which allows air to flow from said valve inlet chamber through said valve outlet; and

said vent passageway including a vent orifice which restricts the flow of air from said valve control chamber to said compression cylinder inlet; and

said vent orifice having an orifice size which allows air to be drawn by the compressor unit from said valve control chamber to the compression cylinder at a preselected rate which causes the compressor unit to produce compressed air at less than its predetermined rate of production, said valve control chamber having a volume which enables air to be drawn through said orifice from said valve control chamber by the compressor unit over a preselected time period until air within said valve control chamber is at a reduced pressure level which enables atmospheric pressure on the valve piston assembly from within the valve inlet chamber to overcome the force of said biasing member sufficiently to move said valve piston assembly away from the position at which said valve piston assembly prevents air from flowing from said valve inlet chamber through said valve outlet to enable the compressor unit to produce compressed air at its predetermined rate of production.

34. The automatic inlet control mechanism of claim 33 wherein said valve piston assembly includes a valve stem and a sliding seal mounted to reciprocate along at least a portion of said valve stem to contact said valve outlet to cause said valve piston assembly to prevent air from flowing from said valve inlet chamber through said valve outlet when the compressor unit is not drawing air through said valve outlet, the movement of said valve piston assembly away from the position at which said valve piston assembly prevents air from flowing from said valve inlet chamber and through said valve outlet to the compression cylinder inlet causing said sliding seal to move away from said valve outlet to allow air to flow to the compression cylinder inlet.

35. The automatic inlet control mechanism of claim 33 wherein said valve inlet includes a filter to remove impurities from air that passes through said valve inlet and enters said valve inlet chamber.

36. The automatic inlet control mechanism of claim 33 wherein said valve piston assembly includes a valve stem and a sliding seal mounted to reciprocate along at least a portion of said valve stem to contact said valve outlet to cause said valve piston assembly to prevent air from flowing from said valve inlet chamber through said valve outlet when the compressor unit is not drawing air through said valve outlet, the movement of said valve piston assembly away from the position at which said valve piston assembly prevents air from flowing from said valve inlet chamber and through said valve outlet to the compression cylinder inlet causing said sliding seal to move away from said valve outlet to allow air to flow to the compression cylinder inlet, said valve inlet including a filter to remove impurities from air that passes through said valve inlet and enters said valve inlet chamber.

37. An automatic inlet control mechanism for connection to a compression cylinder inlet of a reciprocating air compressor unit which produces compressed air at a predetermined rate of production through the use of a piston that reciprocates within a compression cylinder, said inlet control mechanism comprising:

a mechanism body having a valve cavity, said valve cavity having a valve control chamber and a valve inlet chamber, a valve piston assembly positioned between said valve control chamber and said valve inlet chamber and constructed to prevent air flow between said valve control chamber and said valve inlet chamber, said valve piston assembly including a diaphragm positioned between said valve control chamber and said valve inlet chamber, said diaphragm being constructed to prevent air flow between said valve control chamber and said valve inlet chamber, said diaphragm being positioned to move toward said valve control chamber when air pressure within said valve inlet chamber is greater than air pressure within said valve control chamber, said diaphragm being positioned to move toward said valve inlet chamber when air pressure within said valve control chamber is greater than the air pressure within said valve inlet chamber;

a valve inlet positioned to allow air to flow from the atmosphere surrounding the compressor unit and into said valve inlet chamber;

a valve outlet having a valve outlet hole positioned to allow air to flow from said valve inlet chamber to the compression cylinder inlet, said valve outlet hole having a size sufficient to enable the compressor unit to produce compressed air at its predetermined rate of production;

a valve piston and a valve stem included in said valve piston assembly, said valve piston assembly being positioned to reciprocate within said valve cavity, a biasing member having a force which moves said valve piston assembly to a position within said inlet control mechanism which prevents air from flowing from said valve inlet chamber through said valve outlet when the compressor unit is not drawing air through said valve outlet;

a vent passageway included in said valve piston assembly, said vent passageway allowing air to flow between said valve control chamber and the compression cylinder inlet;

said vent passageway comprising the primary source of air to the compression cylinder inlet for a period of time after the compressor unit begins to draw air through the compression cylinder inlet, following the movement of said valve piston assembly to a position which prevents air from flowing from said valve inlet chamber through said valve outlet to the compression cylinder inlet;

a valve outlet hole having a tapered portion included in said valve outlet, said tapered portion having a first inner diameter and a second inner diameter, said first inner diameter of said tapered portion being larger than said second inner diameter and being located at a position that is closer to said valve inlet chamber than said second inner diameter when said inlet control mechanism is installed, said second inner diameter being sufficiently small to form an air restriction against said valve piston assembly when said valve piston assembly is at a position within said inlet control mechanism which prevents air from flowing from said valve inlet chamber through said valve outlet, said first inner diameter of said tapered portion being sufficiently large to allow air to pass between said tapered portion of said valve outlet hole and said valve piston assembly when said valve piston assembly is at a position within said inlet

control mechanism which allows air to flow from said valve inlet chamber through said valve outlet;

said vent passageway including a vent orifice which restricts the flow of air from said valve control chamber to said compression cylinder inlet; and

said vent orifice having an orifice size which allows air to be drawn by the compressor unit from said valve control chamber to the compression cylinder at a preselected rate which causes the compressor unit to produce compressed air at less than its predetermined rate of production, said valve control chamber having a volume which enables air to be drawn through said orifice from said valve control chamber by the compressor unit over a preselected time period until air within said valve control chamber is at a reduced pressure level which enables atmospheric pressure on the valve piston assembly from within the valve inlet chamber to overcome the force of said biasing member sufficiently to move said valve piston assembly away from the position at which said valve piston assembly prevents air from flowing from said valve inlet chamber through said valve outlet to enable the compressor unit to produce compressed air at its predetermined rate of production.

38. The automatic inlet control mechanism of claim 37 wherein said valve piston assembly includes a valve stem and a sliding seal mounted to reciprocate along at least a portion of said valve stem to contact said valve outlet to cause said valve piston assembly to prevent air from flowing from said valve inlet chamber through said valve outlet when the compressor unit is not drawing air through said valve outlet, the movement of said valve piston assembly away from the position at which said valve piston assembly prevents air from flowing from said valve inlet chamber and through said valve outlet to the compression cylinder inlet causing said sliding seal to move away from said valve outlet to allow air to flow to the compression cylinder inlet.

39. The automatic inlet control mechanism of claim 37 wherein said valve inlet includes a filter to remove impurities from air that passes through said valve inlet and enters said valve inlet chamber.

40. The automatic inlet control mechanism of claim 37 wherein said valve piston assembly includes a valve stem and a sliding seal mounted to reciprocate along at least a portion of said valve stem to contact said valve outlet to cause said valve piston assembly to prevent air from flowing from said valve inlet chamber through said valve outlet when the compressor unit is not drawing air through said valve outlet, the movement of said valve piston assembly away from the position at which said valve piston assembly prevents air from flowing from said valve inlet chamber and through said valve outlet to the compression cylinder inlet causing said sliding seal to move away from said valve outlet to allow air to flow to the compression cylinder inlet, said valve inlet including a filter to remove impurities from air that passes through said valve inlet and enters said valve inlet chamber.

41. A reciprocating air compressor unit which produces compressed air at a predetermined rate of production through the use of a piston that reciprocates within a compression cylinder, said air compressor unit comprising:

an automatic inlet control mechanism for connection to said compression cylinder inlet, said automatic inlet control having a mechanism body having a valve cavity, said valve cavity having a valve control chamber and a valve inlet chamber, a valve piston assembly positioned between said valve control chamber and said valve inlet chamber and constructed to prevent air flow between said valve control chamber and said valve inlet chamber;

a valve inlet positioned to allow air to flow from the atmosphere surrounding said compressor unit and into said valve inlet chamber;

a valve outlet having a valve outlet hole positioned to allow air to flow from said valve inlet chamber to said compression cylinder inlet, said valve outlet hole having a size sufficient to enable said compressor unit to produce compressed air at its predetermined rate of production;

said valve piston assembly including a valve piston and a valve stem, said valve piston assembly being positioned to reciprocate within said valve cavity, a biasing member having a force which moves said valve piston assembly to a position within said inlet control mechanism

which prevents air from flowing from said valve inlet chamber through said valve outlet when said compressor unit is not drawing air through said valve outlet;

a vent passageway allowing air to flow between said valve control chamber and said compression cylinder inlet;

said vent passageway comprising at least one source of air to said compression cylinder inlet for a period of time after said compressor unit begins to draw air through said compression cylinder inlet, following the movement of said valve piston assembly to a position which prevents air from flowing from said valve inlet chamber through said valve outlet to the compression cylinder inlet;

said vent passageway including a vent orifice which restricts the flow of air from said valve control chamber to said compression cylinder inlet; and

said vent orifice having an orifice size which allows air to be drawn, by the compressor unit, from said valve control chamber to said compression cylinder at a preselected rate which causes said compressor unit to produce compressed air at less than its predetermined rate of production, said valve control chamber having a volume which enables air to be drawn through said orifice from said valve control chamber by said compressor unit over a preselected time period until air within said valve control chamber is at a reduced pressure level which enables atmospheric pressure on said valve piston assembly from within said valve inlet chamber to overcome the force of said biasing member sufficiently to move said valve piston assembly away from said position at which said valve piston assembly prevents air from flowing from said valve inlet chamber and through said valve outlet to said compression cylinder inlet enable said compressor unit to produce compressed air at its predetermined rate of production.

42. The reciprocating air compressor unit of claim 41 wherein said valve piston assembly includes a diaphragm positioned between said valve control chamber and said valve inlet chamber, said diaphragm being constructed to prevent air flow between said valve control chamber and said valve inlet chamber, said diaphragm being positioned to move toward said valve control chamber when air pressure within said valve inlet chamber is greater than air pressure within said valve control chamber, said diaphragm being positioned to move toward

said valve inlet chamber when air pressure within said valve control chamber is greater than the air pressure within said valve inlet chamber.

43. The reciprocating air compressor unit of claim 41 wherein said vent passageway is included within said valve piston assembly, said vent orifice being located at a position in said valve piston assembly to enable said vent orifice to restrict the flow of air from said valve control chamber to said compression cylinder inlet as said valve piston assembly reciprocates within said inlet control mechanism.

44. The reciprocating air compressor unit of claim 41 wherein said valve piston assembly includes a valve stem, said vent passageway is included within said valve piston assembly and extends through said valve stem, said vent orifice being located at a position in said piston assembly to enable said vent orifice to restrict the flow of air from said valve control chamber to said compression cylinder inlet as said piston assembly reciprocates within said inlet control mechanism.

45. The reciprocating air compressor unit of claim 41 wherein said valve outlet includes a valve outlet hole having a tapered portion, said tapered portion having at least a first inner diameter and a second inner diameter, said first inner diameter of said tapered portion being larger than said second inner diameter and being located at a position that is closer to said valve inlet chamber than said second inner diameter, said second inner diameter being sufficiently small to form an air restriction against said valve piston assembly when said valve piston assembly is at a position within said inlet control mechanism which prevents air from flowing from said valve inlet chamber through said valve outlet, said first inner diameter of said tapered portion being sufficiently large to allow air to pass between said tapered portion of said valve outlet and said valve piston assembly when said valve piston assembly is at a position within said inlet control mechanism which allows air to flow from said valve inlet chamber through said valve outlet.

46. The reciprocating air compressor unit of claim 41 wherein said valve piston assembly includes a valve stem and a sliding seal mounted to reciprocate along at least a portion of said valve stem to contact said valve outlet to cause said valve piston assembly to

prevent air from flowing from said valve inlet chamber through said valve outlet when the compressor unit is not drawing air through said valve outlet, the movement of said valve piston assembly away from the position at which said valve piston assembly prevents air from flowing from said valve inlet chamber and through said valve outlet to said compression cylinder inlet causing said sliding seal to move away from said valve outlet to allow air to flow to said compression cylinder inlet.

47. The reciprocating air compressor unit of claim 41 wherein said valve inlet includes a filter to remove impurities from air that passes through said valve inlet and enters said valve inlet chamber.

48. The reciprocating air compressor unit of claim 41 wherein said valve piston assembly includes a valve stem and a sliding seal mounted to reciprocate along at least a portion of said valve stem to contact said valve outlet to cause said valve piston assembly to prevent air from flowing from said valve inlet chamber through said valve outlet when the compressor unit is not drawing air through said valve outlet, the movement of said valve piston assembly away from the position at which said valve piston assembly prevents air from flowing from said valve inlet chamber and through said valve outlet to said compression cylinder inlet causing said sliding seal to move away from said valve outlet to allow air to flow to said compression cylinder inlet, said valve inlet including a filter to remove impurities from air that passes through said valve inlet and enters said valve inlet chamber.

49. The reciprocating air compressor unit of claim 41 wherein said compression cylinder inlet includes a cylinder inlet chamber for receiving air from said compression cylinder inlet before the air enters said compression cylinder, said vent passageway being positioned to allow for air to flow, outside said valve piston assembly, directly between said valve control chamber and said cylinder inlet chamber.

50. The reciprocating air compressor unit of claim 41 wherein:  
said compression cylinder inlet includes a cylinder inlet chamber for receiving air from said compression cylinder inlet before the air enters said compression cylinder, said vent

passageway being positioned to allow for air to flow, outside said valve piston assembly, directly between said valve control chamber and said cylinder inlet chamber; and

said valve piston assembly includes a valve stem and a sliding seal mounted to reciprocate along at least a portion of said valve stem to contact said valve outlet to cause said valve piston assembly to prevent air from flowing from said valve inlet chamber through said valve outlet when said compressor unit is not drawing air through said valve outlet, the movement of said valve piston assembly away from the position at which said valve piston assembly prevents air from flowing from said valve inlet chamber and through said valve outlet to said compression cylinder inlet causing said sliding seal to move away from said valve outlet to allow air to flow to said compression cylinder inlet.

51. The reciprocating air compressor unit of claim 41 wherein said compression cylinder inlet includes a cylinder inlet chamber for receiving air before the air from said compression cylinder inlet enters said compression cylinder, said automatic inlet control mechanism being located at least partially within said cylinder inlet chamber.

52. The reciprocating air compressor unit of claim 41 wherein:

said compression cylinder inlet includes a cylinder inlet chamber for receiving air before the air from said compression cylinder inlet enters said compression cylinder, said automatic inlet control mechanism being located at least partially within said cylinder inlet chamber; and

said valve piston assembly includes a valve stem and a sliding seal mounted to reciprocate along at least a portion of said valve stem to contact said valve outlet to cause said valve piston assembly to prevent air from flowing from said valve inlet chamber through said valve outlet when the compressor unit is not drawing air through said valve outlet, the movement of said valve piston assembly away from the position at which said valve piston assembly prevents air from flowing from said valve inlet chamber and through said valve outlet to the compression cylinder inlet causing said sliding seal to move away from said valve outlet to allow air to flow to said compression cylinder inlet.

53. The reciprocating air compressor unit of claim 41 further comprising:

a cylinder inlet chamber for receiving air before the air from said compression cylinder inlet enters said compression cylinder, an inlet hole being positioned between said cylinder inlet chamber and said compression cylinder to channel air from said compression cylinder inlet to said compression cylinder, said inlet hole having an inlet valve to prevent the movement of air from said compression cylinder back through said inlet hole when the piston compresses air with a compression stroke;

a compression cylinder outlet for receiving air that has been compressed by said compression cylinder and an outlet hole for channeling air from said compression cylinder into said outlet chamber, said outlet hole having an outlet valve to prevent the movement of air from said outlet chamber back through said outlet hole when said piston draws air through said inlet hole with an intake stroke;

a vent valve extending between said cylinder inlet chamber and said compressor outlet chamber, said vent valve having a closed position and an open position, said vent valve being biased to said closed position, said vent valve allowing air to pass between said cylinder inlet chamber and said compressor outlet chamber when said vent valve is in said open position;

and

said valve stem extends into said cylinder inlet chamber, said valve stem being constructed and positioned to engage and move said vent valve to the open position when said valve piston assembly is in a position within said inlet control mechanism that prevents air from flowing from said valve inlet chamber through said valve outlet, said valve stem being positioned to disengage said vent valve and allow said vent valve to move to said closed position when said valve piston assembly is in a position within said inlet control mechanism that allows air to flow from said valve inlet chamber through said valve outlet.

54. The reciprocating air compressor unit of claim 41 further comprising:

a cylinder inlet chamber in said compression cylinder inlet for receiving air before the air from said compression cylinder inlet enters said compression cylinder;

an inlet hole being positioned between said cylinder inlet chamber and said compression cylinder to channel air from said compression cylinder inlet to said compression cylinder, said inlet hole having an inlet valve to prevent the movement of air from said compression cylinder back through said inlet hole when the piston compresses air with a compression stroke;

a compression cylinder outlet for receiving air that has been compressed in said compression cylinder, said compression cylinder outlet having an outlet hole for channeling air from said compression cylinder outlet;

an air reservoir to receive and store compressed air that has been channeled through said outlet hole of said compression cylinder outlet;

a pilot valve responsive to the pressure of air that is stored within said air reservoir; and

an inlet unloader responsive to said pilot valve and configured to keep said inlet valve in an open position when the pressure of air stored within said air reservoir is greater than a predetermined magnitude, thereby preventing said piston from compressing air in said compression cylinder.

55. The reciprocating air compressor unit of claim 41 further comprising an adjustment mechanism, said adjustment mechanism having a plurality of adjustment positions, each said adjustment position allowing said valve piston assembly to move to one of a plurality of open positions within said inlet control mechanism, each of said plurality of open positions allows a predetermined amount of air to flow from said valve inlet chamber through said valve outlet during each piston reciprocation of said air compressor unit.

56. The reciprocating air compressor unit of claim 41 wherein said compressor unit includes an air reservoir, said automatic inlet control mechanism further comprising:

an equalization passage extending from the atmosphere surrounding said automatic inlet control to said valve control chamber; and

an equalization valve having an open position and a closed position, said equalization valve being responsive to the air pressure contained within said air reservoir and allowing air to flow through said equalization passage between the atmosphere and said valve control

chamber when said equalization valve is in said open position, said equalization preventing air from flowing between the atmosphere surrounding said inlet control and said valve control chamber when said equalization valve is in said closed position, said equalization valve moving to said closed position when the air pressure within said air reservoir falls below a predetermined minimum magnitude, said equalization valve moving to said open position when the air pressure within said air reservoir rises above a predetermined maximum magnitude.

57. The reciprocating air compressor unit of claim 41 further comprising:

an air reservoir to receive and store air that has been compressed in said compression cylinder;

a discharge tube to channel air from said compression cylinder to said air reservoir;

an outlet valve to prevent air from flowing from said discharge tube back into said compression cylinder;

a check valve to prevent air from flowing from said air reservoir back into said discharge tube;

a bleed passage extending between said discharge tube and said valve inlet chamber;

a bleed valve having an open position and a closed position, said bleed valve being biased to said closed position, said bleed valve allowing air to flow between said discharge tube and said valve inlet chamber when said bleed valve is in said open position, said bleed valve preventing air from flowing between said discharge tube and said valve inlet chamber when said bleed valve is in said closed position; and

a bleed pin mounted on said valve piston assembly, said bleed pin being positioned to reciprocate with said valve piston assembly within said inlet control mechanism, said bleed pin being configured to engage and move said bleed valve to said open position when said valve piston assembly is in a position within said inlet control mechanism that prevents air from flowing from said valve inlet chamber through said valve outlet, said bleed pin being positioned to disengage said bleed valve and allow said bleed valve to move to said closed position when said valve piston assembly is in a position within said inlet control mechanism that allows air to flow from said valve inlet chamber through said valve outlet.

58. A reciprocating air compressor unit which produces compressed air at a predetermined rate of production through the use of a piston that reciprocates within a compression cylinder, said air compressor unit comprising:

an automatic inlet control mechanism for connection to said compression cylinder inlet, said automatic inlet control having a mechanism body having a valve cavity, said valve cavity having a valve control chamber and a valve inlet chamber, a valve piston assembly positioned between said valve control chamber and said valve inlet chamber and constructed to prevent air flow between said valve control chamber and said valve inlet chamber;

a valve inlet positioned to allow air to flow from the atmosphere surrounding said compressor unit and into said valve inlet chamber;

a valve outlet having a valve outlet hole positioned to allow air to flow from said valve inlet chamber to said compression cylinder inlet, said valve outlet hole having a size sufficient to enable said compressor unit to produce compressed air at its predetermined rate of production;

said valve piston assembly including a valve piston and a valve stem, said valve piston assembly being positioned to reciprocate within said valve cavity, a biasing member having a force which moves said valve piston assembly to a position within said inlet control mechanism which prevents air from flowing from said valve inlet chamber through said valve outlet when said compressor unit is not drawing air through said valve outlet;

a vent passageway allowing air to flow between said valve control chamber and said compression cylinder inlet;

said vent passageway comprising the primary source of air to said compression cylinder inlet for a period of time after said compressor unit begins to draw air through said compression cylinder inlet following the movement of said valve piston assembly to a position which prevents air from flowing from said valve inlet chamber through said valve outlet to the compression cylinder inlet;

said vent passageway including a vent orifice which restricts the flow of air from said valve control chamber to said compression cylinder inlet; and

said vent orifice having an orifice size which allows air to be drawn, by the compressor unit, from said valve control chamber to said compression cylinder at a preselected rate which causes said compressor unit to produce compressed air at less than its predetermined rate of production, said valve control chamber having a volume which enables air to be drawn through said orifice from said valve control chamber by said compressor unit over a preselected time period until air within said valve control chamber is at a reduced pressure level which enables atmospheric pressure on said valve piston assembly from within said valve inlet chamber to overcome the force of said biasing member sufficiently to move said valve piston assembly away from said position at which said valve piston assembly prevents air from flowing from said valve inlet chamber and through said valve outlet to said compression cylinder inlet enable said compressor unit to produce compressed air at its predetermined rate of production.

59. The reciprocating air compressor unit of claim 58 wherein said valve piston assembly includes a diaphragm positioned between said valve control chamber and said valve inlet chamber, said diaphragm being constructed to prevent air flow between said valve control chamber and said valve inlet chamber, said diaphragm being positioned to move toward said valve control chamber when air pressure within said valve inlet chamber is greater than air pressure within said valve control chamber, said diaphragm being positioned to move toward said valve inlet chamber when air pressure within said valve control chamber is greater than the air pressure within said valve inlet chamber.

60. The reciprocating air compressor unit of claim 58 wherein said vent passageway is included within said valve piston assembly, said vent orifice being located at a position in said valve piston assembly to enable said vent orifice to restrict the flow of air from said valve control chamber to said compression cylinder inlet as said valve piston assembly reciprocates within said inlet control mechanism.

61. The reciprocating air compressor unit of claim 58 wherein said valve piston assembly includes a valve stem, said vent passageway is included within said valve piston assembly and extends through said valve stem, said vent orifice being located at a position in said piston assembly to enable said vent orifice to restrict the flow of air from said valve control

chamber to said compression cylinder inlet as said piston assembly reciprocates within said inlet control mechanism.

62. The reciprocating air compressor unit of claim 58 wherein said valve outlet includes a valve outlet hole having a tapered portion, said tapered portion having at least a first inner diameter and a second inner diameter, said first inner diameter of said tapered portion being larger than said second inner diameter and being located at a position that is closer to said valve inlet chamber than said second inner diameter, said second inner diameter being sufficiently small to form an air restriction against said valve piston assembly when said valve piston assembly is at a position within said inlet control mechanism which prevents air from flowing from said valve inlet chamber through said valve outlet, said first inner diameter of said tapered portion being sufficiently large to allow air to pass between said tapered portion of said valve outlet and said valve piston assembly when said valve piston assembly is at a position within said inlet control mechanism which allows air to flow from said valve inlet chamber through said valve outlet.

63. The reciprocating air compressor unit of claim 58 wherein said valve piston assembly includes a valve stem and a sliding seal mounted to reciprocate along at least a portion of said valve stem to contact said valve outlet to cause said valve piston assembly to prevent air from flowing from said valve inlet chamber through said valve outlet when the compressor unit is not drawing air through said valve outlet, the movement of said valve piston assembly away from the position at which said valve piston assembly prevents air from flowing from said valve inlet chamber and through said valve outlet to said compression cylinder inlet causing said sliding seal to move away from said valve outlet to allow air to flow to said compression cylinder inlet.

64. The reciprocating air compressor unit of claim 58 wherein said valve inlet includes a filter to remove impurities from air that passes through said valve inlet and enters said valve inlet chamber.

65. The reciprocating air compressor unit of claim 58 wherein said valve piston assembly includes a valve stem and a sliding seal mounted to reciprocate along at least a portion of said valve stem to contact said valve outlet to cause said valve piston assembly to prevent air from flowing from said valve inlet chamber through said valve outlet when the compressor unit is not drawing air through said valve outlet, the movement of said valve piston assembly away from the position at which said valve piston assembly prevents air from flowing from said valve inlet chamber and through said valve outlet to said compression cylinder inlet causing said sliding seal to move away from said valve outlet to allow air to flow to said compression cylinder inlet, said valve inlet including a filter to remove impurities from air that passes through said valve inlet and enters said valve inlet chamber.

66. The reciprocating air compressor unit of claim 58 wherein said compression cylinder inlet includes a cylinder inlet chamber for receiving air from said compression cylinder inlet before the air enters said compression cylinder, said vent passageway being positioned to allow for air to flow, outside said valve piston assembly, directly between said valve control chamber and said cylinder inlet chamber.

67. The reciprocating air compressor unit of claim 58 wherein:

said compression cylinder inlet includes a cylinder inlet chamber for receiving air from said compression cylinder inlet before the air enters said compression cylinder, said vent passageway being positioned to allow for air to flow, outside said valve piston assembly, directly between said valve control chamber and said cylinder inlet chamber; and

said valve piston assembly includes a valve stem and a sliding seal mounted to reciprocate along at least a portion of said valve stem to contact said valve outlet to cause said valve piston assembly to prevent air from flowing from said valve inlet chamber through said valve outlet when said compressor unit is not drawing air through said valve outlet, the movement of said valve piston assembly away from the position at which said valve piston assembly prevents air from flowing from said valve inlet chamber and through said valve outlet to said compression cylinder inlet causing said sliding seal to move away from said valve outlet to allow air to flow to said compression cylinder inlet.

68. The reciprocating air compressor unit of claim 58 wherein said compression cylinder inlet includes a cylinder inlet chamber for receiving air before the air from said compression cylinder inlet enters said compression cylinder, said automatic inlet control mechanism being located at least partially within said cylinder inlet chamber.

69. The reciprocating air compressor unit of claim 58 wherein:

said compression cylinder inlet includes a cylinder inlet chamber for receiving air before the air from said compression cylinder inlet enters said compression cylinder, said automatic inlet control mechanism being located at least partially within said cylinder inlet chamber; and

said valve piston assembly includes a valve stem and a sliding seal mounted to reciprocate along at least a portion of said valve stem to contact said valve outlet to cause said valve piston assembly to prevent air from flowing from said valve inlet chamber through said valve outlet when the compressor unit is not drawing air through said valve outlet, the movement of said valve piston assembly away from the position at which said valve piston assembly prevents air from flowing from said valve inlet chamber and through said valve outlet to the compression cylinder inlet causing said sliding seal to move away from said valve outlet to allow air to flow to said compression cylinder inlet.

70. The reciprocating air compressor unit of claim 58 further comprising:

a cylinder inlet chamber for receiving air before the air from said compression cylinder inlet enters said compression cylinder, an inlet hole being positioned between said cylinder inlet chamber and said compression cylinder to channel air from said compression cylinder inlet to said compression cylinder, said inlet hole having an inlet valve to prevent the movement of air from said compression cylinder back through said inlet hole when the piston compresses air with a compression stroke;

a compression cylinder outlet for receiving air that has been compressed by said compression cylinder and an outlet hole for channeling air from said compression cylinder into said outlet chamber, said outlet hole having an outlet valve to prevent the movement of air from said outlet chamber back through said outlet hole when said piston draws air through said inlet hole with an intake stroke;

a vent valve extending between said cylinder inlet chamber and said compressor outlet chamber, said vent valve having a closed position and an open position, said vent valve being biased to said closed position, said vent valve allowing air to pass between said cylinder inlet chamber and said compressor outlet chamber when said vent valve is in said open position; and

said valve stem extends into said cylinder inlet chamber, said valve stem being constructed and positioned to engage and move said vent valve to the open position when said valve piston assembly is in a position within said inlet control mechanism that prevents air from flowing from said valve inlet chamber through said valve outlet, said valve stem being positioned to disengage said vent valve and allow said vent valve to move to said closed position when said valve piston assembly is in a position within said inlet control mechanism that allows air to flow from said valve inlet chamber through said valve outlet.

71. The reciprocating air compressor unit of claim 58 further comprising:

a cylinder inlet chamber in said compression cylinder inlet for receiving air before the air from said compression cylinder inlet enters said compression cylinder;

an inlet hole being positioned between said cylinder inlet chamber and said compression cylinder to channel air from said compression cylinder inlet to said compression cylinder, said inlet hole having an inlet valve to prevent the movement of air from said compression cylinder back through said inlet hole when the piston compresses air with a compression stroke;

a compression cylinder outlet for receiving air that has been compressed in said compression cylinder, said compression cylinder outlet having an outlet hole for channeling air from said compression cylinder outlet;

an air reservoir to receive and store compressed air that has been channeled through said outlet hole of said compression cylinder outlet;

a pilot valve responsive to the pressure of air that is stored within said air reservoir; and

an inlet unloader responsive to said pilot valve and configured to keep said inlet valve in an open position when the pressure of air stored within said air reservoir is greater than a

predetermined magnitude, thereby preventing said piston from compressing air in said compression cylinder.

72. The reciprocating air compressor unit of claim 58 further comprising an adjustment mechanism, said adjustment mechanism having a plurality of adjustment positions, each said adjustment position allowing said valve piston assembly to move to one of a plurality of open positions within said inlet control mechanism, each of said plurality of open positions allows a predetermined amount of air to flow from said valve inlet chamber through said valve outlet during each piston reciprocation of said air compressor unit.

73. The reciprocating air compressor unit of claim 58 wherein said compressor unit includes an air reservoir, said automatic inlet control mechanism further comprising:

an equalization passage extending from the atmosphere surrounding said automatic inlet control to said valve control chamber; and

an equalization valve having an open position and a closed position, said equalization valve being responsive to the air pressure contained within said air reservoir and allowing air to flow through said equalization passage between the atmosphere and said valve control chamber when said equalization valve is in said open position, said equalization preventing air from flowing between the atmosphere surrounding said inlet control and said valve control chamber when said equalization valve is in said closed position, said equalization valve moving to said closed position when the air pressure within said air reservoir falls below a predetermined minimum magnitude, said equalization valve moving to said open position when the air pressure within said air reservoir rises above a predetermined maximum magnitude.

74. The reciprocating air compressor unit of claim 58 further comprising:

an air reservoir to receive and store air that has been compressed in said compression cylinder;

a discharge tube to channel air from said compression cylinder to said air reservoir;

an outlet valve to prevent air from flowing from said discharge tube back into said compression cylinder;

a check valve to prevent air from flowing from said air reservoir back into said discharge tube;

a bleed passage extending between said discharge tube and said valve inlet chamber;

a bleed valve having an open position and a closed position, said bleed valve being biased to said closed position, said bleed valve allowing air to flow between said discharge tube and said valve inlet chamber when said bleed valve is in said open position, said bleed valve preventing air from flowing between said discharge tube and said valve inlet chamber when said bleed valve is in said closed position; and

a bleed pin mounted on said valve piston assembly, said bleed pin being positioned to reciprocate with said valve piston assembly within said inlet control mechanism, said bleed pin being configured to engage and move said bleed valve to said open position when said valve piston assembly is in a position within said inlet control mechanism that prevents air from flowing from said valve inlet chamber through said valve outlet, said bleed pin being positioned to disengage said bleed valve and allow said bleed valve to move to said closed position when said valve piston assembly is in a position within said inlet control mechanism that allows air to flow from said valve inlet chamber through said valve outlet.

75. A reciprocating air compressor unit which produces compressed air at a predetermined rate of production, said reciprocating air compressor unit comprising:

a mechanism body having a valve cavity, said valve cavity having a valve control chamber and a valve inlet chamber, a valve piston assembly positioned between said valve control chamber and said valve inlet chamber and constructed to prevent air flow between said valve control chamber and said valve inlet chamber, said valve piston assembly including a diaphragm positioned between said valve control chamber and said valve inlet chamber, said diaphragm being constructed to prevent air flow between said valve control chamber and said valve inlet chamber, said diaphragm being positioned to move toward said valve control chamber when air pressure within said valve inlet chamber is greater than air pressure within said valve control chamber, said diaphragm being positioned to move toward said valve inlet

chamber when air pressure within said valve control chamber is greater than the air pressure within said valve inlet chamber;

a valve inlet positioned to allow air to flow from the atmosphere surrounding said compressor unit and into said valve inlet chamber;

a valve outlet having a valve outlet hole positioned to allow air to flow from said valve inlet chamber to said compression cylinder inlet, said valve outlet hole having a size sufficient to enable said compressor unit to produce compressed air at its predetermined rate of production;

a valve piston and a valve stem included in said valve piston assembly, said valve piston assembly being positioned to reciprocate within said valve cavity, a biasing member having a force which moves said valve piston assembly to a position within said mechanism body which prevents air from flowing from said valve inlet chamber to said valve outlet when the compressor unit is not drawing air through said valve outlet;

a vent passageway included in said valve piston assembly, said vent passageway allowing air to flow between said valve control chamber and said compression cylinder inlet, said vent passageway comprising at least one source of air to the compression cylinder inlet for a period of time after the compressor unit begins to draw air through said compression cylinder inlet following the movement of said valve piston assembly to a position which prevents air from flowing from said valve inlet chamber through said valve outlet;

a valve outlet hole having a tapered portion included in said valve outlet, said tapered portion having a first inner diameter and a second inner diameter, said first inner diameter being larger than said second inner diameter, said first inner diameter of said tapered portion being located at a position that is closer to said valve inlet chamber than said second inner diameter of said tapered portion, said second inner diameter of said tapered portion being sufficiently small to form an air restriction against said valve piston assembly when said valve piston assembly is at a position within said mechanism body which prevents air from flowing from said valve inlet chamber through said valve outlet, said first inner diameter of said tapered portion being sufficiently large to allow air to pass between said tapered portion of said valve

outlet hole and said valve piston assembly when said valve piston assembly is at a position within said mechanism body which allows air to flow from said valve inlet chamber through said valve outlet;

said vent passageway including a vent orifice which restricts the flow of air from said valve control chamber to said compression cylinder inlet; and

said vent orifice having an orifice size which allows air to be drawn by said compressor unit from said valve control chamber to said compression cylinder at a preselected rate which causes the compressor unit to produce compressed air at less than its predetermined rate of production, said valve control chamber having a volume which enables air to be drawn through said orifice from said valve control chamber by said compressor unit over a preselected time period until air within said valve control chamber is at a reduced pressure level which enables atmospheric pressure on the valve piston assembly from within said valve inlet chamber to overcome the force of said biasing member sufficiently to move said valve piston assembly away from the position at which said valve piston assembly prevents air from flowing from said valve inlet chamber through said valve outlet to enable said compressor unit to produce compressed air at its predetermined rate of production.

76. The reciprocating air compressor unit of claim 75 wherein said valve piston assembly includes a sliding seal mounted to reciprocate along at least a portion of said valve stem to contact said valve outlet to cause said valve piston assembly to prevent air from flowing from said valve inlet chamber through said valve outlet when said compressor unit is not drawing air through said valve outlet, the movement of said valve piston assembly away from the position at which said valve piston assembly prevents air from flowing from said valve inlet chamber and through said valve outlet to said compression cylinder inlet causing said sliding seal to move away from said valve outlet to allow air to flow to said compression cylinder inlet.

77. The reciprocating air compressor unit of claim 75 wherein said valve inlet includes a filter to remove impurities from air that passes through said valve inlet and enters said valve inlet chamber.

78. The reciprocating air compressor unit of claim 75 wherein said valve piston assembly includes a sliding seal mounted to reciprocate along at least a portion of said valve stem to contact said valve outlet to cause said valve piston assembly to prevent air from flowing from said valve inlet chamber through said valve outlet when said air compressor unit is not drawing air through said valve outlet, the movement of said valve piston assembly away from the position at which said valve piston assembly prevents air from flowing from said valve inlet chamber and through said valve outlet to said compression cylinder inlet causing said sliding seal to move away from said valve outlet to allow air to flow to said compression cylinder inlet, said valve inlet including a filter to remove impurities from air that passes through said valve inlet and enters said valve inlet chamber.

79. A reciprocating air compressor unit which produces compressed air at a predetermined rate of production, said reciprocating air compressor unit comprising:

a mechanism body having a valve cavity, said valve cavity having a valve control chamber and a valve inlet chamber, a valve piston assembly positioned between said valve control chamber and said valve inlet chamber and constructed to prevent air flow between said valve control chamber and said valve inlet chamber, said valve piston assembly including a diaphragm positioned between said valve control chamber and said valve inlet chamber, said diaphragm being constructed to prevent air flow between said valve control chamber and said valve inlet chamber, said diaphragm being positioned to move toward said valve control chamber when air pressure within said valve inlet chamber is greater than air pressure within said valve control chamber, said diaphragm being positioned to move toward said valve inlet chamber when air pressure within said valve control chamber is greater than the air pressure within said valve inlet chamber;

a valve inlet positioned to allow air to flow from the atmosphere surrounding said compressor unit and into said valve inlet chamber;

a valve outlet having a valve outlet hole positioned to allow air to flow from said valve inlet chamber to said compression cylinder inlet, said valve outlet hole having a size sufficient

to enable said compressor unit to produce compressed air at its predetermined rate of production;

a valve piston and a valve stem included in said valve piston assembly, said valve piston assembly being positioned to reciprocate within said valve cavity, a biasing member having a force which moves said valve piston assembly to a position within said mechanism body which prevents air from flowing from said valve inlet chamber to said valve outlet when the compressor unit is not drawing air through said valve outlet;

a vent passageway included in said valve piston assembly, said vent passageway allowing air to flow between said valve control chamber and said compression cylinder inlet;

said vent passageway comprising the primary source of air to the compression cylinder inlet for a period of time after the compressor unit begins to draw air through said compression cylinder inlet following the movement of said valve piston assembly to a position which prevents air from flowing from said valve inlet chamber through said valve outlet;

a valve outlet hole having a tapered portion included in said valve outlet, said tapered portion having a first inner diameter and a second inner diameter, said first inner diameter being larger than said second inner diameter, said first inner diameter of said tapered portion being located at a position that is closer to said valve inlet chamber than said second inner diameter of said tapered portion, said second inner diameter of said tapered portion being sufficiently small to form an air restriction against said valve piston assembly when said valve piston assembly is at a position within said mechanism body which prevents air from flowing from said valve inlet chamber through said valve outlet, said first inner diameter of said tapered portion being sufficiently large to allow air to pass between said tapered portion of said valve outlet hole and said valve piston assembly when said valve piston assembly is at a position within said mechanism body which allows air to flow from said valve inlet chamber through said valve outlet;

said vent passageway including a vent orifice which restricts the flow of air from said valve control chamber to said compression cylinder inlet; and

said vent orifice having an orifice size which allows air to be drawn by said compressor unit from said valve control chamber to said compression cylinder at a preselected rate which causes the compressor unit to produce compressed air at less than its predetermined rate of production, said valve control chamber having a volume which enables air to be drawn through said orifice from said valve control chamber by said compressor unit over a preselected time period until air within said valve control chamber is at a reduced pressure level which enables atmospheric pressure on the valve piston assembly from within said valve inlet chamber to overcome the force of said biasing member sufficiently to move said valve piston assembly away from the position at which said valve piston assembly prevents air from flowing from said valve inlet chamber through said valve outlet to enable said compressor unit to produce compressed air at its predetermined rate of production.

80. The reciprocating air compressor unit of claim 79 wherein said valve piston assembly includes a sliding seal mounted to reciprocate along at least a portion of said valve stem to contact said valve outlet to cause said valve piston assembly to prevent air from flowing from said valve inlet chamber through said valve outlet when said compressor unit is not drawing air through said valve outlet, the movement of said valve piston assembly away from the position at which said valve piston assembly prevents air from flowing from said valve inlet chamber and through said valve outlet to said compression cylinder inlet causing said sliding seal to move away from said valve outlet to allow air to flow to said compression cylinder inlet.

81. The reciprocating air compressor unit of claim 79 wherein said valve inlet includes a filter to remove impurities from air that passes through said valve inlet and enters said valve inlet chamber.

82. The reciprocating air compressor unit of claim 79 wherein said valve piston assembly includes a sliding seal mounted to reciprocate along at least a portion of said valve stem to contact said valve outlet to cause said valve piston assembly to prevent air from flowing from said valve inlet chamber through said valve outlet when said air compressor unit is not drawing air through said valve outlet, the movement of said valve piston assembly away from the position at which said valve piston assembly prevents air from flowing from said valve inlet

chamber and through said valve outlet to said compression cylinder inlet causing said sliding seal to move away from said valve outlet to allow air to flow to said compression cylinder inlet, said valve inlet including a filter to remove impurities from air that passes through said valve inlet and enters said valve inlet chamber.

1/35

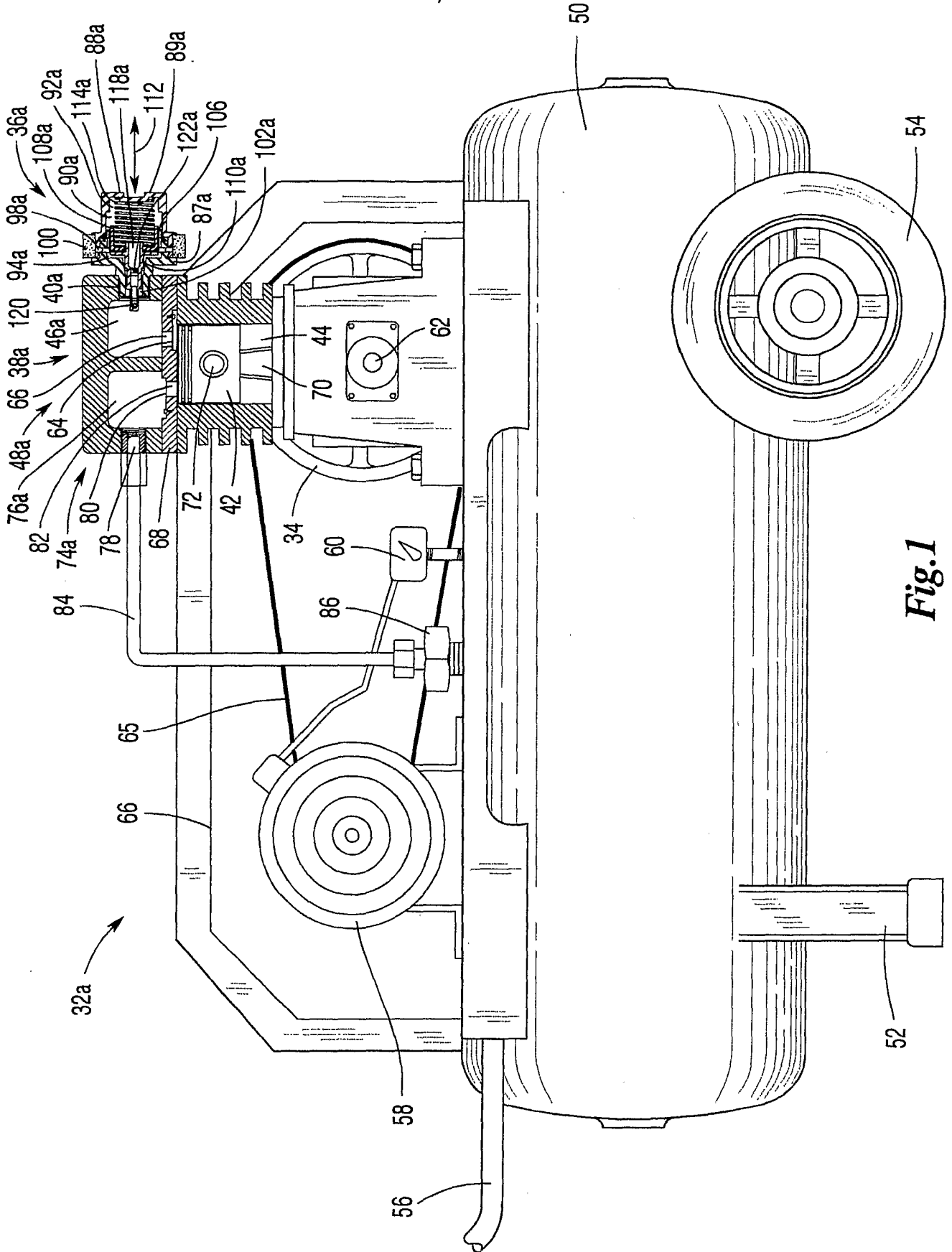


Fig.1



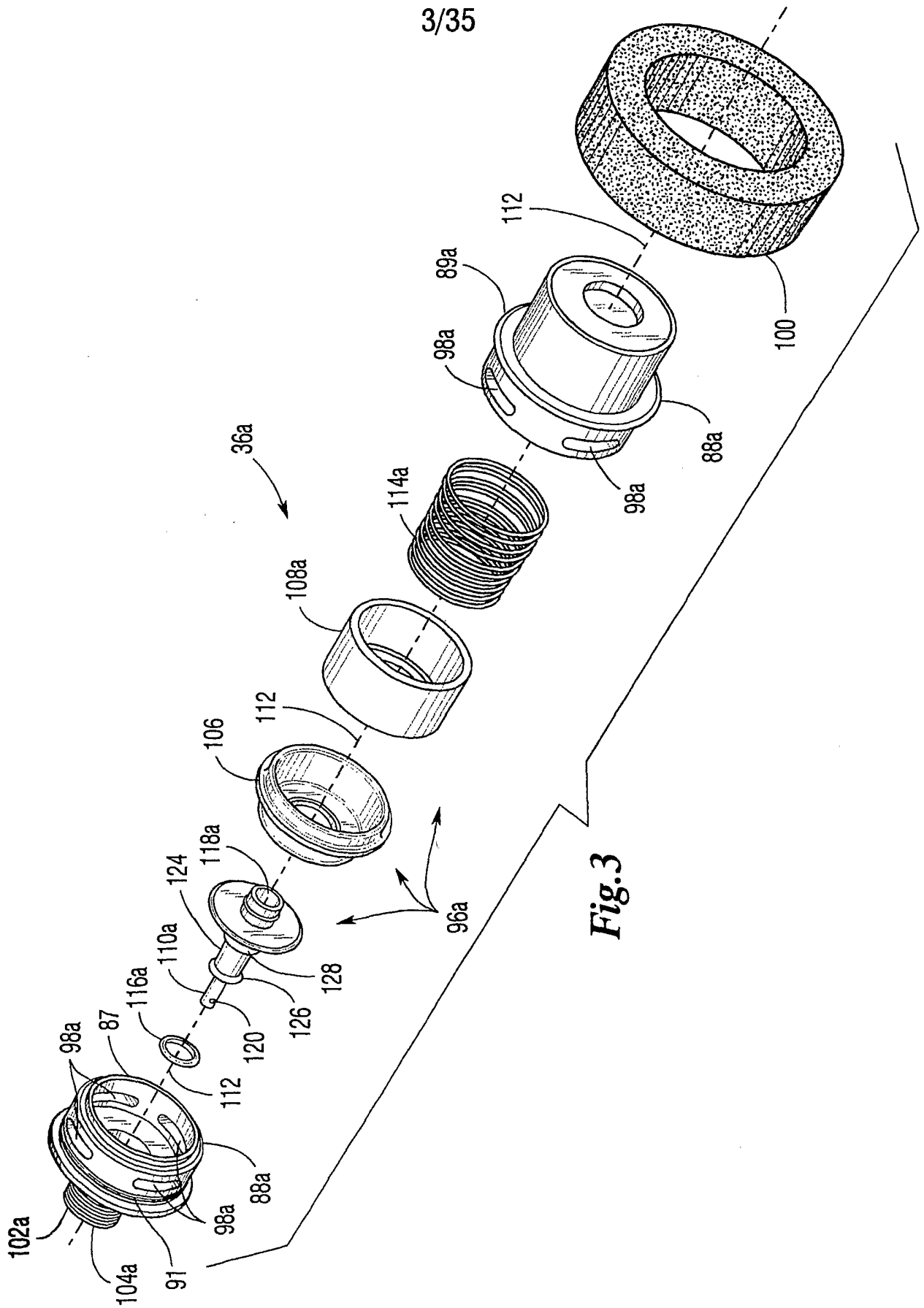


Fig.3

4/35

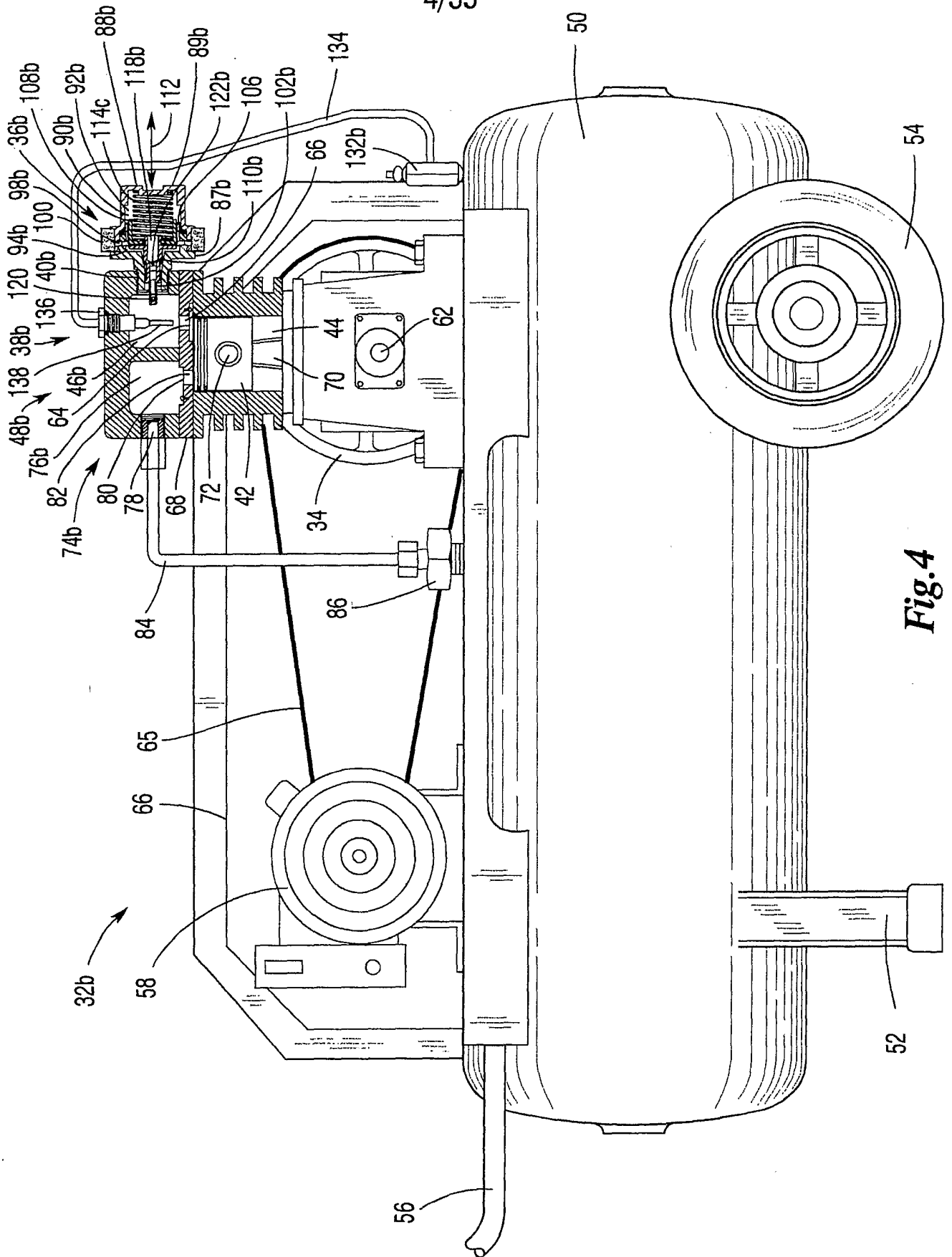


Fig. 4

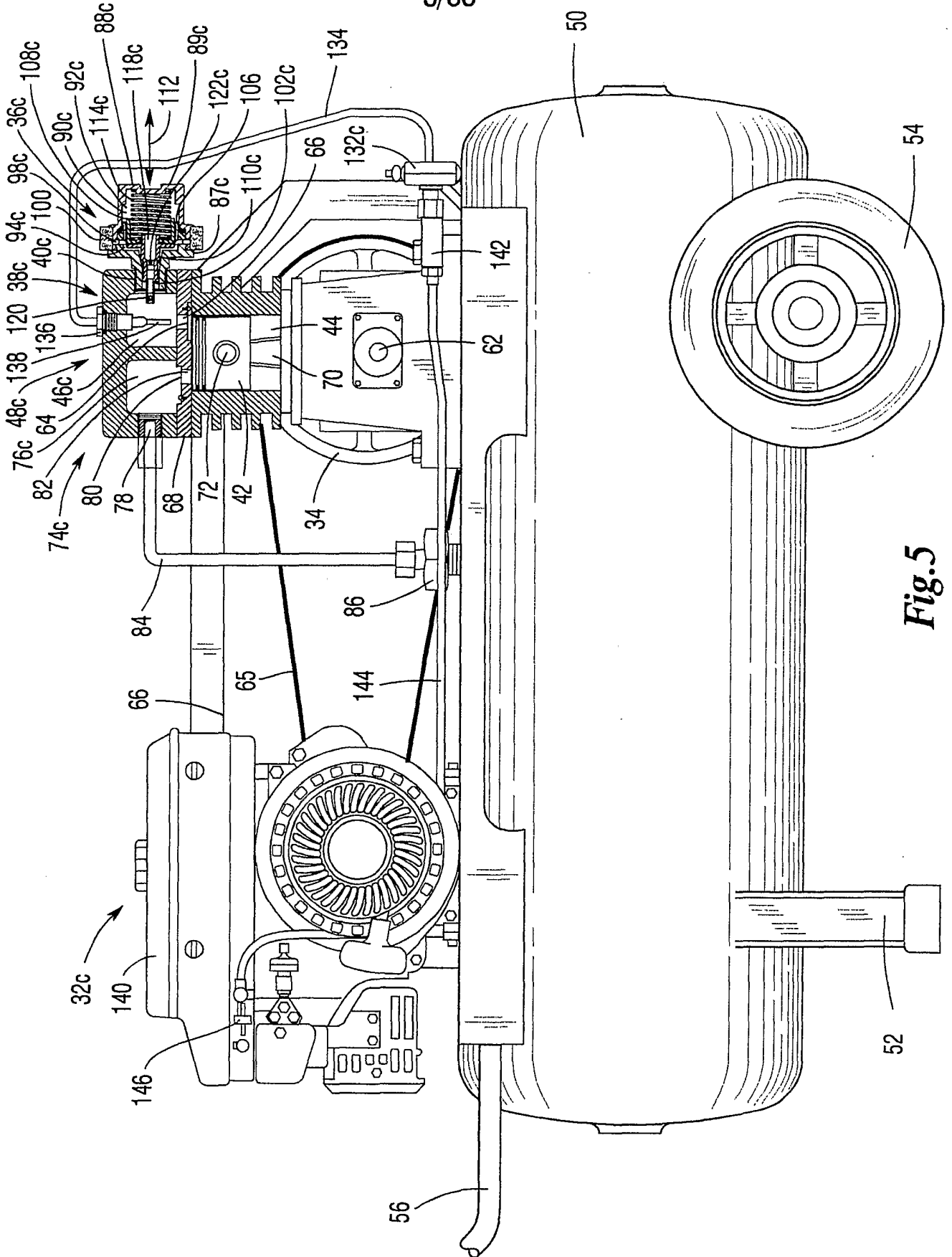
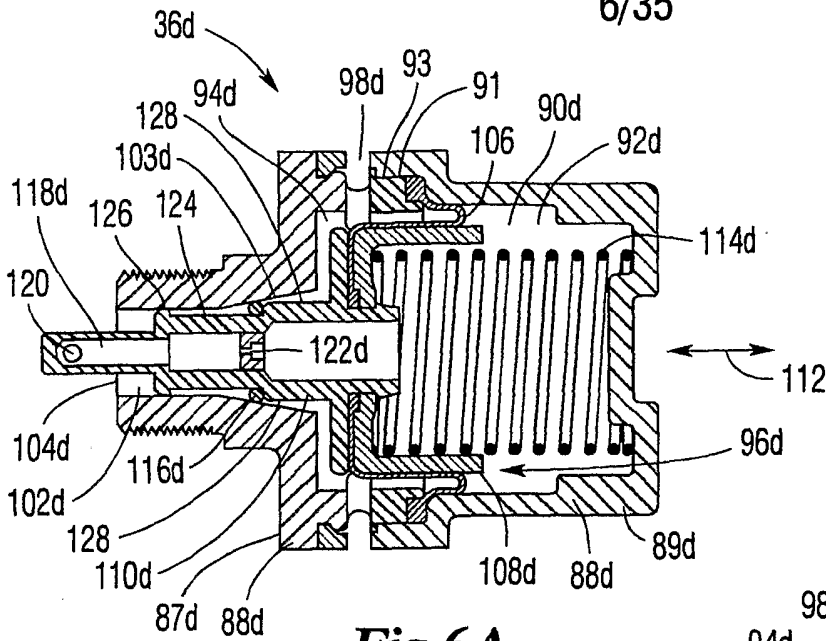
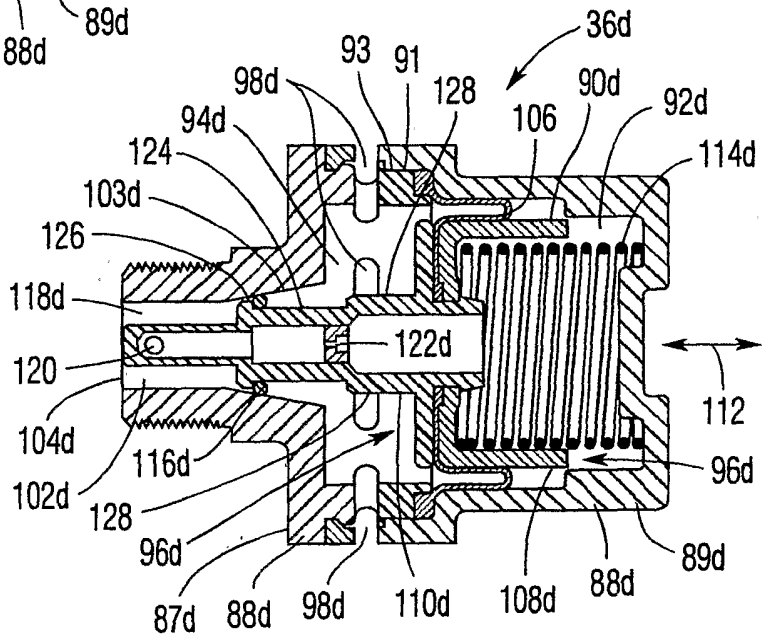


Fig. 5

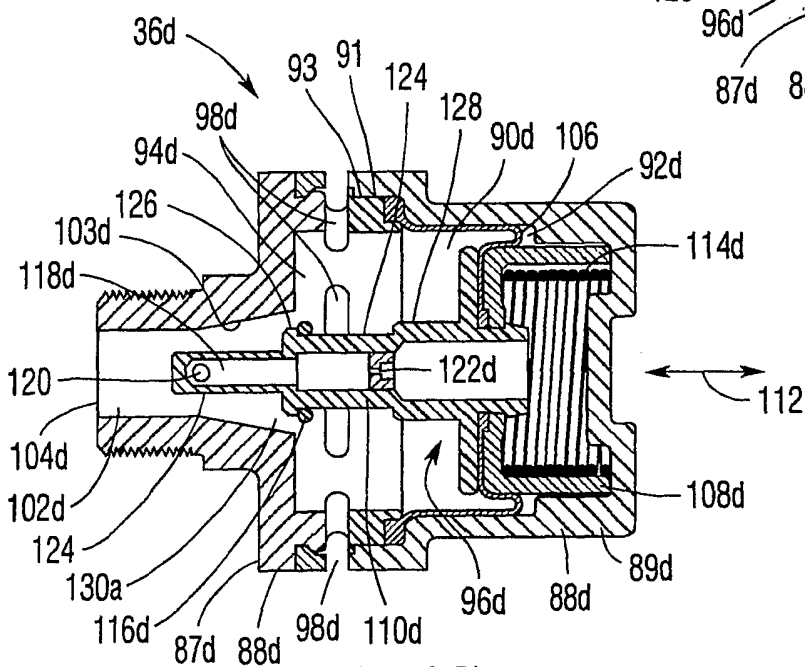
6/35



**Fig. 6A**



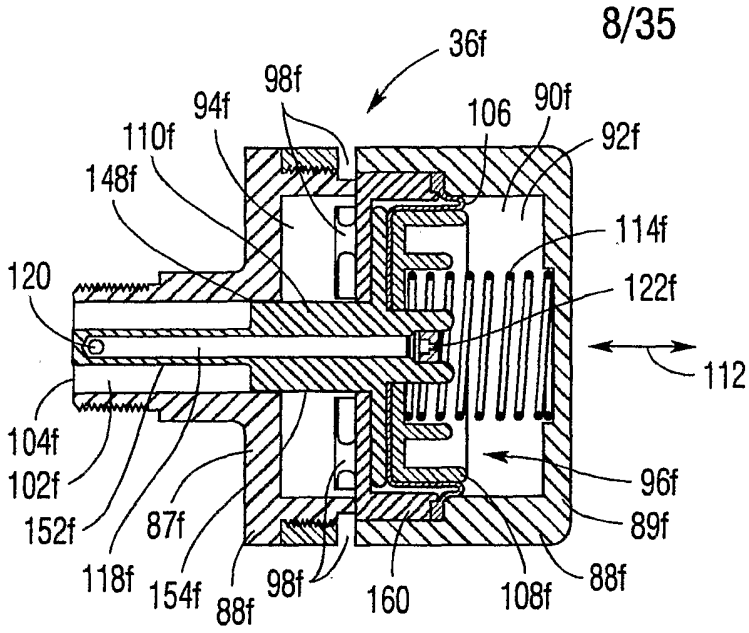
**Fig. 6B**



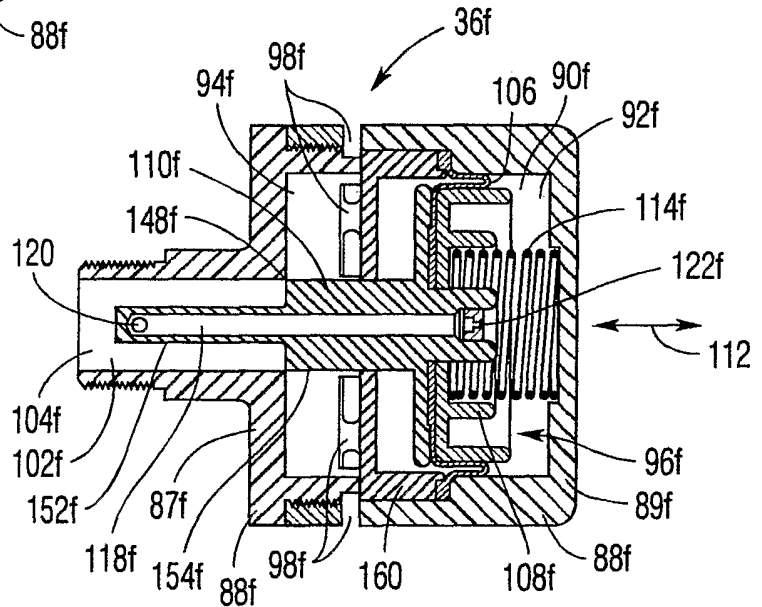
**Fig. 6C**



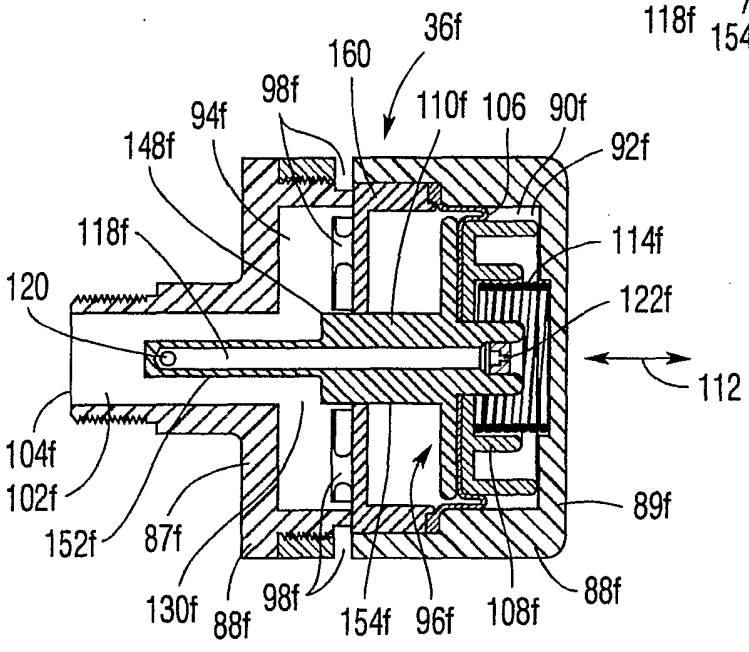
8/35



**Fig. 8A**



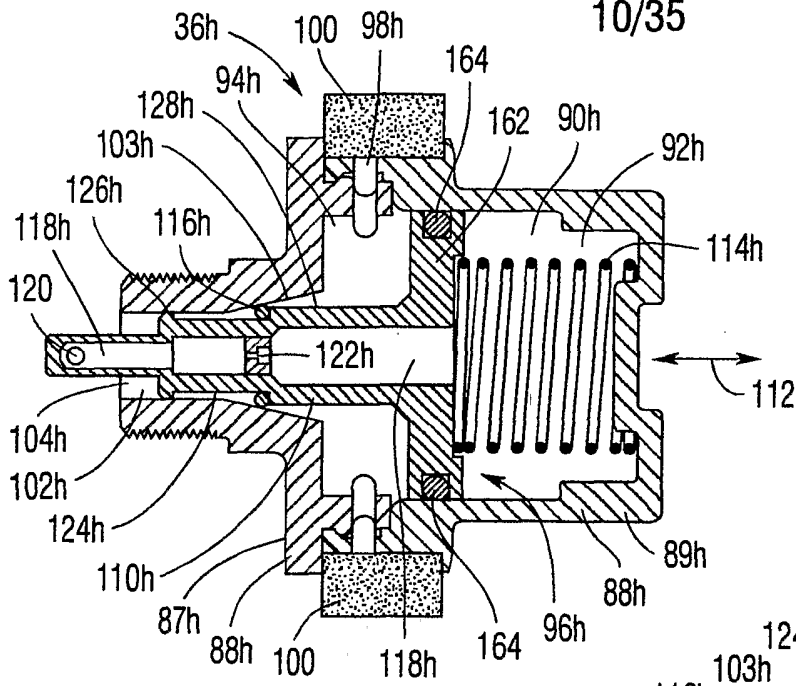
**Fig. 8B**



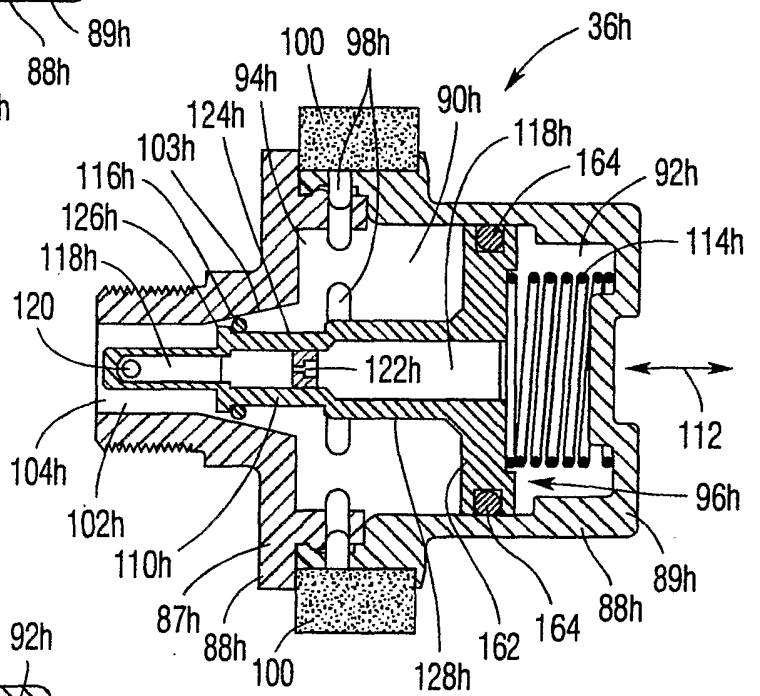
**Fig. 8C**



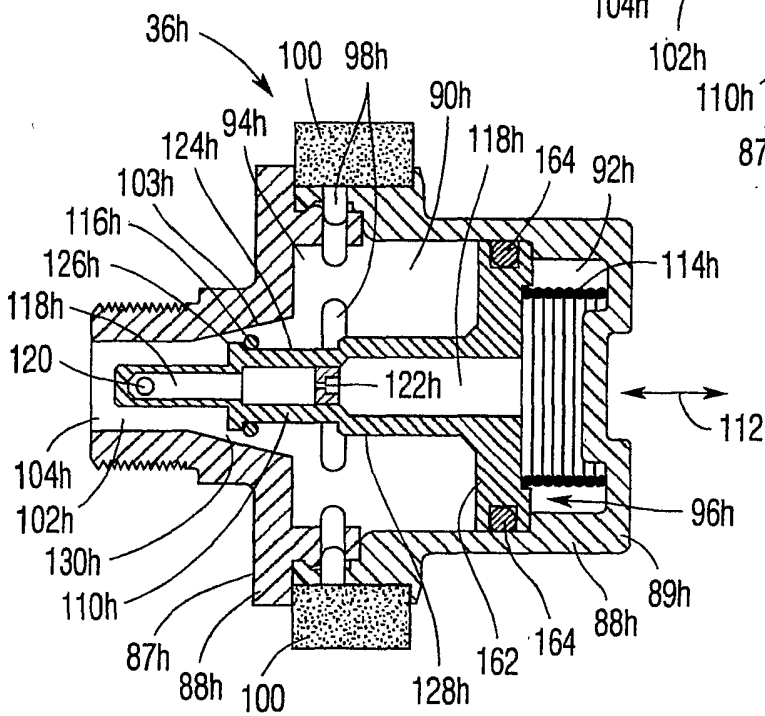
10/35



**Fig.10A**



**Fig.10B**



**Fig.10C**

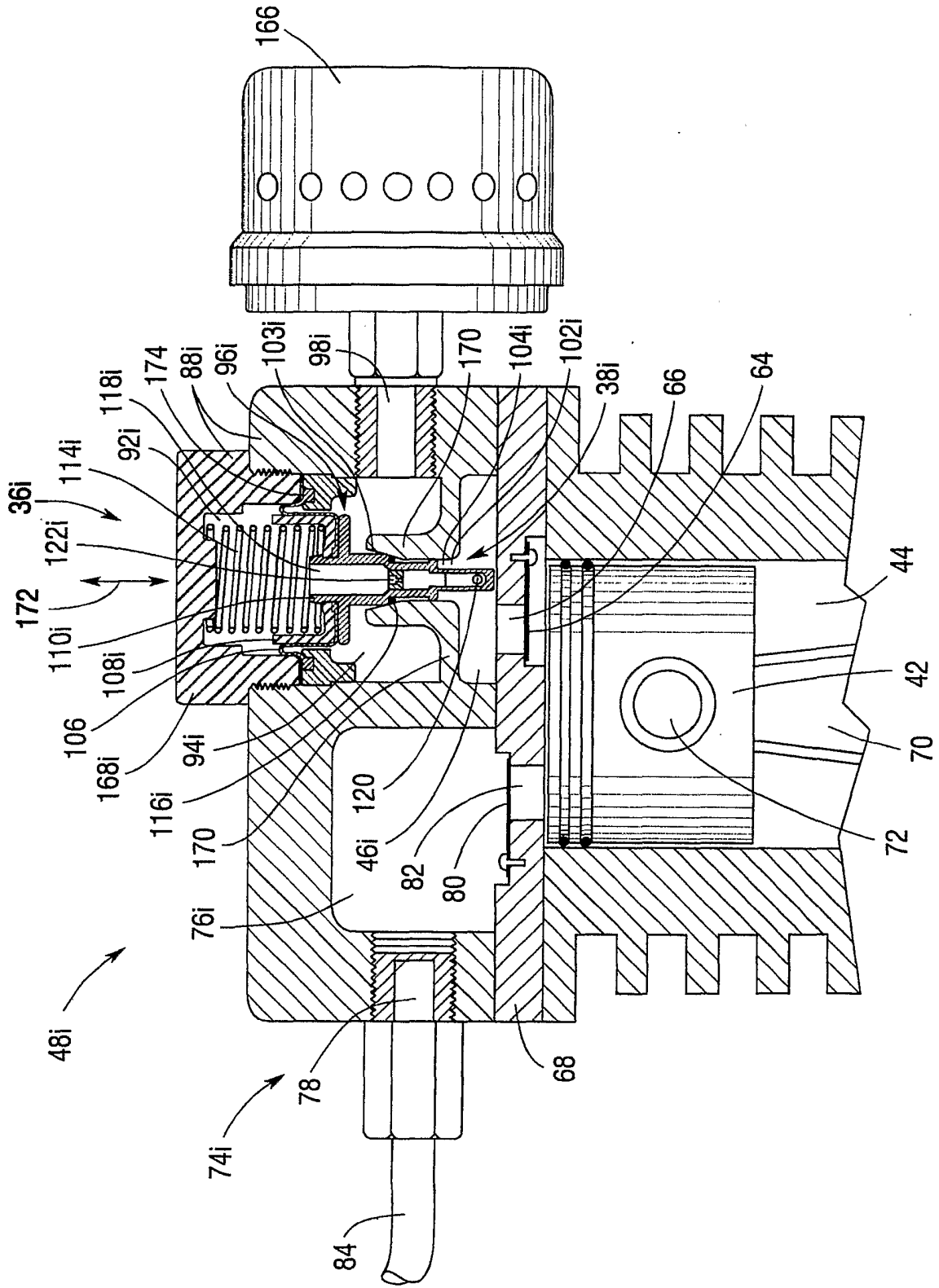


Fig. 11A

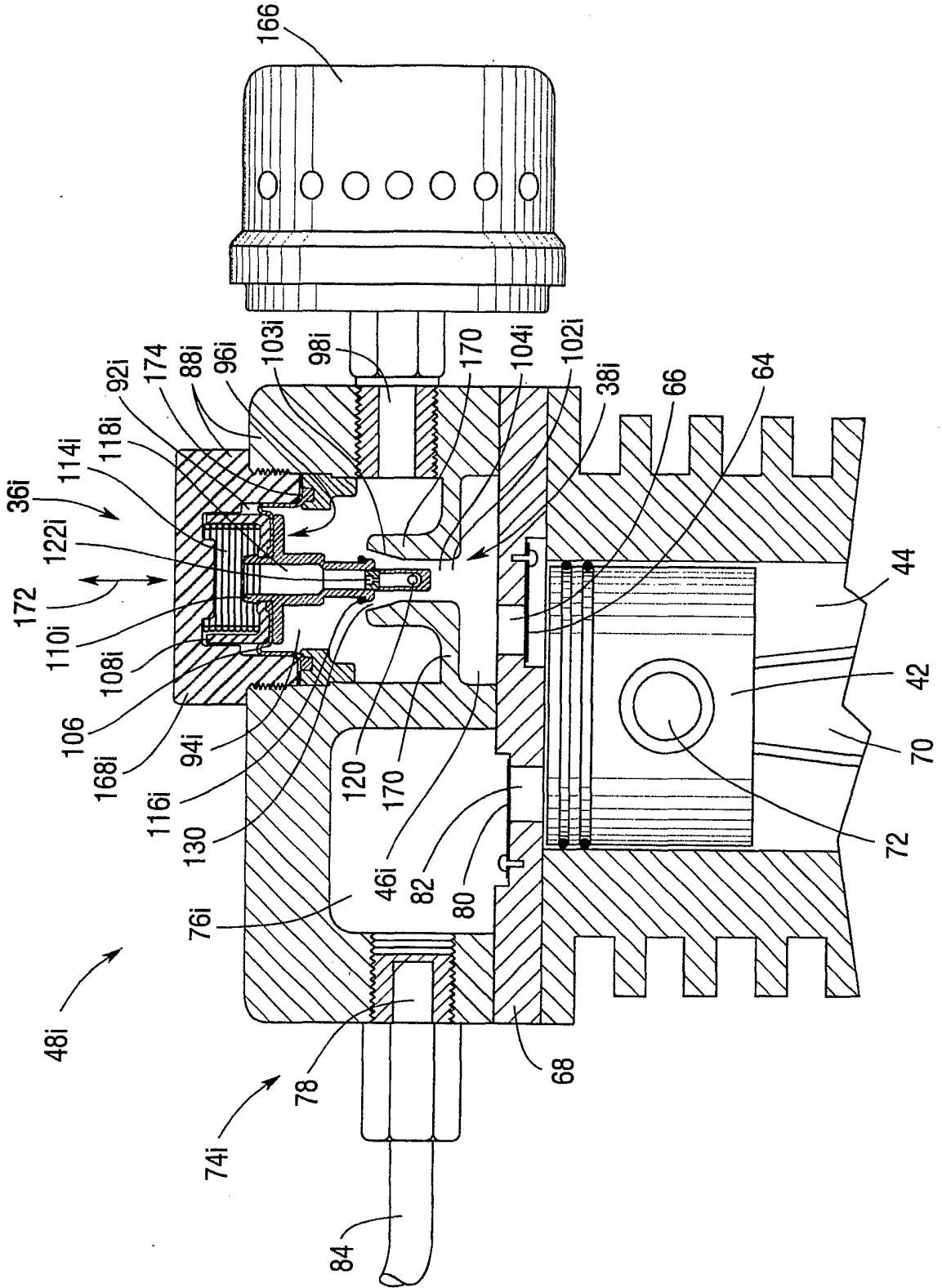


Fig. 11B

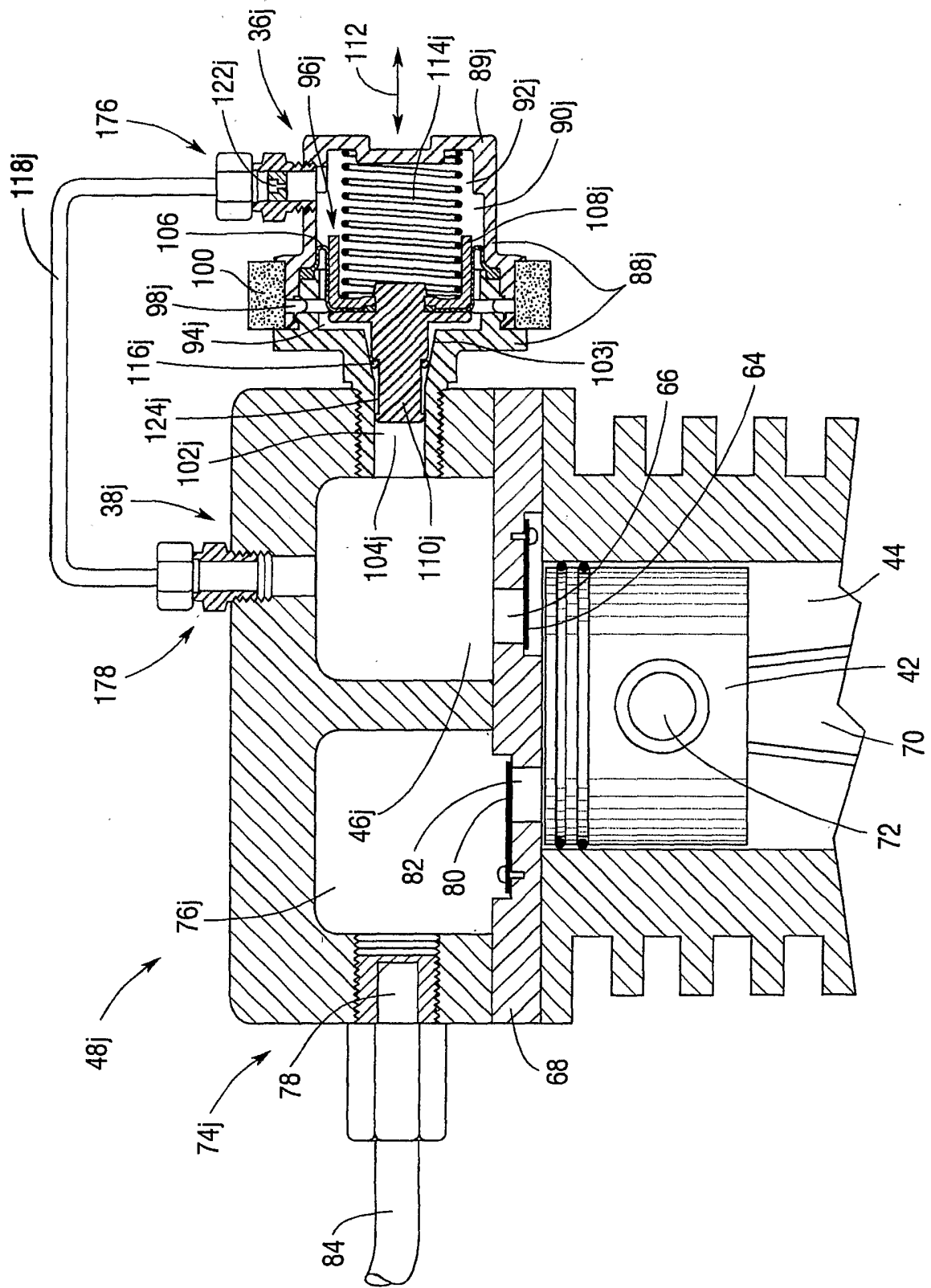


Fig. 12A

14/35

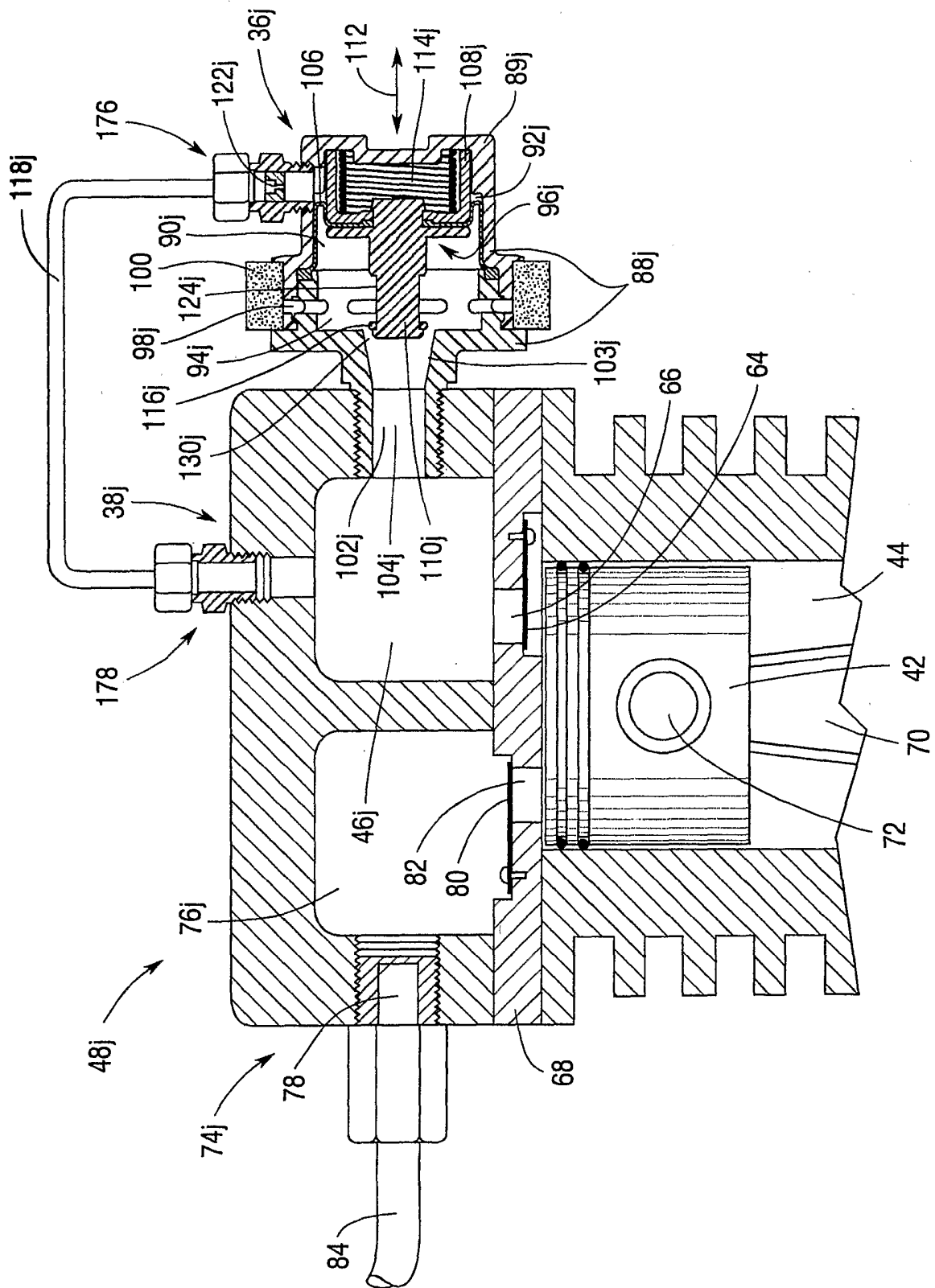


Fig. 12B

15/35

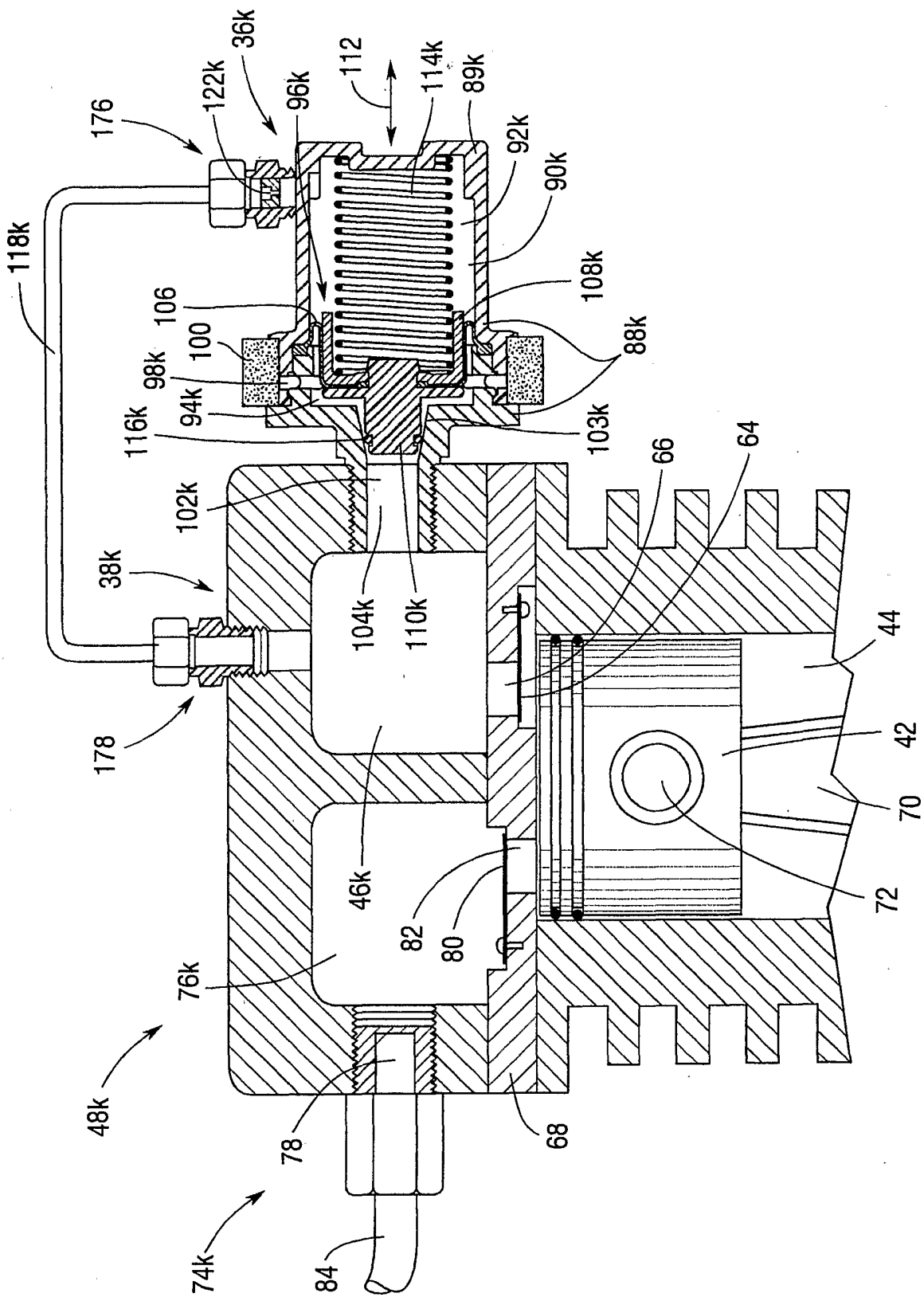


Fig. 13A

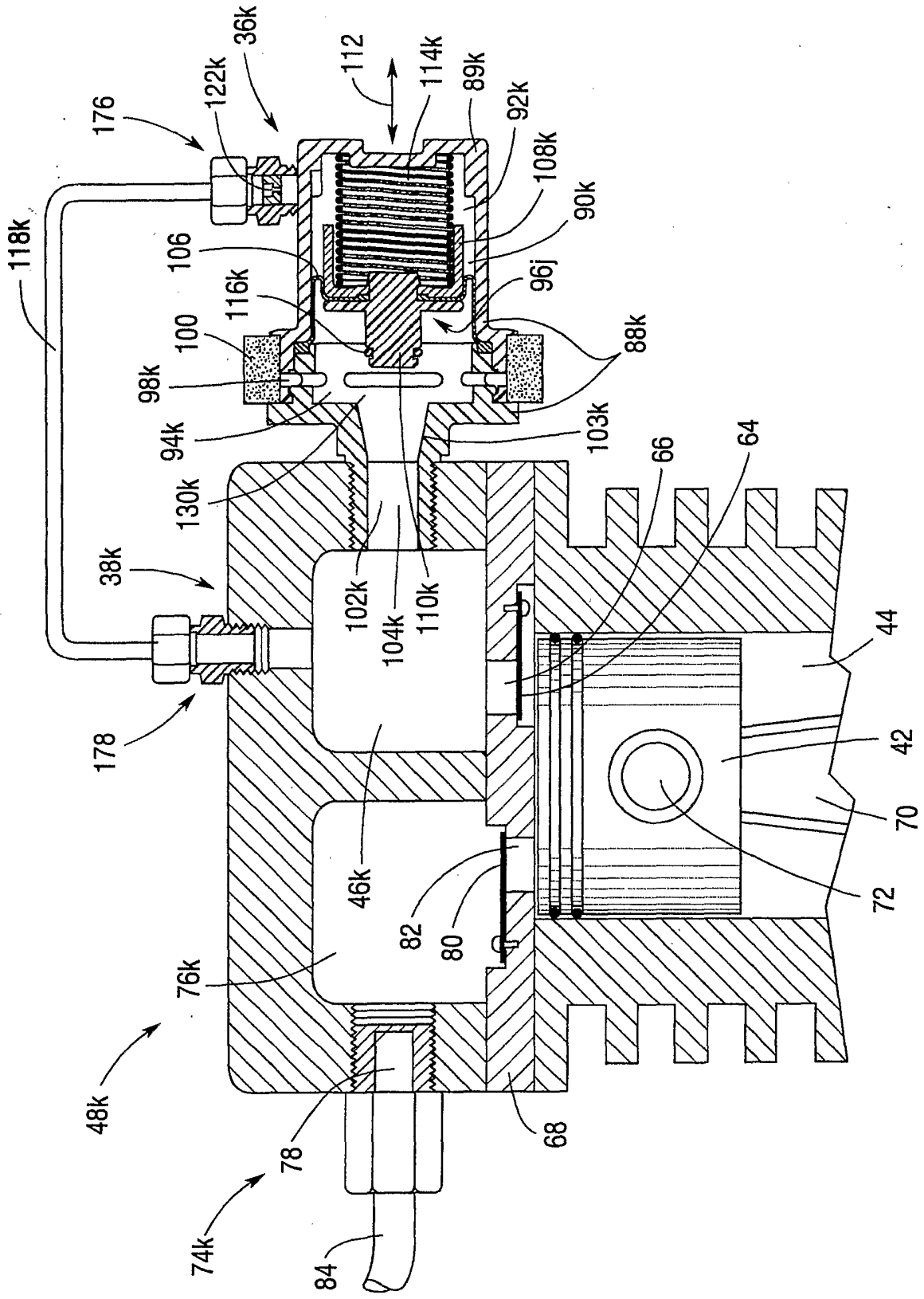
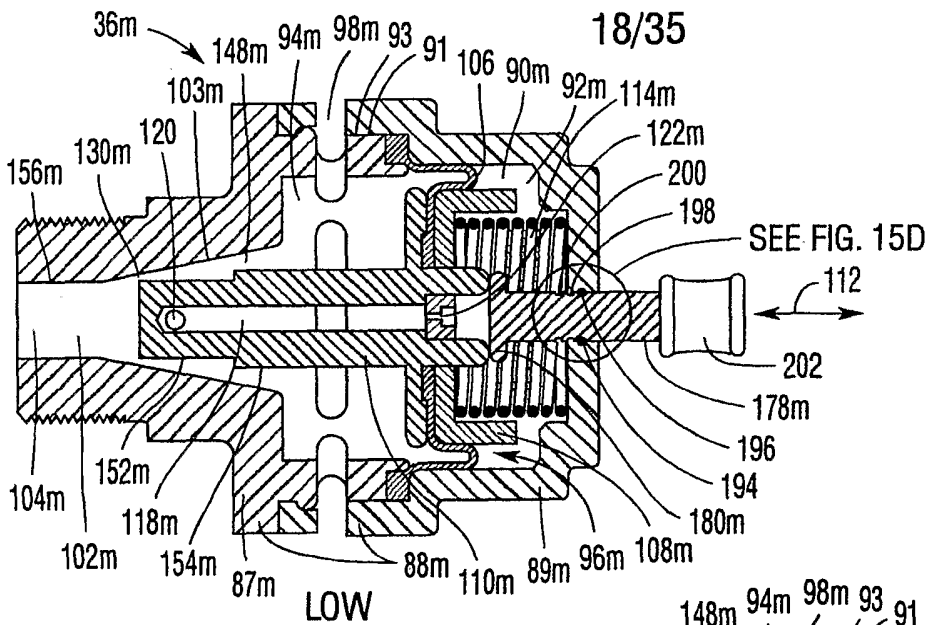
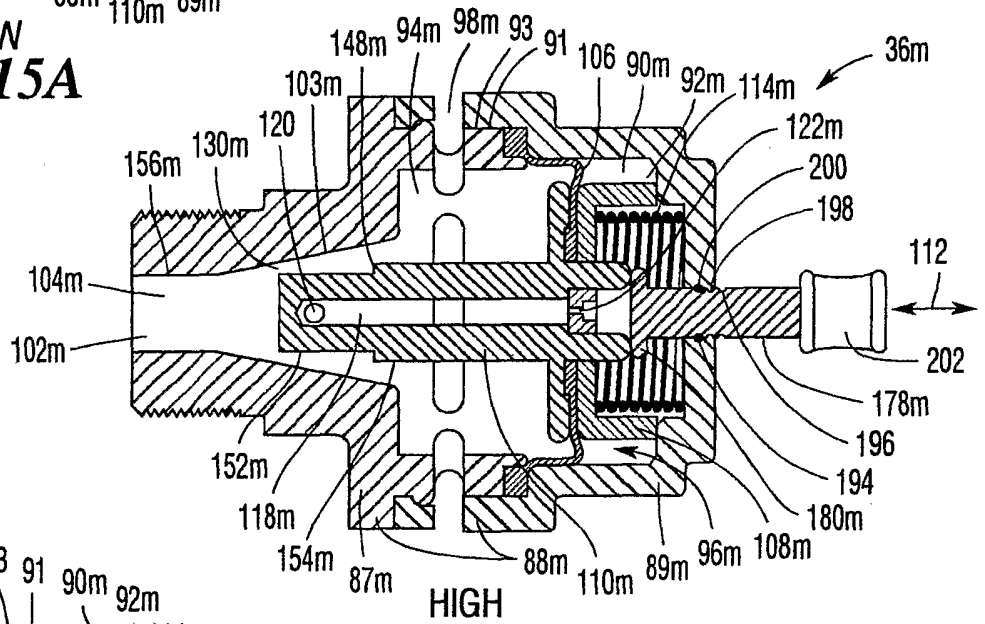


Fig. 13B

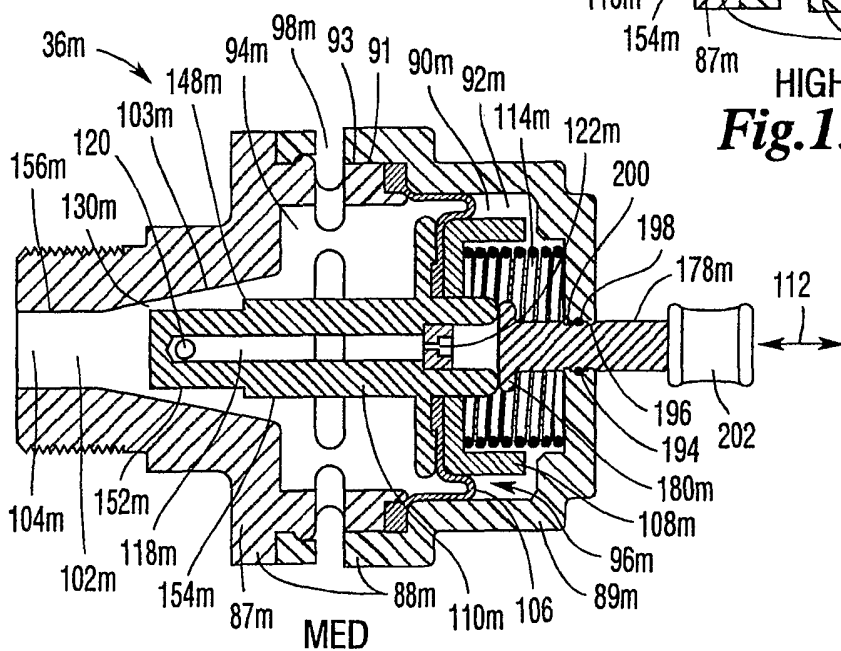




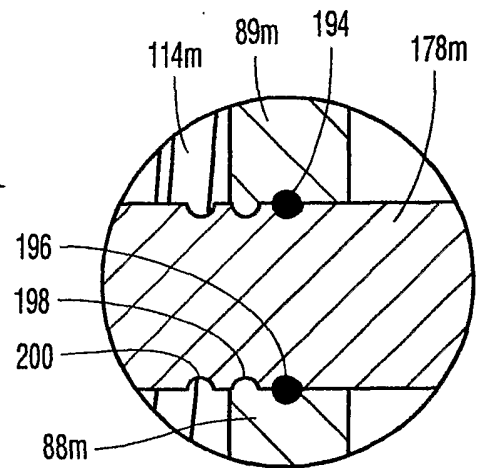
LOW  
**Fig. 15A**



HIGH  
**Fig. 15C**

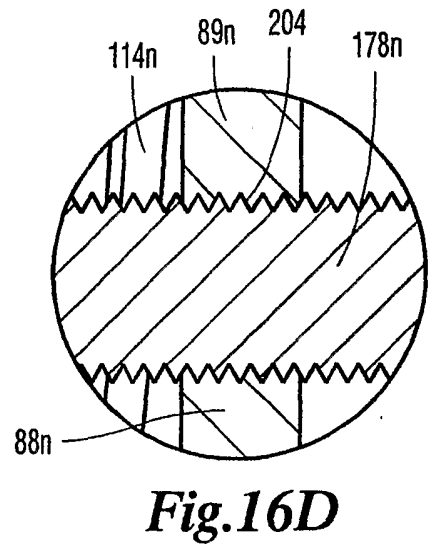
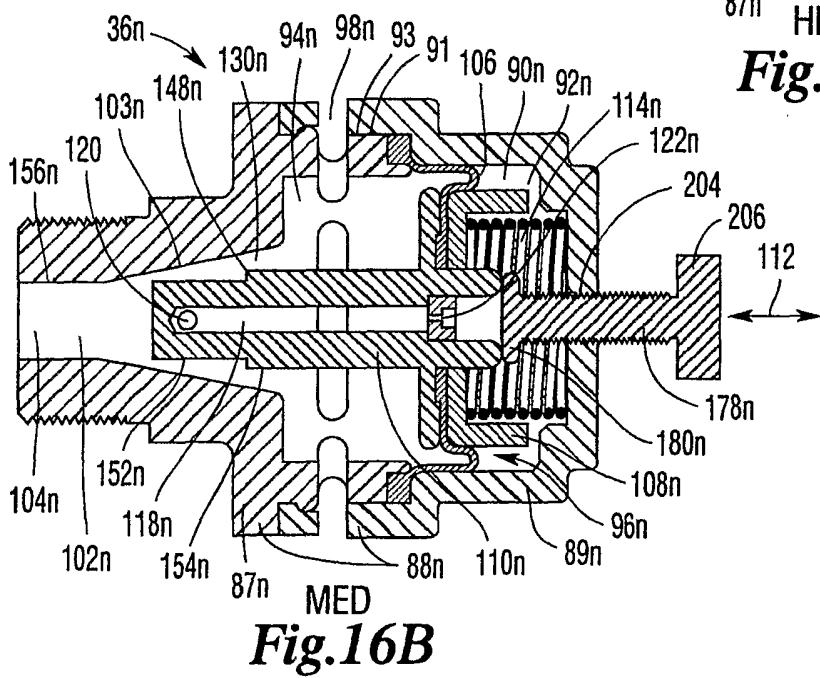
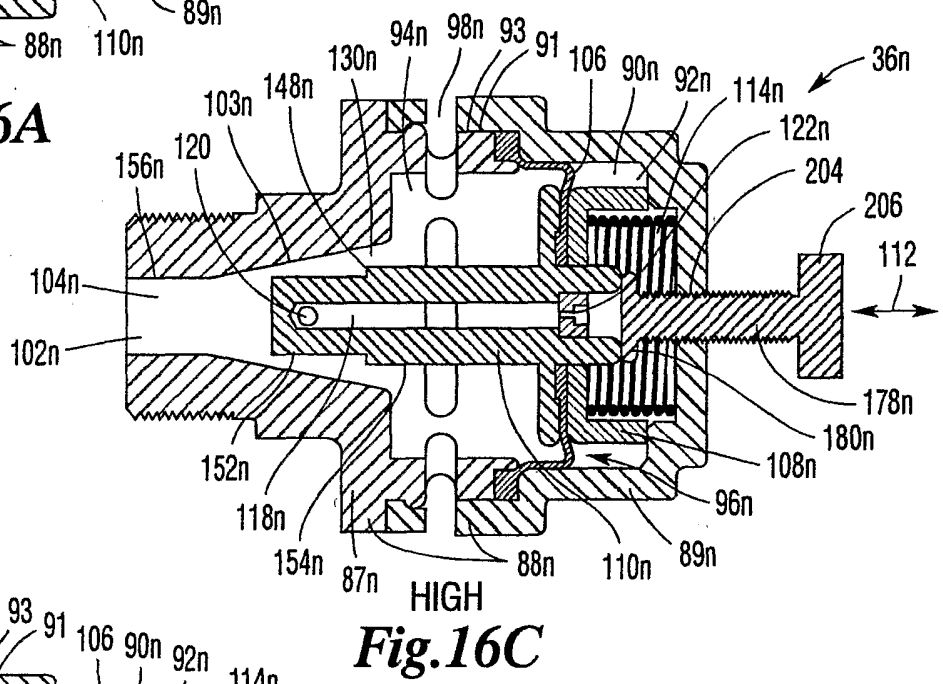
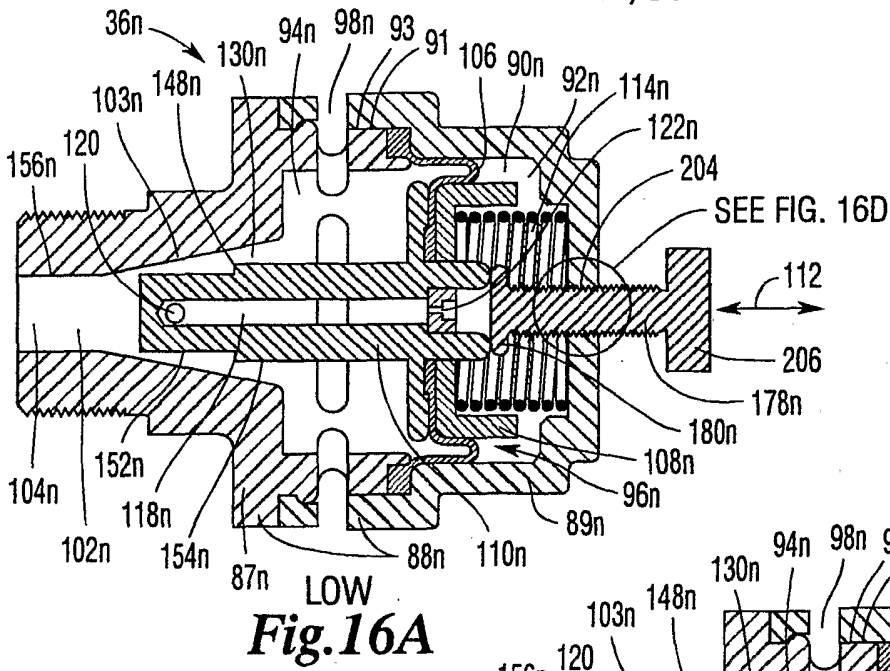


MED  
**Fig. 15B**

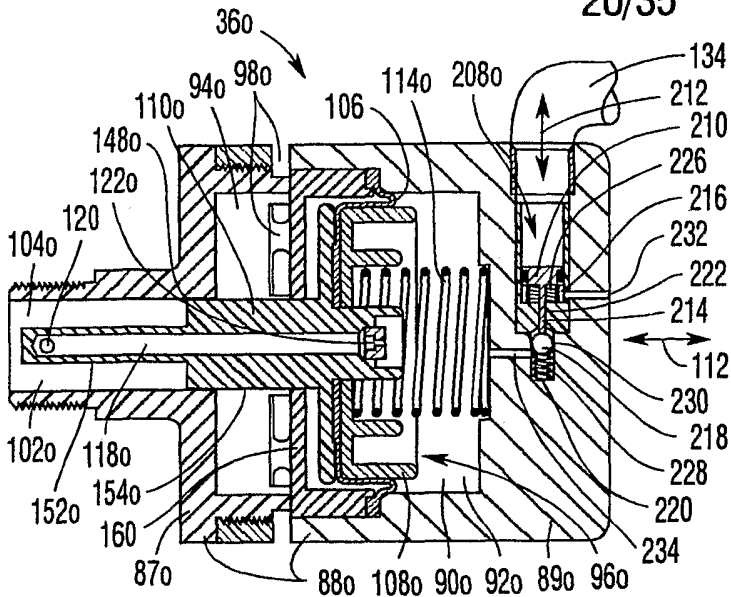


**Fig. 15D**

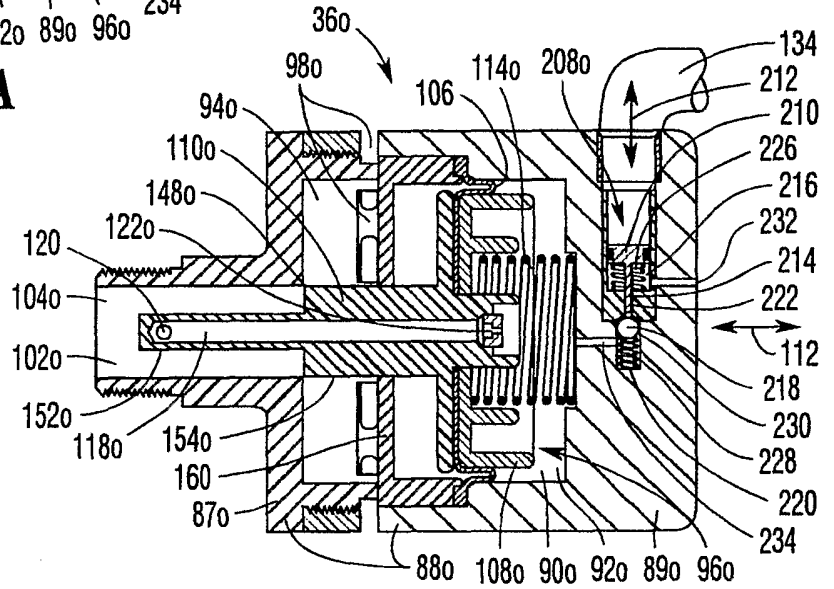
19/35



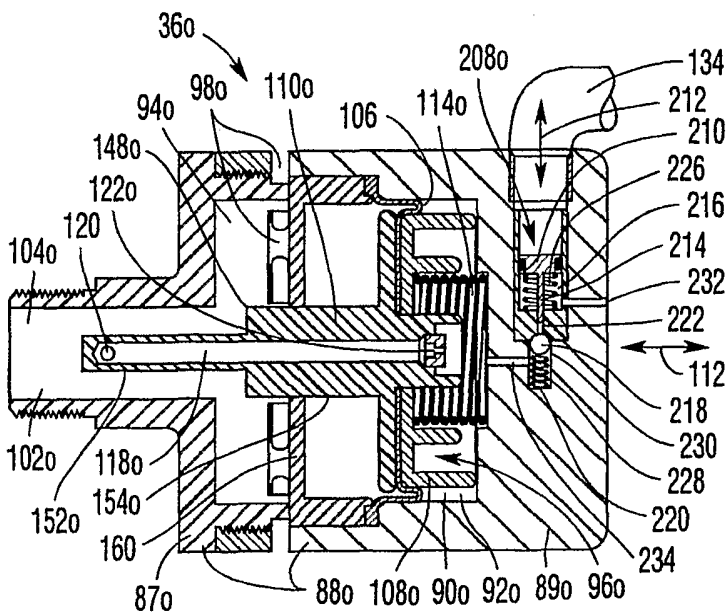
20/35



**Fig.17A**

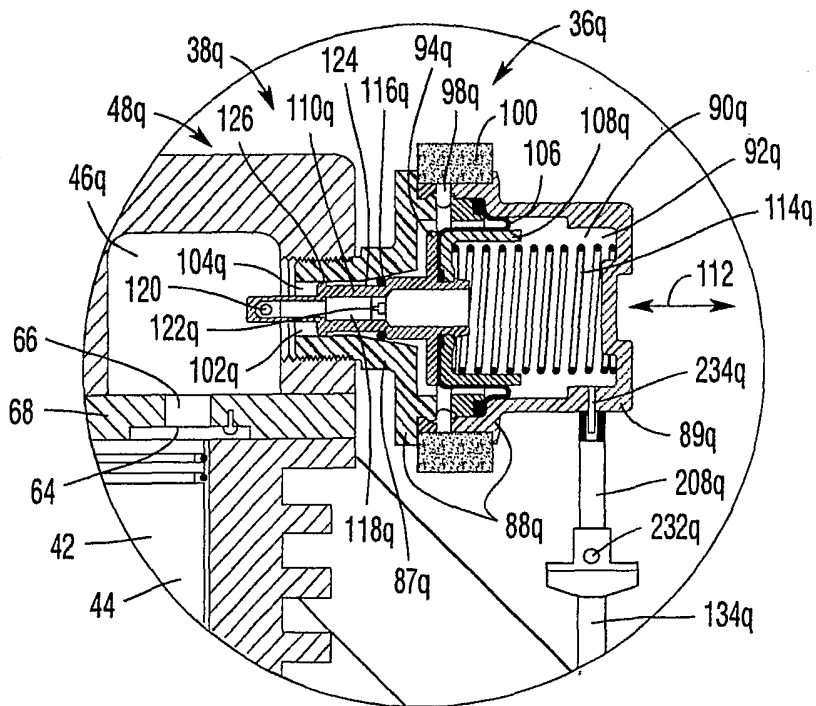
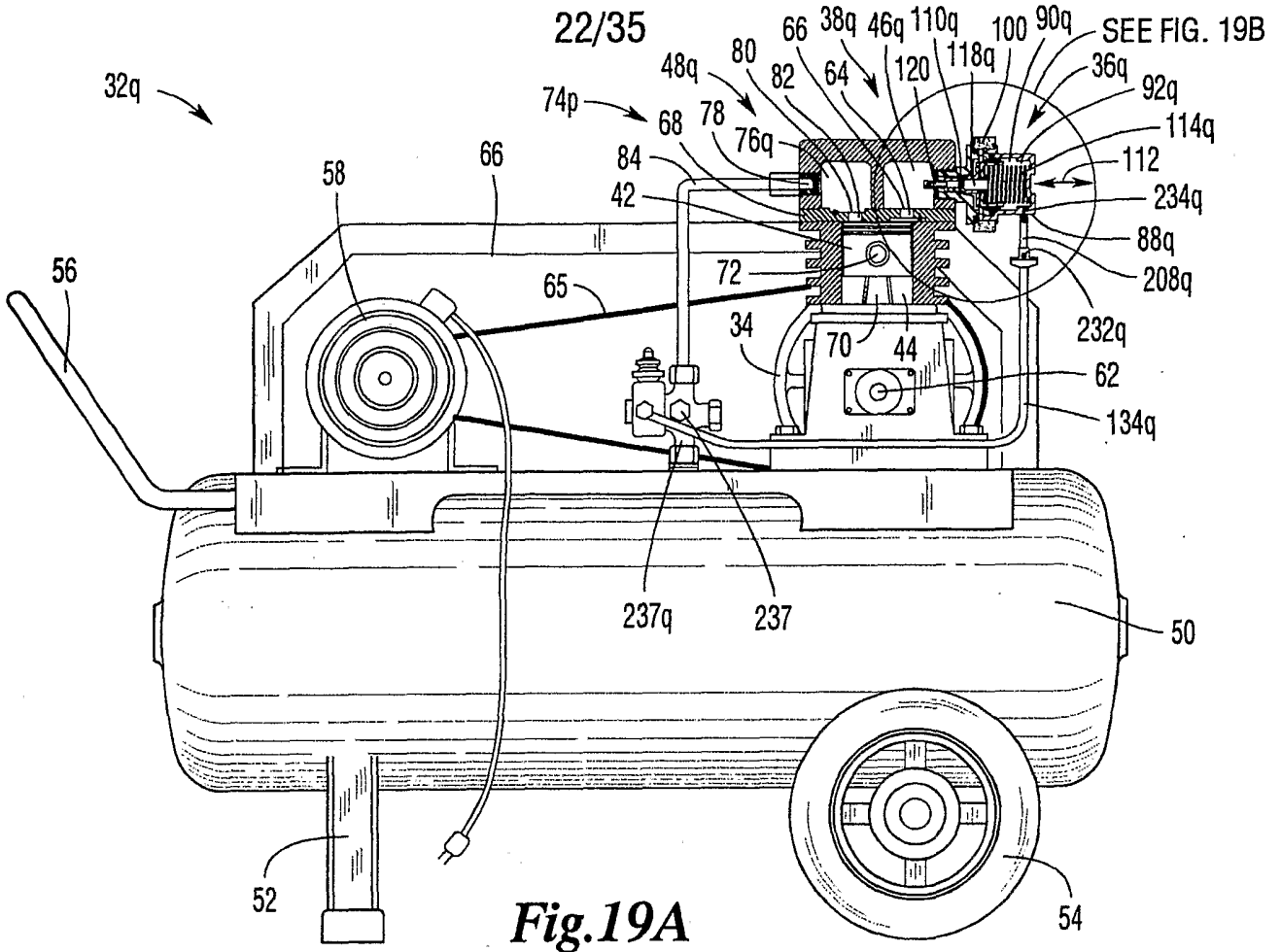


**Fig.17B**

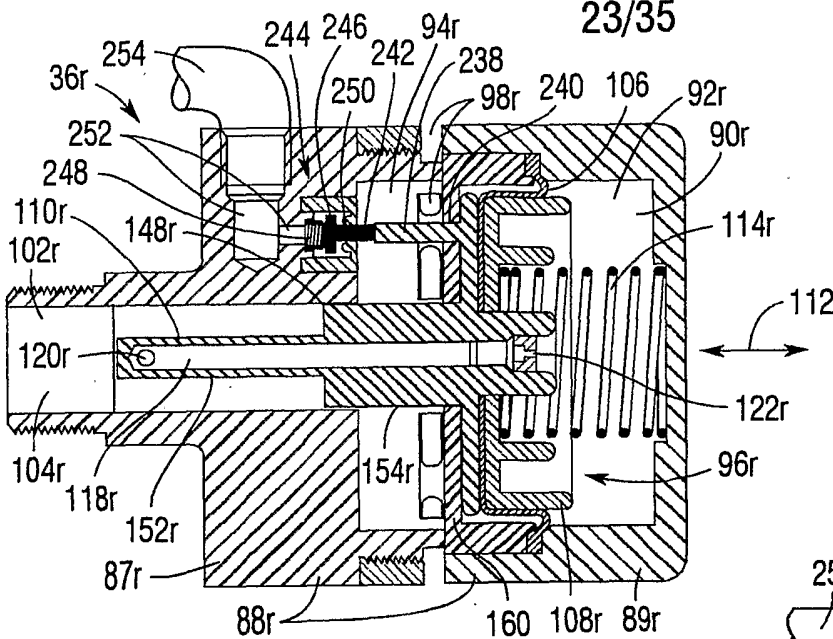


**Fig.17C**

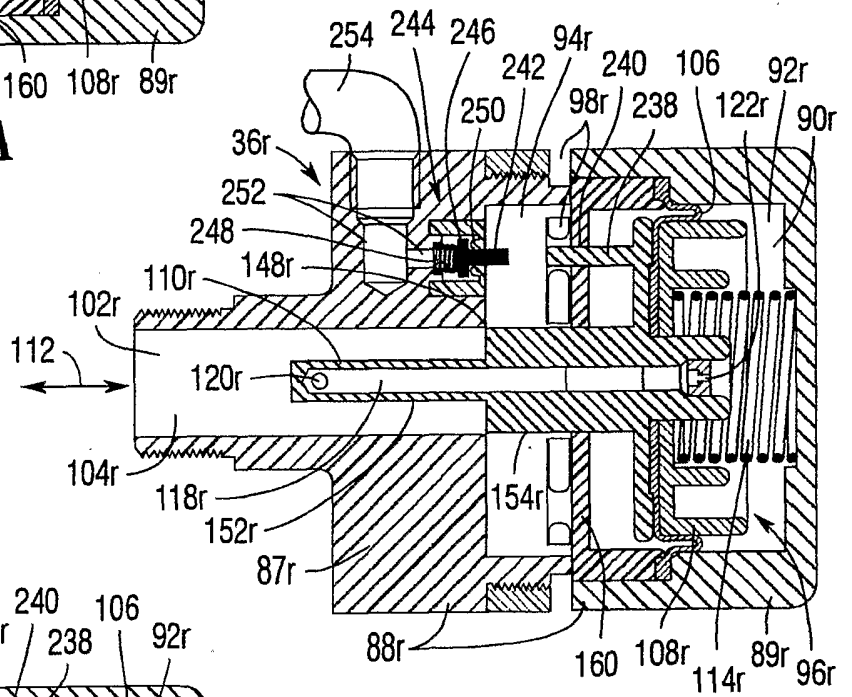




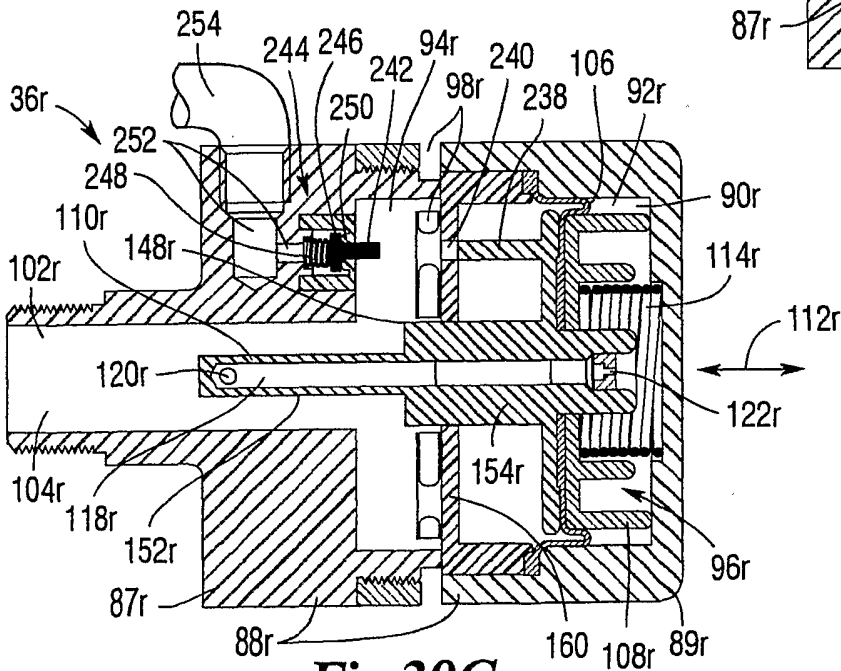
23/35



**Fig. 20A**

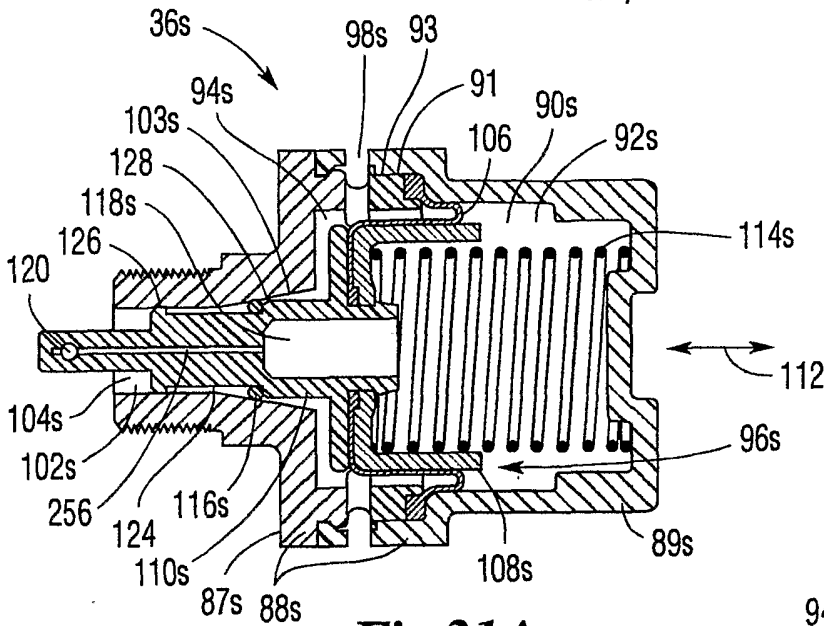


**Fig. 20B**

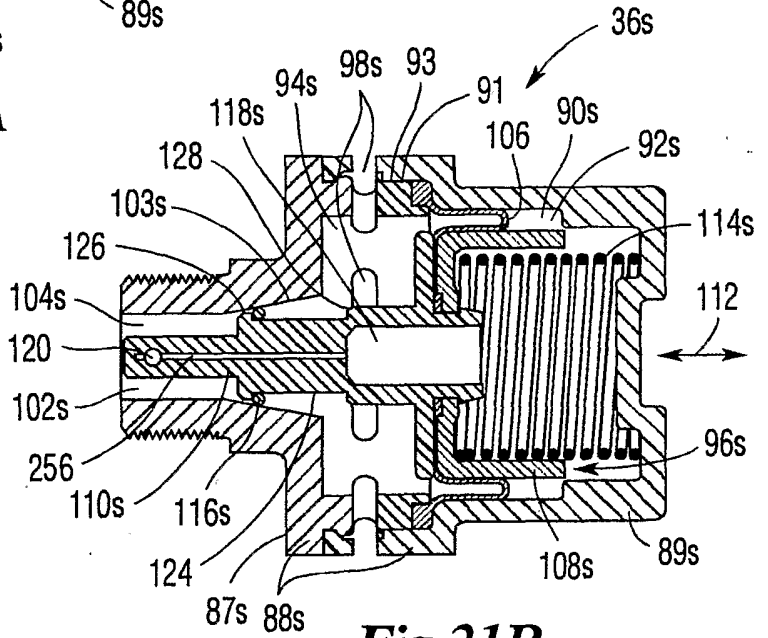


**Fig. 20C**

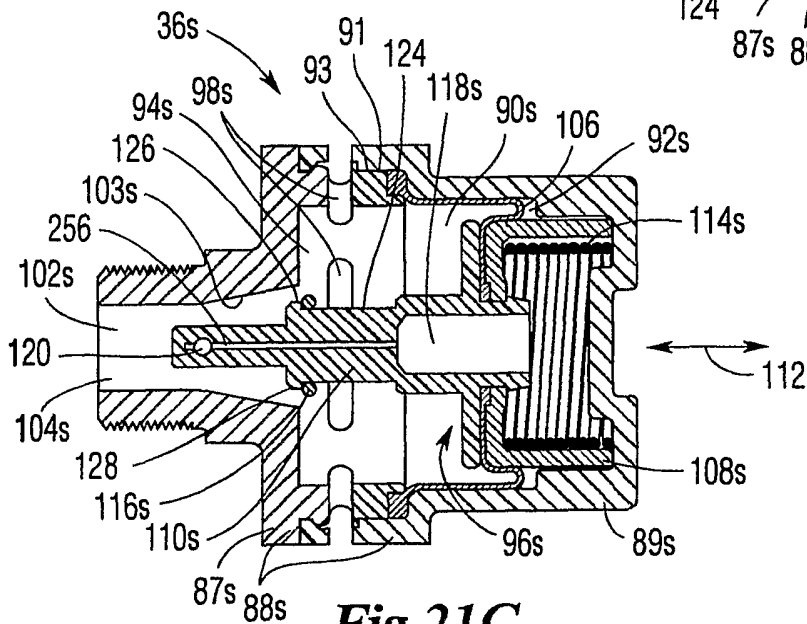
24/35



**Fig. 21A**

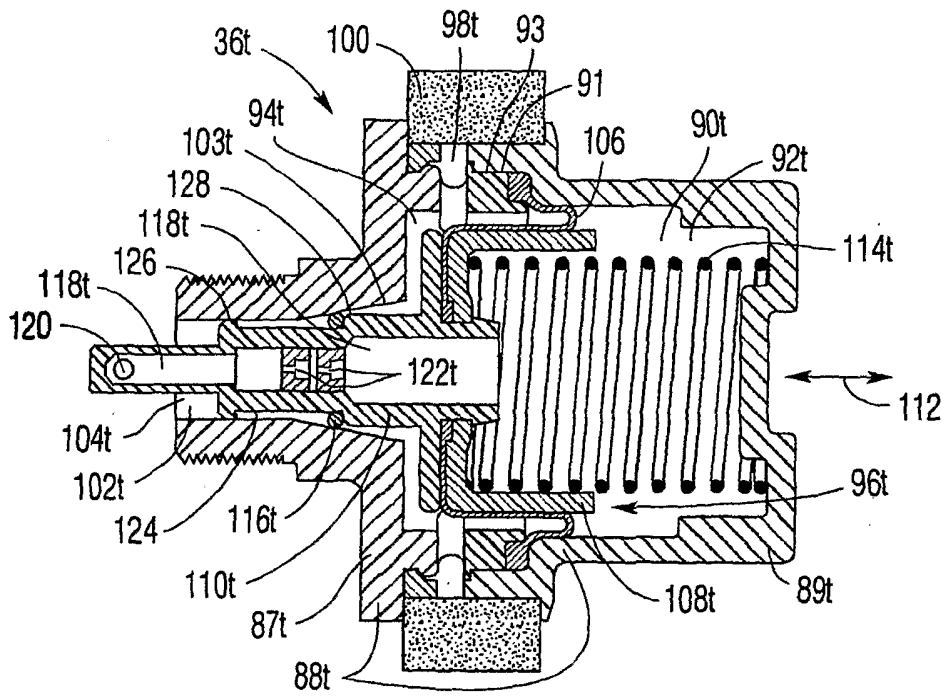


**Fig. 21B**

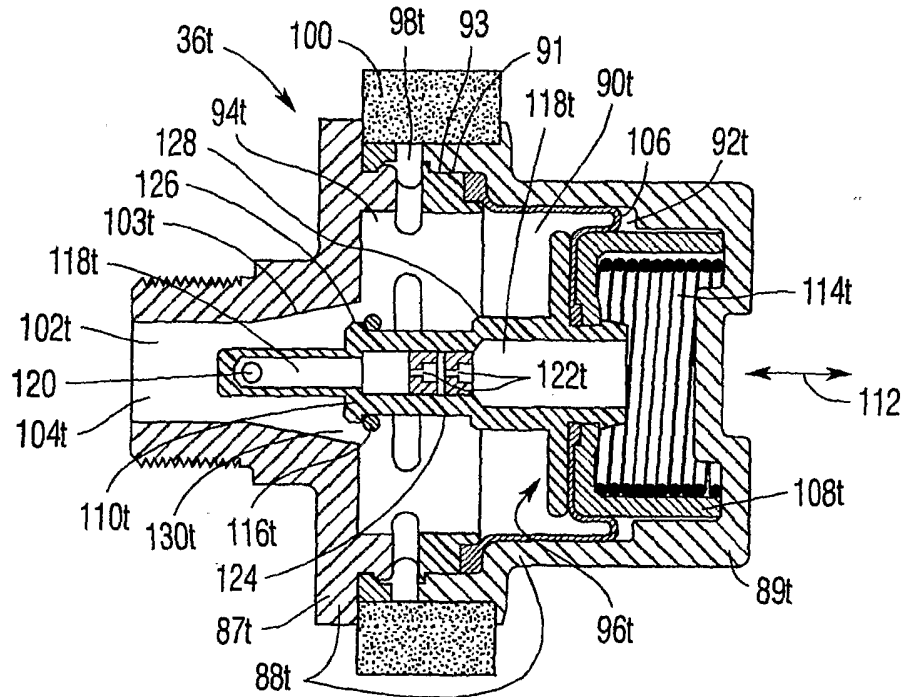


**Fig. 21C**

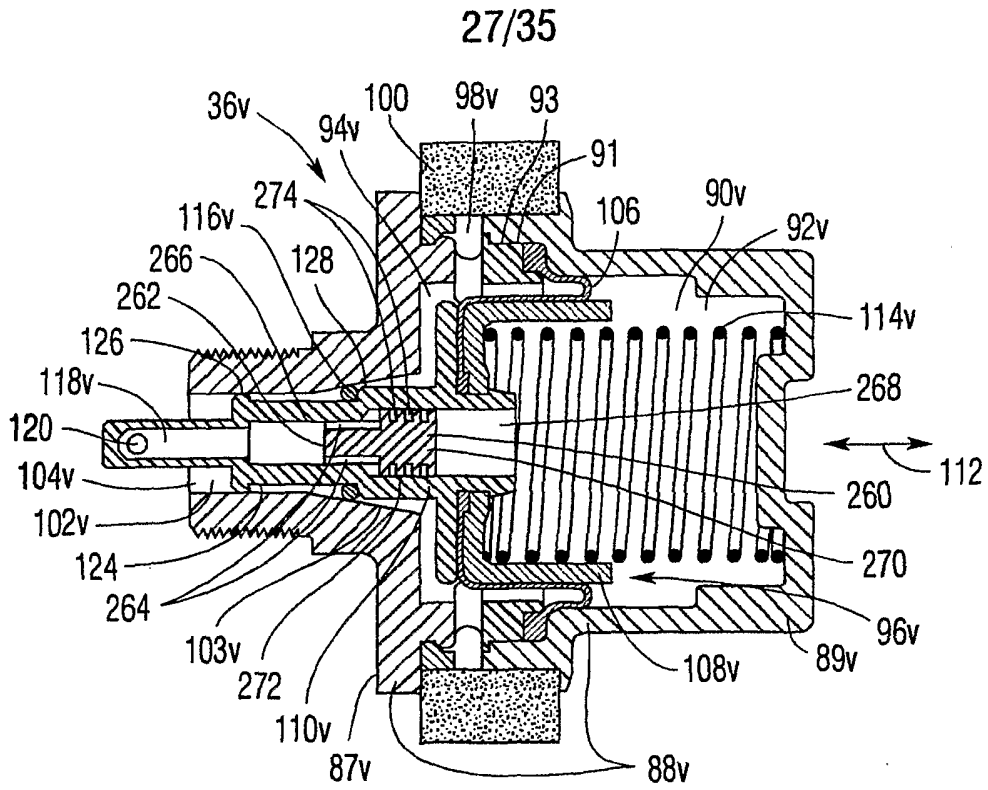
25/35



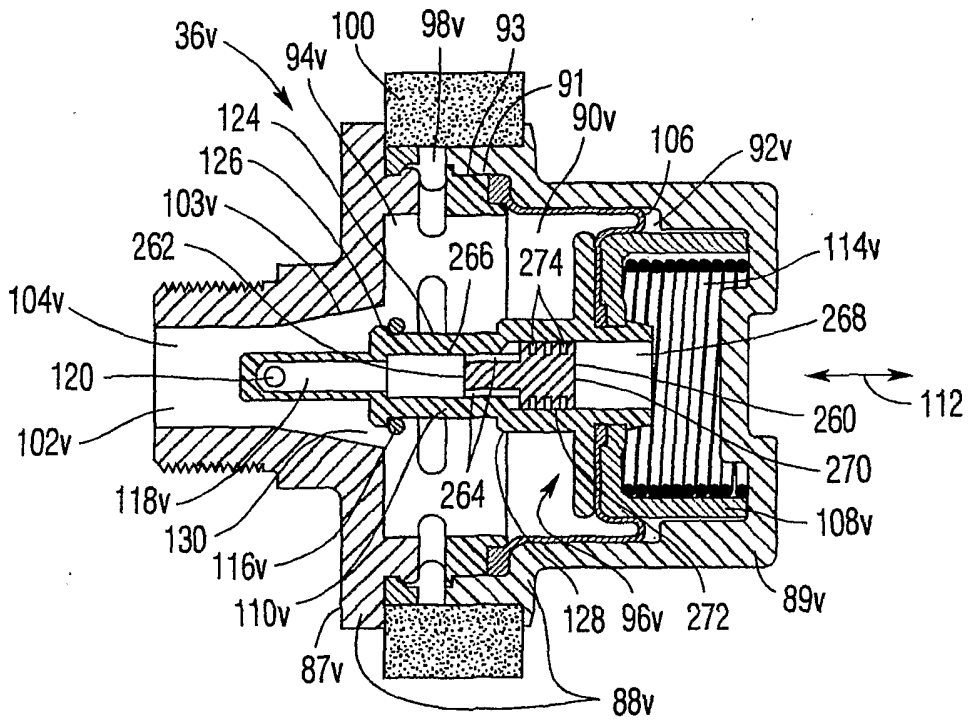
**Fig. 22A**



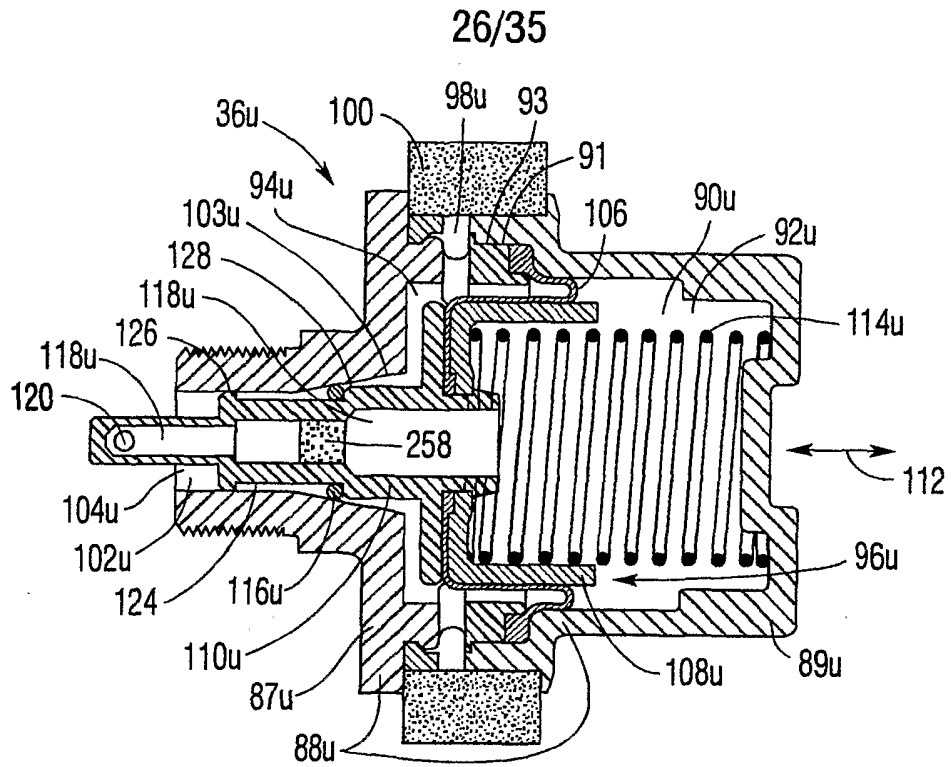
**Fig. 22B**



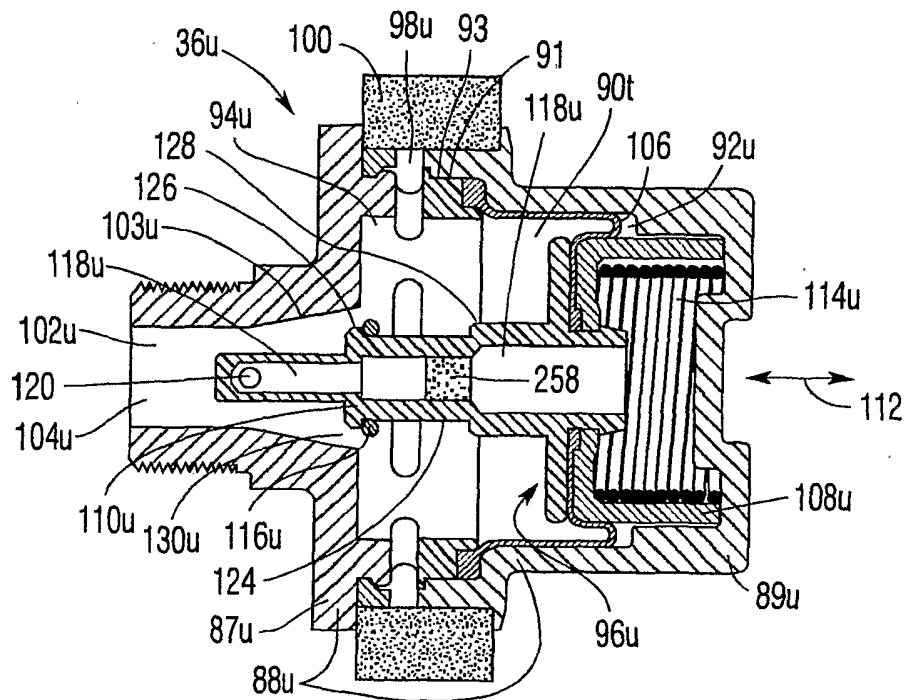
**Fig.24A**



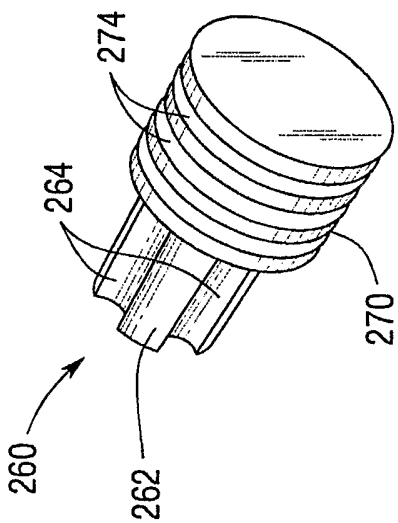
**Fig.24B**



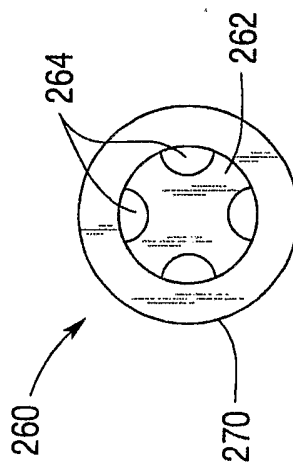
*Fig. 23A*



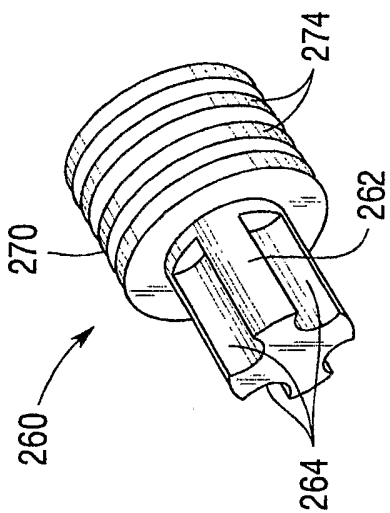
*Fig. 23B*



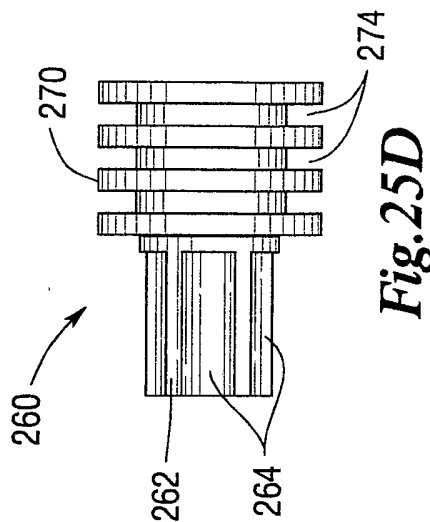
*Fig. 25A*



*Fig. 25B*

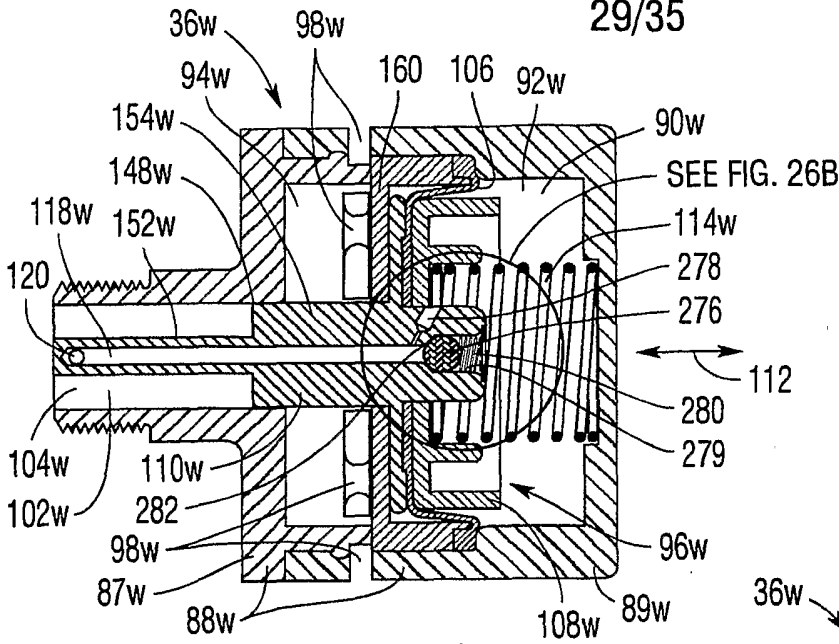


*Fig. 25C*

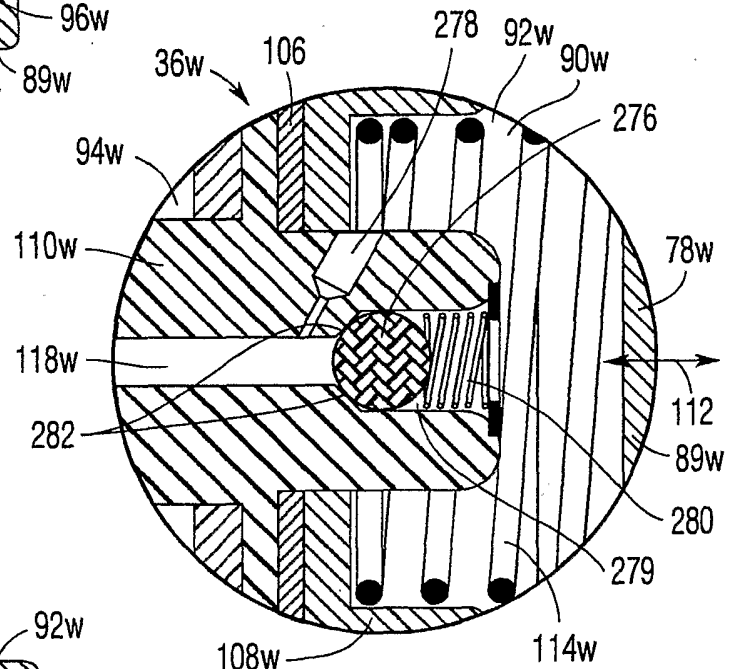


*Fig. 25D*

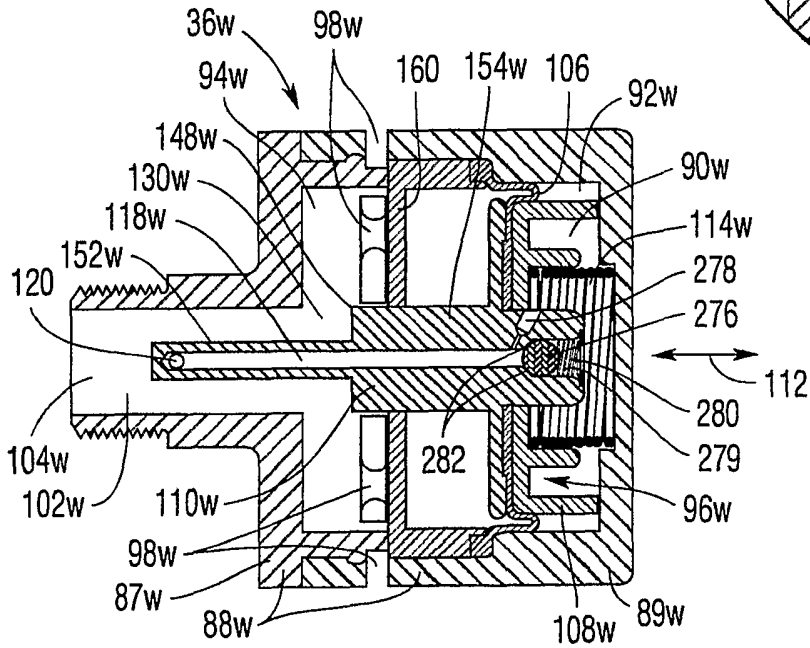
29/35



**Fig. 26A**

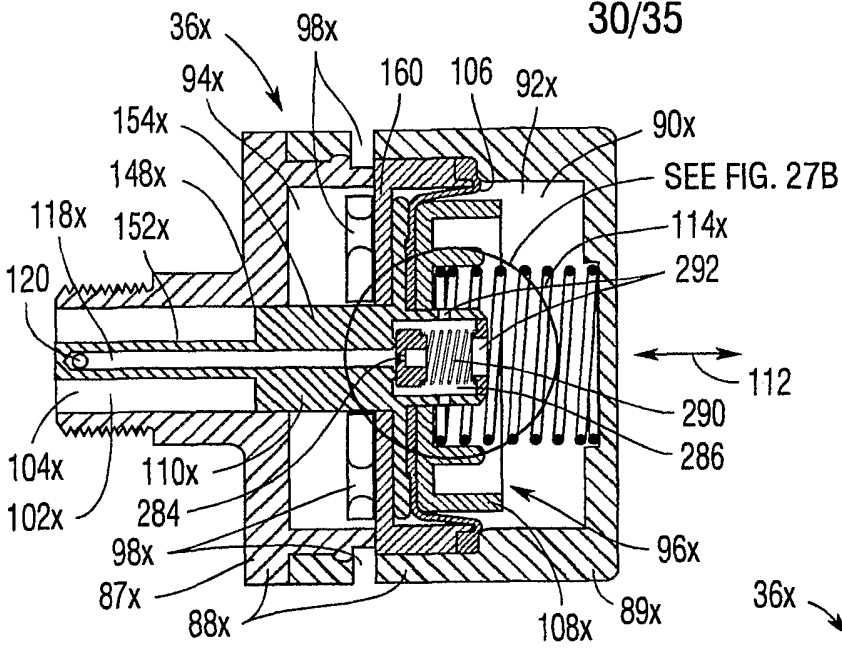


**Fig. 26B**

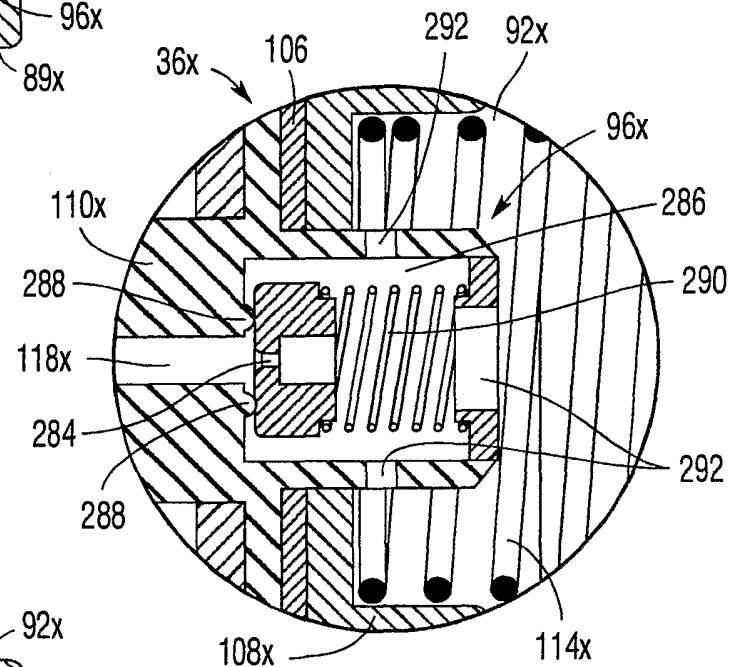


**Fig. 26C**

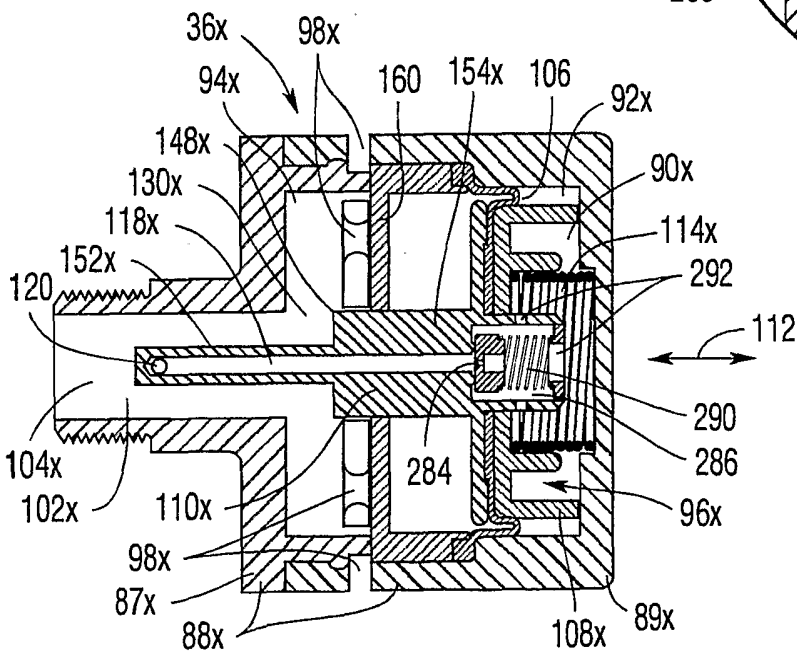
30/35



**Fig.27A**

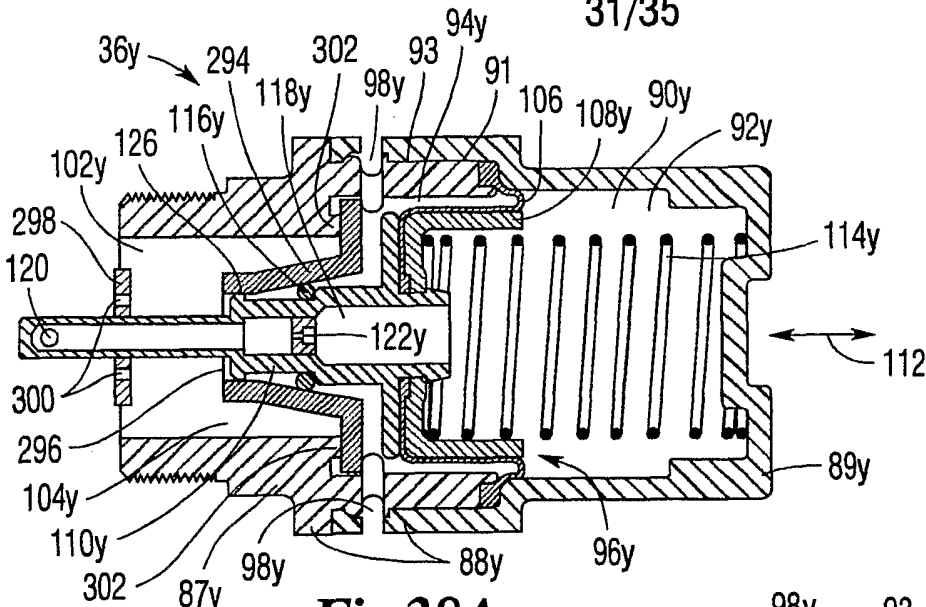


**Fig.27B**

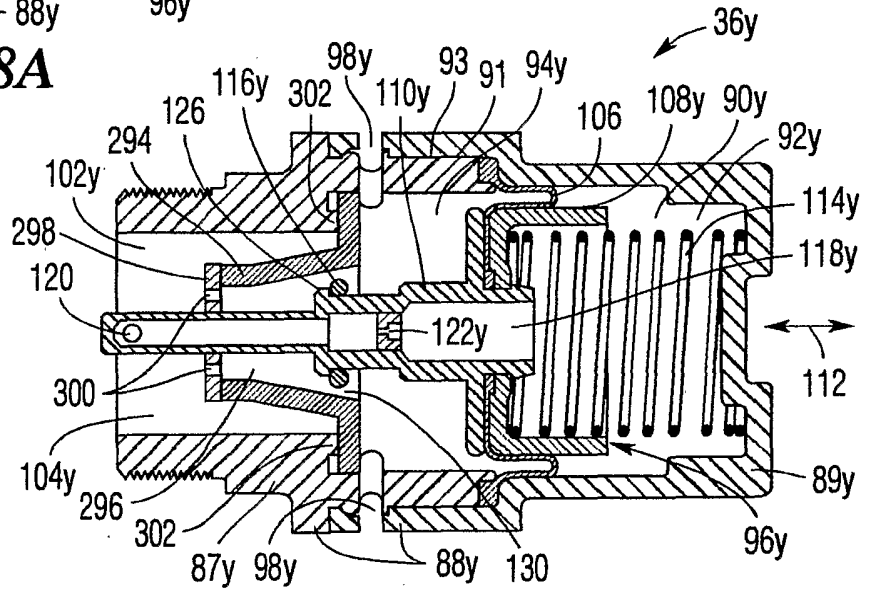


**Fig.27C**

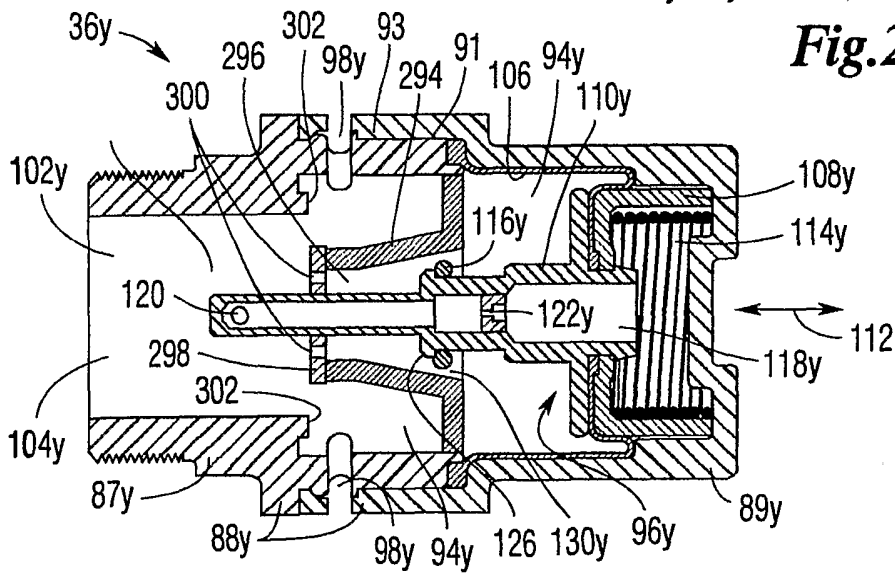
31/35



**Fig. 28A**



**Fig. 28B**



**Fig. 28C**

32/35

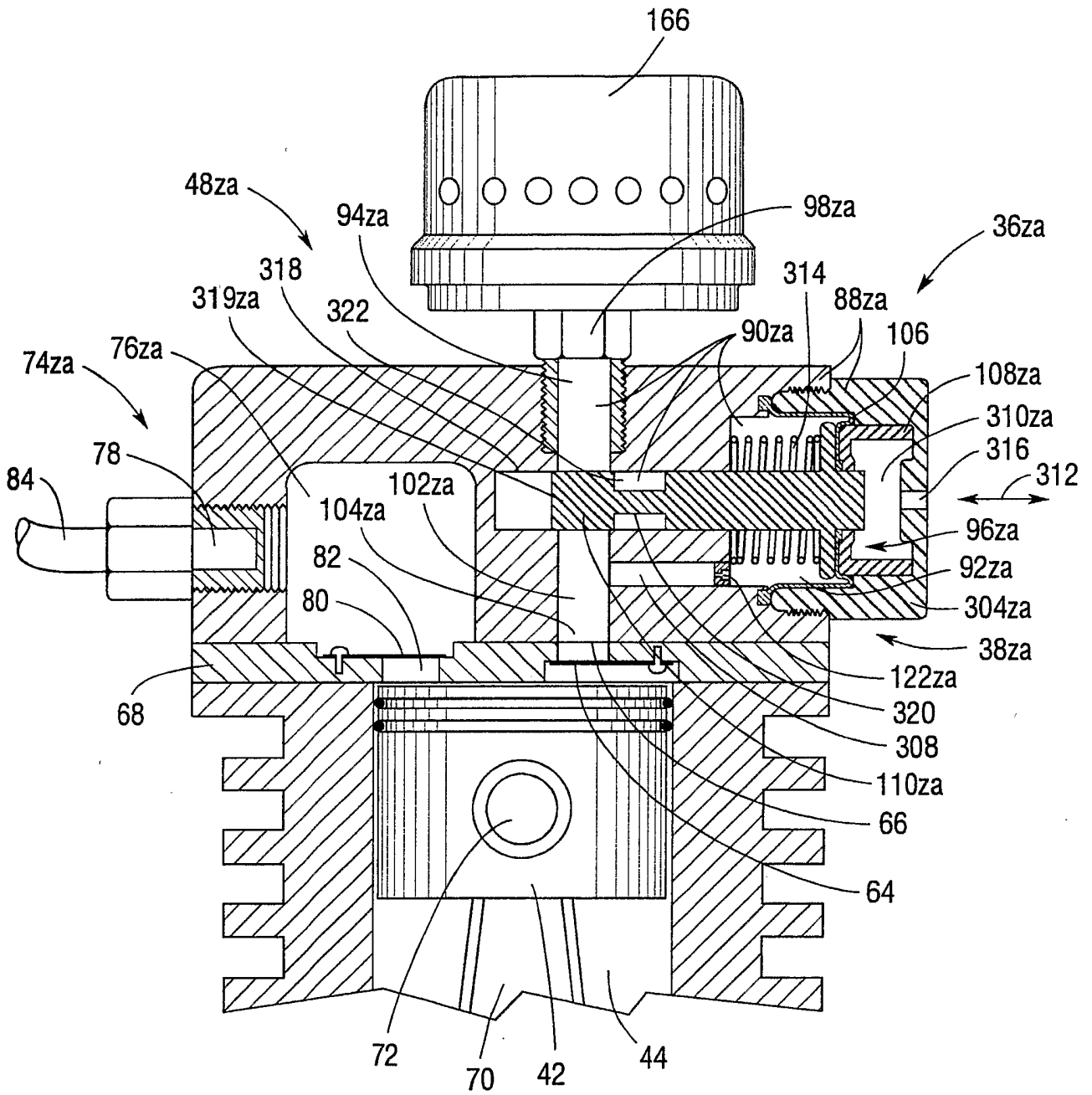
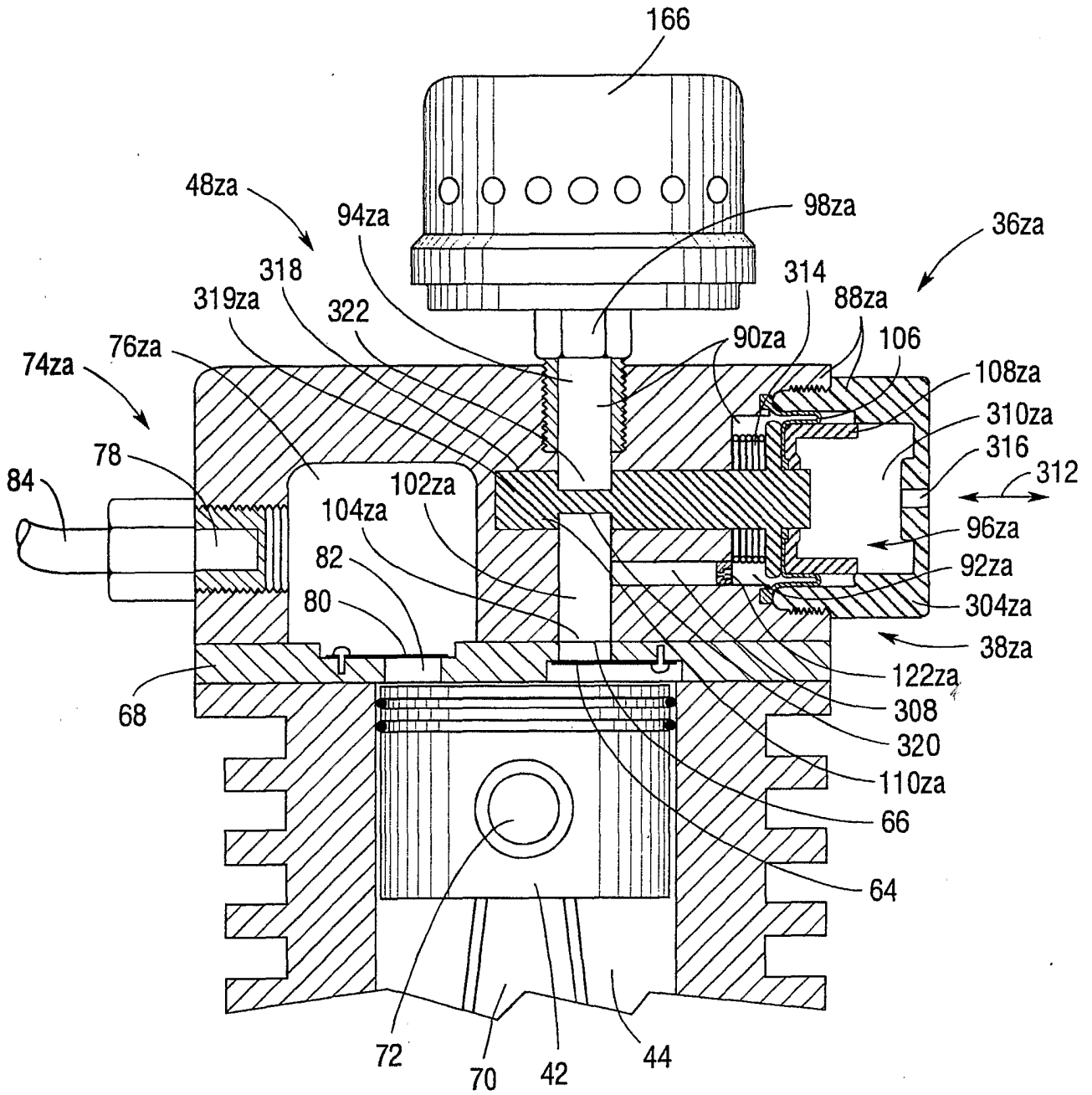


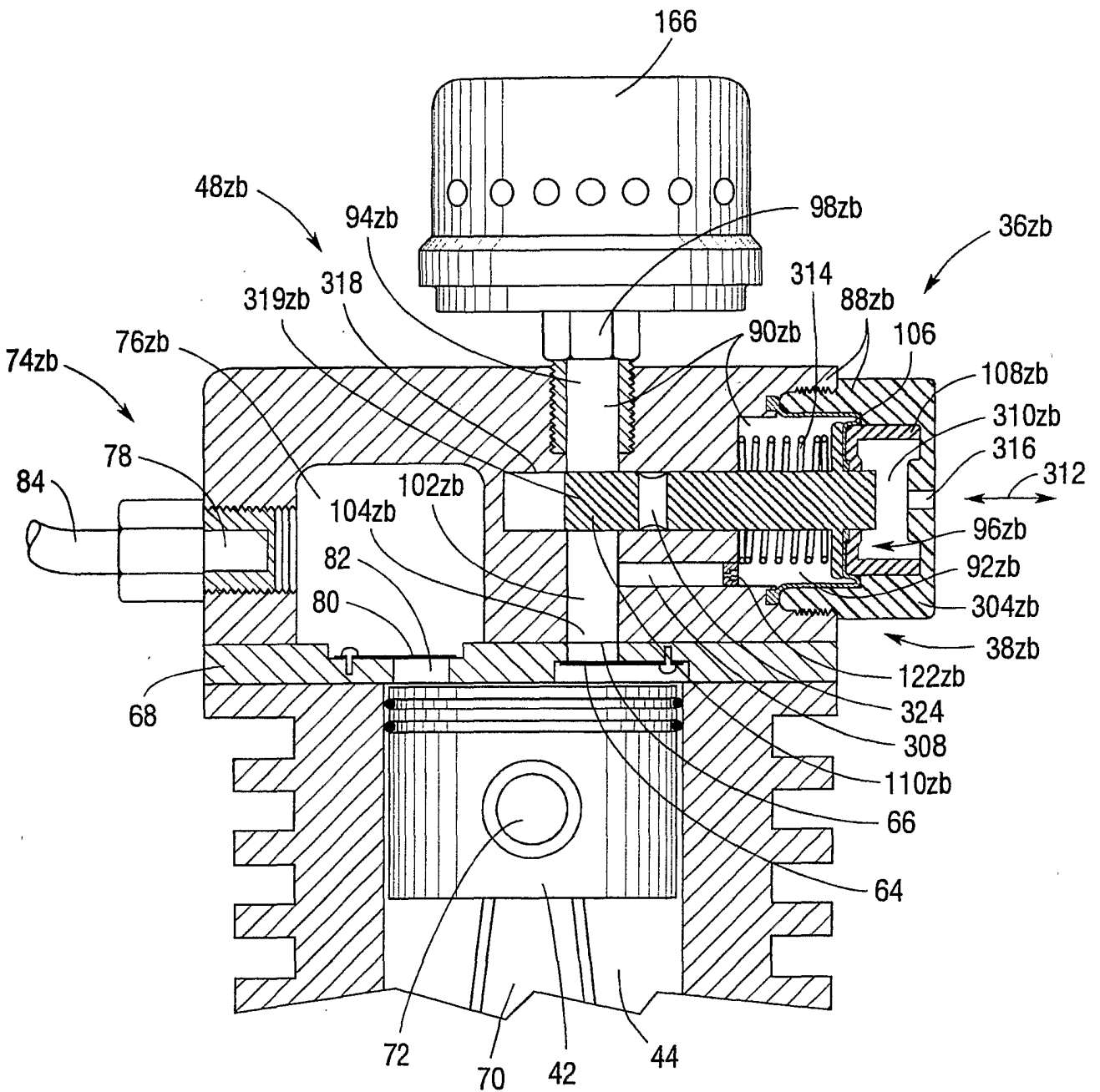
Fig. 29A

33/35



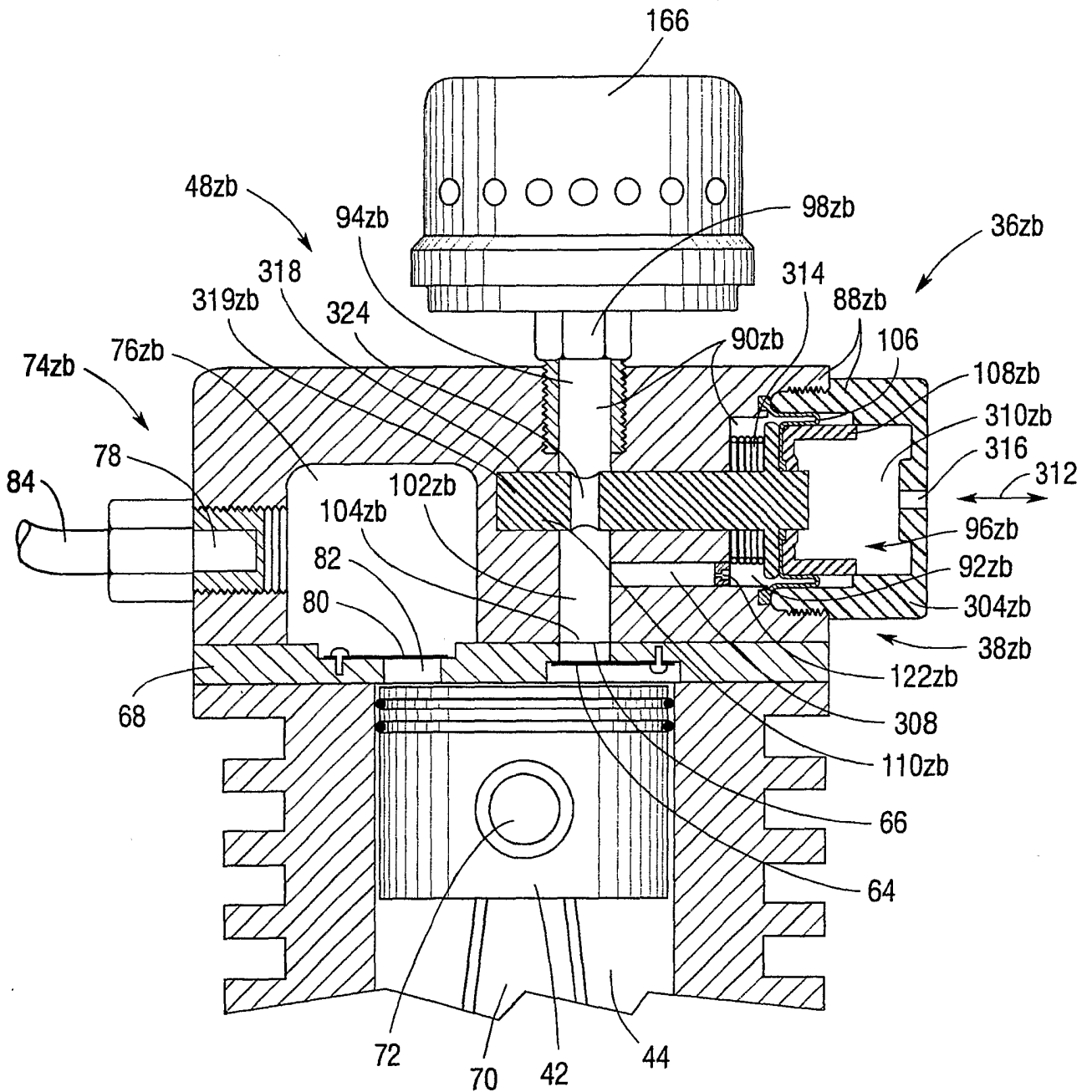
**Fig. 29B**

34/35



**Fig. 30A**

35/35



**Fig.30B**