

L. Knapp,

Curry Comb.

No. 100417.

Patented Mar. 1. 1870.

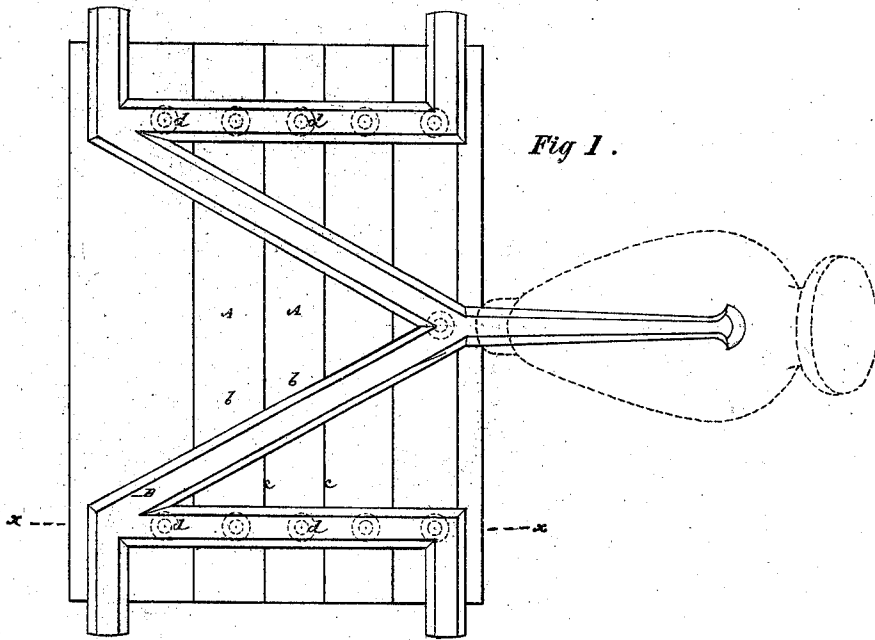

Fig 1.

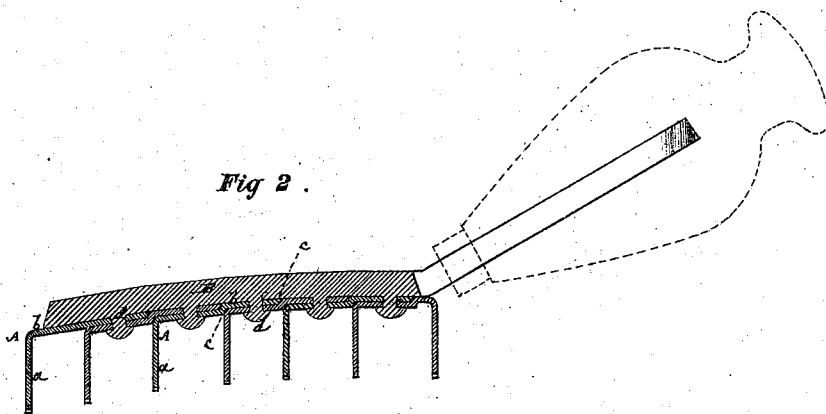

Fig 2.

Witnesses,  
Fred Barnes  
R. H. Babian

Lucien Knapp

# United States Patent Office.

LUCIEN KNAPP, OF WOODHAVEN, NEW YORK.

Letters Patent No. 100,417, dated March 1, 1870.

## IMPROVEMENT IN CURRY-COMBS.

The Schedule referred to in these Letters Patent and making part of the same.

To all whom it may concern:

Be it known that I, LUCIEN KNAPP, of Woodhaven, in the county of Queens, and State of New York, have invented a new and useful Improvement in Curry-Combs, of which the following is a full, clear, and exact description, reference being had to the accompanying drawings forming part of this specification, and in which—

Figure 1 represents a back view of a curry-comb constructed according to my improvement, and

Figure 2 a transverse section of the same, taken as indicated by the line *z z* in figure 1.

Similar letters of reference indicate corresponding parts.

My improvement relates to curry-combs composed of narrow metal strips, bent to form the toothed and back portions of the comb. In such previous constructions the bent longitudinal strips have been made to lap, in a step fashion, one over the other, and have been riveted together direct. This gives an irregular surface to the back, which materially interferes with the riveting of the strips together, by reason of the impossibility of securing a flat or broad and general support to the back while being riveted, and the strips, in the pull or working of the comb when in use, present no check or support to each other in the line of draft, which throws excessive strain on the rivets that unite the strips, irrespectively of the handle or strengthening-ribs connected therewith on the back of the comb.

My invention obviates these difficulties by crooking the back portions of the bent strips so that they present a general flat back surface, and have a shoulder-support, the one against the other, in the line of draft; and I furthermore am enabled to dispense with any separate riveting of the strips together by making rivet projections from the main frame or handle portion, which constitutes a single or entire structure,

answer exclusively for the union of the strips, thereby dispensing with much labor, and cheapening the construction of the comb. The crooks in the back portions of the strips also secure a flat and firm bearing for the main frame of the handle thereon.

Referring to the accompanying drawings—

A A represent the longitudinal narrow metal strips, bent to form toothed portions or strips *a a*, and overlapping back portions *b b*.

These back portions *b* are crooked to form a shoulder, *c*, for support of the strips, the one against the other, in the line of draft, when using the comb, and to secure a general flat, as contradistinguished from a stepped surface to the back, whereby a better bearing is secured for the comb in riveting the strips to the handle or frame B thereof, the ribs of which have rivet projections, *d*, on them, that, passing through holes in the strips, serve to form rivets for uniting the strips together in common with the handle. The flat configuration given to the back of the comb by the crooks *c* formed in the back portions *b*, also secures a better bearing for the main frame B on the strips.

What is here claimed, and desired to be secured by Letters Patent, is—

1. In a curry-comb made up of bent overlapping strips, as described, the crook or shoulder *c* formed in the back portions of the bent strips, substantially as specified.

2. The combination of the bent strips A A, having crooks or shoulders *c c* formed in their back overlapping portions, with the main frame B of the handle united to said plates by rivet projections *d*, essentially as described.

LUCIEN KNAPP.

Witnesses:

FRED HAYNES,  
J. M. DIXON.