

Sept. 12, 1950

W. O. GORDY

2,521,844

ANTENNA

Filed Nov. 16, 1945

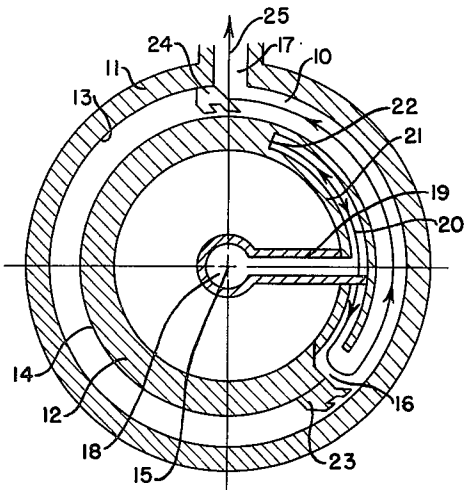

FIG. 1

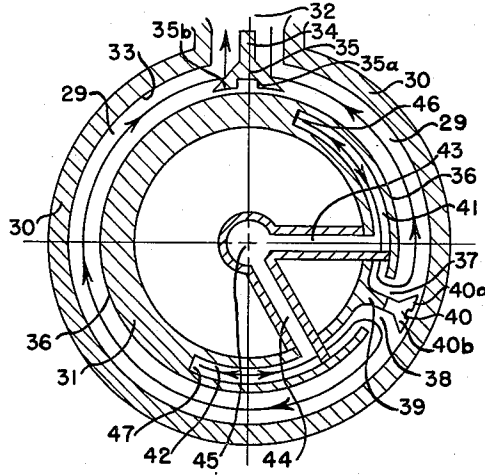

FIG. 2

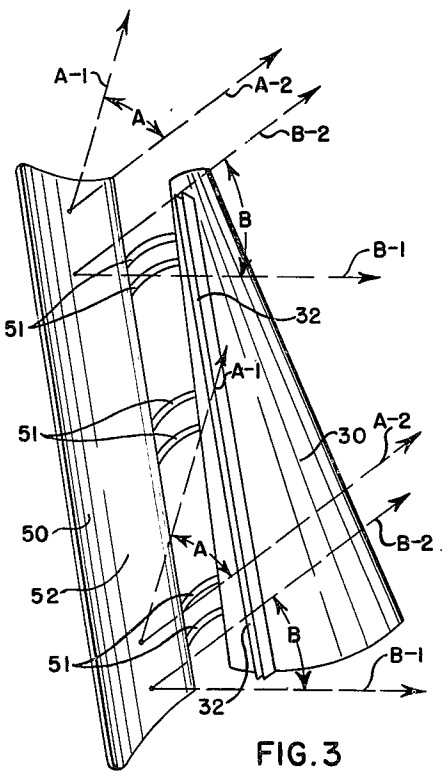

FIG. 3

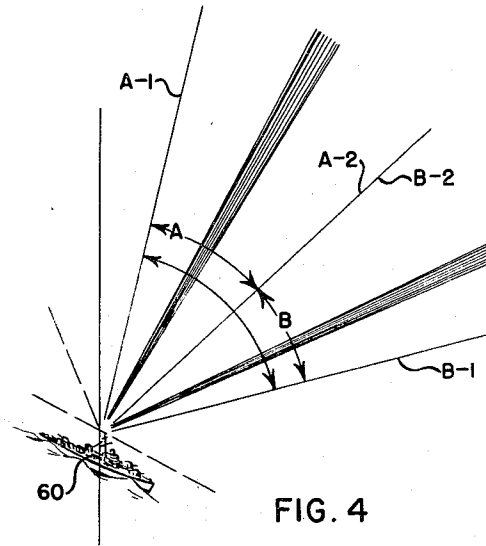

FIG. 4

INVENTOR.
WALTER O. GORDY

BY

William D. Hall

ATTORNEY

UNITED STATES PATENT OFFICE

2,521,844

ANTENNA

Walter O. Gordy, Cambridge, Mass., assignor, by mesne assignments, to the United States of America as represented by the Secretary of War

Application November 16, 1945, Serial No. 629,157

4 Claims. (Cl. 250—33.63)

1

This invention relates to antennas and more particularly to an antenna for scanning defined sectors of space with directed beams of electromagnetic radiation.

Antennas of this general nature, sometimes termed scanners, are frequently utilized in radar (radio echo detection and ranging) systems to radiate electromagnetic energy in a directed narrow beam which scans or recurrently sweeps a defined sector of space linearly with time at a rapid rate. The scanning action may be produced entirely by electrical means, or may be accomplished by mechanical motion, for example by movement of the antenna itself or of an element thereof.

A scanner devised by John S. Foster, application Serial No. 657,156, filed March 26, 1946, to which the instant invention is related, employs what may be termed a conical shell waveguide and is hereinafter briefly considered in order to better describe the present invention.

In the Foster scanner, only a single beam of electromagnetic radiation is emitted at any one time. The present invention is an improvement thereon whereby two scanning beams of electromagnetic energy may be simultaneously directed from the one antenna system.

Among the objects of this invention are: to provide a single conical shell waveguide antenna which will scan two defined sectors of space separately and simultaneously; and to provide a conical shell waveguide scanner which is compact in structure and light in weight, considering the large sectors of space swept by the scanner.

Further objects and other advantages and novel features of this invention will become apparent from the description contained herein taken with the drawings accompanying this specification, in which:

Fig. 1 is a cross-sectional view of a Foster conical shell waveguide scanner;

Fig. 2 is a cross-sectional view of a preferred embodiment of the present invention;

Fig. 3 illustrates in perspective the external appearance of the waveguide scanner of the invention; and

Fig. 4 illustrates the geometry applicable to a radar system employing the present invention.

Referring now to Fig. 1, there is illustrated a cross-sectional view of a conical shell waveguide scanner as developed by John S. Foster. The cross-sectional view is taken in a plane perpendicular to the axis of a conical shell waveguide 10, approximately midway along the axis in the

2

region where a conventional waveguide transmission line connects to an inner member of the scanner. The conical shell waveguide is formed by outer and inner members 11 and 12 providing substantially parallel outer and inner conical surfaces 13 and 14, respectively. The separation between surfaces 13 and 14 is preferably less than one-half wavelength at the contemplated operating frequencies. In the described embodiment of this Foster scanner, member 11 is stationary, and member 12 is rotatable about axis 15 of coaxial conical surfaces 13 and 14. A longitudinal aperture 16 is provided in the inner or rotor member 12, as shown, extending substantially along linear elements of conical surface 14. A similar longitudinal aperture 17 is provided in outer member 11, extending substantially along linear elements of conical surface 13.

Energy may be introduced to the system through a waveguide 18 extending coaxially into the rotor member of the structure and communicating with a branching waveguide 19. Energy may be fed into or extracted from the rotor member by use of a rotating joint, not shown, provided at one end of waveguide 18. Waveguide 19 is secured to the rotor member 12, and at that member has a terminating aperture 20 adapted to feed electromagnetic energy to a parabolic pillbox 21 contained within the rotor member.

The structure and function of parabolic pillbox 21 may be understood by considering a waveguide structure having two parallel planar surfaces, preferably separated by less than one-half wavelength, between which wave energy may be directed toward a third reflecting surface shaped in the form of a parabolic cylinder of comparatively small height. Wave energy directed into such a structure toward the reflecting surface, from the neighborhood of the focal line defined by the parabolic surface, will be reflected with a wave front normal to the axial plane of the parabolic surface. Pillbox 21 is such a structure, except that here its curved surfaces are curved or deformed, in order to fit within rotor 12 and in order to provide an emanating wave front at longitudinal aperture 16 which corresponds with the open end termination of pillbox 12. The emanating wave front at aperture 16 may be substantially parallel to the line elements of conical surface 14 at aperture 16. The feed aperture 20 of waveguide 19 is located in the neighborhood of the focal point of the parabolic reflecting surface 22 of pillbox 12.

A series of teeth 23, adapted to reflect or direct

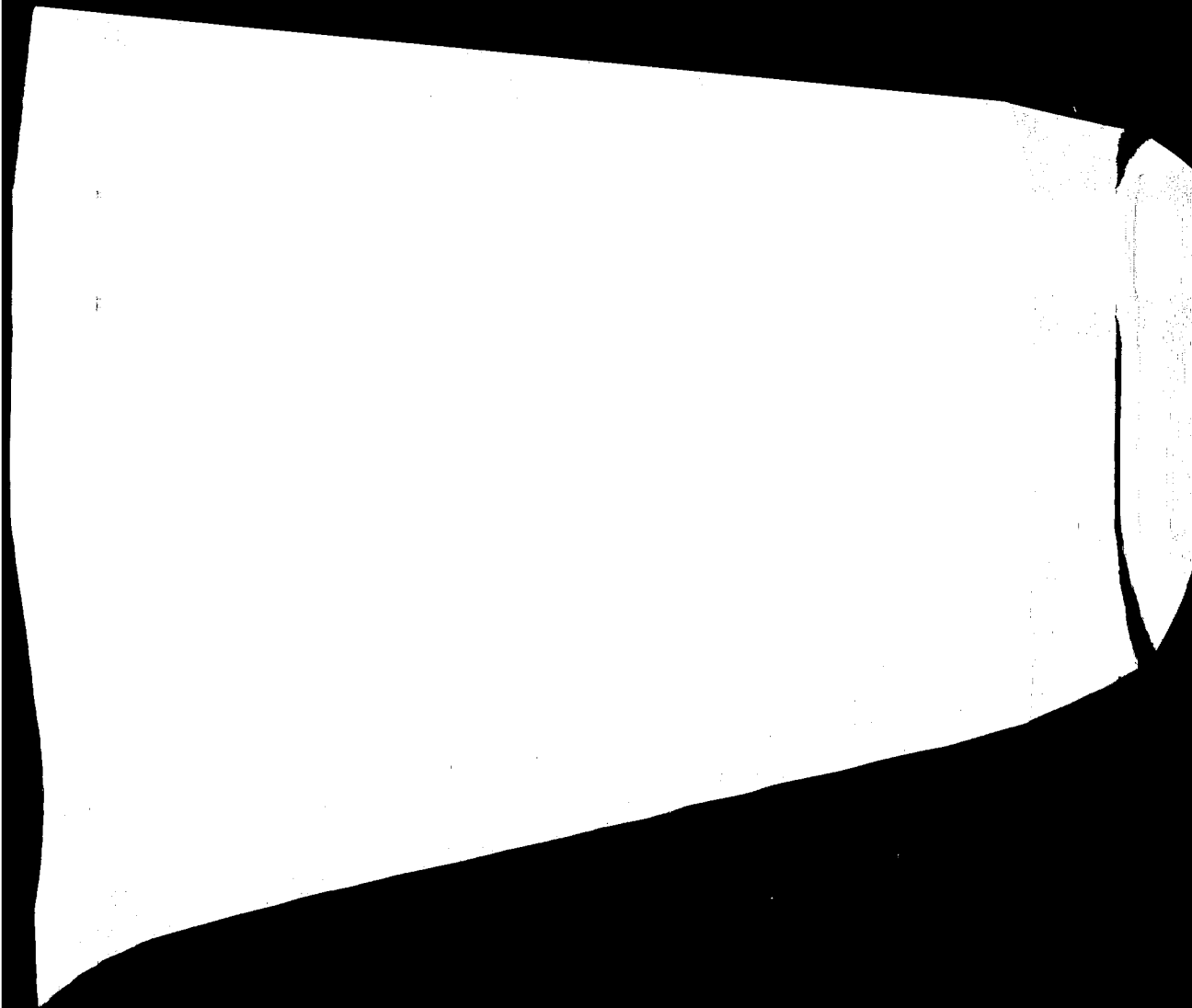

5

clockwise direction and is reflected into aperture 32 by reflecting teeth 35a; likewise, electromagnetic energy fed from branching waveguide 44 to pillbox 42 is directed by reflecting teeth 40b into conical shell waveguide 29, traveling clockwise therethrough until directed out of aperture 32 by reflecting teeth 35b. As inner member 31 of the structure is rotated, electromagnetic energy emanates from aperture 32 in two separate beams which recurrently scan, in the same plane, sectors which have substantially equal angles in the embodiment illustrated. The salient members 35 and 40 are arranged to slip past each other so that continuous rotation may be achieved. If desired, two separate apertures may be utilized for the transmission of energy from waveguide 29, instead of using an aperture divided by a partition, as shown. Similarly, two angularly separated apertures may be utilized for the transmission of energy into conical waveguide 29, rather than using adjacent apertures 37 and 38 as in the embodiment herein disclosed. It will be understood that arranging the apertures and reflectors as shown, however, permits use of a single reflector illuminated by the energy from both apertures.

Referring now to Fig. 3, there is illustrated in perspective the external appearance of the conical shell waveguide scanner of Fig. 2, like parts having like reference numerals applied thereto. The outer surface of member 30 may be conical in shape to conform to its inner surface 33. An auxiliary reflector may be used to increase the effective gain of the antenna system. Thus, a parabolic cylinder reflector 50 may be utilized, held in fixed relation to the scanner structure proper by members 51 as shown. Reflecting surface 52 of the parabolic cylinder reflector 51 may have its focal axis substantially along the line of aperture 32. Such a portion of the parabolic cylinder surface may be used that the reflected electromagnetic waves travel outwardly therefrom in a plane spaced from and parallel to the axial plane of the parabolic cylinder, so that the conical waveguide scanner may be in a non-interfering position relative to the reflected beams.

The conical waveguide scanner of Fig. 2 may be constructed so that the two radiated beams may scan separate sectors, as angle A and angle B of Fig. 3. This result may be accomplished in the embodiment herein disclosed by suitably orienting the structure of pillboxes 41 and 42 within the rotor member 31. If linear arrays, lens systems, or other means are utilized for providing electromagnetic energy having plane wave fronts at longitudinal apertures in the inner surface of the conical shell waveguide, a similar effect may be accomplished by proper phasing or alteration of the elements thereof.

It will be assumed, as before, that rotor member 32 turns in a clockwise direction as seen in Fig. 2 of the drawing.

Referring again to Fig. 3, lines A—1 and A—2 respectively indicate, for the two positions of the rotor wherein salient members 40 are positioned immediately clockwise and counterclockwise, respectively, relative to salient members 35, the directions which may be taken by energy which has traveled in a counterclockwise direction through waveguide 30. Similarly, lines B—1 and B—2 respectively indicate the directions which may be taken by energy which has traveled in a clockwise direction through wave guide 29.

Thus the cycle of scan for sectors A and B in the disclosed embodiment starts with the beams

6

in positions A—1 and B—1, the beams sweeping toward the positions A—2 and B—2 during the scanning cycle, and starting again from positions A—1 and B—1 at the beginning of the next scanning cycle.

The utility of such a two-sector scanning structure may be understood by reference to Fig. 4 which illustrates the geometry of a radio echo detection and ranging system using the conical shell waveguide scanner herein disclosed. A vessel 60 is diagrammed navigating surface waters. The structure illustrated in Fig. 3 may be mounted on vessel 60 with aperture 32 and reflector 50 in a generally vertical position. In Fig. 4 are diagrammed the sectors having angles A and B. It will be observed therefrom that the beam of energy sweeping sector B may start along a line B—1, which is substantially horizontal, and sweep through a sector B. Similarly, the other beam may start along a substantially vertical line A—1 and sweep through a sector A having a like angle. At the completion of a scanning cycle, the two beams may be substantially codirectional, as shown. The antenna structure may be revolved in azimuth to obtain coverage of an entire segment of space about vessel 60. The system described may thus simultaneously satisfy in general the requirements of both a long-range and short-range system, for the beam sweeping the lower elevation sector B can carry greater power, or greater antenna gain, than that sweeping the higher elevation sector A. (In practical radar systems, far-distant targets, requiring greater radar power for their detection, reasonably appear only at low elevation angles.) It may be more convenient to use approximately equal power outputs for both beams, and adjust the pillboxes to suitable sizes so that a minimum cone length may be used for the scanner. It is apparent that considerable saving in space and weight may thus be accomplished by use of the present invention. A further advantage resides in the complete coverage of the total angle A plus B, which is otherwise difficult to secure.

In a radar system utilizing the antenna structure here described, echoes returned from distant objects may be located in elevation by their timed relationship to the period of the scan. The scanning is linear with the rotation of the rotor, so that with the rotor turned at a constant speed, the angular displacements of the beams are linear with time. Consequently, such timed relationship may be established through the use of linear sweep circuits, as well as other means, synchronized with the rotor rotation. Moreover, signals returning from both beams may be simultaneously displayed on a single oscilloscope designed to display the signal range as plotted against elevation angle.

Although the description and discussion of the conical waveguide scanner has here been considered from the viewpoint only of energy radiated from the scanner it will be apparent to those skilled in the radio art that the scanner is a linear device, which will transmit energy equally well in a reverse direction with like directive qualities. In other words, as already assumed in connection with the discussion of Fig. 4, where signals are both sent and received by the radar system antenna, the conical shell wave guide scanner of the invention may be used equally well and with like directive qualities for either transmission or reception of electromagnetic energy.

The scanner of this invention may also be de-

signed to cause the two beams of energy to scan the same sectors, so that the scanning angle is covered by both beams crossing each other. This design might be useful in locating by radar a hidden source of shell fire by observing the echoes returned at angles which indicate the path or orbit of the projectile. The present invention thus affords a convenient means for providing a double beam to satisfy the requirements of many electromagnetic radiation systems.

Variations in the structure herein described as an embodiment of the invention will be apparent to those skilled in the radio and waveguide arts. Therefore it is not desired to restrict the invention to the precise embodiment herein disclosed, nor to the particular usage herein described.

What is claimed is:

1. A waveguide structure for electromagnetic energy, including inner and outer members defining a substantially conical shell waveguide, said inner member providing the inner surface of said conical shell waveguide and having two longitudinal inner apertures therein, said outer member providing the outer coaxial surface of said conical shell waveguide and having two longitudinal outer apertures therein, inner surface energy-directing members arranged between said inner apertures and extending into said conical shell waveguide from said inner member, and outer surface energy-directing members

arranged between said outer apertures and extending into said conical shell waveguide from said outer member, whereby energy may be transferred between each of said inner surface apertures and a corresponding outer surface aperture circumferentially through said conical shell waveguide.

2. The waveguide structure of claim 1 wherein said inner member and its energy-directing members are rotatable about the common axis of said coaxial surfaces, and wherein said energy-directing members are in the form of teeth adapted to slip past each other upon rotation of said inner member.

3. The waveguide structure of claim 1, further including means for rotating said inner member about the common axis of said coaxial surfaces.

4. The waveguide structure of claim 1, further including means within said inner structure for transferring energy through said inner apertures.

WALTER O. GORDY,

REFERENCES CITED

The following references are of record in the file of this patent:

UNITED STATES PATENTS

Number	Name	Date
2,402,622	Hansen	June 25, 1946