



## INTERNATIONAL APPLICATION PUBLISHED UNDER THE PATENT COOPERATION TREATY (PCT)

<p>(51) International Patent Classification <sup>7</sup> : <b>A61F 2/00</b></p>	<p><b>A1</b></p>	<p>(11) International Publication Number: <b>WO 00/67662</b></p> <p>(43) International Publication Date: 16 November 2000 (16.11.00)</p>
<p>(21) International Application Number: PCT/US00/12515</p> <p>(22) International Filing Date: 9 May 2000 (09.05.00)</p> <p>(30) Priority Data: 09/309,575 11 May 1999 (11.05.99) US</p> <p>(71) Applicant: INTERNALLY YOURS, LLC [US/US]; 1421 State Street, Suite B, P.O. Box 1470, Santa Barbara, CA 93102-1470 (US).</p> <p>(72) Inventors: HUSETH, Dorothy; 3951 Mesa Circle Drive, Lompoc, CA 93436 (US). GLUCK, Clifford; 137 Hinckley Road, Milton, MA 02186 (US). GLUCK, David, L.; 2124 Bath Street, Santa Barbara, CA 93105 (US).</p> <p>(74) Agents: FINKELSTEIN, Jay, M. et al.; Pillsbury, Madison &amp; Sutro LLP, 1100 New York Avenue, N.W., Washington, DC 20005 (US).</p>		<p>(81) Designated States: AE, AG, AL, AM, AT, AU, AZ, BA, BB, BG, BR, BY, CA, CH, CN, CR, CU, CZ, DE, DK, DM, DZ, EE, ES, FI, GB, GD, GE, GH, GM, HR, HU, ID, IL, IN, IS, JP, KE, KG, KP, KR, KZ, LC, LK, LR, LS, LT, LU, LV, MA, MD, MG, MK, MN, MW, MX, NO, NZ, PL, PT, RO, RU, SD, SE, SG, SI, SK, SL, TJ, TM, TR, TT, TZ, UA, UG, UZ, VN, YU, ZA, ZW, ARIPO patent (GH, GM, KE, LS, MW, SD, SL, SZ, TZ, UG, ZW), Eurasian patent (AM, AZ, BY, KG, KZ, MD, RU, TJ, TM), European patent (AT, BE, CH, CY, DE, DK, ES, FI, FR, GB, GR, IE, IT, LU, MC, NL, PT, SE), OAPI patent (BF, BJ, CF, CG, CI, CM, GA, GN, GW, ML, MR, NE, SN, TD, TG).</p> <p><b>Published</b> <i>With international search report. Before the expiration of the time limit for amending the claims and to be republished in the event of the receipt of amendments.</i></p>
<p>(54) Title: AN INTRAVAGINAL SUPPORT ABSORBENT MATERIAL URINARY INCONTINENCE DEVICE</p>		
<p>(57) Abstract</p>		
<p>An intravaginal absorbent urinary incontinence device for the prevention of involuntary urination includes an absorbent pessary member (2) for absorbing urinary leakage, at least one structure (4) carried by the member for supporting at least one of the bladder neck and bladder, when the member is inserted in the vaginal canal. A process for preventing involuntary urination by supporting at least one of the bladder neck and bladder with an intravaginal absorbent urinary incontinence device while concurrently absorbing urinary spillage with an intravaginal absorbent pessary member.</p>		

*FOR THE PURPOSES OF INFORMATION ONLY*

Codes used to identify States party to the PCT on the front pages of pamphlets publishing international applications under the PCT.

AL	Albania	ES	Spain	LS	Lesotho	SI	Slovenia
AM	Armenia	FI	Finland	LT	Lithuania	SK	Slovakia
AT	Austria	FR	France	LU	Luxembourg	SN	Senegal
AU	Australia	GA	Gabon	LV	Latvia	SZ	Swaziland
AZ	Azerbaijan	GB	United Kingdom	MC	Monaco	TD	Chad
BA	Bosnia and Herzegovina	GE	Georgia	MD	Republic of Moldova	TG	Togo
BB	Barbados	GH	Ghana	MG	Madagascar	TJ	Tajikistan
BE	Belgium	GN	Guinea	MK	The former Yugoslav Republic of Macedonia	TM	Turkmenistan
BF	Burkina Faso	GR	Greece	ML	Mali	TR	Turkey
BG	Bulgaria	HU	Hungary	MN	Mongolia	TT	Trinidad and Tobago
BJ	Benin	IE	Ireland	MR	Mauritania	UA	Ukraine
BR	Brazil	IL	Israel	MW	Malawi	UG	Uganda
BY	Belarus	IS	Iceland	MX	Mexico	US	United States of America
CA	Canada	IT	Italy	NE	Niger	UZ	Uzbekistan
CF	Central African Republic	JP	Japan	NL	Netherlands	VN	Viet Nam
CG	Congo	KE	Kenya	NO	Norway	YU	Yugoslavia
CH	Switzerland	KG	Kyrgyzstan	NZ	New Zealand	ZW	Zimbabwe
CI	Côte d'Ivoire	KP	Democratic People's Republic of Korea	PL	Poland		
CM	Cameroon	KR	Republic of Korea	PT	Portugal		
CN	China	KZ	Kazakstan	RO	Romania		
CU	Cuba	LC	Saint Lucia	RU	Russian Federation		
CZ	Czech Republic	LI	Liechtenstein	SD	Sudan		
DE	Germany	LK	Sri Lanka	SE	Sweden		
DK	Denmark	LR	Liberia	SG	Singapore		
EE	Estonia						

## TITLE

AN INTRAVAGINAL SUPPORT ABSORBENT MATERIAL URINARY  
INCONTINENCE DEVICE

## 5 BACKGROUND OF THE INVENTION

## 1. Field of the Invention

The present invention relates to an intravaginal device for treating urinary stress incontinence in females, which provides mechanical support for the bladder neck and absorbs incidental urinary spillage from the urethra,  
10 thereby preventing involuntary urination.

Female urinary incontinence is a widespread problem, both in postmenopausal women, and in women of child bearing age. Estimates indicate that approximately 30% of women over 40 years of age suffer from urinary incontinence.

15 To achieve urinary continence under normal conditions, the urinary bladder acts as a passive reservoir for fluid filtrate accumulating from the kidneys. Contraction waves leading to micturition originate in the proximal segment of the upper urinary tract and propagate in an anterograde direction toward the bladder. Central integration of neural control of the urinary bladder  
20 and urethra enable centrally-mediated inhibition of the motor neurons of the external urethral sphincter to permit micturition. The pressure in the urinary bladder must exceed that within the urethral lumen to permit fluid to flow from the urinary bladder along the urethra. This is achieved by a fall in urethral resistance, mediated in part by the *musculus dilator urethrae* system  
25 located in the neck of the bladder and in the wall of the urethra. The *musculus*

*dilator urethrae* system opposes the action of the *musculus sphincter trigonalis* and the *musculus sphincter urethra*, causing urethral dilation. Thus, the urinary bladder contracts via the detrusor smooth muscle and actively expels its contents into the urethra upon receiving contractile signals.

- 5 Contraction of the abdominal muscles and a lowering of the diaphragm elevate intra-abdominal pressure to help force urine from the bladder.

The passive elastic resistance exhibited by the urethral wall is thought to be the single most important factor responsible for controlling occlusion of the urinary bladder neck and proximal urethra in continent women. The  
10 external urethral sphincter is situated within the urethral wall, and is morphologically adapted to maintain tone over relatively long periods of time, thereby preventing a decrease in urethral resistance and the onset of fluid flow from the urinary bladder. The pelvic floor musculature provides additional occlusive force on the urethral wall, which helps to prevent urinary leakage,  
15 particularly during events which increase intra-abdominal pressure, such as coughing or sneezing. The voluntarily controlled periurethral muscles, which are skeletal muscles related to but structurally distinct from the urethral wall, aid in voluntary control of the external urethral sphincter.

Urinary incontinence is defined as any involuntary leakage of urine. In  
20 older women, instability of the detrusor muscle leads to urgency incontinence. This instability is often due to loss of normal neurologic inhibition of the urinary bladder musculature during filling of the bladder. Lack of neural control permits the detrusor muscle to contract prematurely when relatively little urine is present in the bladder. Consequently, the urge to void may be  
25 initiated when less than 150 ml of fluid is present.

Stress incontinence occurs upon leakage of urine during any event which raises intra-abdominal pressure, for example, coughing or sneezing. Overflow incontinence may arise in an obstructed or atonic urinary bladder. Diabetes may also result in an atonic bladder.

5           The decline in available estrogen during menopause or ovarian pathologies can contribute to stress incontinence in women. Loss of estrogenic activity leads to thinning of the vaginal wall and reduced vaginal secretions. Consequently, vaginal smooth muscle mass is decreased, thereby reducing mechanical support by the vaginal wall of the bladder neck and  
10 external urethral sphincter embedded therein. Stress incontinence is further exacerbated by loss of tone of the pelvic floor. This “falling” of the pelvic floor is associated with lack of support for the bladder neck and closure of the urethra, thereby inducing stress incontinence.

## 2. Description of the Related Art

15           The bladder neck is closely related to the anterior vaginal wall. Additionally, the anterior wall of the vagina is related to the urethra, which is embedded in the vaginal wall. Thus, supporting structures placed intravaginally assist in the proper anatomic placement of the external urethral sphincter in women lacking sufficient support to the bladder, thereby reducing  
20 urinary leakage.

In urethral hypermobility, intrinsic urethral pressures remain normal. Stress urinary incontinence due to urethral hypermobility occurs when a rise in intra-abdominal pressure increases intravesical pressure above ambient urethral pressure. The urethra cannot benefit from added abdominal pressure

due to poor positioning. Thus, the urethra actually moves out of the sphere of abdominal influence, descending lower into the vaginal cavity.

Known treatments of urinary incontinence usually involve mechanically improving support of the bladder neck, surgically repositioning  
5 fallen or torn tissue, hormone replacement therapy or intraurethral injections of collagen or teflon. Sanitary napkins are often used to capture leaking urine from the vulva, but are disadvantageous in that they are cumbersome and restrict the activities of the women using them. Surgery is often the treatment of choice for stress urinary incontinence, but many women are not good  
10 surgical candidates due to complicating factors. Similarly, many women are unable to take hormone replacement therapy due to unfavorable risk factors associated with estrogenic compounds, and cannot use estrogen therapy to enhance atrophic pelvic tissues.

Mechanical devices for supporting the bladder neck and external  
15 urethral sphincter are well-known in the art. U.S. Patent No. 5,618,256 to Reimer discloses an intravaginal device with flexible legs attached to a main body which cradles the urethra and bladder neck, compressing the structures through the vaginal wall. U.S. Patent No. 5,386,836 to Biswas discloses an intravaginal urinary incontinence device composed of a resilient circular base  
20 portion having integrally formed thereupon a bladder support portion extending away from the base portion, with the bladder support portion being provided with a cradle for supporting the neck of the bladder through the vaginal wall. The circular base portion of Biswas lies adjacent to the cervix upon insertion into the vagina. U.S. Patent No. 5,036,867 to Biswas discloses  
25 an intravaginal device having an arched central base portion connecting

forward and rearward portions. The forward portion has a projection means to lift the bladder base and bladder neck when the forward portion of the device is positioned adjacent to the anterior vaginal wall. The rearward portion lies adjacent to the posterior vaginal wall, holding the device in place. While these devices all provide means for supporting the bladder fundus and bladder neck, they do not completely prevent incontinence and provide no means to prevent soiling of clothing when urine flow cannot be completely inhibited.

U.S. Patent 5,609,559 to Weitzner discloses an intravaginal device including an anterior inflatable body having a hose attached thereto for the purpose of inflating the anterior body upon positioning the device within the vaginal cavity. A source of pressurized air is releasably attached to a distal end of the hose to facilitate inflation of the anterior body, disposing the body to apply pressure to the urethra through the vaginal wall. This device is cumbersome to use and does not provide a means for collecting urine that may leak around the inflated balloon.

#### BRIEF SUMMARY OF THE INVENTION

Accordingly, an object of the invention is to provide a device designed to prevent most urinary leakage and to collect incidental urine overflow to satisfy the needs of women suffering from stress incontinence.

Another object of the invention is to provide a device as described above that can be inserted and removed rapidly and easily.

A further object of the invention is to provide a device as described above that can be used without discomfort or tissue irritation.

Yet another object of the invention is to provide a device as described above that can be manufactured at low cost.

Preferred embodiments of the invention are constituted by an intravaginal absorbent urinary incontinence device for the prevention of involuntary urination comprising:

(a) an absorbent pessary member for absorbing urinary leakage, said absorbent pessary member having proximal and distal ends; and

(b) at least one flexible arcuate support member for supporting at least one of the bladder and bladder neck of a user.

Devices according to the invention can further include:

(c) at least one flexible arcuate wing member extending from the absorbent pessary member for positioning the device within the vaginal canal; and

(d) a removal string member attached to the absorbent pessary member.

The string member may be of the same material as, or a different material from, the absorbent pessary member.

Further embodiments of the invention are constituted by an intravaginal absorbent urinary incontinence device for the prevention of involuntary urination, comprising an absorbent pessary member for absorbing urinary leakage, absorbent pessary member having proximal and distal ends, a longitudinal axis that extends between ends and a plurality of protrusions that extend radially outwardly from axis, pessary member being insertable into a vaginal canal with an orientation in which one of protrusions support at least



one of the bladder neck and bladder in the vaginal canal, while at least one other protrusion helps to position said pessary member in the vaginal canal.

The invention further provides a process for preventing involuntary urination including the steps of:

- 5 (i) providing an intravaginal absorbent urinary incontinence device having one of the forms described above: and
- (ii) inserting and positioning the intravaginal absorbent urinary incontinence device within the vaginal cavity with the aid of an applicator.

10 As used herein, the distal end is that end which is directed toward the interior of the vaginal canal and the proximal end is directed toward the region outside of the user's body. The removal string member extends out of the proximal end of the absorbent pessary member.

15 BRIEF DESCRIPTION OF THE SEVERAL VIEWS OF THE DRAWING

FIGs. 1, 2 and 3 are side elevational, cross-sectional views of three basic embodiments of an intravaginal device according to the invention with one or two support members.

20 FIG. 4 is a side elevational view of a modified version of the embodiment of FIG 1.

FIG. 5 is a side elevational view of a further embodiment of the invention.

FIG. 6 is an end view of the device of FIG. 5, in the direction of arrow VI in FIG. 5, showing the device in its inserted state.

FIG. 7 is a plan view of a component of the device of FIGs. 5 and 6 prior to assembly of the device.

FIG. 8 is an end view of another embodiment of a device according to the present invention.

5 FIG. 9 is a side view, in the direction of arrow IX of FIG. 8, of one component of the device of FIG. 8.

FIG. 10 is a perspective view of an element of a modified version of the embodiment of FIGs. 8 and 9.

10 FIG. 11 is a side elevational view of an other embodiment of the invention.

FIG. 12 is a bottom plan view of the embodiment of FIG. 11.

FIG. 13 is a plan view of a component of the embodiment of FIGs. 11 and 12.

15 FIG. 14 is a top plan view of an intravaginal device according to the invention inserted into an applicator.

FIG. 15 is a side elevational view of an intravaginal device according to a further embodiment of the invention in a first state preparatory to insertion in a vaginal canal.

20 FIG. 16 is a side elevational view of the intravaginal device according to Figure 15 in a second state subsequent to insertion.

FIG. 17 is a side elevational view of an intravaginal device according to a still further embodiment of the invention in a first state preparatory to insertion in a vaginal canal.

25 FIG. 18 is a side elevational view of an intravaginal device according to FIG. 17 in a second state subsequent to insertion.

FIG. 19 is a side elevational view of an intravaginal device according to a still further embodiment of the invention in a first state preparatory to insertion in a vaginal canal.

FIG. 20 is a side elevational view of an intravaginal device according to FIG. 19 in a second state subsequent to insertion.

FIGs. 21A and 21B are plan views of expanded spring-out disks which can be employed in the devices of FIGs. 15 and 18.

FIG. 22 is a perspective view of a further embodiment of the invention.

10

#### DETAILED DESCRIPTION OF THE INVENTION

FIGs. 1, 2 and 3 show embodiments of the invention in which a pessary member 2 is provided with one or two flexible arcuate support members 4. In FIG. 1 there is only one flexible arcuate support member 4 positioned substantially near the proximal end of the absorbent pessary member for supporting the bladder neck. In FIG. 2, two flexible arcuate support members 4 are depicted in series disposed in the same plane of the absorbent pessary member 2 for supporting both the bladder neck and the bladder base. In FIG. 3, a single flexible arcuate support member 4 is dimensioned to extend along substantially the entire length of pessary member 2 and is also capable of supporting both the bladder neck and the bladder base.

20

Each embodiment is further provided with a removal string member 6 extending from the proximal end of pessary member 2.

The, or each, upper flexible arcuate support member 4 may be made of a plastic strip or other biocompatible material having a width, perpendicular to the plane of each figure, of about, for example, 1 inch. Support member 4 is

25

positioned on the absorbent pessary member 2 for applying pressure to the bladder neck, proximal urethra, and/or the bladder. Each support member 4 may be a curved rigid or semi-rigid part of a material that will apply the requisite pressure without causing discomfort or irritation. In all of the 5 embodiments described above, attachment of the, or each, flexible arcuate support member 4 to pessary member 2 may be achieved by adhesion with an inert, biocompatible polymer composition or by plastic strips wrapped around pessary member 2 and the ends of each support member 4.

FIG. 4 shows an alternative version of the embodiment of FIG. 1, 10 where support member 4 is replaced by an annular support member 14 that surrounds absorbent pessary member 2. Annular support member 14 may be made of the same material as each member 4 and is molded or shaped to have the bulging form shown in FIG. 4. To assemble pessary member 2 with annular support member 14, pessary member 2 may be radially compressed in 15 a suitable sleeve which has a diameter less than the inner diameter of annular support member 14 and then inserted into pessary member 2. Then the sleeve is removed while gripping removal string member 6 to hold pessary member 2 in place relative to annular support member 14. As the sleeve is removed, pessary member 2 expands radially so as to contact annular support member 20 14. The inner surface of support member 14 may be provided with a suitable adhesive for permanent attachment to pessary member 2. However, if the internal diameter of support member 14 is properly selected, it may grip pessary member 2 with sufficient force to eliminate the need for adhesive.

Alternatively, annular support member 14 may be slit longitudinally and spread apart for placement around pessary member 2 without the aid of a sleeve. In this case, the use of an adhesive would be advisable.

It will be apparent that alternative versions of the embodiments shown in FIGs. 2 and 3 can be constructed in a manner similar to that of FIG. 4.

Absorbent pessary member 2 may have the same form as a conventional tampon and in view of the form of support member 4 of FIGs. 1, 2 and 3, support member 14 of FIG. 4, and support members of alternative versions of the embodiments of FIGs. 2 and 3, devices according to these embodiments can be inserted in the same manner as conventional tampons without requiring an insertion device. In the case of the embodiments of FIGs. 1, 2 and 3, it is only necessary to assure that the device is oriented relative to its longitudinal axis to place support member 4 against the user's bladder or bladder neck.

FIGs. 5 and 6 show a further embodiment of an incontinence device according to the invention composed of absorbent pessary member 2 and a unit 20 that provides an upper vertical flexible arcuate support member 24 for supporting the bladder and/or bladder neck, and two lateral flexible arcuate wing members 26 for positioning and securely holding the device against the vaginal wall. Unit 20 further includes two annular bands 28 and 30 which encircle pessary member 2 in order to hold unit 20 in a desired position on pessary member 2. Adhesive may be provided between bands 28 and 30 and pessary member 2, although this will not be necessary if bands 28 and 30 are given an appropriate diameter. Pessary member 2 may be inserted into unit 20 in the manner described above with reference to Figure 4.

Unit 20 may be a molded, semirigid plastic part which is suitably processed to impart the desired curvatures to members 24 and 26.

FIG. 6 shows the device of FIG. 5 in an inserted state. The vaginal wall 32 will bear against portions of pessary member 2 to allow the latter to absorb liquid present on wall 32, as well as liquid that may accumulate in the vaginal opening.

FIG. 7 shows an embodiment of unit 20 that may be produced by cutting a flat sheet of semirigid plastic to have the illustrated outline, followed by postforming to give support member 24 and arcuate wing members 26 the desired curvatures. This postforming will reduce the distance between bands 28 and 30, relative to that illustrated in FIG. 7, and allow the free end of support member 24 to be attached to band 30. This attachment may be achieved by application of an adhesive, or by thermowelding, etc. Then, unit 20 may be wrapped around pessary member 2 and the free ends of bands 28 and 30 may be secured to one another, again by application of an adhesive, or by thermowelding, etc.

FIGs. 8 and 9 are, respectively, an end view of another embodiment of a device according to the invention and a side view of one component 32 of that device. According to one form of construction, component 32 is composed of two separately molded and formed semirigid plastic parts. One of these parts is formed to provide an arcuate support member 34. The other one of these parts is a one-piece part which includes two arcuate wing members 36, two annular bands 38 at opposite ends of the component, and an arcuate central element 40 which extends around approximately two-thirds of the circumference of component 32, and of pessary member 2 (not shown in

FIG. 9). Arcuate wing members 36 are joined to bands 38 and central element 40 along crease lines, shown in broken lines in FIG. 9, where a permanent bend is imparted by a suitable forming process.

The two parts of component 32 are joined together by bonding the  
5 ends of the part which provides support member 34 to one band 38 and  
element 40 by means of an adhesive, or by thermowelding, etc. Preferably,  
component 32 has nearly the same length as pessary member 2, similar to  
member 4 of FIG. 3.

While, as mentioned above, component 32 is made of two semirigid  
10 parts, it is also possible to make the part constituting elements 36, 38 and 40 of  
a soft, flexible plastic and to give wing members 36 the necessary shape and  
stiffness by employing a resilient plastic or metal armature 41, as shown in  
FIG. 10. Armature 41 has two opposed arcuate segments 42 that will be  
bonded to the arcuate edges of wing members 36 and two opposed circular  
15 arcuate segments 43 that extend between segments 42 and that will be bonded  
to portions of bands 38 that extend between wing members 36. These bonds  
can be formed in any suitable manner, as described above. Armature 41 thus  
holds the edges of wing members 36 in the desired positions and gives them  
the desired resilient stiffness.

20 A further embodiment of the invention is shown in FIGs. 11 and 12  
which are, respectively, a side elevational view and a bottom plan view. In  
this embodiment, pessary member 2 is provided with one support member 44  
and four wing members 46. Members 46 extend away from pessary member 2  
in the direction toward the distal end of pessary member 2. Members 44 and  
25 46 are supported by, and are integral with, two annular bands 48 and 50. As in

the case of embodiments previously described, members 44 and 46 and bands 48 and 50 can be made of a semirigid plastic. According to one example, a molded plastic tube can be cut to create members 44 and 46 and bands 48 and 50 and the resulting structure can be shaped, with the aid of heat, to give member 44 the desired arcuate form and to cause members 46 to extend outwardly at an angle relative to bands 48 and 50.

Pessary member 2 may be inserted into the space enclosed by bands 48 and 50 in the manner described above with reference to the embodiment of FIG. 4.

Alternatively, as shown in FIG. 13, members 44 and 46 and bands 48 and 50 can initially be formed by suitably cutting a flat plastic sheet and performing a forming operation to give members 44 and 46 the desired shapes. Then bands 48 and 50 can be wrapped around pessary member 2 and the free ends of bands 48 and 50 can be bonded together by any suitable means, such as described earlier herein. In the case of the embodiments described above with reference to FIGs. 11-13, bands 48 and 50 can optionally be attached to pessary member 2 by a suitable adhesive.

The component providing members 44 and 46 and bands 48 may be made of a flexible plastic, such as an elastomer, permitting wing members 46 to be flattened against absorbent pessary member 2 by an applicator 56 as will be described below with reference to FIG. 14. Preferably, this component is made of polyvinyl chloride, polyethylene, or silicone.

The outward curvature of members 44 and 46 can also be produced by bulging of pessary member 2 when bands 48 are wrapped tightly around pessary member 2.



Because of the configuration of wing members 46 in the embodiments having the form shown in FIGs. 11-13, insertion may be effected with greater comfort if aided by an applicator of a type similar to that which is employed for tampons. For example, as shown in FIG. 14, the device according to the invention may be inserted with the aid of an applicator 56 composed of an open-ended outer tube 56' housing the incontinence device according to the invention and an open-ended inner tube 56" slidable in tube 56'. Outer tube 56 is slightly shorter than inner tube 56". An indicium in the form of an arrow, as shown, may be placed on inner tube 56" to identify the angular orientation that the incontinence device must have in order for support member 44 to be properly positioned against the bladder or the bladder neck. Proper orientation is achieved when the arrow is facing directly upwardly.

Initially, the distal end of inner tube 56" is inserted into the proximal end of outer tube 56', and the distal end of inner tube 56" may then be in contact with the proximal end of pessary member 2, all as shown in FIG. 14. The distal end of pessary member 2 initially protrudes slightly beyond the distal end of outer tube 56' and string member 6 extends through inner tube 56", also as shown in FIG. 14.

In this state, the distal ends of pessary member 2 and outer tube 56' are inserted into the vagina to a point at which a portion of outer tube 56' projects out of the vagina. Then the user pushes inner tube 56" into outer tube 56' while holding outer tube 56' in place. As inner tube 56" penetrates into outer tube 56', pessary member 2 is pushed by inner tube 56" out of outer tube 56' until being completely expelled from outer tube 56' and properly positioned in

the vaginal passage. Finally, tubes 56' and 56" are withdrawn together from the vagina.

As flexible arcuate wing members 46 exit applicator 56, they expand to prevent the device from moving, permitting the vertical flexible arcuate support member 44 to support, in this embodiment, the bladder neck.

In each of the above-described embodiments, the entire urinary incontinence device, or a portion thereof, such as the insertion end, may be coated with a lubricant prior to insertion, either during manufacture or by the user, to assist with the insertion process.

Absorbent pessary member 2 as shown has an elongated circular cylinder shape, but could be configured in any other shape that allows it to be inserted into, and comfortably worn in, the vagina, such as an elongated hexagonal or octagonal cylinder, to cite two nonlimiting examples. Member 2 may be made of any material or materials that are biocompatible, or nontoxic, and that are capable of maintaining the shape of member 2 when inserted in the vagina. Member 2 may be composed entirely or partially of any absorbent material capable of absorbing at least a measurable quantity of urine. The descriptions herein of suitable absorbent materials are provided solely by way of nonlimiting example. Thus, member 2 may comprise a mass of compressed, biodegradable fibers, which may be natural or synthetic. Suitable materials include a combination of cotton batting and cotton gauze. Preferably, member 2 comprises a compressed cotton material suitable for absorbing several times its dry weight in liquid. Materials such as carboxymethylcellulose, polyacrylate rayon and polyester foams should be avoided due to their substantially high rate of absorbency, which may promote

*Staphylococcus aureus* infection. In the alternative, member 2 may comprise a plastic core around which the compressed absorbent material is layered.

Member 2 serves to absorb urine which may leak from the urethra, despite the mechanical support afforded by the intravaginal urinary incontinence device of the invention. Pessary members of commonly used incontinence devices do not appreciably absorb urinary spillage. Member 2, or its outer surface, may be made of a material having coefficient of friction that helps to prevent the inserted member from being dislodged from its proper position.

The absorbent pessary material may be impregnated with a deodorant, if desired. Deodorants safe for contact with vaginal membranes are well known in the art of feminine hygiene products.

Absorbent pessary member 2 may also be impregnated with a therapeutic agent for intravaginal delivery. The therapeutic agent may be an antimicrobial, appropriate for controlling local vaginal infections due to fungi, viruses, bacteria and the like. Likewise, the therapeutic agent may comprise an anti-inflammatory agent, such as a nonsteroidal anti-inflammatory compound to reduce localized vaginal irritation and swelling of the vaginal membranes. Antineoplastic compounds may be delivered intravaginally to vaginal tissues or the cervix via this method. Furthermore, hormones, particularly estrogen or derivatives thereof, may be administered intravaginally by impregnating the absorbent pessary member with these compounds. Release may be controlled by microencapsulation of the therapeutic agents prior to impregnation into the pessary member. The warm, moist environment of the vaginal canal would serve as an activation mechanism to chaperone release of the therapeutics from the impregnated pessary member. Dosages may be titrated by adjusting the

length of time the absorbent urinary incontinence device is left within the vagina. The use of an intravaginal absorbent urinary incontinence device according to the invention for delivery of therapeutic agents would follow guidelines for known intravaginal drug delivery systems.

5           Epithelial absorption of compounds released from the absorbent pessary member may permit distribution of the agents beyond the vaginal region. For example, combining the mechanical support of the absorbent urinary incontinence device of the invention with delivery of estrogen to pelvic musculature may afford a synergistic approach to relieving urinary  
10 incontinence in women lacking estrogen. Estrogen absorbed across the vaginal wall may serve to activate estrogen receptors responsible for improving the tone of the musculature of the pelvic floor. A daily intravaginal dosage of 2 to 20  $\mu\text{g}$  of estrogen or an estrogenic compound could be facilitated by impregnation of the hormone in the absorbent pessary member of  
15 the urinary incontinence device of the invention. Absorbent pessary member 2 may also be impregnated with any standard transvaginal cream preparation, such as an estrogenic cream, to obtain the same desired drug delivery effect. One such preparation may be a 1% estrogen cream marketed under the tradename Premarin.

20           In general, at least one flexible arcuate wing member is provided for positioning the incontinence device in the vagina in a manner to maintain the support member firmly against at least one of the bladder neck and bladder. The flexible arcuate wing members may be curved differently from the forms illustrated herein, as long as the shape permits the arcuate wing members to  
25 securely retain the device in the vagina.

The flexible nature of the arcuate wing members of the various embodiments of the invention permits the wings to continuously adjust to the dimensions of the vagina. Flexible wing members may be integrally molded with a non-absorbent core piece of the absorbent pessary member 2, or, as  
5 illustrated in the above-described figures, may be formed separately and attached to the pessary in such a fashion as to permit movement for flattening and expansion of the arcuate wing members. The flexible wing members may be covered with the absorbent material of the pessary for cushioning purposes. Cushioning may be effected by making the wing members of a soft polymer, in  
10 lieu of an absorbent cover.

As shown in various figures, the flexible arcuate wing members may be positioned in several configurations around pessary member 2. In FIGs. 5-7 the flexible arcuate wing members extend radially from adjacent to the proximal end of the absorbent pessary member 2. In FIGs. 8 and 9 the flexible  
15 wing members extend over substantially the full length of pessary member 2. In FIGs. 11-13, the flexible wing members extend over a substantial portion of the length of pessary member 2. Full extension along substantially the full length of pessary member 2 imparts optimal stability to the device upon insertion into the vagina. In general, the flexible wing members should  
20 prevent rolling or displacement of the device.

Preferably, in embodiments of the type shown in FIGs. 11-13, two or four flexible arcuate wing members are disposed to extend from the absorbent pessary member, forming an angle between about 30° to about 45° relative to the longitudinal axis of pessary member 2. Removal string member 6 is  
25 disposed at the proximal end of member 2 for withdrawal of the device from

the vaginal canal. Removal string member 6 may be made of natural or synthetic fibers, such as cotton, silk, rayon or nylon, woven in a particular fashion so as to impair microbial proliferation or retrograde microbial migration along the length of the string. Such designs are well known in the field of feminine hygiene products.

The flexible arcuate wing members of FIGs. 11-13 are oriented so that during the process of removing the intravaginal urinary incontinence device from the vagina, by pulling on removal string member 6, they tend to flatten against member 2. Pressure from the vaginal walls aids in compressing these arcuate wing members during removal. In the other illustrated embodiments, the arcuate form of the wing members assures easy removal of the device.

The intravaginal urinary incontinence device of the invention may be lubricated prior to insertion, thereby enhancing the comfort of the removal process. Water soluble lubricants or petroleum-based jellies may be used.

Individual intravaginal urinary incontinence devices may be worn internally for about 6 to about 12 hours, and should be removed and replaced on a daily basis.

Several further embodiments of an intravaginal absorbent urinary incontinence device according to the invention are illustrated in FIGs. 15-21B.

The embodiment shown in FIGs. 15 and 16 is composed of an absorbent pessary member 110 made of any one of the absorbent materials described earlier herein and provided internally with two hollow tubular sleeves 112 made of a relatively rigid material. Each sleeve 112 houses a respective spring-out disk 114 in a laterally compressed, or folded, state. Spring-out disks may be solid disk 114', as shown in FIG. 21A, or segmented

disks 114", as shown in FIG. 21B. Each disk 114 is made of a suitable resiliently deformable material, typically metal or semirigid plastic, and has a center point which is directed toward the proximal end of member 110 and is secured to a removal string member 104. String member 104 is movable  
5 relative to member 110 as long as disks 114 are confined by sleeves 112.

After member 110 has been inserted and properly positioned within a vaginal canal, string member 104 is pulled, while suitably restraining member 110 so that member 110 remains in position, in order to extract disks 114 from their respective sleeves 112. When disks 114 are fully extracted from sleeves  
10 112, disks 114 spring open into the positions shown in FIG. 16, with the result that portions of member 110 are forced radially outwardly in order to produce annular bulging portions 116. These bulging portions, since they extend continuously around the circumference of member 110, perform the functions of both the support members and the wing members of the embodiments  
15 described earlier herein. In the embodiment shown in FIGs. 15 and 16, two annular bulging portions 116 are formed and each of these presses against a respective one of the bladder neck and the bladder within the vaginal canal.

When disks 114 are in their open position, they lock string member 104 against further movement relative to member 110. Therefore, when  
20 member 110 is to be removed, this can be achieved by pulling on string member 104.

In the embodiment shown in FIGs. 17 and 18, an absorbent pessary member 120, made of any one of the materials described earlier herein, is formed to have a hollow core 122 and a hollow tubular sleeve 124 made of a  
25 rigid material and located at the proximal end of core 122. Sleeve 124

contains a spring-out disk 126 that is smaller than each of disks 114 of FIGs. 15 and 16 and that is initially resiliently deformed in sleeve 124 as shown in FIG. 17. In this embodiment, removal string member 104 is fastened at its distal end to the material of member 120.

5           String member 104 passes through core 122 and is secured to disk 126. In the region between disk 126 and the proximal end of member 120, string member 104 is free to move relative to member 120.

          After member 120 has been inserted into the vaginal canal, the user can pull on string member 104 while suitably restraining member 120 to prevent  
10 movement of the proximal end of member 120, so that the distal end of member 120 is pulled toward the proximal end by its attachment to string member 104 and disk 126 is pulled out of sleeve 124. When disk 126 leaves the confines of sleeve 124, disk 126 springs outwardly to prevent collapse of the structure. As a result of the axial shortening of member 120, a portion of  
15 member 120 is deformed radially outwardly to create an annular bulging portion 128 that protrudes radially outwardly at a location to bear against either the bladder or the bladder neck within the vaginal canal. Here again, bulging portion 128 performs the functions of both the support member and the wing members of the embodiments described earlier herein. Member 120  
20 is provided with tapered, angular grooves 132 that extend from the wall of hollow core 122 such that the bulge occurs in a predetermined, limited area. When string 104 is released, disk 126 will move back into contact with the proximal end of sleeve 124, as shown in FIG. 18, in response to longitudinal elongation of member 120 under the effect of its inherent resiliency.



In yet another embodiment shown in FIGs. 19 and 20, absorbent pessary member 140 may contain an initially compressed ball 142 made from, for example, silicone, in place of spring-out disks. In the case of this embodiment, member 140 will be inserted with the aid of an applicator  
5 composed of an outer tube 144 and an inner tube 145. Outer tube 144 is slightly shorter than inner tube 145.

Prior to being packaged for sale, member 140 will be inserted into tube 144 by any suitable device and one end of tube 145 will be inserted into tube 144. Tube 145 has a diameter which causes it to abut against the proximal end  
10 of member 140.

After the user removes the assembly of member 140 and tubes 144 and 145 from its package, tube 144 is inserted into the vagina and the applicator will be operated in the same manner as the applicator of FIG. 14. After member 140 has emerged fully from tube 144, tubes 144 and 145 can be  
15 discarded. During insertion of member 140, compressed ball 142 leaves the confines of tube 144, and expands radially outwardly. As a result, a portion of member 140 is deformed radially outwardly to create an annular bulging portion 146 that protrudes radially outwardly at a location to bear against either the bladder or the bladder neck within the vaginal canal.

20 A further embodiment of the invention is shown in Figure 22. This embodiment is constituted by a one-piece absorbent body 150 having three protrusions, or ridges, 152. Protrusions 152 extend radially outwardly from the center of body 150 and also extend uniformly along the length of body 150. Depending on the orientation with which body 150 is inserted into a vagina,  
25 one protrusion 152 will serve as a support member against the bladder, or

bladder neck, while the other two protrusions <sup>24</sup> 152 will serve as wing members that maintain body 150 in the desired position within the vaginal canal.

Body 150 may be inserted with the aid of an applicator, in the same manner as described above with reference to FIG. 19.

5           This device is completed, as in the case of the devices previously described, by a pull string 154.

The absorbent member of all of the devices disclosed herein may be made of the materials described earlier herein and may be impregnated with the various agents that were also described earlier herein.

10           While the invention has been described in detail and with reference to specific embodiments thereof, it will be apparent to those of ordinary skill in the art that various changes and modifications can be made therein without departing from the spirit and scope thereof.

## CLAIMS

What is claimed is:

1. An intravaginal absorbent urinary incontinence device for the prevention of involuntary urination comprising:

(a) an absorbent pessary member for absorbing urinary leakage, said absorbent pessary member having proximal and distal ends; and

5 (b) at least one flexible arcuate support member for supporting at least one of the bladder neck and bladder in the vaginal canal.

2. The intravaginal absorbent urinary incontinence device according to claim 1, further comprising:

(c) at least one flexible arcuate wing member extending from said absorbent pessary member for positioning said device within a vaginal  
5 canal; and

(d) a removal string member attached to said absorbent pessary member and extending from said proximal end.

3. The intravaginal absorbent urinary incontinence device according to claim 2, wherein said at least one flexible arcuate wing member is secured to said absorbent pessary member substantially adjacent to said proximal end.

4. The intravaginal absorbent urinary incontinence device according to claim 2, wherein said at least one flexible arcuate wing member comprises two wing members each extending at an angle of about 30° to about 45° from said absorbent pessary member.

5. The intravaginal absorbent urinary incontinence device according to claim 2, wherein said at least one flexible arcuate support member comprises at least two support members spaced from one another in series in a direction between said proximal end and said distal end in a common plane on said absorbent pessary member.

6. The intravaginal absorbent urinary incontinence device according to claim 5, wherein said at least one flexible arcuate wing member comprises a silicone sheet disposed across a peripheral metal wire supporting means.

7. The intravaginal absorbent urinary incontinence device according to claim 2, wherein said at least one flexible arcuate wing member is made of a material selected from the group consisting of silicone, polyvinyl chloride and polyethylene.

8. The intravaginal absorbent urinary incontinence device according to claim 2, wherein said support member and said flexible arcuate wing member are constituted by components of a plastic unit.

9. The intravaginal absorbent urinary incontinence device according to claim 8, wherein said plastic unit is a one-piece unit.

10. The intravaginal absorbent urinary incontinence device according to claim 2, wherein said at least one flexible arcuate wing member comprises a plurality of wing members that are angularly offset from one another around said absorbent pessary member.

11. The intravaginal absorbent urinary incontinence device according to claim 2, wherein said at least one flexible arcuate wing member extends along substantially the entirety of said absorbent pessary member between said proximal and distal ends.

12. The intravaginal absorbent urinary incontinence device according to claim 2, wherein said incontinence device is housed, prior to insertion, within a cylindrical applicator tube having a piston-like element, the applicator tube compressing said at least one flexible arcuate wing member against said absorbent pessary member, such that said at least one flexible arcuate wing member is released from the compressed state upon depression of said piston-like element and removal from the applicator tube during vaginal insertion of said incontinence device.

13. The intravaginal absorbent urinary incontinence device according to claim 1, wherein said absorbent pessary member comprises a cylindrical mass of compressed biodegradable material.

14. The intravaginal absorbent urinary incontinence device according to claim 1, wherein said device is coated with a lubricant.
15. The intravaginal absorbent urinary incontinence device according to claim 1, wherein said support member is constituted by an arcuate, semirigid body that is adhered to said absorbent pessary member.
16. The intravaginal absorbent urinary incontinence device according to claim 1, wherein said support member is constituted by an annular body which surrounds said absorbent pessary member.
17. The intravaginal absorbent urinary incontinence device according to claim 16, wherein said support member is dimensioned to radially compress said absorbent pessary member.
18. The intravaginal absorbent urinary incontinence device according to claim 1, wherein said support member extends along substantially the entirety of said absorbent pessary member between said proximal and distal ends.
19. The intravaginal absorbent urinary incontinence device according to claim 1, further comprising a therapeutic agent for intravaginal delivery, said agent containing estrogen and being impregnated in said absorbent pessary member.

20. An intravaginal absorbent urinary incontinence device for the prevention of involuntary urination, comprising:
- (a) a deformable absorbent pessary member for absorbing urinary leakage, said absorbent pessary member having proximal and distal ends and an internal cavity; and
- (b) deforming means housed in said cavity and operable for radially expanding a portion of said pessary member at a location between said proximal and distal ends at which said portion will, when said pessary member is inserted in a vaginal canal and said portion is expanded, support at least one of the bladder neck and bladder in the vaginal canal.

21. The intravaginal absorbent urinary incontinence device according to claim 20 wherein said deforming means comprise a resiliently deformable body.

22. The intravaginal absorbent urinary incontinence device according to claim 21 wherein said body is spherical.

23. The intravaginal absorbent urinary incontinence device according to claim 21 wherein said resiliently deformable body has a normal, radially expanded state in which said deforming member causes radial expansion of said pessary member portion, and said resiliently deformable body is radially  
5 deformable into a radially compressed state;

said deforming means further comprise a retaining element for retaining said resiliently deformable body in the radially compressed state;

and said resiliently deformable body is movable out of said retaining element to assume the normal, radially expanded state.

24. The intravaginal absorbent urinary incontinence device according to claim 23 wherein said radially deformable body is coupled to said pessary member for axially compressing said pessary member in order to radially expand said portion of said pessary member when said resiliently  
5 deformable member is moved out of said retaining element.

25. The intravaginal absorbent urinary incontinence device according to claim 24 wherein said radially deformable body is a disc spring.

26. The intravaginal absorbent urinary incontinence device according to claim 23 wherein said deforming means is a disc spring.



27. The intravaginal absorbent urinary incontinence device according to claim 23 further comprising a pull string coupled to said resiliently deformable body for moving said resiliently deformable body out of said retaining element in response to a pulling force exerted on said string.

28. An intravaginal absorbent urinary incontinence device for the prevention of involuntary urination, comprising an absorbent pessary member for absorbing urinary leakage, said absorbent pessary member having proximal and distal ends, a longitudinal axis that extends between said ends and a  
5 plurality of protrusions that extend radially outwardly from said axis, said pessary member being insertable into a vaginal canal with an orientation in which one of said protrusions support at least one of the bladder neck and bladder in the vaginal canal, while at least one other protrusion helps to position said pessary member in the vaginal canal.

29. A process for preventing involuntary urination comprising the steps of:

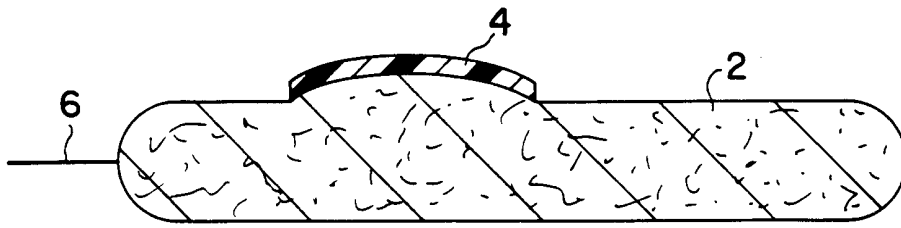
- (i) providing the device defined in claim 1;
- (ii) inserting and positioning said device within the vaginal  
5 cavity with the aid of an applicator tube.

30. The process of claim 29, wherein the device further comprises:
- (b) at least one flexible arcuate wing member extending from the absorbent pessary member for positioning the device within the vaginal canal; and
  - 5 (d) a removal string member attached to the absorbent pessary member and extending from said proximal end.
31. A process for preventing involuntary urination comprising the steps of:
- (i) providing the device defined in claim 20;
  - (ii) inserting and positioning said device within the vaginal
  - 5 cavity; and
  - (iii). operating said deforming means to radially expand said portion of said pessary member.

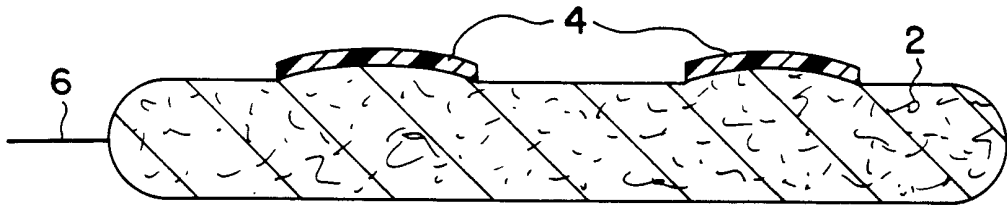
32. A process for preventing involuntary urination comprising the steps of:
- (i) providing the device defined in claim 28;
  - (ii) inserting and positioning said device within the vaginal
- 5 cavity with said one of said protrusions oriented to support at least one of the bladder neck and bladder.

33. The process of claim 32 wherein said step of inserting and positioning is performed with the aid of an applicator tube.

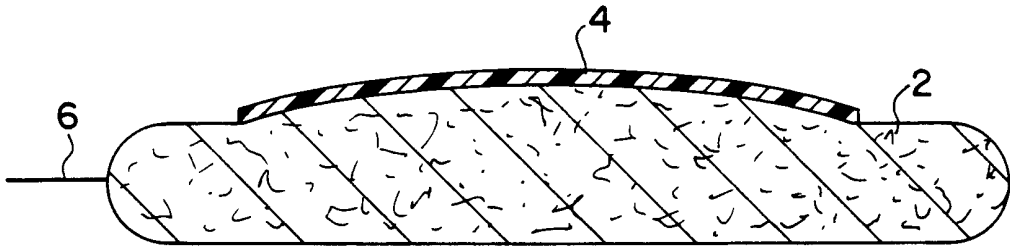
1/8



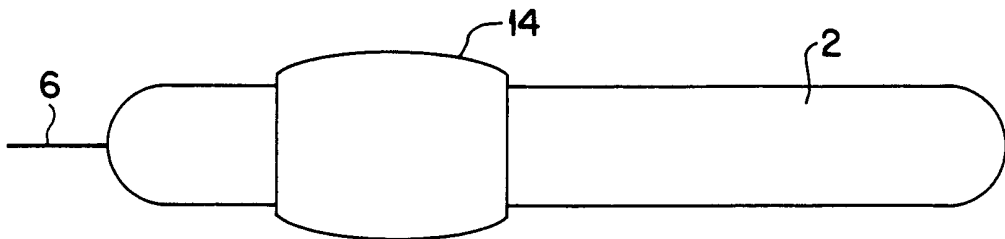
**FIG. 1**



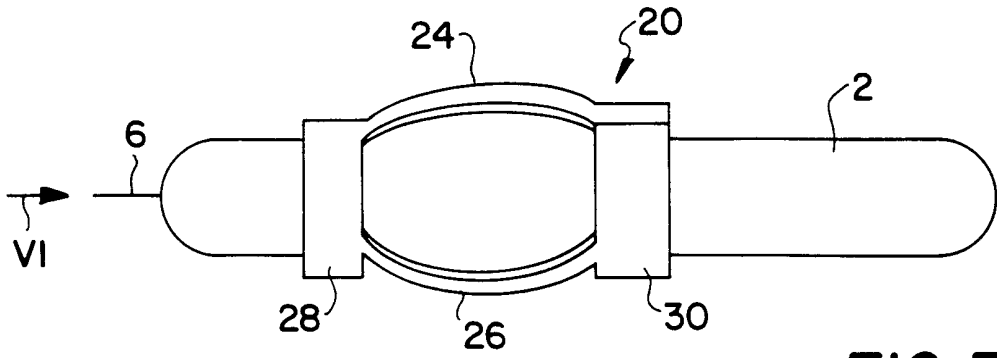
**FIG. 2**



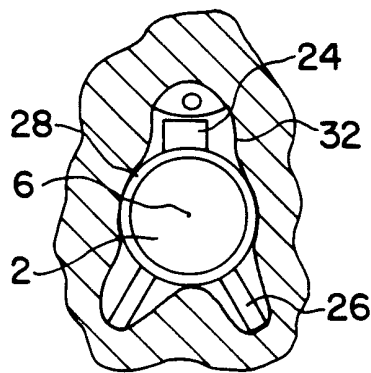
**FIG. 3**



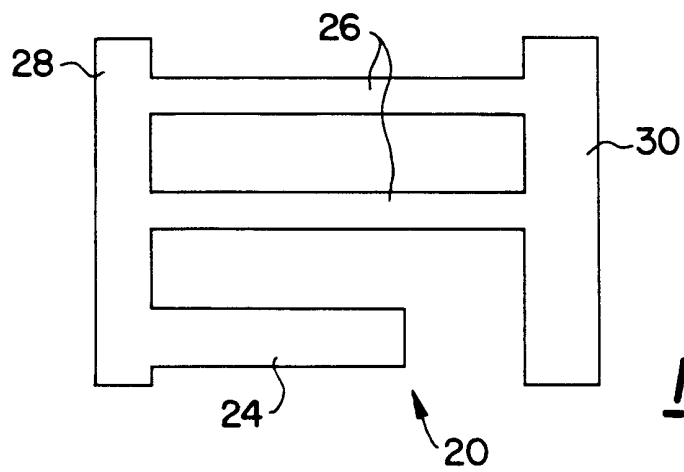
**FIG. 4**



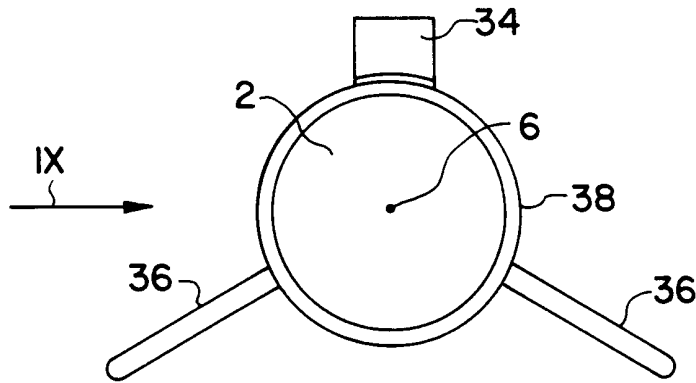
**FIG. 5**



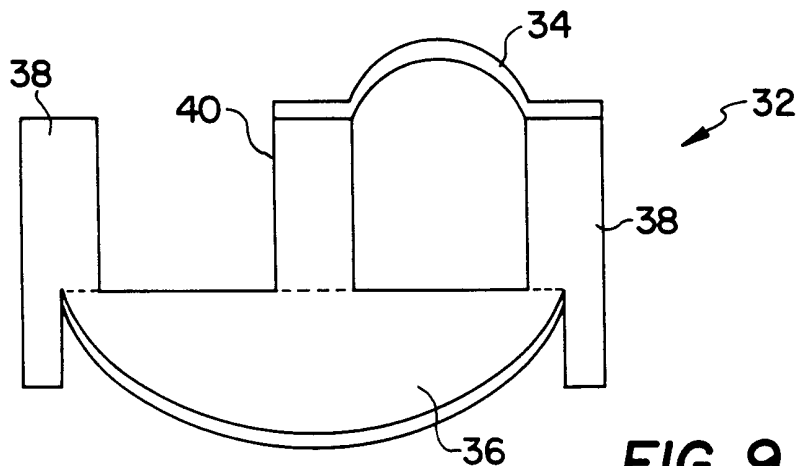
**FIG. 6**



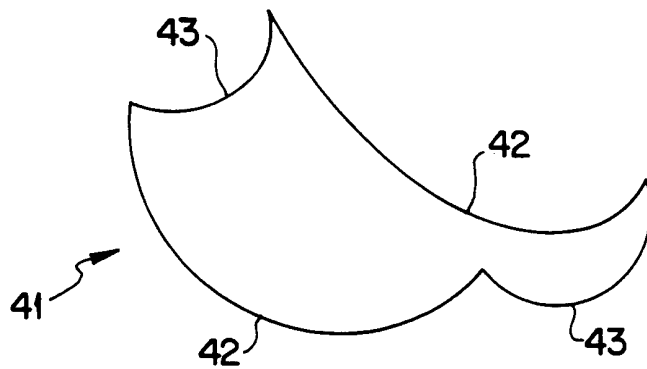
**FIG. 7**



**FIG. 8**

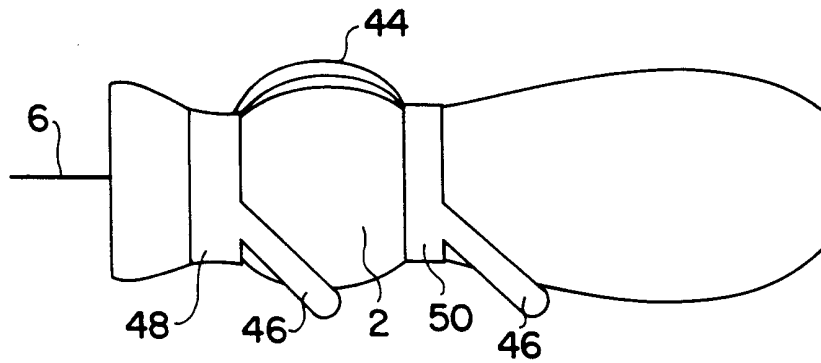


**FIG. 9**

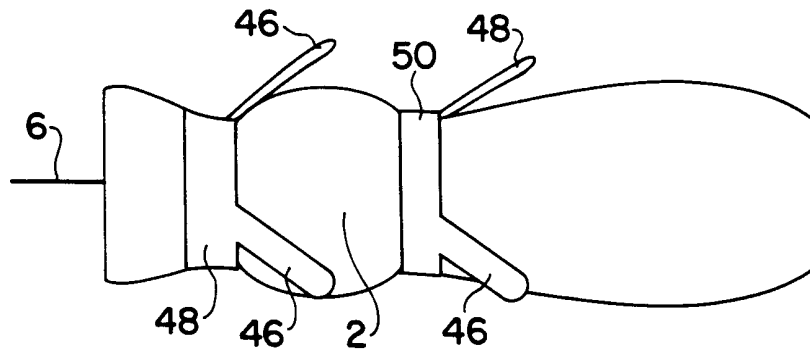


**FIG. 10**

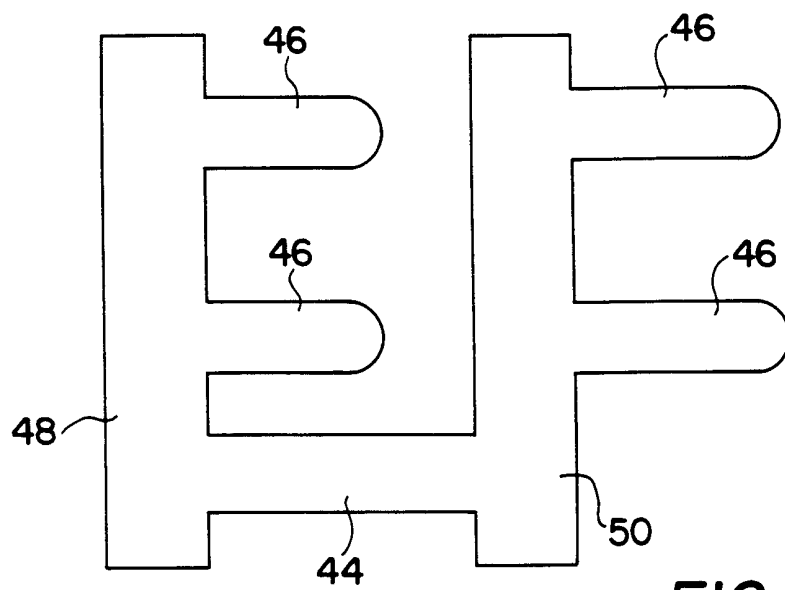
4/8



**FIG. 11**

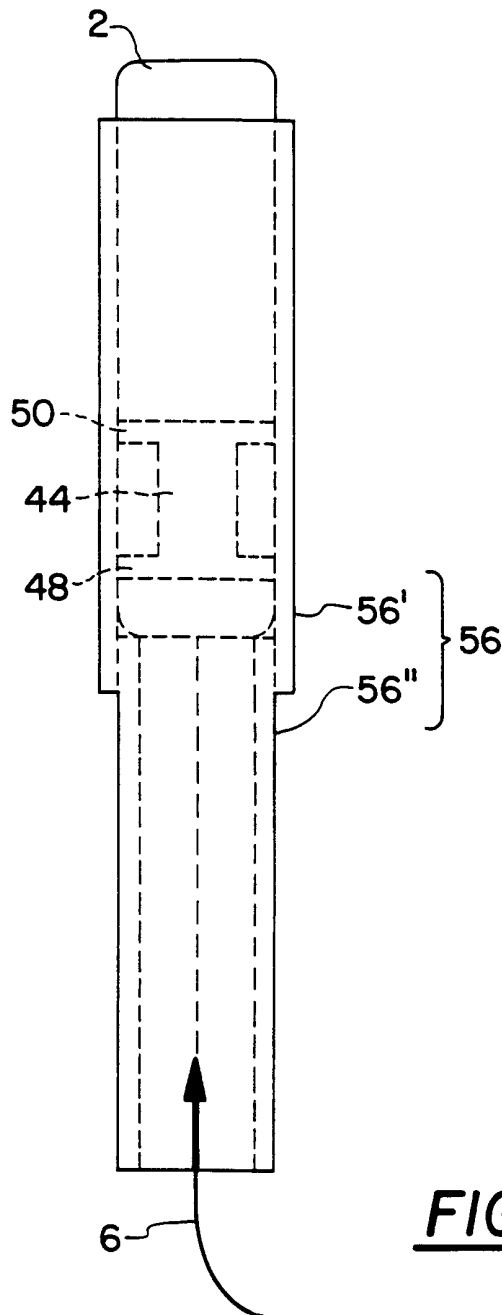


**FIG. 12**



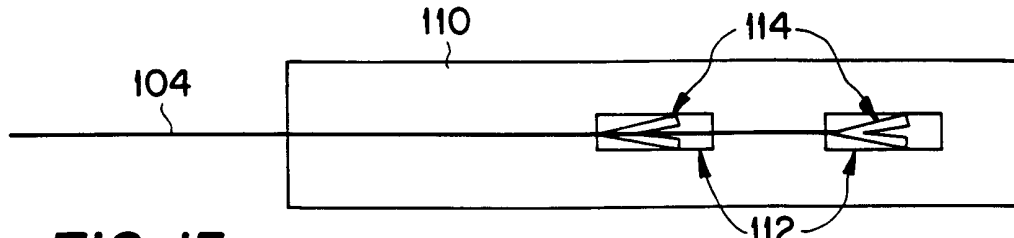
**FIG. 13**

5/8

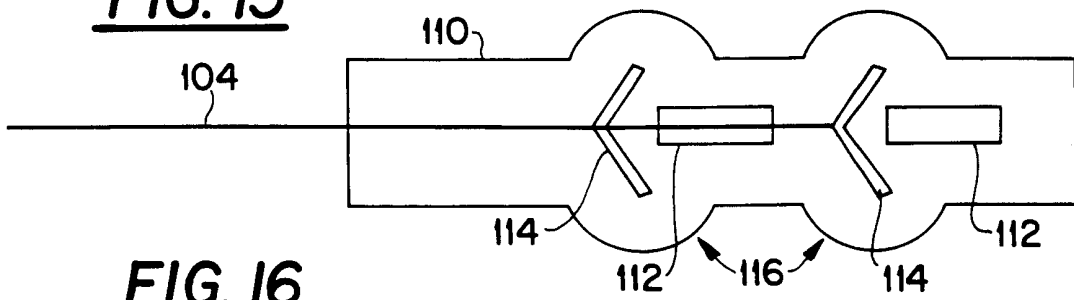


**FIG. 14**

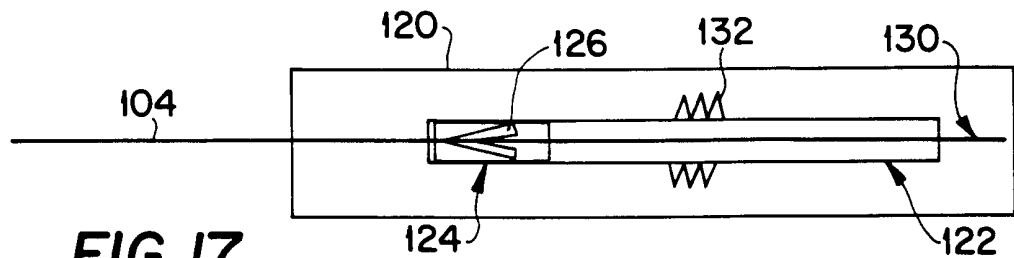




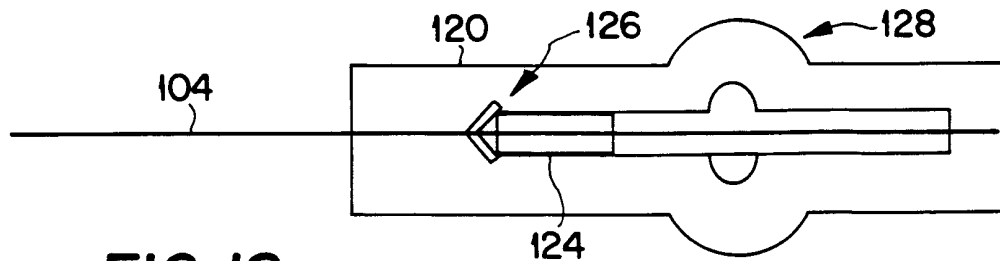
**FIG. 15**



**FIG. 16**



**FIG. 17**



**FIG. 18**

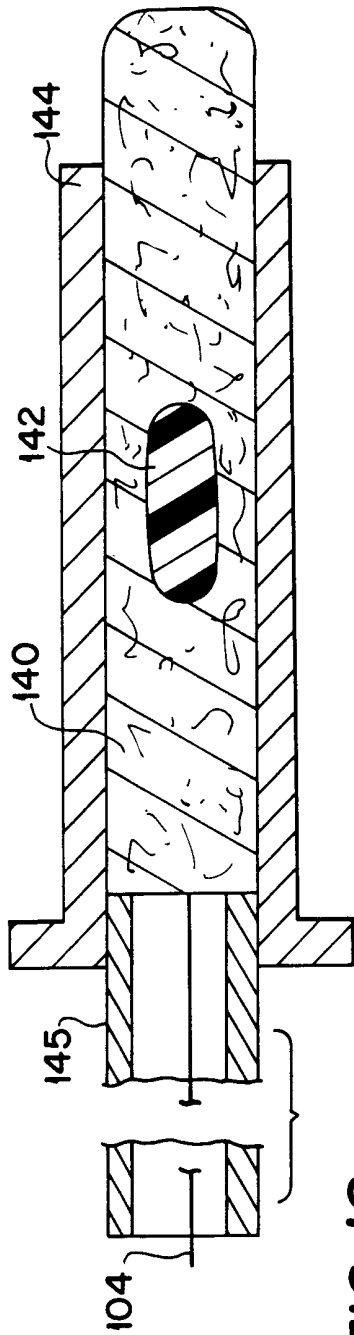


FIG. 19

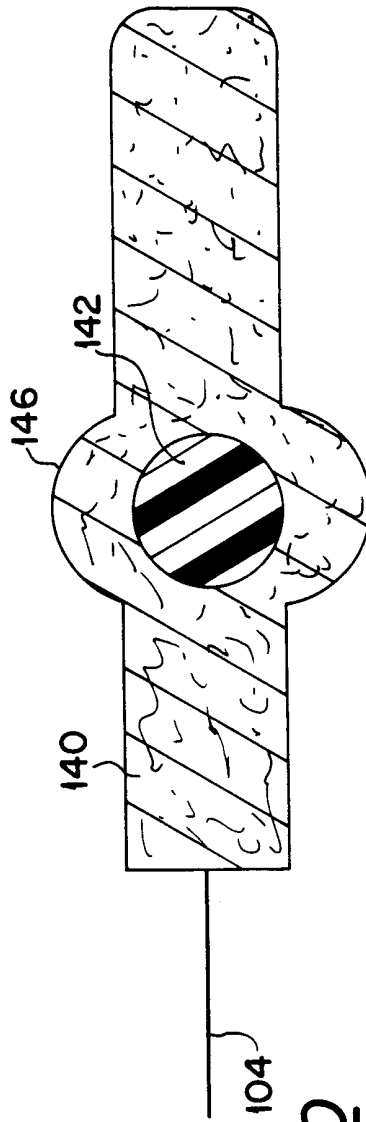
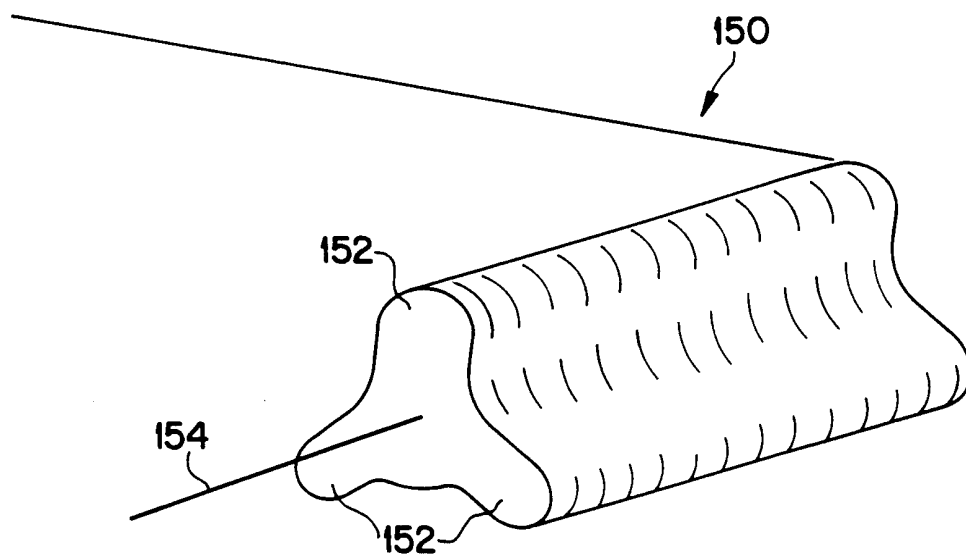


FIG. 20



FIG. 21A

FIG. 21B



**FIG. 22**

# INTERNATIONAL SEARCH REPORT

Inter. Application No <b>PCT/US 00/12515</b>
---

**A. CLASSIFICATION OF SUBJECT MATTER**  
**IPC 7 A61F2/00**

According to International Patent Classification (IPC) or to both national classification and IPC

**B. FIELDS SEARCHED**

Minimum documentation searched (classification system followed by classification symbols)  
**IPC 7 A61F**

Documentation searched other than minimum documentation to the extent that such documents are included in the fields searched

Electronic data base consulted during the international search (name of data base and, where practical, search terms used)  
**EPO-Internal**

**C. DOCUMENTS CONSIDERED TO BE RELEVANT**

Category °	Citation of document, with indication, where appropriate, of the relevant passages	Relevant to claim No.
A	WO 88 10106 A (PROSTHEX LTD) 29 December 1988 (1988-12-29) the whole document ---	1-33
A	US 5 483 976 A (MCLAUGHLIN PAUL D ET AL) 16 January 1996 (1996-01-16) the whole document ---	1-33
A	US 5 336 208 A (ROSENBLUTH ROBERT F ET AL) 9 August 1994 (1994-08-09) the whole document ---	1-33
A	US 5 659 934 A (JESSUP JAMES LYLE ET AL) 26 August 1997 (1997-08-26) the whole document ---	1-33
	-/--	

Further documents are listed in the continuation of box C.       Patent family members are listed in annex.

° Special categories of cited documents :

*A* document defining the general state of the art which is not considered to be of particular relevance *E* earlier document but published on or after the international filing date *L* document which may throw doubts on priority claim(s) or which is cited to establish the publication date of another citation or other special reason (as specified) *O* document referring to an oral disclosure, use, exhibition or other means *P* document published prior to the international filing date but later than the priority date claimed	*T* later document published after the international filing date or priority date and not in conflict with the application but cited to understand the principle or theory underlying the invention *X* document of particular relevance; the claimed invention cannot be considered novel or cannot be considered to involve an inventive step when the document is taken alone *Y* document of particular relevance; the claimed invention cannot be considered to involve an inventive step when the document is combined with one or more other such documents, such combination being obvious to a person skilled in the art. *&* document member of the same patent family
---	---

Date of the actual completion of the international search <b>1 September 2000</b>	Date of mailing of the international search report <b>12/09/2000</b>
--	---

Name and mailing address of the ISA European Patent Office, P.B. 5818 Patentlaan 2 NL - 2280 HV Rijswijk Tel. (+31-70) 340-2040, Tx. 31 651 epo nl, Fax: (+31-70) 340-3016	Authorized officer  <p style="text-align: center;"><b>Korth, C-F</b></p>
--	--

## INTERNATIONAL SEARCH REPORT

Inter. Application No

PCT/US 00/12515

## C.(Continuation) DOCUMENTS CONSIDERED TO BE RELEVANT

Category *	Citation of document, with indication, where appropriate, of the relevant passages	Relevant to claim No.
A	US 3 138 159 A (SCHMIDT ROSE) 23 June 1964 (1964-06-23) the whole document ---	1-33
A	US 4 139 006 A (COREY ARTHUR E) 13 February 1979 (1979-02-13) the whole document ---	1-33
A	US 4 307 716 A (DAVIS ALWYN K) 29 December 1981 (1981-12-29) the whole document -----	1-33

INTERNATIONAL SEARCH REPORT

Information on patent family members

International Application No

PCT/US 00/12515

Patent document cited in search report		Publication date	Patent family member(s)	Publication date			
WO 8810106	A	29-12-1988	CA 1322308	A 21-09-1993			
			AU 1948888	A 19-01-1989			
			DE 3874341	A 08-10-1992			
			DE 3874341	T 25-01-1996			
			EP 0363421	A 18-04-1990			
			HK 42794	A 13-05-1994			
			US 5045079	A 03-09-1991			
			AT 80029	T 15-09-1992			
			-----				
US 5483976	A	16-01-1996	US 5479945	A 02-01-1996			
			US 5090424	A 25-02-1992			
			AU 6916094	A 12-12-1994			
			CA 2163131	A 24-11-1994			
			EP 0699060	A 06-03-1996			
			WO 9426215	A 24-11-1994			
			US 5509427	A 23-04-1996			
			US 5752525	A 19-05-1998			
			AU 657940	B 30-03-1995			
			AU 9166091	A 17-08-1992			
			BR 9107193	A 21-06-1994			
			CA 2096632	A 01-07-1992			
			EP 0565616	A 20-10-1993			
			JP 6503982	T 12-05-1994			
			WO 9211826	A 23-07-1992			
			US 5513660	A 07-05-1996			
			US 5724994	A 10-03-1998			
			-----				
US 5336208	A	09-08-1994	US 5074855	A 24-12-1991			
			AT 182772	T 15-08-1999			
			CA 2100090	A 11-07-1992			
			DE 69229719	D 09-09-1999			
			DE 69229719	T 23-12-1999			
			EP 0566687	A 27-10-1993			
			ES 2137181	T 16-12-1999			
			GR 3031353	T 31-01-2000			
			JP 6506368	T 21-07-1994			
			WO 9211825	A 23-07-1992			
			US 5927282	A 27-07-1999			
			-----				
			US 5659934	A	26-08-1997	AU 712547	B 11-11-1999
AU 3670397	A 06-03-1998						
CA 2260848	A 19-02-1998						
CZ 9900453	A 15-09-1999						
EP 0955982	A 17-11-1999						
US 6039716	A 21-03-2000						
WO 9806366	A 19-02-1998						
-----							
US 3138159	A	23-06-1964	NONE				
-----							
US 4139006	A	13-02-1979	NONE				
-----							
US 4307716	A	29-12-1981	NONE				
-----							