

(19)
(12)

(KR)
(A)

(51) 。 Int. Cl. 7
H01L 29/786

(11)
(43)

2002 - 0096743
2002 12 31

(21) 10 - 2001 - 0035567
(22) 2001 06 21

(71) 136 - 1

(72) 가 6 601 - 1602

(74)
:

(54)

(Driver) , SRAM 3 (Stack)
(Load)
(Single Crystal Silicon Thin Film Transisto
r; C - Si TFT) (Load)
SPC(Solid Phase Crystallization)

4f

, SPC

1 SRAM

2a 2d 1

3a 3e 2

4a 4f

5

< >

21, 31, 41, 61 : 22, 47, 69 :

32 : 1 23, 33 :

34 : 2 24, 35, 50 :

25, 36, 51, 70 :

42, 62 : 43, 63 : p -

44, 65, 71 : 1 45, 66, 72 : 1

46, 67 : / 48 : 2

49 : 2 52, 73 : /

53, 74 : 64 : n -

68 : p A :

B : C, D, E :

T_D : T_L :

(Driver) , SRAM (Load) 3 (Stack)

, PDAs(Personal Digital Assistants)가 , , , 가 , 가
(Random Access Memory; RAM) 가 . DRAM 가 , 가

, SRAM (Driver) . SRAM , 4Mb (Soft Error) TFT . TFT . PMOS (Hold) 1 μ A (Stacking) SRAM 3 16Kb SRAM (Stack) TFT
 , 가 가 .
 ling down) (Active) 가 , (Sca 가
 . 가
 6
 (Floating) , (Subthreshold leakage
 current) 가 , (Body) (Stand - by power)가 가
 , (Driver)
 (Single Crystal Silicon Thin Film Transistor; C - Si TFT) , (Load)
 illization) SPC(Solid Phase Crysta

1 SRAM

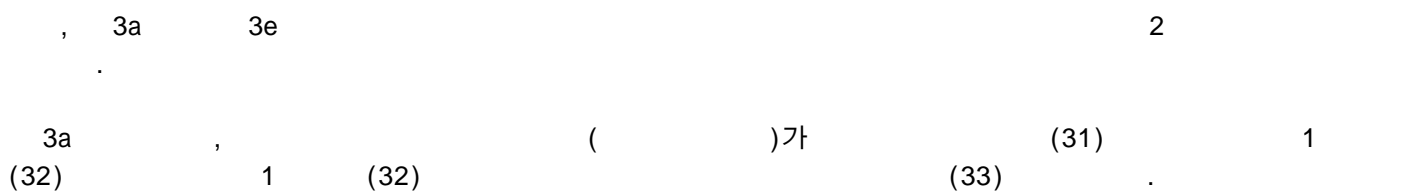
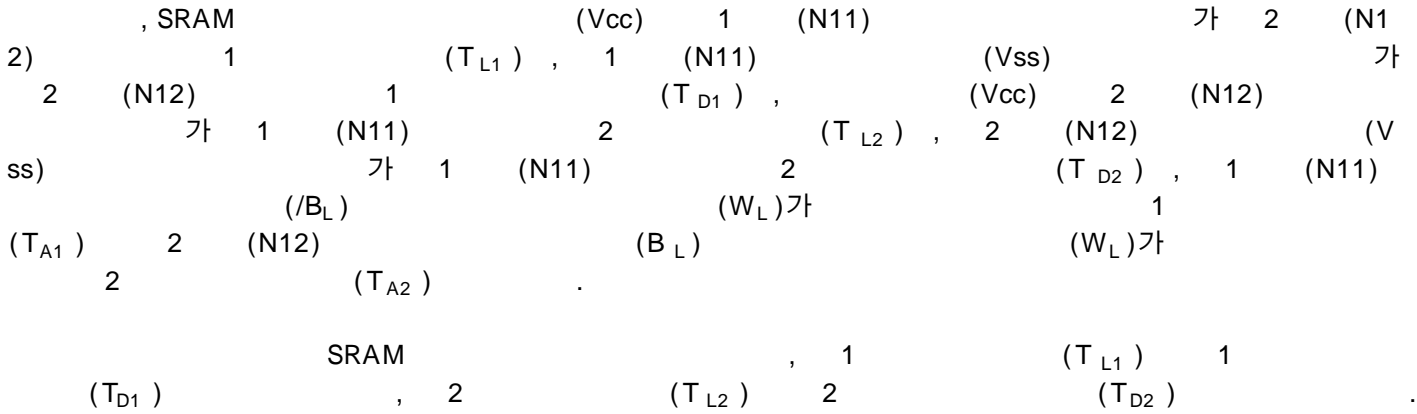

3b , (33) 1 (32) (31)

(B) (31)

3c , 2 (34) (B) 2 (34)

(B) (31)

3d , (B) 2 (34) (Amorphous silicon;

35)

3e , (Solid Phase Crystallization; SPC)

(34) (36)

(A) (21) (2c 23 , 3d 35) , 2c (B)

(31) (Seed) (Nucleation activ

ation energy)가 가 가

, 600 (Furnace annealing)

(Thermal budget) 3 (Stacked structure)

, 4a 4f ,

4a , (41) (42) p- (43)

, 1 , (44), 1 (45) (44), 1 (45) / (46) 가

4b , (47) 1 (45) (47)

2 (48)

4c , 2 (48) (47) 2 (49)

, 2 (49) 2 (48)

, 2 (49) (47) (46)

4d , (47) (46)

(60) (60)

4e , (Solid Phase Crystallization; SPC)

(51)

600

3

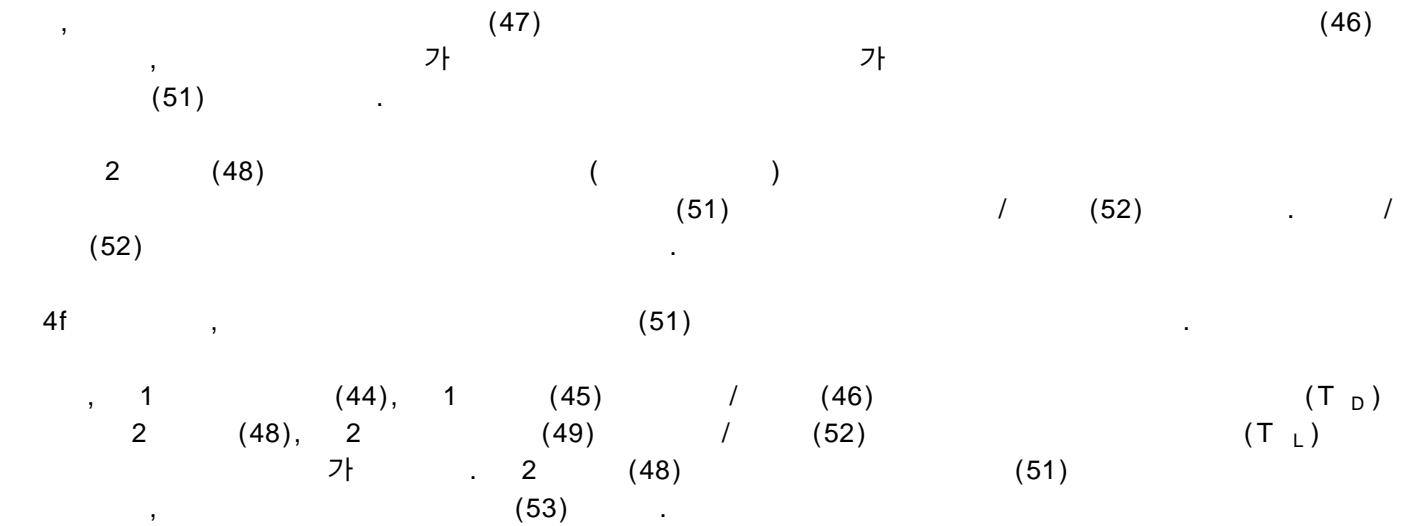

(Bottom gate poly - Si Thin Film Transistor)

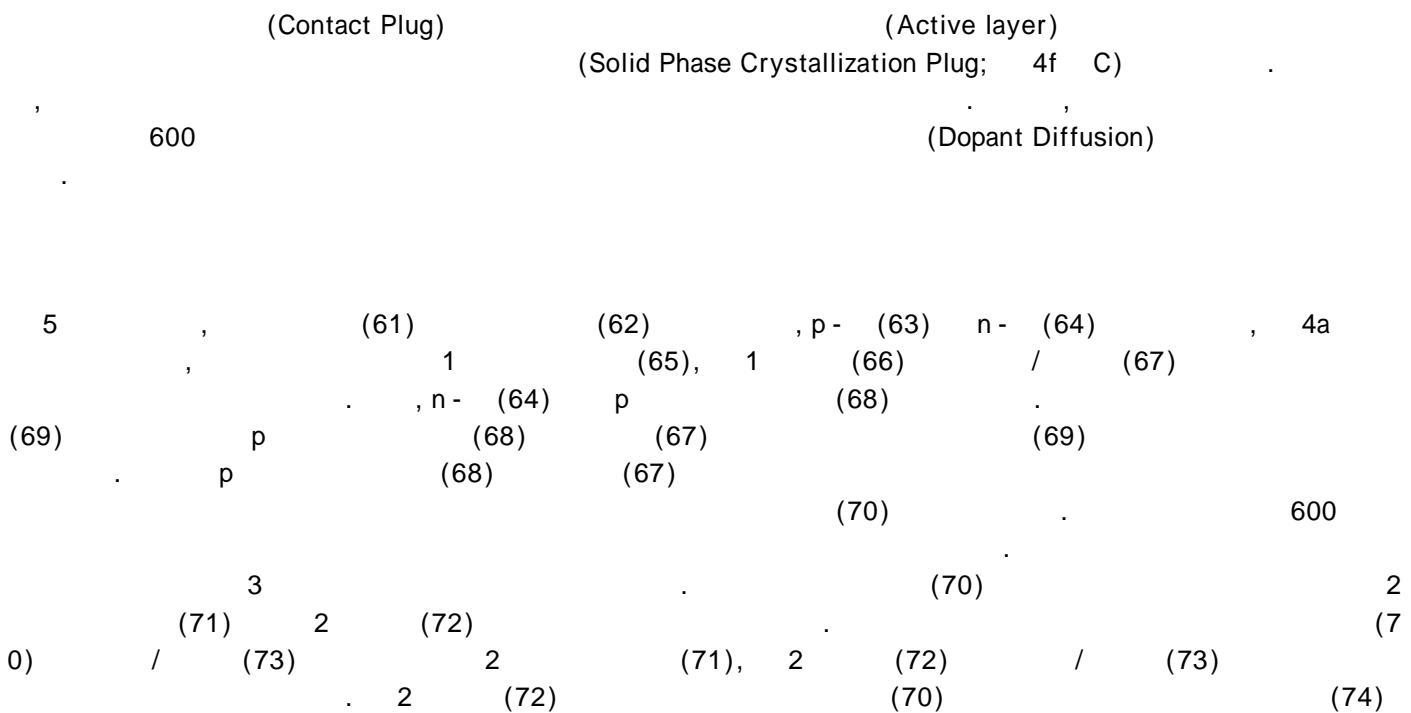

(Subthreshold current) (73) SPC (D) (Bottom) SPC (E) (Top gate) TFT (Double gate) TFT (67) (Stacked) SRAM (74)

(Driver)
 (Load)
 SPC 가 3 SRAM 가
 SPC

(57)

1.

;
 ;
 ;
 ;
 /

2.

1 ,
 600

3.

1 ,

4.

,
 ;
 ;
 ;

;

/

5.

4 ,

600

6.

4 ,

7.

4 ,

1

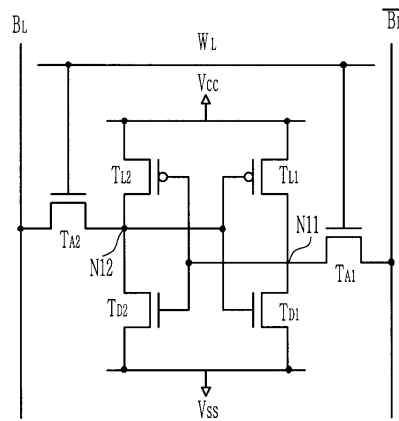

2

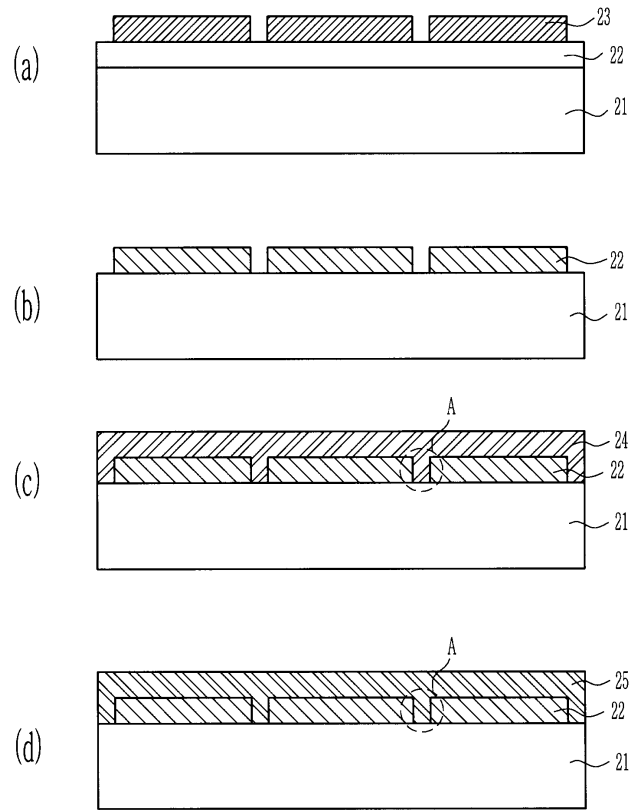

3a

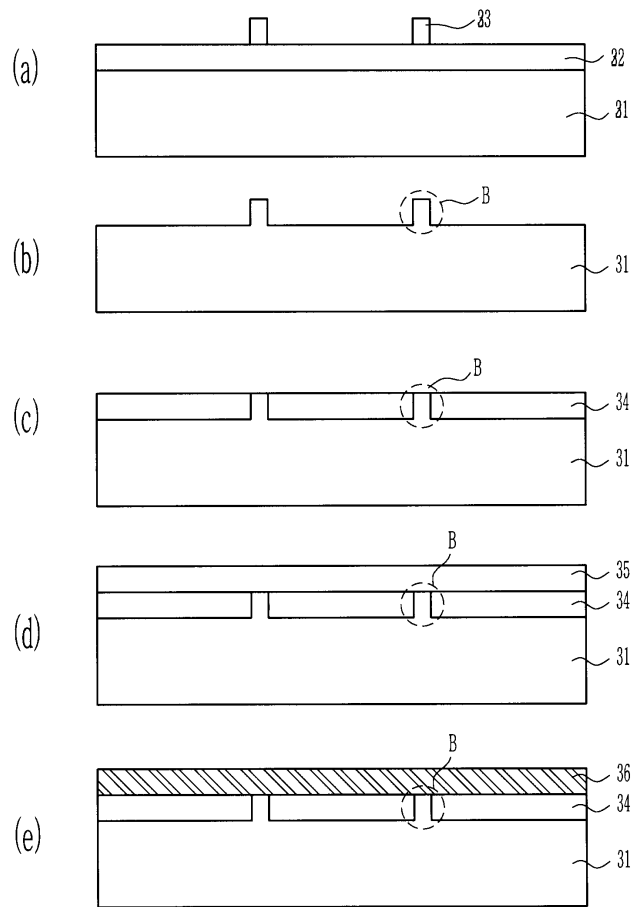

4a

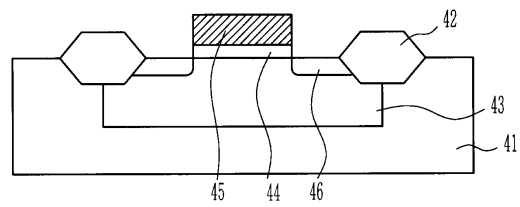

4b

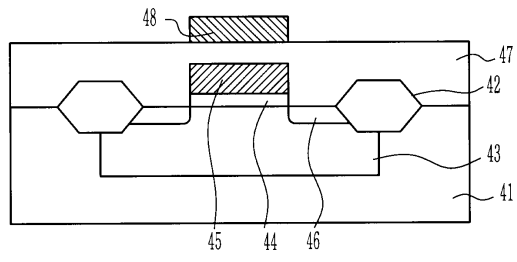

4c

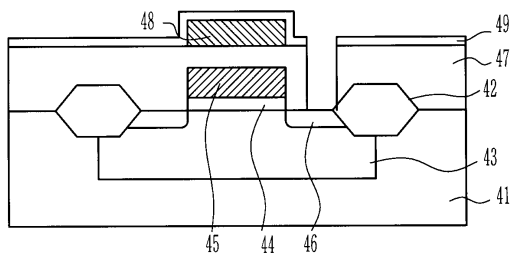

4d

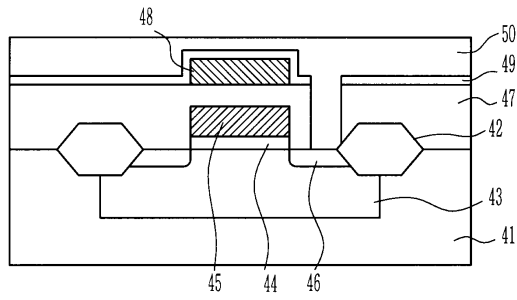

4e

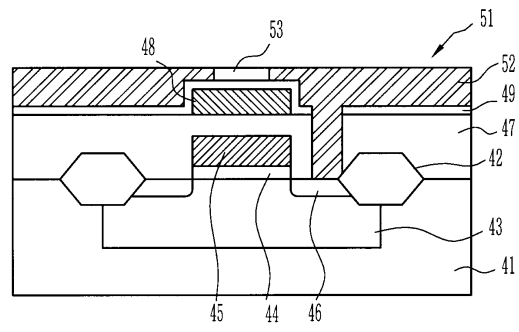

4f

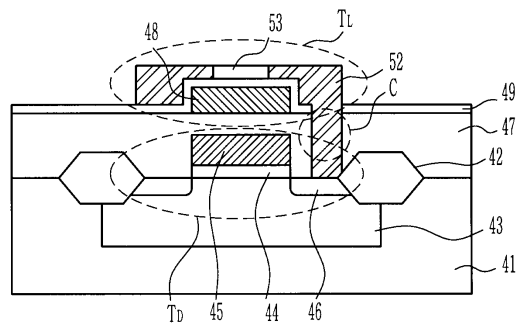

5

