



US00RE46078E

(19) **United States**
(12) **Reissued Patent**
Janna et al.

(10) **Patent Number:** **US RE46,078 E**
(45) **Date of Reissued Patent:** **Jul. 26, 2016**

(54) **HINDFOOT NAIL**

(56) **References Cited**

(75) Inventors: **Sied W. Janna**, Memphis, TN (US);
William Stewart, Austin, TX (US); **Roy**
W. Sanders, Tampa, FL (US)

U.S. PATENT DOCUMENTS

2,136,471 A	11/1938	Schneider
2,952,254 A	9/1960	Keating
2,987,062 A	6/1961	Ellison
3,272,204 A	9/1966	Artandi et al.
3,463,158 A	8/1969	Schmitt et al.
3,531,561 A	9/1970	Trebu et al.

(73) Assignee: **Smith & Nephew, Inc.**, Memphis, TN (US)

(Continued)

(21) Appl. No.: **13/483,742**

(22) Filed: **May 30, 2012**

FOREIGN PATENT DOCUMENTS

CH	669898	4/1989
DE	1949923	4/1971

(Continued)

Related U.S. Patent Documents

Reissue of:

(64) Patent No.: **7,410,488**
Issued: **Aug. 12, 2008**
Appl. No.: **11/061,699**
Filed: **Feb. 18, 2005**

OTHER PUBLICATIONS

Office Action for U.S. Appl. No. 13/614,006, mailed Sep. 5, 2014.
(Continued)

U.S. Applications:

(62) Division of application No. 12/855,377, filed on Aug. 12, 2010, now Pat. No. Re. 44,501, which is an application for the reissue of Pat. No. 7,410,488.

Primary Examiner — Cary E. Wehner

(74) *Attorney, Agent, or Firm* — Fish & Richardson P.C.

(51) **Int. Cl.**
A61B 17/58 (2006.01)
A61B 17/72 (2006.01)

(57) **ABSTRACT**

The present invention relates to a nail and fastener assembly for use in providing a stable construct for optimal fixation of the hindfoot and to methods for implanting the nail and fastener assembly. One embodiment of the nail and fastener assembly provides additional fixation, for example, in the form of one or more threaded bores, to hold the fasteners in a fixed position. Another embodiment provides angled bores to allow multi-planar and multi-axial implantation of the fasteners. In some instances, the fasteners may cross one or more articulating surfaces of the foot. For example, the fastener may traverse one or more of the calcaneo-cuboid and the talo-calcaneal articulating surfaces to aid in more secure stabilization of the hindfoot.

(52) **U.S. Cl.**
CPC **A61B 17/72** (2013.01); **A61B 17/725** (2013.01); **A61B 17/7233** (2013.01); **A61B 17/7291** (2013.01)

(58) **Field of Classification Search**
CPC A61C 17/7291
USPC 606/62-68; 623/21.18
See application file for complete search history.

23 Claims, 6 Drawing Sheets

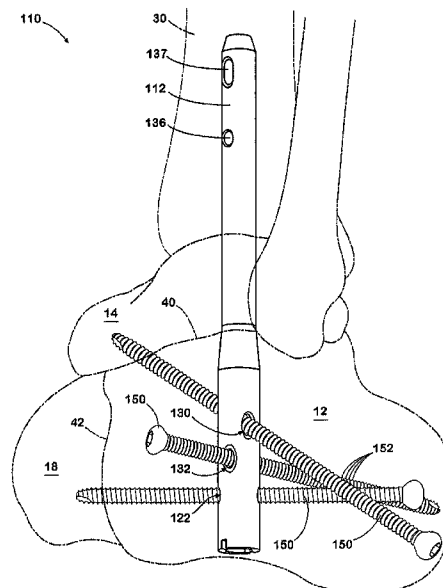

(56)

References Cited

U.S. PATENT DOCUMENTS

3,596,656 A	8/1971	Kaute	5,413,577 A	5/1995	Pollock	
3,636,956 A	1/1972	Schneider	5,441,500 A	8/1995	Seidel et al.	
3,739,773 A	6/1973	Schmitt et al.	5,458,654 A	10/1995	Tepic	
3,876,068 A	4/1975	Sonnino	5,472,444 A	12/1995	Huebner et al.	
3,892,649 A	7/1975	Phillips et al.	5,484,438 A	1/1996	Pennig	
3,902,497 A	9/1975	Casey	5,501,695 A	3/1996	Anspach, Jr. et al.	
3,918,100 A	11/1975	Shaw et al.	5,514,137 A	5/1996	Coutts	
3,937,223 A	2/1976	Roth	5,520,690 A	5/1996	Errico et al.	
3,960,151 A	6/1976	Kuhn	5,549,610 A	8/1996	Russell et al.	
4,135,507 A	1/1979	Hararis	5,569,250 A	10/1996	Sarver et al.	
4,146,936 A	4/1979	Aoyagi et al.	5,584,836 A	12/1996	Ballintyn et al.	
4,186,448 A	2/1980	Brekke	5,603,715 A	2/1997	Kessler	
4,191,185 A	3/1980	Lemieux	5,618,286 A	4/1997	Brinker	
4,192,021 A	3/1980	Deibig et al.	5,653,709 A	8/1997	Frigg	
4,219,015 A	8/1980	Steinemann	5,658,287 A	8/1997	Hofmann et al.	
4,279,249 A	7/1981	Vert et al.	5,662,472 A	9/1997	Grutzner	
4,280,233 A	7/1981	Raab	5,713,902 A *	2/1998	Friedl	606/64
4,292,694 A	10/1981	Koeneman	5,720,766 A	2/1998	Zang et al.	
4,338,926 A	7/1982	Kummer et al.	5,725,541 A	3/1998	Anspach, III et al.	
4,429,690 A	2/1984	Angelino-Pievani	5,730,744 A	3/1998	Justin et al.	
4,457,301 A	7/1984	Walker	5,741,266 A	4/1998	Moran et al.	
4,465,065 A	8/1984	Gotfried	5,741,282 A	4/1998	Anspach, III et al.	
4,475,545 A	10/1984	Ender	5,743,914 A	4/1998	Skiba	
4,503,847 A	3/1985	Mouradian	5,766,174 A *	6/1998	Perry	606/62
4,522,202 A	6/1985	Otte et al.	5,776,194 A	7/1998	Mikol et al.	
4,523,591 A	6/1985	Kaplan et al.	5,792,400 A	8/1998	Talja et al.	
4,550,449 A	11/1985	Tunc	5,810,821 A	9/1998	Vandewalle	
4,612,923 A	9/1986	Kronenthal	5,836,949 A	11/1998	Campbell, Jr. et al.	
4,622,959 A	11/1986	Marcus	5,855,579 A	1/1999	James et al.	
4,644,943 A	2/1987	Thompson et al.	5,868,746 A	2/1999	Sarver et al.	
4,655,203 A	4/1987	Tormala et al.	5,871,484 A	2/1999	Spievack et al.	
4,705,027 A	11/1987	Klaue	5,876,402 A	3/1999	Errico et al.	
4,733,654 A	3/1988	Marino	5,879,389 A	3/1999	Koshino	
4,751,183 A	6/1988	Sonneborn et al.	5,895,390 A	4/1999	Moran et al.	
4,756,307 A	7/1988	Crowninshield	5,927,978 A	7/1999	Muller	
4,776,330 A	10/1988	Chapman et al.	5,928,267 A	7/1999	Bonutti et al.	
4,781,183 A	11/1988	Casey et al.	5,935,127 A	8/1999	Border	
4,790,302 A	12/1988	Colwill et al.	6,004,323 A	12/1999	Park et al.	
4,846,162 A *	7/1989	Mochring	6,015,937 A	1/2000	Branemark	
4,851,008 A	7/1989	Johnson	6,019,761 A	2/2000	Gustilo	
4,863,475 A	9/1989	Andersen et al.	6,053,918 A	4/2000	Spievack	
4,875,474 A	10/1989	Border	6,106,528 A	8/2000	Durham et al.	
4,875,475 A	10/1989	Comte et al.	6,120,504 A	9/2000	Brumback et al.	
4,895,572 A	1/1990	Chernoff	6,123,708 A	9/2000	Kilpela et al.	
4,896,661 A	1/1990	Bogert et al.	6,168,595 B1	1/2001	Durham et al.	
4,898,186 A	2/1990	Ikada et al.	6,197,029 B1	3/2001	Fujimori et al.	
4,911,153 A	3/1990	Border	6,228,086 B1	5/2001	Wahl et al.	
4,919,666 A	4/1990	Buchhorn et al.	6,248,108 B1	6/2001	Tormala et al.	
4,943,292 A	7/1990	Foux	6,261,291 B1	7/2001	Talaber et al.	
4,968,317 A	11/1990	Tormala et al.	6,270,304 B1	8/2001	Freedland	
4,973,333 A	11/1990	Treharne	6,270,499 B1	8/2001	Leu et al.	
4,976,258 A	12/1990	Richter et al.	6,296,645 B1	10/2001	Hover et al.	
4,989,186 A	1/1991	Ricker	6,309,392 B1	10/2001	Alexander et al.	
5,009,664 A	4/1991	Sievers	6,319,253 B1	11/2001	Ackeret et al.	
5,034,013 A	7/1991	Kyle et al.	6,368,319 B1	4/2002	Schaefer	
5,035,697 A	7/1991	Frigg	6,383,187 B2	5/2002	Tormala et al.	
5,041,114 A	8/1991	Chapman et al.	6,443,954 B1	9/2002	Bramlet et al.	
5,057,110 A	10/1991	Kranz et al.	6,488,684 B2	12/2002	Bramlet et al.	
5,057,111 A	10/1991	Park	6,514,253 B1	2/2003	Yao	
5,066,296 A	11/1991	Chapman et al.	6,524,314 B1	2/2003	Dean et al.	
5,084,050 A	1/1992	Draenert	6,527,775 B1	3/2003	Warburton	
5,084,051 A	1/1992	Tormala et al.	6,572,620 B1	6/2003	Schon et al.	
5,108,399 A	4/1992	Eitenmuller et al.	6,572,655 B1	6/2003	Johnson	
5,112,333 A	5/1992	Fixel	6,579,293 B1 *	6/2003	Chandran	606/64
5,123,911 A	6/1992	Granger et al.	6,602,255 B1	8/2003	Campbell et al.	
5,127,913 A	7/1992	Thomas, Jr.	6,605,090 B1	8/2003	Trieu et al.	
5,190,546 A	3/1993	Jervis	6,626,906 B1	9/2003	Young	
5,201,735 A	4/1993	Chapman et al.	6,673,116 B2	1/2004	Reiley	
5,236,431 A	8/1993	Gogolewski et al.	6,706,046 B2	3/2004	Orbay et al.	
5,248,313 A	9/1993	Greene et al.	6,709,436 B1	3/2004	Hover et al.	
5,250,049 A	10/1993	Michael	6,730,093 B2	5/2004	Saint Martin	
5,263,431 A	11/1993	Wood	6,755,834 B2	6/2004	Amis	
5,269,784 A	12/1993	Mast	6,783,529 B2	8/2004	Hover et al.	
5,275,601 A	1/1994	Gogolewski et al.	6,786,908 B2	9/2004	Hover et al.	
5,292,695 A	3/1994	Galloway	6,926,720 B2	8/2005	Castenada	
			6,951,561 B2	10/2005	Warren et al.	
			7,247,156 B2 *	7/2007	Ekholm et al.	606/64
			7,588,577 B2 *	9/2009	Fencl et al.	606/96
			7,655,009 B2	2/2010	Grusin	

(56)

References Cited

U.S. PATENT DOCUMENTS

2001/0021851	A1	9/2001	Eberlein et al.	
2001/0031966	A1	10/2001	Tormala et al.	
2001/0037112	A1	11/2001	Brace et al.	
2002/0029041	A1	3/2002	Hover et al.	
2002/0062128	A1	5/2002	Amis	
2002/0072748	A1	6/2002	Robioneck	
2002/0133156	A1	9/2002	Cole	
2002/0133158	A1	9/2002	Saint Martin	
2002/0151898	A1	10/2002	Sohngen et al.	
2003/0009219	A1	1/2003	Seyr et al.	
2003/0018336	A1	1/2003	Vandewalle	
2003/0055428	A1	3/2003	Swanson	
2003/0069581	A1	4/2003	Stinson et al.	606/62
2003/0078583	A1	4/2003	Biedermann et al.	
2003/0097131	A1	5/2003	Schon et al.	
2003/0195515	A1	10/2003	Sohngen	
2003/0199876	A1	10/2003	Brace et al.	
2004/0030342	A1	2/2004	Trieu et al.	
2004/0092942	A1	5/2004	Reiley	
2004/0097935	A1	5/2004	Richelsof et al.	
2004/0127899	A1	7/2004	Konieczynski et al.	
2004/0127900	A1	7/2004	Konieczynski et al.	
2004/0127904	A1	7/2004	Konieczynski et al.	
2004/0158252	A1	8/2004	Prager et al.	
2004/0172026	A1*	9/2004	Ekholm et al.	606/62
2004/0260290	A1	12/2004	Zander et al.	
2005/0101958	A1	5/2005	Adam	
2005/0187550	A1	8/2005	Grusin	
2005/0261555	A1	11/2005	Guzman et al.	
2006/0100623	A1	5/2006	Pennig	
2006/0173457	A1*	8/2006	Tornier	606/62
2007/0123878	A1	5/2007	Shaver et al.	
2008/0015587	A1	1/2008	Munoz	
2008/0287949	A1	11/2008	Keith et al.	

FOREIGN PATENT DOCUMENTS

DE	196 29 011	A1	1/1998	
DE	19629011		1/1998	
DE	19945611		9/2001	
DE	203 00 987	U1	4/2003	
DE	20300987		5/2003	
DE	20309 399	U1	8/2003	
DE	20309399		10/2003	
DE	19945611		11/2005	
EP	0 299 004	B1	1/1989	
EP	0 355 411	A1	2/1990	
EP	0355411		2/1990	
EP	0 491 983	A1	7/1992	
EP	0 583 442	B1	2/1994	
EP	0299004		3/1994	
EP	0491983		3/1996	
EP	0 710 091	B2	5/1996	
EP	0710091		5/1996	
EP	0583442		10/1996	
EP	1 415 604	A1	5/2004	
EP	1415604		5/2004	
FR	2710835		4/1995	
SU	1692566		11/1991	
SU	1692566	A1	11/1991	
WO	WO96/35387		11/1996	
WO	WO 98/41161		9/1998	
WO	WO98/46169		10/1998	
WO	WO98/41161		12/1998	
WO	WO 00/61018		10/2000	
WO	WO00/61018		6/2002	
WO	WO03/17822		3/2003	

OTHER PUBLICATIONS

McKellop, et al., Development and Clinical Performance of a Reversible Titanium Alloy Femoral Intramedullary Nail, Scientific Exhibit #3512, American Academy of Orthopaedic Surgeons, 58th Annual Meeting, Mar. 7-11, 1991.

Raiha, 'Biodegradable Implants as Intramedullary Nails. A Survey of Recent Studies and an Introduction to Their Use,' *Clinical Materials*, 10:35-39 (1992).

Hofmann, 'Editorial Biodegradable Implants in Orthopaedic Surgery,' *Clinical Materials*, 10:1 Table of Contents (1992).

"Alta Modular Trauma System . . . The leading edge in fracture management technology . . . the alta® tibial/humeral rod module for reamed and non-reamed procedures," 10 pages, Jan. 1992.

Kato, et al., The Weakest Link in the Bone Plate Fracture System: Changes with Time, *Clinical and Laboratory Performance of Bone Plates*, ASTM STP 1217, ed. By Harvey and Games, pp. 85-94, (1994).

Nazre, et al., 'Theoretical Strength Comparison of Bioabsorbable (PLLA) Plates and Conventional Stainless Steel and Titanium Plates Used in Internal Fracture Fixation,' *Clinical and Laboratory Performance of Bone Plates*, ASTM STP 1217, J.P. Harvey, Jr., and R. F. Games, Eds., American Society for Testing and Materials, Philadelphia, 1994, pp. 53-64.

Yeadon, et al., 'Influence of Axially Flexible Plates on Bone Healing: A Biomedical Study in Canine Femora,' *CMBES 20 CCGB Vancouver 1994*, pp. 34-35.

Rommens, et al., "Retrograde locked nailing of humeral shaft fractures: A review of 39 patients," *J. Bone Joint Surg. Br.*, 77(4):667, (1995) <http://www.ncbi.nlm.nih.gov/entrez/query.fcgi?cmd=Retrieve&db=PubMed&dopt=Abstra> . . .

Biomet, Inc. Brochure 'Uniflex® Surgical Technique,' pp. 1-16, 1995.

Biomet Inc. Vector Intertrochanteric Nail, Version Two, 19 pages, 1995.

Ferguson, et al., 'Finite element stress analysis of a hybrid fracture fixation plate,' *Med. Eng. Phys.*, 10(5):241-250, 1996.

Foux, et al., 'Improved Fracture Healing with Less Rigid Plates A Biomedical Study in Dogs,' *Clinical Orthopaedics and Related Research*, 339:232-245, 1997.

Simon, et al., Bioresorbable Fracture Fixation in Orthopedics: A Comprehensive Review. Part II. Clinical Studies, *The American Journal of Orthopedics*, pp. 754-762, (Nov. 1997).

Smith & Nephew Brochure entitled "Intramedullary Supracondylar Nail Surgical Technique," by David Seligson, M.D., et al., pp. 1-29 (Mar. 1998).

<http://www.biometmerck.com/english/products/trauma/ankle/htm>, on page, Jan. 6, 2005.

Orthofix Operative Technique Brochure entitled 'The Ankle Arthrodesis Nail,' by Profs. Dr. D. Pennig, 16 pages, 2002.

DePuy website paper entitled The VersaNail System: A Versatile Ankle Fusion Option, pp. 1-3 (copyright 2002-2004).

Dr. Rodriguez's www.chicagofootandanklesurgery.com (Ankle Fusion) web page, pp. 1-3 (Mar. 11, 2005 <http://www.cfaas.com/anklefusion.htm>).

Encore: True/Fix® Proximal Humeral Nail web page, pp. 1-2, Jan. 19, 2005 http://www.encoremed.com/orthopedics/products/trauma/proximal_humeral_nail.html.

EPI Products website paper entitled "Excellence by Innovation" one page, undated.

Brochure of Intramedullary Nail. One Nail . . . Diaphyseal Fractures, 1993.

URTN System Introduction, The Titanium Unreamed Tibial Nail System: the next generation in Unreamed Tibial Nails from Synthes and the AO/ASIF, one page, 1993.

Ordway, Craig B., AIM Titanium Femoral Nail System Surgical Technique, Ace Medical Company, pp. 1-8, 1994.

Brochure entitled "Stryker T2™ Proximal Humeral Nailing System Operative Technique" Stryker Trauma®, 20 pages, 2003.

Office Action for U.S. Appl. No. 12/855,377, mailed Aug. 29, 2012.

Office Action for U.S. Appl. No. 12/855,377, mailed Apr. 10, 2012.

Office Action for U.S. Appl. No. 13/614,006, mailed Mar. 19, 2013.

Communication Pursuant to Article 94(3) EPC for European Application No. 06735179.1, mailed Aug. 24, 2015.

Biomet, Inc. Brochure 'Uniflex® Surgical Technique,' pp. 1-12, 1995.

Biomet, Inc. Medical Products Brochure, Uniflex® Nailing System, pp. 1-14 (1995).

(56)

References Cited

OTHER PUBLICATIONS

Biomet, Inc. Medical Products Brochure, Trauma Systems Uniflex™ Tibial Nail System, 4 pages (1995).
Biomet Inc., Biomet Retrograde Femoral Nail, 6 pages, 1995.
Biomet Inc., Biomet Retrograde Femoral Nail Surgical Technique, 12 pages, 1995.
Biomet Inc., AIM™ Titanium Femoral Nail, 11 pages, 1995.
Biomet, Inc., Vector Intertrochanteric Nail, Version One, 18 pages, 1995.
Brochure of Intramedullary Nail. One Nail . . . Diaphyseal Fractures. URTN System Introduction, The Titanium Unreamed Tibial Nail

System: the next generation in Unreamed Tibial Nails from Synthes and the AO/ASIF, one page.
Parts List, undated.
Biomet Medical Products Inc. 'Interlocking Nail,' 14 pages, 1995.
Ferguson, et al., 'Finite element stress analysis of a hybrid fracture fixation plate,' Med. Eng. Phys., 10(5):2410-250 (1996).
Orthofix Retrograde Nailing System, 'The long and the short of it,' Orthofix Always Inovating Brochure, 10 pages, 2002.
Orthofix Operative Technique Brochure entitled 'The Ankle Arthrodesis Nail,' by Prof. Dr. D. Penning, 16 pages, 2002.
Two sheets of schematic drawings of nail marked as 'Drawing Printed 81006321B,' and one sheet of 'Period Sales Analysis by Planner' showing first sale date of Sep. 2003.

* cited by examiner

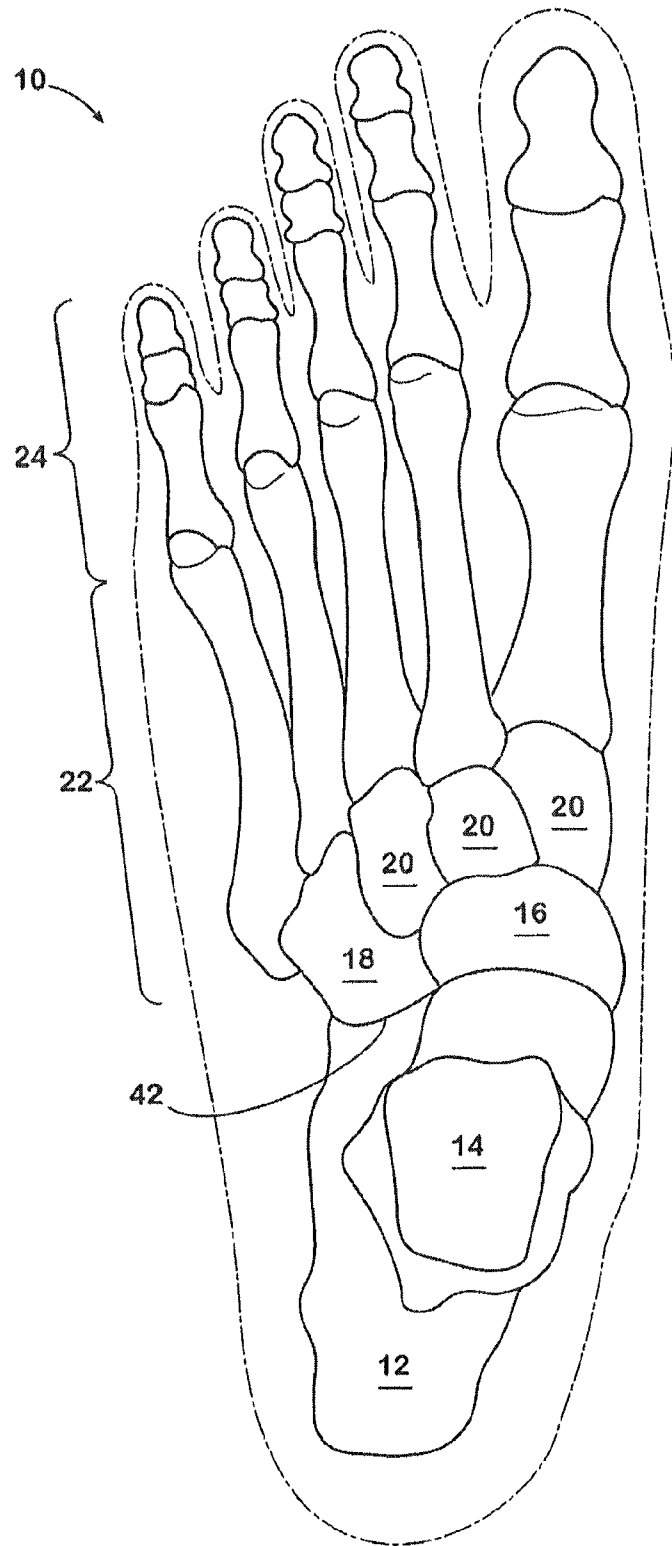

FIG 1

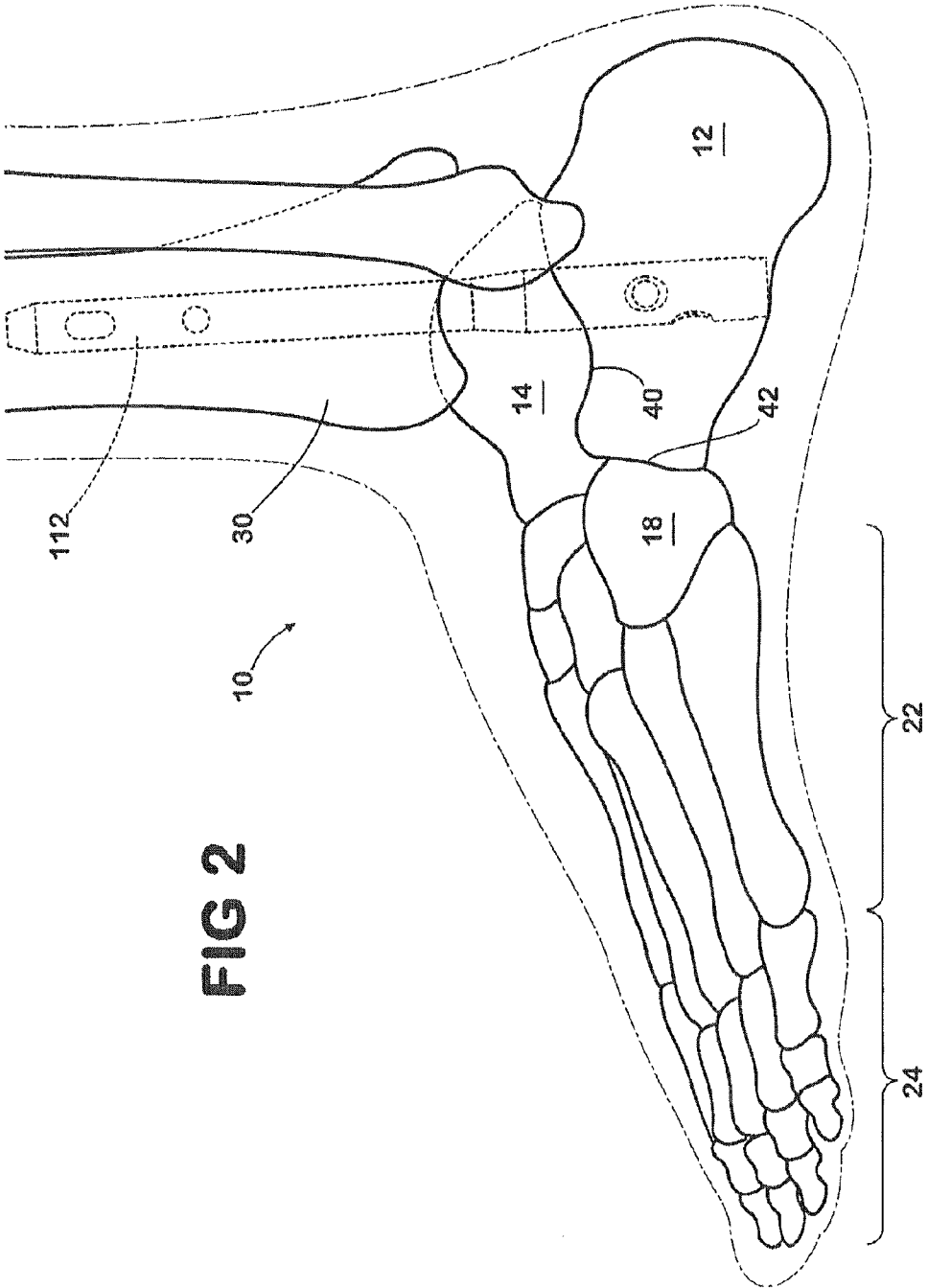

FIG 2

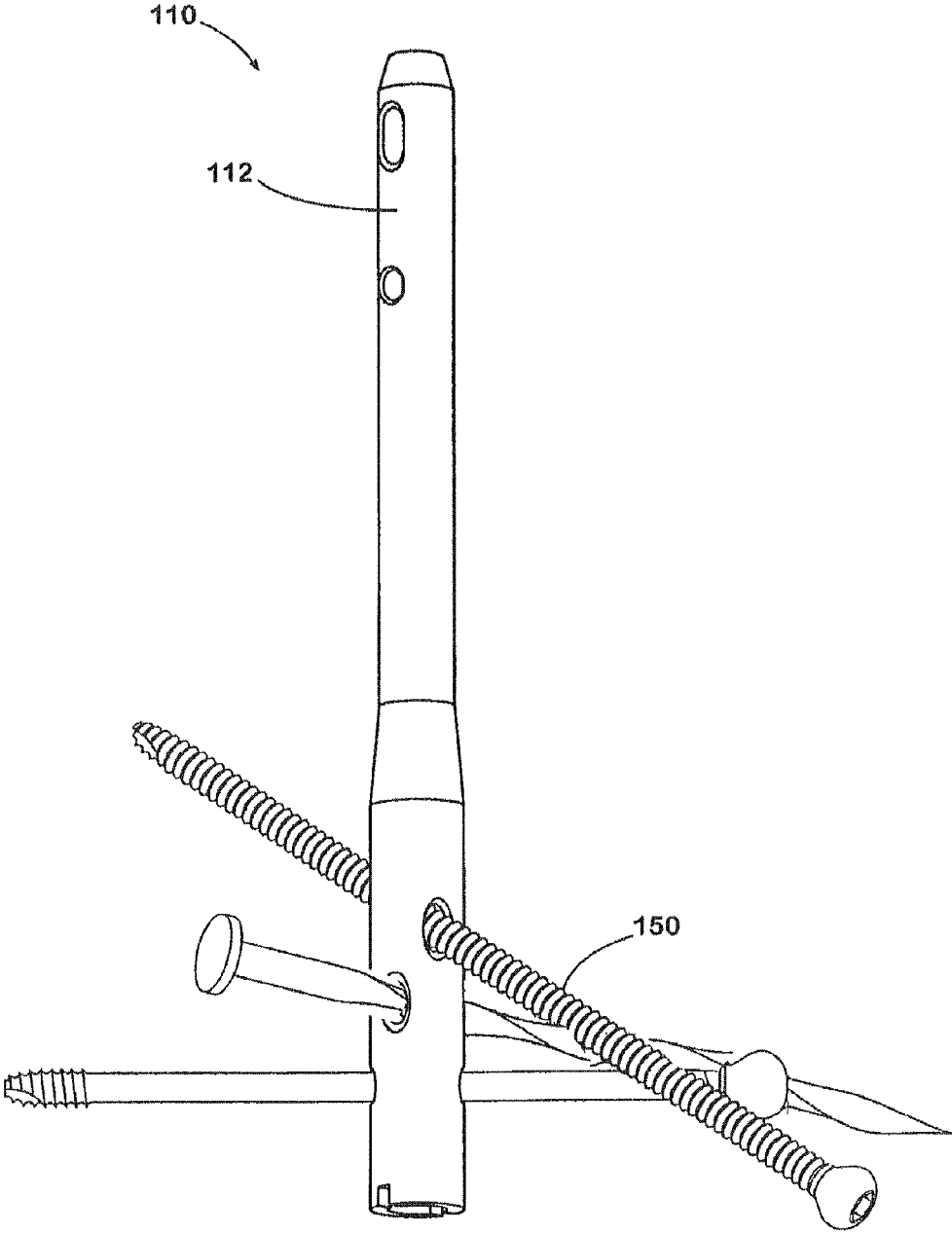

FIG 3

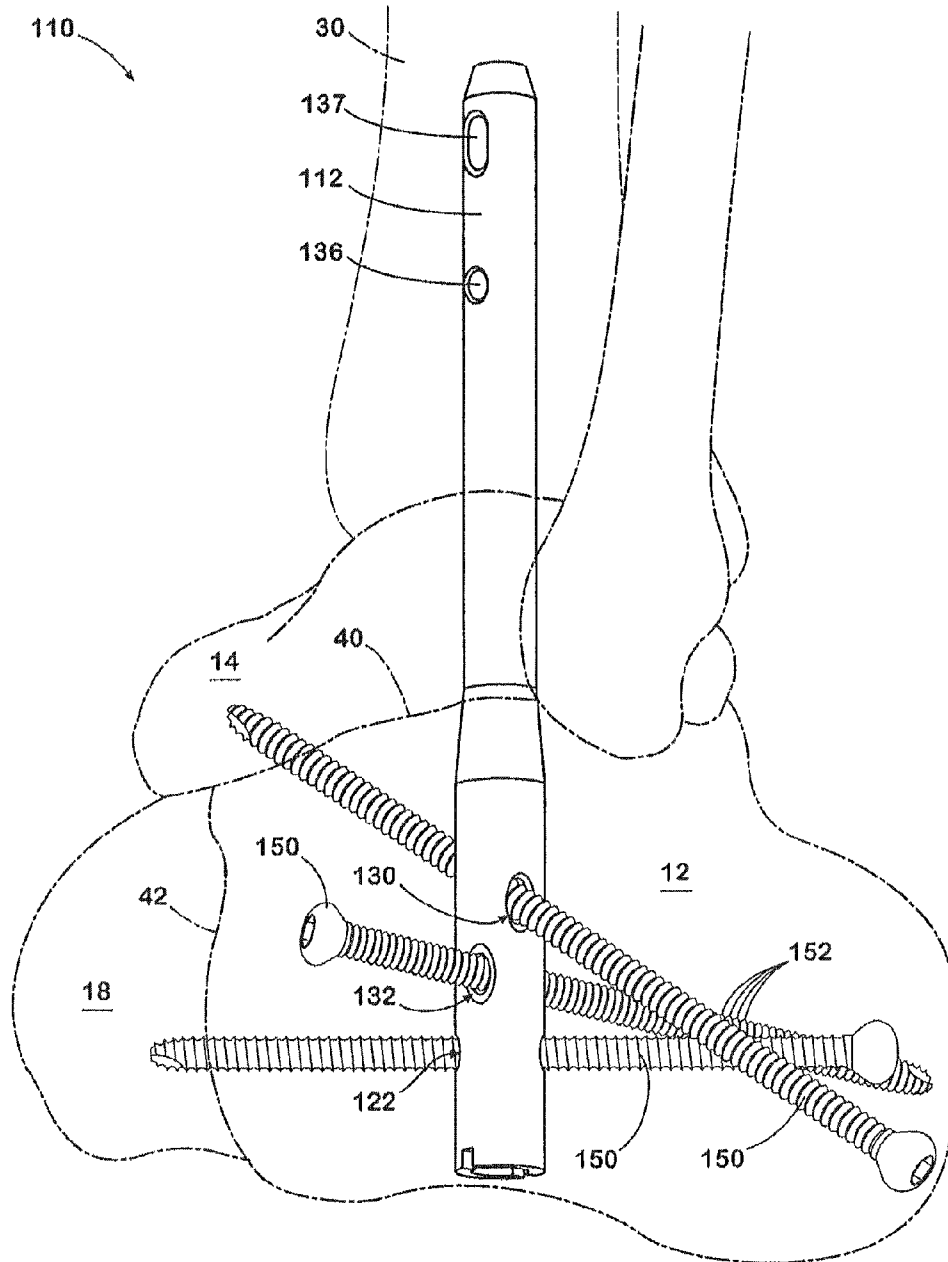

FIG 3A

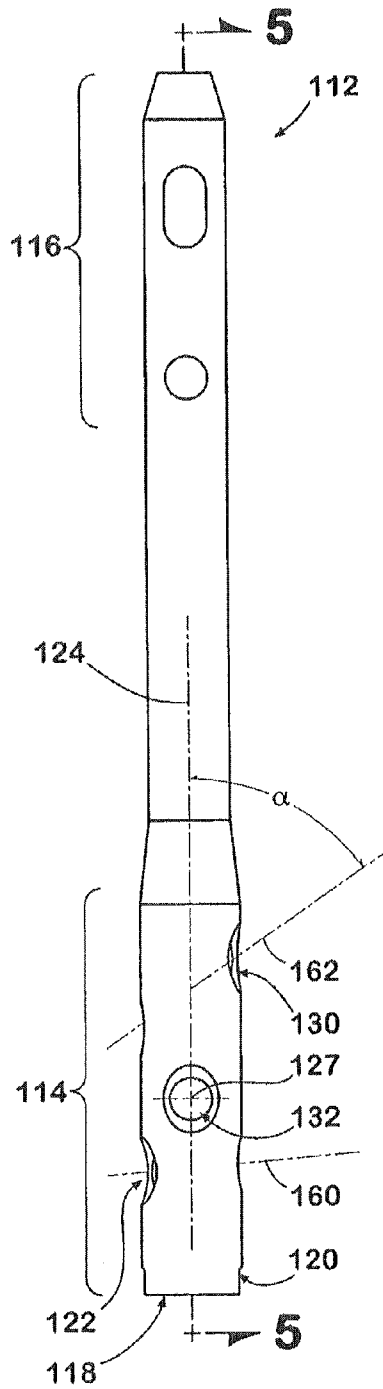

FIG 4

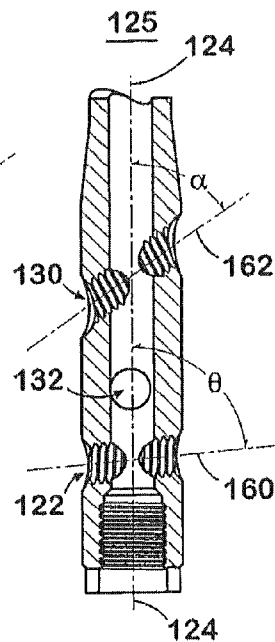

FIG 4A

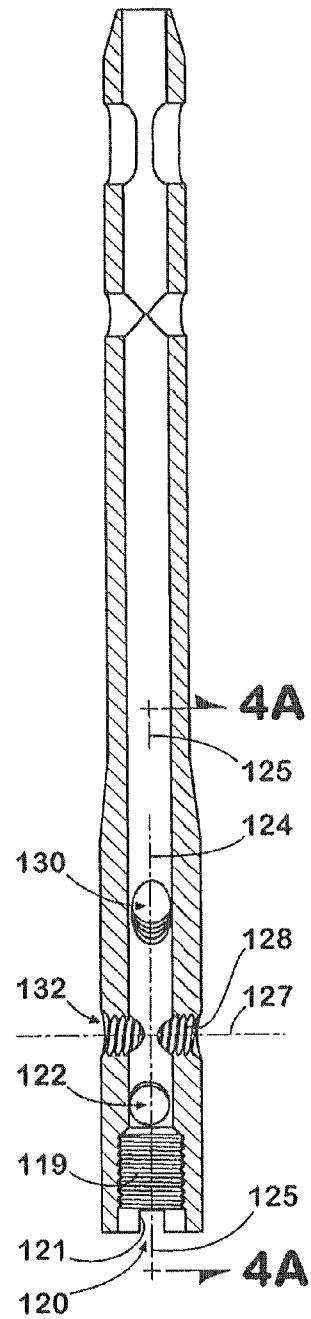

FIG 5

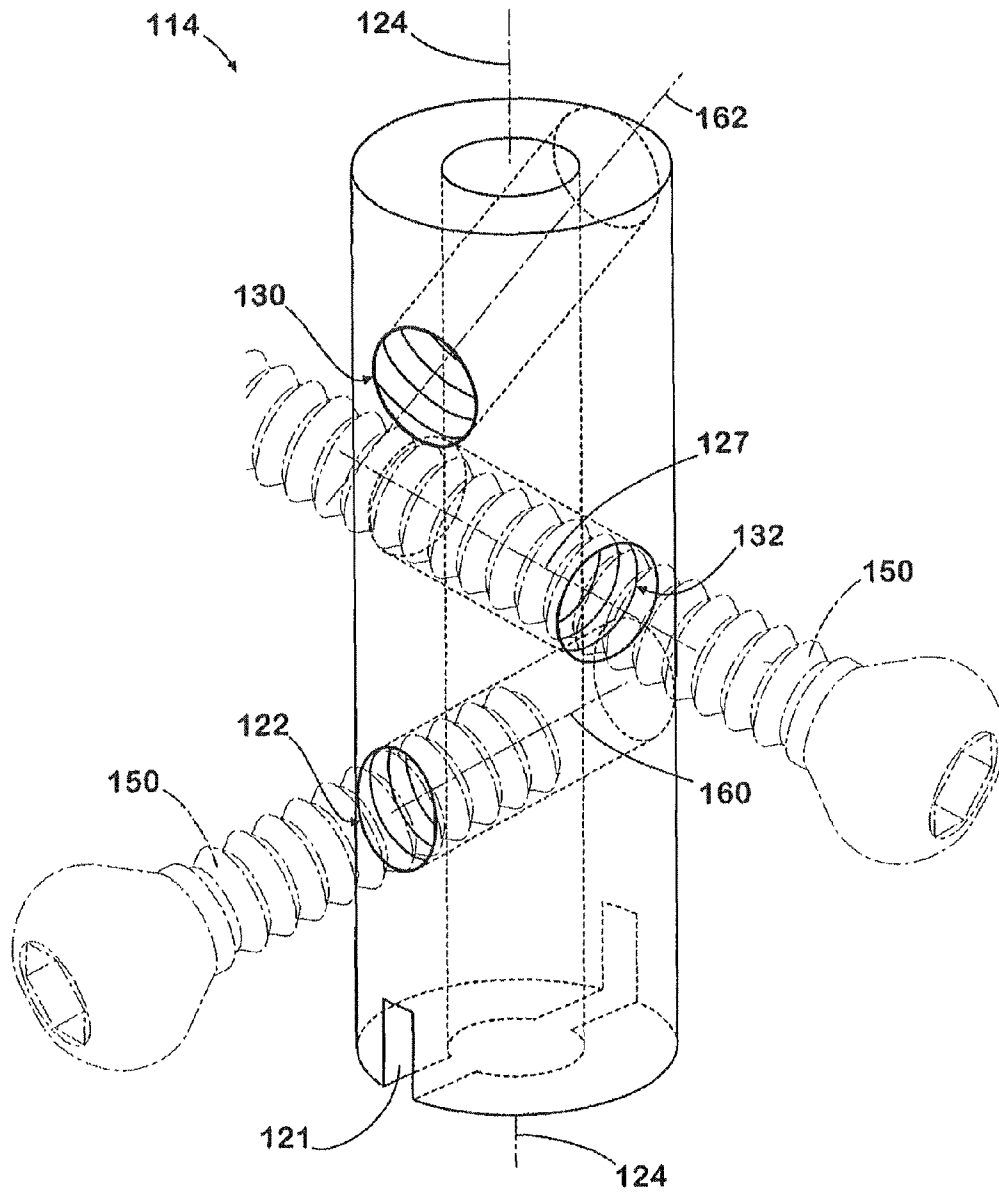

FIG 6

HINDFOOT NAIL

Matter enclosed in heavy brackets [] appears in the original patent but forms no part of this reissue specification; matter printed in italics indicates the additions made by reissue; a claim printed with strikethrough indicates that the claim was canceled, disclaimed, or held invalid by a prior post-patent action or proceeding.

Notice: More than one reissue application has been filed for the reissue of U.S. Pat. No. 7,410,488. The reissue applications are the present application, which is a divisional reissue, U.S. patent application Ser. No. 12/855,377, which is reissued as U.S. Pat. No. Re. 44,501 on Sep. 17, 2013, and U.S. patent application Ser. No. 13/614,006, which is a continuation reissue.

FIELD OF THE INVENTION

The invention relates to nail and fastener assemblies that provide stable fixation of the hindfoot.

BACKGROUND

Serious ankle problems can be caused by a number of conditions, such as arthritis (e.g., osteoarthritis, rheumatoid arthritis), diabetes, trauma, accidents, or severe deformation. One solution is to replace the ankle joint with an implant or ankle prosthesis. However, prostheses often fail due to subsidence, wear, and loosening within a few years following implantation. There are also anatomical considerations that make such implants non-feasible in some cases. Poor results with prostheses have led many surgeons to abandon implant arthroplasty in more serious cases and return to ankle arthrodesis—fusing the joint to ultimately result in bone fusion. Often, by the time fusion is selected as the best option, there is minimal motion at the joint prior to surgery.

Ankle fusion typically involves using screws and pins to hold the bone together. In a typical fusion surgery, the ankle joint is fused, allowing the tibia (shinbone) to grow together or fuse with the talus bone, the bone of the ankle that articulates with the tibia and fibula, and the calcaneus, the bone that forms the ankle joint. A long ankle arthrodesis “nail” may be inserted through the heel and fixed into place with screws or pins. Often, one or more screws or pins are inserted into the calcaneus, the bone at the lower back part of the foot forming the heel, which provides more stability.

Many of the currently available ankle fusion systems are less than optimal. One reason is because the screws or pins used to fuse the foot bones are secured only into the foot bones themselves; they are not secured to the ankle arthrodesis nail through which they are received. In some instances, an unsecured screw or pin can dislodge itself from the patient’s bone and migrate out over years of use. Thus, there is a need in the art to provide a better solution to reduce the risk of migration.

Another reason that many of the currently available fusion systems are less than optimal is because they do not have angled fastener-receiving holes that allow for multi-planar fixation. Alternatively, if angled holes are present, they are not provided at optimal angle ranges for securing and immobilizing the ankle.

In some commercially available systems, the center of the fastener-receiving hole opening(s) in the ankle arthrodesis nail is perpendicular to the longitudinal axis of the nail, such

that when the fastener is inserted, it is also perpendicular to the nail. This does not allow the surgeon to achieve purchase into preferred bones of the foot, but instead, limits the surgeon to securing the fastener into the calcaneus (the heel bone). Such systems also fail to provide the option of inserting fasteners in multiple axes to provide a more stable fixation system.

Moreover, fusion systems typically include one or more fasteners that engage only one foot bone in use. The fasteners do not cross articulating surfaces. It would be advantageous to provide a system that allows one or more fasteners to cross one or more articulating surfaces of the bones in the foot in order to provide more stability.

Another disadvantage of some fusion systems is that they do not provide nails with reinforced distal portions. If the nail is the same diameter throughout its length, but there are fastener holes in the distal portion, the implant may be weaker at that portion due to increased stresses from the patient’s weight. Thus, there is a need for a fusion system that provides greater rigidity and stability in use.

Accordingly, it would be advantageous to provide a nail and fastener assembly that addresses many of the problems that have not been solved by currently-available systems.

SUMMARY

The present invention comprehends various embodiments of nail and fastener assemblies, which may be employed, among other things, for use in providing a stable construct for optimal fixation of the hindfoot. It also comprehends various methods for implanting the nail and fastener assemblies.

Because bone quality is typically poor in patients who are candidates for this procedure, it is beneficial for a system to include a nail that provides additional fixation to hold the fasteners, which may be screws, pins, partially threaded screws, fasteners having a surface with threads or blades of various pitches, shapes, and rotations about the fastener, helical blades, bolts, or any other structure capable of holding and/or engaging bone, in a fixed position. It is also beneficial for a system to provide the option of stabilizing various articulating surfaces of the foot.

Accordingly, certain embodiments of the present invention provide fusion systems with fixation features between the nail and fastener that secure the fastener into the nail. Other embodiments provide a fusion system with one or more openings of the nail that receive fasteners at various angles, allowing one or more fastener to cross one or more articulating surfaces of the foot to provide for multi-planar and multi-axial implantation of the fasteners. Certain structures provide a fusion system with a fastener that crosses one or more of the talo-calcaneal and the calcaneo-cuboid articulating surfaces. Other embodiments combine these features or aspects of them.

One structure according to certain embodiments of the invention includes a hindfoot nail with a threaded fastener-receiving hole. Other structures include angled fastener-receiving bores, and further structures include assemblies adapted to fuse articulating surfaces of a patient’s foot. Methods of the invention provide methods for at least partially fusing certain bones of the patient’s hindfoot.

Certain devices of the present invention accomplish these results in a number of ways, some of which are discussed in detail below, with reference to the drawings.

BRIEF DESCRIPTION OF THE DRAWINGS

FIG. 1 shows a dorsal view of the anatomy of the foot.

FIG. 2 shows a side view of a foot having an implanted nail according to one embodiment of the invention.

FIG. 3 shows a perspective view of one embodiment of a nail and fastener assembly.

FIG. 3A shows a perspective hind view of a foot having an implanted nail and fastener assembly according to another embodiment of the invention.

FIG. 4 shows a side view of a nail according to one embodiment of the invention.

FIG. 4A shows a cross-sectional view of the nail of FIG. 4.

FIG. 5 shows another cross-sectional view of the nail of FIG. 4.

FIG. 6 shows a cross-sectional schematic view of the threaded angled bores of the nail of FIG. 4 showing fasteners (in phantom) inserted.

DETAILED DESCRIPTION OF THE DRAWINGS

Anatomy of the Foot and Ankle:

There are twenty-six bones in the human foot **10**, shown in FIGS. 1 and 2. There are seven tarsal bones: the bone that forms the heel is the calcaneus **12**; the talus **14** connects to and supports the tibia **30** (shown in FIG. 2) at the ankle. The five other tarsal bones are the navicular **16**, the cuboid **18**, and three cuneiforms **20**, which form the middle of the foot. Next, five metatarsals **22** form the lower portion of the instep of the foot. The metatarsals **22** radiate out to the phalanges **24**, which are the toe bones.

Of the tarsal bones, the talus **14** and the calcaneus **12** are the largest and are adjacent to each other. Also adjacent to the calcaneus **12** is the cuboid **18**. The calcaneus **12** and the talus **14** define an articulating surface **40** between the two bones (the talo-calcaneal articulating surface), and the calcaneus **12** and the cuboid **18** also define an articulating surface **42** (the calcaneo-cuboid articulating surface). Some or all of these, or combinations of them, are the foot bones and articulating surfaces that can be of particular interest to certain embodiments of the present invention.

Fusion System:

FIGS. 3 and 3A each show a fusion assembly **110** according to embodiments of the invention. Assembly **110** features a nail **112** and one or more fasteners **150**. In FIG. 3, some fasteners **150** are shown as partially threaded and partially smooth or fully threaded. In FIG. 3A, all fasteners **150** are shown having threads **152**. In short, a surgeon may choose to use a combination of any type of fasteners.

As shown in FIG. 2, nail **112** is adapted to be implanted into a patient's tibial canal. The fasteners **150** are adapted to be inserted through and received by the nail **112** and secure to particular bones of the foot. Different nails **112** are typically provided for the left and right sides of a patient's body to account for differing angles.

As shown in FIG. 4, nail **112** has a distal portion **114** and a proximal portion **116**. As best seen in FIGS. 2 and 3A, part of the proximal portion engages the tibia and part of the distal portion engages the calcaneus. Nail **112**, as is the case with other components of embodiments disclosed herein, can be formed of Titanium, Titanium alloys, Surgical Steel alloys, or other desired material. Distal portion **114** is shown having a greater outer diameter relative to the proximal portion **116** and may be considered, if desired, also to include a frustoconical transition segment between the portion with the greater outer diameter and the smaller outer diameter. How-

ever, distal portion **114** need not necessarily have a greater outer diameter than other portions of the nail **112**.

Nail **112** can be also cannulated, if desired. One form of such cannulation is shown in FIGS. 4-5 and can be accomplished by gundrilling or other appropriate techniques. Such cannulation enhances the ability of the nail **112** to be inserted using a closed surgical procedure, such as over a guide wire or rod. Cannulation in the distal portion **114** or portions of it, can be of greater diameter than cannulation in the proximal portion **116** or portions of it, as desired.

At the distal portion **114** is a driving end **118** that has an instrument-receiving portion **120**. Instrument-receiving portion **120** may include any type of connecting portion, such as a threaded bore **119** (shown in FIG. 5) that is adapted to receive and fasten to implantation instruments. Instrument-receiving portion **120** may also have an optional keyway **121** (shown in FIG. 6) that can provide additional stabilization with respect to implantation instruments. Other options for connecting the instrument-receiving portion **120** to implantation instruments may be a ball and detent mechanism, a dovetail and slot configuration, a lock and key configuration, or any other stable locking mechanism.

Because distal portion **114** of nail **112** (which again may, if desired, contain some or all of the frustoconical transition shown in FIGS. 4-5) may include one or more angled fastener holes **122**, **130**, distal portion **114** may be provided with an outer diameter that is larger than the diameter at proximal portion **116**. In the particular embodiment shown in FIGS. 4-5, the greater outer diameter can in some ways be considered to provide favorable properties such as any or all of increased resistance to bending, rigidity, strength, stability, durability and enhanced reception and/or retention of fasteners.

One aspect of embodiments of the present invention is that one or more fasteners are received by and secured to a nail, as well as being secured to the patient's bone. See, e.g., FIG. 3A. One structure used to accomplish the securing of the fastener to the nail can be a threaded bore and threaded fastener combination. In this example, the nail can have a threaded bore **128** and the fastener can have corresponding threads **152** at or near the portion received by the nail.

In the specific embodiment shown in FIG. 3A, the fastener is a threaded screw **150**. Threads **152** may be provided in any number of shapes (e.g., trapezoidal teeth, triangular teeth, square teeth), pitches, and rotations (e.g., tightly wound around fastener or "loosely" wound such that there is a greater distance between each thread). The screw threads and the threads of the nail need not have the same shape, pitch, or rotation, although they typically will.

In an alternate embodiment (not shown), the fastener is a partially threaded screw. Again, the threads may be provided in any number of shapes, pitches, and rotations. In this example, the threads are preferably located at or near the portion where the threads are secured into nail to prevent their migration.

In a further embodiment, the fastener has a series of cutting edges that engage a patient's bone. Cutting edges may be cutting blades, helical blades, spikes, or any other structure capable of holding and/or engaging bone. Cutting edges may cover all or just a portion of fastener. Alternatively, fastener may feature a bolt, a moly bolt, a tension spring, or any other structure capable of holding and/or engaging bone.

In use, the threaded bore **128** is adapted to receive and secure a corresponding structure on fastener with respect to nail **112**, as well as allow fastener to engage with bone. One or more openings in the nail **112** may be provided as threaded bores. It is also possible to provide a nail **112** having a com-

combination of threaded and non-threaded bores (the non-threaded bore structure is described below). It is also possible to provide openings in the nail that are partially threaded and partially non-threaded.

One optional feature that may be provided with assembly **110** is an insert or bushing (not shown) to prevent rotation of the fastener. See pending S&N application Ser. No. 10/999, 572, filed Nov. 30, 2004 and titled "Humeral Nail," the entire contents of which are hereby incorporated by this reference. This feature may provide a function similar to fastener anchors that can be used to hang a picture on a wall, i.e., the insert interferes with the rotation of the fastener in the nail and can prevent it from wobbling or threading out, without interfering with the ability of the fastener to insert into the nail at a range of angles. The insert may be used in connection with a threaded or non-threaded bore. It may be secured with respect to nail by the threads, by a rib and locking ring configuration, by injecting a biologic or bone cement through the cannulation as each fastener is inserted, by an interference fit, or any other securing means.

A further aspect of some embodiments of the present invention is that fusion of the hindfoot can be established by connecting and stabilizing certain articulating surfaces of the foot. In one specific embodiment, the talus **14** and the calcaneus **12** are connected to one another by a fastener that crosses the talo-calcaneal articulating surface when implanted. In another specific embodiment, the cuboid **18** and the calcaneus **12** are connected to one another by a fastener that crosses the calcaneo-cuboid articulating surface when implanted. This may be done by specifically targeting these bones using an assembly **110** with angled holes or bores according to one embodiment of the present invention, as shown in FIG. 3A. This particular embodiment provides for multi-planar (and if desired, multi-axial) fixation. The nail may also be adapted to be secured to the tibia **30** for additional stability.

One particularly beneficial aspect of providing angled fastener holes **122**, **130** is that they are provided such that any fastener received therein can target specific bones. In one structure according to certain embodiments of the invention, the fasteners are pin-like or substantially smooth. In another structure, the fasteners may have a portion that is threaded (or that contains cutting blades, helically shaped structures having any angle relative to the fastener axis, or other fastening structure to engage bone) that are adapted to secure to a patient's bone, and a portion that is at least partially smooth. These fasteners may be referred to as compression screws, an example of which is shown in FIG. 3.

Compression screws have a portion adapted to attach to a patient's bone, as well as an at least partially smooth portion that articulates with the nail for sliding compression. The at least partially smooth surface is allowed to "slide" within the nail, such that when the patient applies pressure to the implant (for example, if the implant is a weight-bearing implant in the foot, the patient applies pressure when stepping down), the fastener compresses the bones together. The bone fragments are allowed to slide and bear on each other for better healing and fusion of the site.

In certain embodiments, the portion that cooperates with a patient's bone is adapted to cooperate with the calcaneus, and in other embodiments, the portion that cooperates with a patient's bone is adapted to cross one or more articulating surfaces of the foot.

Alternatively, angled fastener holes may have internal threads **128**. In use, internal threads **128** of nail **112** cooperate with fastener threads **152** of fasteners **150** to secure the fasteners into the nail **112**, as well as into the patient's bone. For ease of reference, fasteners will be referred to as fasteners **150**

(which are shown as threaded screws) throughout the remainder of this application, although it is understood that fasteners may take any of the above-described forms, such as compression screws, pins, partially threaded screws, and so forth. See e.g. FIG. 3.

In embodiments in which the fastener is adapted to cross articulating surfaces, fastener holes **122**, **130** are provided at optimal angles that allow the surgeon to achieve fastener attachment into particular bones of the foot, such as the calcaneus **12**, the talus **14**, and the cuboid **18**. Angled fastener holes **122**, **130** are oriented so that fasteners **150** can be inserted into the nail **112** and cross one or more of the articulating surfaces **40** and **42** of the foot bones.

For example, consider nail **112** having a central longitudinal axis **124** as shown in FIGS. 4-5. At least one angled fastener hole **122** is positioned at an angle θ that is between about 45° and about 135° off of the central longitudinal axis **124**. (In other words, when a fastener is inserted through the hole **122**, the fastener itself creates an axis **160** that forms an angle of between about 45° and about 135° with the central longitudinal axis **124**, as shown in FIG. 4A.) In a particular embodiment, at least one angled fastener hole **122** is positioned at an angle between about 65° and about 115° off of the central longitudinal axis **124**. In an even more preferred embodiment, the angled fastener hole **122** is positioned at an angle between about 80° and about 90° off of the central longitudinal axis **124**, and most preferably, at about 85° off of the central longitudinal axis **124**.

Central longitudinal axis **124** also intersects a plurality of planes. One cross-section defined by central longitudinal axis **124** is central plane **125**, which is the plane in the page of the paper. This cross-sectional view is shown in FIG. 4A. In addition to its angled orientation with respect to central longitudinal axis **124**, angled fastener hole **122** may also be disposed at an angle that is rotated off of the plane **125** of the paper. (In other words, when a fastener is inserted through hole **122**, the fastener forms a second plane that is not aligned with plane **125** and would either extend from or retreat into plane **125** of the paper.) In one embodiment, fastener **150** may either be rotated about $0-45^\circ$ into the plane **125** of the page or rotated about $0-45^\circ$ out of the plane **125** of the page. In one embodiment, angled fastener hole **122** is rotated about $2-30^\circ$ off of plane **125**. In a further embodiment, it is rotated about $5-15^\circ$ off of plane **125**, and is most preferably, about 10° off of plane **125**. (This angle may be in either the medial or the lateral direction.)

In certain embodiments, angled fastener hole **122** is adapted to receive a fastener that targets the cuboid **18** in use, or that at least partially traverses the calcaneo-cuboid articulating surface **42**, as shown in FIG. 3.

A second angled fastener hole **130** may also be positioned on the distal portion **114** of nail **112**. This angled fastener hole **130** may be positioned at an angle α that is between about 25° and about 135° off of the central longitudinal axis **124**, such that a fastener inserted therein forms axis **162**. In a particular embodiment, second angled fastener hole **130** is positioned at an angle between about 45° and about 115° off of the central longitudinal axis **124**. In an even more preferred embodiment, second angled fastener hole **130** is positioned at an angle between about 50° and about 75° off of the central longitudinal axis **124**, and most preferably, second angled fastener hole **130** is positioned at about 55° off of the central longitudinal axis **124**.

In addition to its angled orientation with respect to central longitudinal axis **124**, second angled fastener hole **130** may also be rotated at an angle off of plane **125**. For example, angled fastener hole **130** may be rotated about $0-45^\circ$ off of

plane **125**, as shown in FIG. **6**. In one embodiment, angled fastener hole **130** is rotated about 2-30° off of plane **125**. In a further embodiment, it is rotated about 5-15° off of plane **125**, and is most preferably, about 10° off of plane **125**. (Again, this angle may also be in either the medial or the lateral direction. It is preferred, although not required, that angled fastener hole **122** be about 10° in the opposite direction of angled fastener hole **130**.)

In certain embodiments, second angled fastener hole **130** is adapted to receive a fastener that targets the talus **14** in use, or that at least partially traverses the talo-calcaneal articulating surface **40**, as shown in FIG. **3**.

There may be provided a third fastener hole **132**, which also has internal threads **128**, but that may or may not be provided at an angle. Consider nail **112** with a horizontal axis **127** that is perpendicular to the central longitudinal axis **124** and that defines a horizontal plane perpendicular to plane **125** (i.e., extending out from the page). FIG. **5** shows the nail of FIG. **4** cut through a plane that extends perpendicular to plane **125** and then rotated 90° to illustrate the threaded bore of fastener hole **132**.

In one embodiment, fastener hole **132** is disposed through distal portion **114** of nail **112** in the horizontal plane, give or take a few degrees. When fastener **150** is inserted through fastener hole **132**, the fastener creates an axis that forms an angle of between about 80°-100°, and preferably about 90° with the central longitudinal axis **124**, as shown in FIG. **3**. In certain embodiments, the third fastener hole **132** is a transverse fastener that targets the calcaneus **12**.

In use, a surgeon may choose to use one or more of threaded holes **122**, **130**, **132**, or any combination thereof. For example, a surgeon may only need to use hole **122**. In other cases, for example, if more stability is needed, the surgeon will also use **130** and/or hole **132**. Alternatively, a surgeon may only use hole **132**, but again, may use additional holes for additional stability.

Fasteners **150** may be provided in any number of lengths, although it is preferable that at least one fastener be provided in a length that allows it cross one of more of articulating surfaces **40** and **42**. Exemplary fastener lengths may be between 50 to 110 mm.

There may also be one or more static locking holes **136** or a dynamic compression slots **137** at the proximal portion **116** of nail **112**. These openings **136**, **137** are provided for rotational stability of assembly **110** and are typically not threaded or angled, although they can be angled and/or threaded as desired. Although the present inventors believe that it would not be good surgical practice to fix the fasteners to the holes in the proximal portion of nail **112** by threads because the nail **112** should not be overconstrained, it is understood that there could be instances when such fixation would be desired, and threaded upper holes are considered within the scope of this invention.

The surgeon may choose between static or dynamic locking by placing a fastener, pin, or small nail through either a static hole **136** or dynamic slot **137** and into the tibia **30**. It is preferred that one of each opening **136**, **137** be provided in order to give the surgeon the most flexibility, although this is not required.

Method:

A surgeon first chooses the properly-sized nail **112**. (Nails are typically provided in 10-50 cm lengths.) The choice is based on the length of the ankle from the bottom of the calcaneus to a suitable fixation point on the tibia. In essence, the goal is to fuse the nail **112** with the calcaneus **12** and the

tibia **30** to immobilize the ankle joint. Typically, the surgeon will remove cartilage from the ankle to encourage the bones to fuse.

Although the surgery may be performed as a closed procedure (i.e., minimally invasive) and it is often preferable for it to be that way due to ease of healing, some surgeons may also wish to remove cartilage from between the bones prior to the procedure, which is often performed using open surgical techniques. In short, embodiments of the invention lend themselves to use during either type of procedure.

In one embodiment of the procedure, the surgeon makes an incision into the non-weight bearing part of the sole of the foot (i.e., the fatty tissue part of the heel) in line with the tibial planar axis. The surgeon may insert a guide wire into the tibial canal to assist reaming and the placement of nail **112**. Once the canal has been reamed to an appropriate diameter and depth, the nail **112** is driven into the center (marrow) portion of the tibia **30**, typically using one or more of the instrument-receiving portion **120** or the keyway **121** for securing the implant instrumentation. Preferably, the surgeon uses a C-arm or other image intensifier to insert the nail **112** over a guide wire or rod in a closed surgical procedure as well as to insert the related fasteners.

Instrumentation may also be used to hold and guide drill bits to prepare other bones for receiving fasteners. Similar instrumentation may be used to hold and place a fastener. The fastener can be rotated into place, hammered, or otherwise inserted as desired. In some instances, guide wires may be used to place the fastener as well.

If the surgeon plans to aid the fusion process by inserting a fastener that will cross the calcaneo-cuboid articulating surface **42**, the surgeon will insert the fastener through the posterior aspect of the calcaneus, through the opening in the nail, and into the cuboid to target that junction. In the embodiment shown, the surgeon would place fastener **150** into the most inferior angled fastener hole **122**. The threads of fastener **150** cooperate with internal threads **128**, as well as achieve purchase into the calcaneus **12** and cuboid **18**. Alternatively, a compression screw, a pin, an at least partially threaded screw, or other embodiments may be used. In any event, this fastener will typically have a relatively "shallow" angle, being inserted at the calcaneus and at least partially crossing the calcaneo-cuboid articulating surface **42**.

Once the first fastener is inserted, the surgeon may gently tap the driving end **118** of the nail **112** to achieve compression of the ankle. If the surgeon plans to place a transverse fastener (in this case, a fastener that will cooperate with the calcaneus **12**), the fastener may be inserted through third fastener hole **132** in either the medial to lateral or lateral to medial direction. Even though this fastener is not necessarily strictly horizontal, it tends to be the most horizontally-located of the fasteners.

Next, if the surgeon plans to aid the fusion process by inserting a fastener that will cross the talo-calcaneal articulating surface **40**, the surgeon will insert a fastener into the posterior of the calcaneus, through an opening of the nail, and into the talus to target that junction. In the embodiment shown, the surgeon would place fastener **150** into the superior angled fastener hole **130**. The threads of fastener **150** will cooperate with internal threads **128**, as well as achieve purchase into the calcaneus **12** and talus **14**. Alternatively, a compression screw, a pin, an at least partially threaded screw, or other embodiments may be used. In any event, this fastener tends to be the most steeply angled of the three (assuming that all three fasteners are used). Assuming the patient's foot is standing on a horizontal surface, this fastener will have a

relatively steep “upward” angle to at least partially cross the talo-calcaneal articulating surface **40**.

This procedure has been described as if the surgeon is using three fasteners, although it should be understood that a surgeon may choose to use fewer or more fasteners and that nails according to structures of this invention may also have fewer or more fastener-receiving bores.

After the nail and junction fasteners have been properly placed in the patient’s foot, the surgeon will secure the nail **112** with a fastener at the proximal portion **116** of the nail **112**. The surgeon may choose between static or dynamic locking by placing the fastener through either a static hole **136** or a dynamic slot **137** in nail **112**.

Changes and modifications, additions and deletions may be made to the structures and methods recited above and shown in the drawings without departing from the scope or spirit of the invention and the following claims.

What is claimed is:

[1. A method for at least partially fusing a patient’s calcaneo-cuboid articulating surface and talo-calcaneal articulating surface in a hindfoot fusion process, the method comprising:

- (a) providing a nail having a proximal portion and a distal portion, the distal portion having a first angled fastener-receiving hole and a second angled fastener-receiving hole;
- (b) providing a first fastener adapted to be received in the first angled fastener-receiving hole and a second fastener adapted to be received in the second angled fastener-receiving hole;
- (c) implanting the nail into a patient’s tibial canal;
- (d) inserting the first fastener through the first angled fastener-receiving hole in the nail, such that the first fastener at least partially crosses the patient’s calcaneo-cuboid articulating surface; and
- (e) inserting the second fastener through the second angled fastener-receiving hole in the nail, such that the second fastener at least partially crosses the talo-calcaneal articulating surface.]

[2. The method of claim **1**, wherein at least one of the first fastener-receiving hole and the second fastener-receiving hole is at least partially threaded.]

[3. A method of ankle arthrodesis on a patient, the patient having a tibia, a cuboid, a talus, and a calcaneus, the tibia having a tibial canal, the method comprising the steps of:

- a. selecting a properly sized nail;
- b. reaming the tibial canal;
- c. inserting the nail into the tibial canal;
- d. inserting a first fastener into the calcaneus, through the nail, and into the cuboid; and
- e. inserting a second fastener into the calcaneus, through the nail, and into the talus, wherein a tip portion of the second fastener achieves purchase within the talus.]

[4. The method of claim **3**, further comprising the step of removing cartilage from one or more bones.]

[5. The method of claim **3**, further comprising the step of incising a non-weight bearing part of a sole of the patient’s foot.]

[6. The method of claim **3**, further comprising the step of inserting a guide wire into the tibial canal.]

[7. The method of claim **3**, further comprising the step of inserting a transverse fastener into the calcaneus and the nail.]

8. A nail for ankle arthrodesis on a patient, comprising: a shaft having a proximal portion configured for receipt within a tibial canal of the patient’s tibia, a distal portion configured to engage the patient’s calcaneus, and a

central longitudinal axis extending therebetween, the proximal portion of the shaft being straight, the shaft defining three, non-intersecting holes in the distal portion, each of the holes configured to receive a fastener extending through the shaft from a first outer side to an opposing second outer side of the shaft such that the fastener can have bone purchase on both sides of the shaft, at least two of the holes having through axes offset and non-perpendicular to the central longitudinal axis, the through axes of the at least two of the holes being offset from perpendicular to the central longitudinal axis in the same proximal/distal direction, and the third hole being positioned between the at least two of the holes relative to the longitudinal axis.

9. The nail of claim **8**, wherein the shaft further defines a hole and a slot in the proximal portion of the shaft.

10. The nail of claim **8** wherein the shaft is straight.

11. The nail of claim **8** wherein the axes of the at least two of the holes are non-parallel.

12. The nail of claim **11** wherein the axes of the at least two of the holes are constrained to non-parallel planes.

13. The nail of claim **8** wherein the axis of one of the at least two holes is orientated to direct a fastener toward the talus, and the axis of the other of the at least two holes is orientated to direct a fastener toward the cuboid.

14. The nail of claim **8** wherein the distal portion has a greater outer diameter relative to the proximal portion.

15. The nail of claim **14** further including a frusto-conical transition segment between the distal portion and the proximal portion.

16. The nail of claim **8** wherein the shaft defines a through lumen along the central longitudinal axis.

17. The nail of claim **8** wherein the at least two of the holes are threaded.

18. The nail of claim **8** further comprising fasteners received by the at least two of the holes, wherein the fasteners are threaded.

19. The nail of claim **8** further comprising fasteners received by the at least two of the holes, wherein one of the fasteners is provided in a length that allows the fastener to extend through the nail and cross the calcaneus/talus articulating surface.

20. The nail of claim **19** wherein the one of the fasteners length is 50 to 100 mm.

21. The nail of claim **8** further comprising fasteners received by the at least two of the holes, wherein one of the fasteners is provided in a length that allows the fastener to extend through the nail and cross the calcaneus/cuboid articulating surface.

22. The nail of claim **21** wherein the one of the fasteners length is 50 to 100 mm.

23. The nail of claim **8** wherein the hole axes are oriented about 10-30 degrees circumferentially offset about the nail.

24. The nail of claim **23** wherein the hole axes are oriented about 20 degrees circumferentially offset about the nail.

25. The nail of claim **8** wherein a more proximal hole of the at least two of the holes comprises an offset to the central longitudinal axis of an angle, alpha, between 50 and 75 degrees.

26. The nail of claim **25** wherein the angle, alpha, comprises 55 degrees.

27. The nail of claim **8** wherein a more distal hole of the at least two of the holes comprises an offset to the central longitudinal axis of an angle, theta, between 80 and 90 degrees.

28. The nail of claim **27** wherein the angle, theta, comprises 85 degrees.

11

29. A nail for ankle arthrodesis on a patient, comprising:
 a shaft having a proximal portion configured for receipt
 within a tibial canal of the patient's tibia, a distal por-
 tion configured to engage the patient's calcaneus, and a
 central longitudinal axis extending therebetween, 5
 the shaft defining three, non-intersecting holes in the distal
 portion, each of the holes configured to receive a fas-
 tener extending through the shaft from a first outer side
 to an opposing second outer side of the shaft such that
 the fastener can have bone purchase on both sides of the 10
 shaft, at least two of the holes having through axes offset
 and non-perpendicular to the central longitudinal axis,
 the through axes of the at least two of the holes being
 offset from perpendicular to the central longitudinal axis 15
 in the same proximal/distal direction, and the third hole
 being positioned between the at least two of the holes
 relative to the longitudinal axis,
 the shaft defining a hole and an elongated slot in the proxi-
 mal portion of the shaft.

12

30. A nail for ankle arthrodesis on a patient, comprising:
 a shaft having a proximal portion configured for receipt
 within a tibial canal of the patient's tibia, a distal por-
 tion configured to engage the patient's calcaneus, and a
 central longitudinal axis extending therebetween,
 the shaft defining a through lumen extending along the
 direction of the central longitudinal axis,
 the shaft defining three, non-intersecting holes in the distal
 portion, each of the holes configured to receive a fas-
 tener extending through the shaft from a first outer side
 to an opposing second outer side of the shaft such that
 the fastener can have bone purchase on both sides of the
 shaft, at least two of the holes having through axes offset
 and non-perpendicular to the central longitudinal axis,
 the through axes of the at least two of the holes being
 offset from perpendicular to the central longitudinal axis
 in the same proximal/distal direction, and the third hole
 being positioned between the at least two of the holes
 relative to the longitudinal axis.

* * * * *