

[72] Inventor **Anton Pfeuffer**
 301 E. 78th St., New York, New York 10021
 [21] Appl. No. **707,512**
 [22] Filed **Feb. 23, 1968**
 [45] Patented **Nov. 24, 1970**

2,433,684	12/1947	Damond.....	222/196
2,561,975	7/1951	Daniel.....	222/196
2,677,465	5/1954	Meyer.....	222/189
2,706,072	4/1955	Furno.....	222/196
2,767,886	10/1956	Jenkins.....	222/189
3,003,667	10/1961	Jonsson.....	222/199
3,012,697	12/1961	Rouse.....	222/189
3,305,142	2/1967	Caldwell.....	222/195
3,346,917	10/1967	Lennox.....	222/203

[54] **APPARATUS FOR SUPPLYING DRY SOLIDS TO LIQUIDS**
 5 Claims, 6 Drawing Figs.

Primary Examiner—Robert B. Reeves
 Attorney—Nolte and Nolte

[52] U.S. Cl..... 222/195,
 222/200
 [51] Int. Cl..... B65g 3/12
 [50] Field of Search..... 222/196,
 195, 200, 202, 161, 199, 133, 145, 198, 136, 181,
 333

[56] **References Cited**
UNITED STATES PATENTS
 2,689,597 9/1954 Kinnear..... 222/199X
 3,123,256 3/1964 Smith et al..... 222/333X
 1,611,388 12/1926 Stewart..... 222/196
 2,170,258 8/1939 Borch..... 222/196

ABSTRACT: A screen of determined mesh is shock mounted and vibrated horizontally by a motor coupled to and supported by the screen at the opening of a dry solid material supply source. A substantially annular member of gas porous material of substantially frustoconical configuration is positioned at the bottom of the supply source in abutment with the wall thereof in a manner whereby it provides an enclosed space between the member and the bottom of the source. Gas under pressure is supplied to the space provided under the annular member. A funnel supported by the annular member directs the dry solid material to the center of the screen.

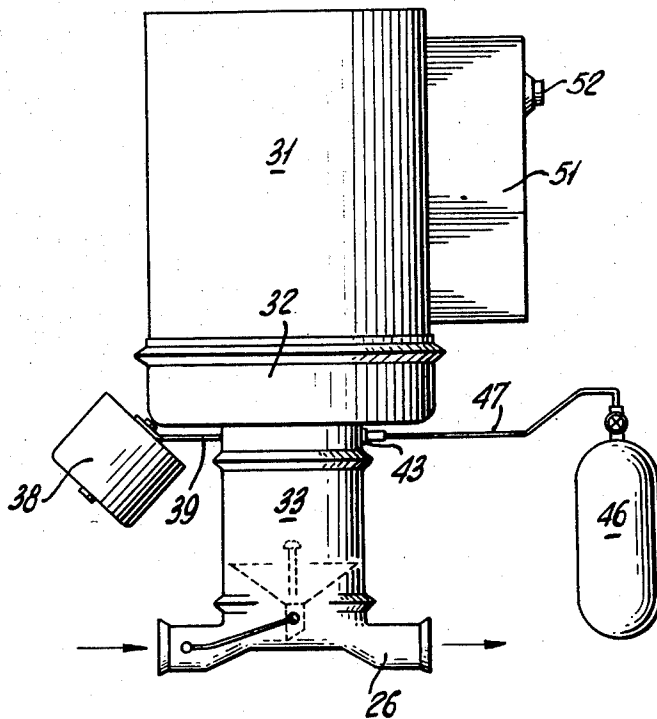

Fig. 1.

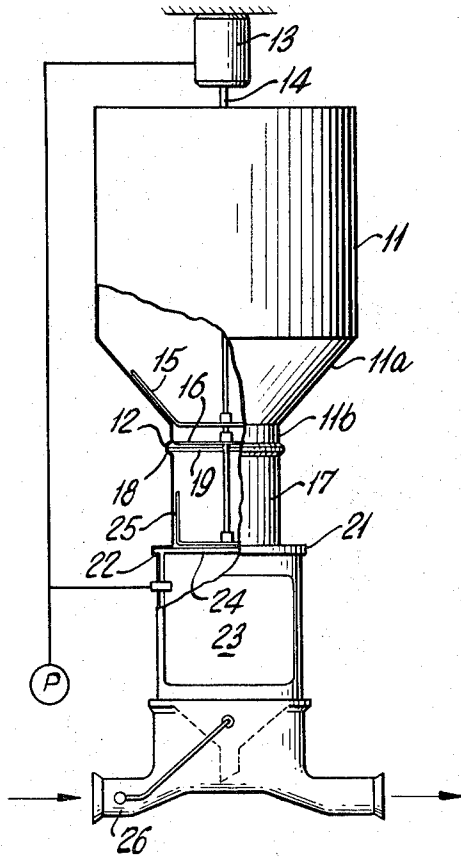
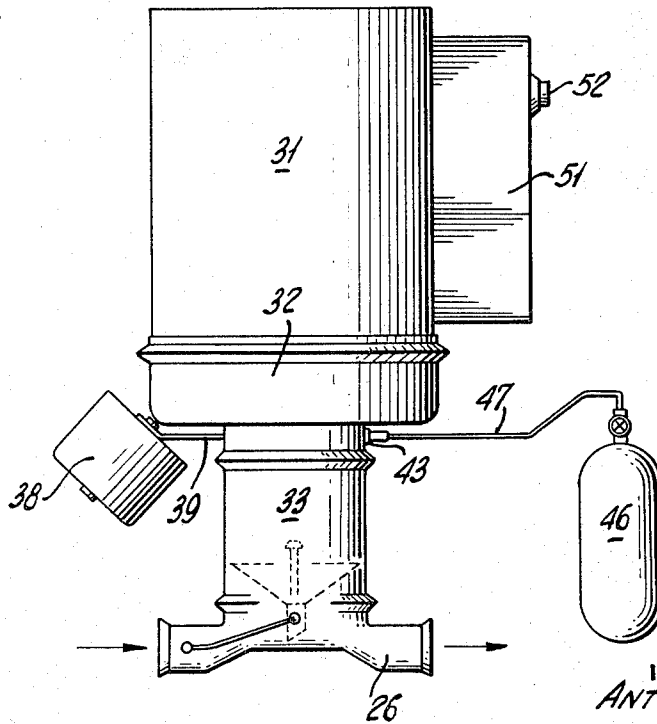
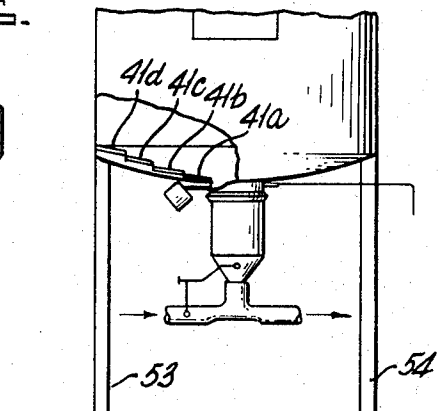
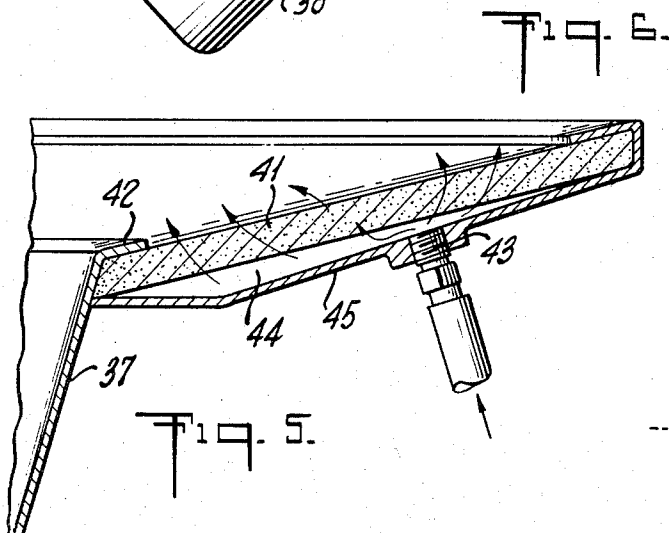
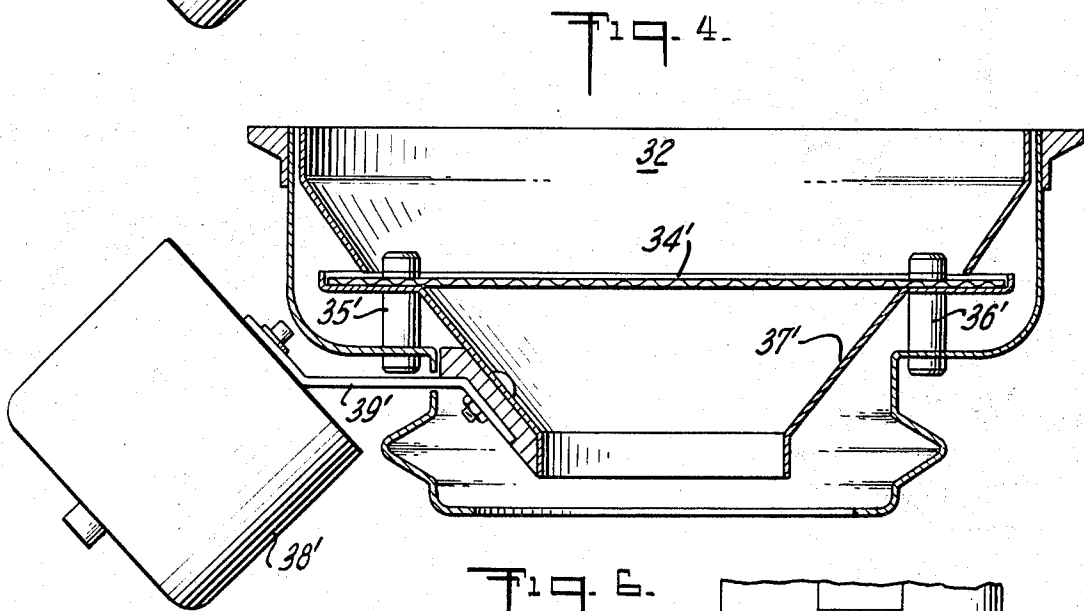
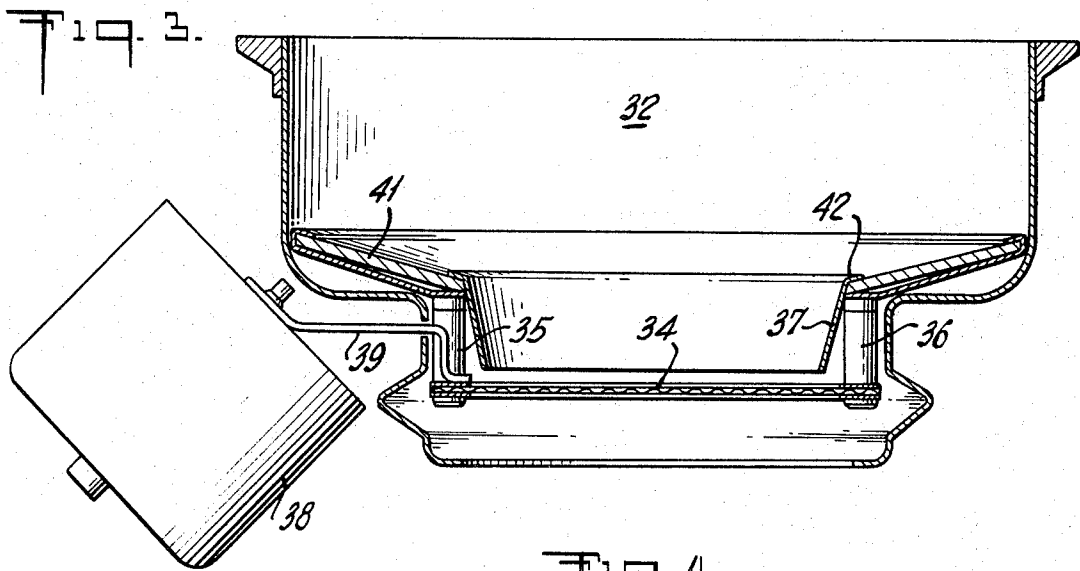

Fig. 2.



INVENTOR
ANTON PFEUFFER
BY
Grolte & Grolte
ATTORNEYS



INVENTOR
ANTON PFEUFFER

BY
Nolle & Nolle
ATTORNEYS

APPARATUS FOR SUPPLYING DRY SOLIDS TO LIQUIDS

DESCRIPTION OF THE INVENTION

The present invention relates to an instant feeder or apparatus for supplying dry solids to liquids. More particularly, the invention relates to apparatus which rapidly, accurately, reliably and continuously mixes and feeds dry solids to liquids.

The present invention relates to an improvement in the apparatus disclosed in my U.S. Pat. application Ser. No. 521,132, filed Jan. 17, 1966, now U.S. Pat. No. 3,373,901 which in turn is an improvement in the apparatus disclosed in my U.S. Pat. No. 3,039,655, issued June 19, 1962.

My U.S. Pat. No. 3,039,655 discloses apparatus which solves the problem of adding measured amounts of a filter-aid material such as, for example, infusorial earth, to a fluid flowing in a pipeline and carried by said pipeline to a filter. The apparatus disclosed in U.S. Pat. No. 3,039,655 operates on the principle that an increase in the effective surface area of any given feed or supply device results in an increase in the capacity of the device for supplying filter-aid to a filtration system. Thus, a plurality of cylindrical containers are provided which terminate at a funnel-shaped base portion of the feed device. Each of the containers contains a quantity of infusorial earth or the like. The containers have associated washdown funnels located at the lower end thereof to provide an uninterrupted movement of the dry solids. In apparatus of this type, it is a basic requirement that a gaseous or liquid medium be introduced at different places in an associated hopper to prevent bridging of the dry solids.

My U.S. Pat. application No. 521,132 discloses apparatus which comprises a hopper and a mixing chamber coupled to the pipeline through which the liquid flows. A metering device is interchangeably disposed between the hopper and the mixing chamber for providing a controlled even flow of solids. The metering device is separated from the hopper and the mixing chamber by perforated plates. The perforated plates are removably positioned between the hopper and the metering device and between the metering device and the mixing chamber. A motor-driven shaft extends through the hopper into the metering device and has stirrers mounted thereon and rotatable therewith. Each of the perforated plates has a stirrer associated therewith.

The principal object of the present invention is to provide a new and improved apparatus for supplying dry solids to liquids.

An object of the present invention is to provide apparatus for supplying dry solids to liquids in which the supply of dry solids is adjustable.

An object of the present invention is to provide apparatus for supplying dry solids to liquids which combines the screen and fluidizer assembly thereby providing a considerable saving in space by eliminating any special configuration of the hopper.

An object of the present invention is to provide apparatus for supplying solids to liquids which has removable screens to enable the supply of any type of free-flowing or nonfree-flowing solids.

Another object of the present invention is to provide apparatus for supplying dry solids with accuracy, uniformity and economy.

In accordance with the present invention, apparatus for supplying a dry solid to a receiving source in a smooth and uninterrupted flow comprises a material supply having an opening for supplying a dry solid material. Even flow-rate apparatus at the opening of the material supply provides dry solid material from the material supply at an even flow-rate and comprises a screen of determined mesh and a vibrator for vibrating the screen. A mixer couples the even flow-rate apparatus to the receiving source and supplies dry solid material passed by the screen to the receiving source.

The flow-rate apparatus comprises a screen of determined mesh, shock mounts comprising rubber shock members

mounting the screen at the opening of the material supply and a vibrator coupled to the screen for vibrating the screen. The vibrator comprises a motor coupled to and supported by the screen.

The material supply has a wall, a bottom closing the wall and an opening formed through the bottom for supplying dry solid material. A fluidizer positioned at the bottom of the material supply and abutting the wall of the material supply moves dry solid material accumulated around the opening in the bottom into the opening. The fluidizer comprises a substantially annular member of gas porous material of substantially frustoconical configuration positioned to provide an enclosed space between the annular member and the bottom of the material supply and a gas supply furnishing gas under pressure to said space.

A funnel supported by the annular member directs the dry solid material to the center of the screen. The funnel may alternatively, be affixed to the screen and mounted on the rubber shock members beneath the screen and to direct dry solid material passing through the screen to the central area of the mixer.

In another embodiment of the invention, the fluidizer comprises a plurality of substantially annular members of gas porous material each substantially frustoconical in configuration positioned in stepped relation relative to each other and positioned to provide an enclosed space between the assembly of annular members and the bottom of the material supply and a gas supply furnishing gas under pressure to said space.

In order that the present invention may be readily carried into effect, it will now be described with reference to the accompanying drawings, wherein:

FIG. 1 is a cutaway view of an embodiment of apparatus of the type disclosed in my U.S. Pat. application Ser. No. 521,132;

FIG. 2 is a view of an embodiment of the apparatus of the present invention for supplying dry solids to liquids;

FIG. 3 is a view, partly in section, of an embodiment of the combined fluidizer and vibratory assembly of the apparatus of the present invention;

FIG. 4 is a view, partly in section, of an embodiment of the vibratory assembly of the apparatus of the present invention;

FIG. 5 is a sectional view, on an enlarged scale, of part of the fluidizer of the apparatus of the embodiment of FIG. 3 of the present invention; and

FIG. 6 is a cutaway view of another embodiment of the apparatus of the present invention.

In FIG. 1, dry solids such as, for example, pulverized, granular, free-flowing or nonfree-flowing types are fed into a hopper 11 either directly or by any suitable means (not shown) from a supply source. The hopper 11 has a tapering funnel portion 11a and a cylindrical throat portion 11b. A flange 12 is integrally formed with the throat portion 11b of the hopper 11 around the open base thereof. The hopper 11 is affixed to the remainder of the apparatus.

A gear motor 13 is mounted by any suitable means (not shown) above the hopper 11 and rotates a shaft 14 at a determined angular velocity. A first stirrer 15 is affixed to the shaft 14 at the bottom of the hopper 11 at the level where the tapered funnel portion 11a and the cylindrical throat portion 11b meet. A second stirrer 16 is affixed to the shaft 14 at the bottom of the hopper 11 at the level of the lower open base of the cylindrical throat portion 11b thereof.

A metering device 17 has an integrally formed flange 18 around the upper base thereof which cooperates with the flange 12 of the hopper 11 and is substantially coaxially positioned with the hopper. A substantially continuous cylindrical passageway is thus provided by the hopper 11 and the metering device 17. A first perforated plate 19 is mounted between the throat portion 11b of the hopper 11 and the metering device 17 and is maintained in position by the flanges 12 and 18.

The first perforated plate 19 has a plurality of apertures formed therethrough amounting to 10 to 65 percent of the

total area of said plate. The apertures are of conical configuration and the first plate 19 is positioned with the smaller opening of each aperture facing upward toward the hopper 11. Sharp cutting edges are formed in the first plate 19 around the smaller openings of the apertures formed through said plate.

The metering device 17 is preferably affixed to the hopper 11 by clamps (not shown) which are readily and facily removable and permit facile and rapid exchange or replacement of the first perforated plate 19, as well as rapid and facile assembly and disassembly of said device and said hopper. The first perforated plate 19 may thus be selected in accordance with the requirement of a particular flow-rate associated with a particular type of dry solid to be utilized. The hopper 11 and metering device 17 may comprise plastic, cast iron, copper, brass, stainless steel, or other suitable material. The first perforated plate 19 preferably comprises an abrasive-resistant material such as, for example, stainless steel, nylon or teflon.

The first stirrer 16 is positioned closely adjacent the first perforated plate 19, so that as soon as the apparatus commences operation said stirrer pushes a determined amount of solid material over the cutting edges around the opening of the apertures through said plate and moves the material through said apertures into the metering device 17. A flange 21 is integrally formed with the metering device 17 around the lower base thereof and cooperates with a flange 22 integrally formed with a mixing chamber 23 around the upper base thereof.

A second perforated plate 24 is mounted between the metering device 17 and the mixing chamber 23 and is maintained in position by the flanges 21 and 22 in the same manner that the first perforated plate is mounted and maintained by the flanges 12 and 18. The second perforated plate 24 has a plurality of apertures of conical configuration formed therethrough in the same manner as the first plate 19. The second plate 24 is positioned in the same manner as the first plate 19 with the smaller opening of each aperture facing upward toward the metering device 17. Sharp cutting edges are formed in the second plate 24 around the smaller openings of the apertures formed through said plate.

A third stirrer 25 is affixed to the shaft 14 at the bottom of the metering device 17 in a position closely adjacent the second perforated plate 24. The third stirrer 25 may be of substantially L-shaped configuration. The apertures through the first and second perforated plates 19 and 24 of a corresponding set are correlated with each other and with the angular velocity or speed of rotation of the shaft 14, so that dry solids at any level in the hopper 11 flow evenly to the mixing chamber 23. Thus, for example, a smaller percentage of apertures through the first plate 19 and a greater percentage of apertures through the second plate 24 for a particular requirement results, at a determined speed of rotation of the shaft 14, in an even flow-rate of a given solid to the mixing chamber 23.

The metering device 17 is preferably affixed to the mixing chamber 23 by clamps (not shown) which are readily and facily removable and permit facile and rapid exchange or replacement of the second perforated plate 24, as well as rapid and facile assembly and disassembly of said device and said chamber. In specific applications, a plurality of overflow openings (not shown) may be formed through a determined circumferential portion of the mixing chamber 23 to convey excessive solid material to the outside of said chamber. The overflow openings are particularly useful, for example, in feeding soap into a line.

In order to properly mix the dry solids with the fluid, the fluid in the mixing chamber 23 is maintained at a sufficient or suitable level by any suitable means such as, for example, that disclosed in U.S. Pat. application Ser. No. 521,132. The apparatus may be connected into a pipeline 26 by any suitable means such as, for example, an eductor type open feeder apparatus.

In FIG. 2, a hopper 31, a metering device 32 and a mixing chamber 33 may be removably affixed to each other in substantially coaxial relation, in the same manner as the counterparts of FIG. 1. The hopper 31, metering device 32 and mixing

chamber 33 function in the same manner as their counterparts of FIG. 1, dry material from the metering device 32 being supplied in the mixing chamber to liquid flowing through the pipeline 26.

In FIG. 3, a screen 34 is removably mounted on rubber shock members such as 35 and 36 between the bottom of the metering device 32 and the top of the mixing chamber 33. A funnel 37 is affixed in close proximity with the screen 34. A vibrator or motor 38 is affixed to the screen 34 by an arm 39. The motor 38 may be readily controlled in speed or frequency of vibration by any suitable means such as, for example, a variable resistor connected in its input (not shown) and having a manually adjustable knob or dial member (not shown).

The motor or vibrator 38, when energized, causes the screen 34 to vibrate at a frequency corresponding to that to which said motor is adjusted to operate. The solid material flow to the screen 34 is kept away from the edges of said screen by utilizing the funnel 37 which has a smaller outlet diameter than the screen diameter, so that the diameter of the supply area is smaller than that of said screen. This avoids any problems regarding sealing of the screen 34 around its periphery.

In FIG. 4 the stationary upper funnel 37' is utilized to direct the solid material through the screen 34'

and through a vibrating lower funnel 37'' into the central area of the mixing chamber 33 (FIG. 2). The screen 34' is removably mounted on the lower funnel 37' which is supported on the rubber shock members 35' and 36' in the bottom of the metering device 32, and is affixed to the funnel 37' at the opening of larger diameter of said funnel. The vibrator or motor 38' is affixed to the funnel 37' by the arm 39'.

The vibrator arrangements of FIGS. 3 and 4 are essentially the same and function in the same manner, although the embodiment of FIG. 3 is especially suitable for supply tanks with larger diameters and the embodiment of FIG. 4 is especially suitable for supply tanks with smaller diameters. The operating principle of the apparatus of the present invention is based upon the high bridging tendency of the infusorial earth or solid material. Thus, when the motor 38 and 38' is deenergized, the screen 34 and 34' does not vibrate and there is no flow of solid material therethrough. When the vibrator or motor 38 or 38' is energized, the screen 34 and 34' vibrates and solid material flows therethrough at a volume per unit time which is determined by the input adjustment of said motor and the screen mesh or size. The amount of solid material which flows through the screen 34 and 34' may vary, for example, from 6 to 900 ounces per hour, in accordance with the adjustment of the motor, the wire size or mesh of the screen, and the overall diameter of the screen.

In the embodiment of FIG. 3, the screen 34 is combined with a fluidizer, a portion of which is shown on a greater scale in FIG. 5. The fluidizer especially adapts the apparatus for use with a supply tank of greater diameter. In the embodiment of FIGS. 3 and 5, the fluidizer comprises a fluidizer ring 41 of annular substantially frustoconical or tapered configuration. The fluidizer ring 41 comprises any suitable gas porous material and is positioned at the bottom of the metering device 32 with its inner or smaller diameter periphery abutting the upper peripheral area of the funnel 37 and with its outer or larger diameter periphery abutting the substantially cylindrical wall of said metering device.

The upper or larger diameter periphery of the funnel 37 has an integrally formed lip or collar 42 extending radially therefrom and overlapping the adjacent inner peripheral portion of said funnel. As shown in FIG. 5, and not shown in FIG. 3 in order to preserve the clarity of illustration, a suitable gas such as, for example, carbon dioxide, is supplied under pressure, via an outlet nozzle 43, to an enclosed space 44 formed by the bottom of the fluidizer ring 41 and a member 45 of substantially the same configuration as said fluidizer ring but somewhat dished to form said space. As shown in FIG. 2, the gas may be supplied to the inlet nozzle 43 from a tank 46 via a gas line 47.

The gas or CO₂ supplied to the space 44 under pressure flows through the fluidizer ring 41, as shown by the arrows in FIG. 5, with sufficient pressure to dislodge any solid material which may have accumulated at the bottom of the metering device 32 and therefore on said fluidizer ring. The solid material dislodged from the fluidizer ring 41 by the gas flows steadily into the funnel 37 which directs it onto the screen 34 where it is dispensed in adjustable determined and accurate amounts into the mixing chamber 33 by the vibration of said screen. The solid material which is passed into the mixing chamber 33 by the screen 34 is passed into the pipeline 26 (FIG. 2) or is disposed of by any suitable means.

When the liquid in the pipeline 26 is perishable and oxygen may be detrimental to the shelf life of the product, the gas or CO₂ is utilized as the fluidizer and provides an additional gas barrier in the mixing chamber 33. The gas barrier insures that the dispensing of solid material, the mixing of the solid material with the liquid and the injection or passing of the material into the pipeline are completed in the complete exclusion of air. The solid material or infusorial earth is subjected to gas washing and it replaces the lighter air upward little by little to the brim of the feeder or supply tank.

The combination fluidizer and vibratory assembly provides a considerably saving in space because it avoids the need for shaping the hopper 31. The apparatus functions with accuracy, uniformity, reliability and economy and operates effectively with any type of free-flowing or nonfree-flowing solid material; the screen being varied in accordance with the material.

In an operating embodiment of the apparatus of the present invention, at the same adjustment of the motor 38 and during the same period of time, a screen 34 of four by four mesh delivered from 6 to 900 ounces of material per hour and a screen of six by six mesh delivered from 15 to 590 ounces of material per hour.

The motor or vibrator 38 of FIG. 2 may be controlled in speed or frequency of vibration by any suitable means such as, for example, a variable resistor connected in its input and housed in a control box 51 mounted on the outside of the hopper 31. The variable resistor connected in the motor input has a manually adjustable dial member 52 which is available outside the control box 51.

In FIG. 6, the apparatus is supported by a plurality of support members 53, 54, and others (not shown). The embodiment of FIG. 6 is especially adapted for industrial use. In the embodiment of FIG. 6, a plurality of fluidizer rings 41a, 41b, 41c and 41d, in coaxial stepped or incremental positions relative to each other, are utilized in the fluidizer instead of the single fluidizer ring 41 of FIG. 3. Each of the fluidizer rings 41a to 41d is the same as the fluidizer ring 41. The major diameter of the fluidizer ring 41a is essentially the same as the minor diameter of the fluidizer ring 41b, the major diameter of

the fluidizer ring 41b is essentially the same as the minor diameter of the fluidizer ring 41c, and the major diameter of the fluidizer ring 41c is essentially the same as the minor diameter of the fluidizer ring 41d.

While the invention has been described by means of a specific example and in specific embodiments, I do not wish to be limited thereto, for obvious modifications will occur to those skilled in the art without departing from the spirit and scope of the invention.

I claim:

1. Apparatus for supplying a powdered dry solid to a flowing liquid in a smooth and uninterrupted flow, comprising material supply means having an opening for supplying powdered dry solid material; even flow-rate means at the opening of said material supply means for providing dry solid material from said material supply means at an even flow-rate, said even flow-rate means comprising horizontally disposed screen means of determined mesh and vibrating means for vibrating substantially horizontally said screen means; and a mixing chamber below said even flow-rate means for supplying dry solid material passed by said screen means to said flowing liquid; said material supply means having a wall, a bottom closing said wall, an opening through said bottom for permitting passage of dry solid material and fluidizing means positioned at the bottom of the material supply means and abutting the wall of said material supply means for moving dry solid material into said opening, said fluidizing means comprising at least one substantially annular member of gas porous material of substantially frustoconical form positioned with respect to said bottom to provide a substantially enclosed space between said annular member and said bottom, and gas supply means for supplying a nonoxidizing gas to said space and through said annular member to the dry solid material adjacent said annular member.

2. Apparatus as claimed in claim 1, wherein said fluidizing means comprises a plurality of substantially annular members of gas porous material each of substantially frustoconical configuration positioned in stepped relation relative to each other and positioned to provide an area between said annular members and the bottom of said material supply means and gas supply means for supplying gas under pressure to said area.

3. Apparatus as claimed in claim 1, further comprising funnel means supported by said annular member for directing said dry solid material to the center of said screen means.

4. Apparatus as claimed in claim 1, further comprising funnel means supported by said annular member for directing said dry solid material to the center of said screen means and wherein said vibrating means comprises an arm affixed at one end to said funnel means and a motor affixed to the other end of said arm.

5. Apparatus as claimed in claim 1, wherein said gas under pressure is carbon dioxide.

55

60

65

70

75