

Witnesses:
 P. F. Nagle.
 H. G. Dieterich

By

Inventor
 Thomas Curr, Jr.
 Diederheim & Fairbank
 Attorneys.

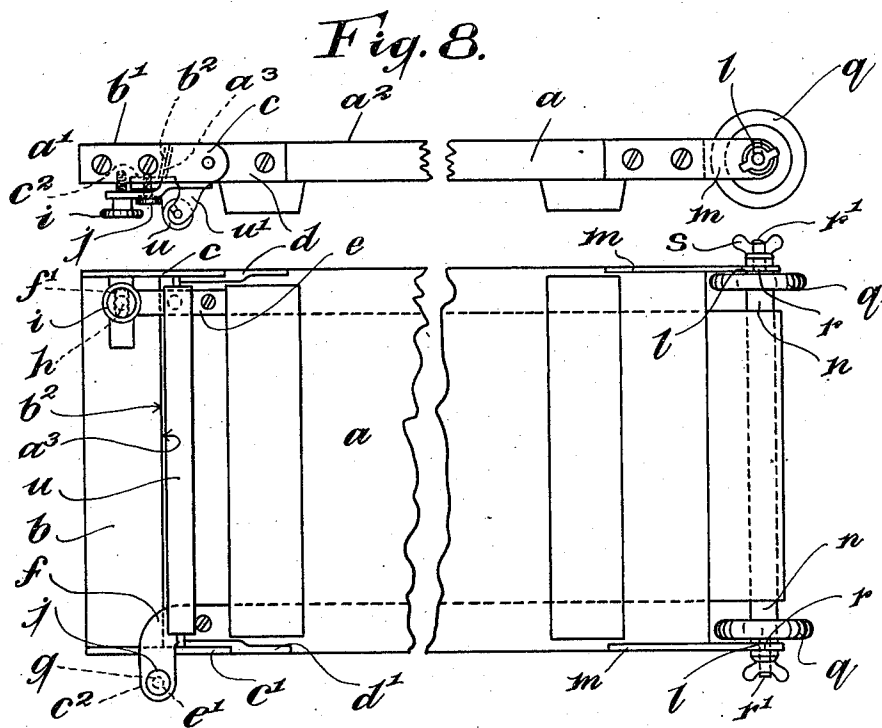

Fig. 9.

Witnesses:
 P. F. Nagel.
 L. Douville.

Inventor:
 Thomas Curr, Jr.
 By Wiederheim & Fairbanks.
 Attorneys

UNITED STATES PATENT OFFICE.

THOMAS CURR, JR., OF AIRDRIE, SCOTLAND, ASSIGNOR OF ONE-HALF TO JOHN MACLEAN, OF AIRDRIE, SCOTLAND.

DRAWING-BOARD, PRINTING-FRAME, AND THE LIKE.

996,909.

Specification of Letters Patent.

Patented July 4, 1911.

Application filed August 27, 1909. Serial No. 514,871.

To all whom it may concern:

Be it known that I, THOMAS CURR, JR., a subject of the King of Great Britain, residing at Airdrie, Lanarkshire, Scotland, have invented certain new and useful Improvements in Drawing-Boards, Printing-Frames, and the Like, of which the following is a specification.

This invention relates to an improved drawing-board in which the use of drawing pins or paste for securing the paper, tracing-cloth, or other drawing material to the board is dispensed with; my invention being equally applicable to printing frames, sketching boards, or the like. Under this invention hinged clamping means are provided at one side of the drawing-board whereby one end of the paper or other material may be secured and a roller or rollers is, or are, provided at the opposite side of the board upon which the paper or other material may be wound, and whereby it may be stretched upon the board.

In carrying out my invention with regard to drawing-boards I provide at one side of the drawing-board a piece of wood or other material which is adapted to fit close up to the edge of the drawing-board and to have its top surface flush therewith. The side piece is preferably secured to the board by means of strips of wood or metal upon the top and bottom edges to which it is hinged. The hinges may be of any convenient form, and the adjacent edges of the drawing-board and side piece may be covered with sand paper or otherwise roughened in order to obtain a better grip upon the drawing material. At the opposite side of the drawing-board and carried in slotted bearings in extensions of the top and bottom strips I provide one or more rollers upon which the drawing material may be wound, and whereby it may be stretched upon the drawing-board. Each roller is split diametrically and for the greater part of its length, one half having quadrant-shaped projections adapted to fit into corresponding recesses in the other half and the end of the paper being secured between the two halves before the latter are fitted together. The two halves of the roller may be further secured together, if desired, by means of a slidable pin or in any other convenient manner, and each roller is provided with a milled end or ends whereby the roll-

ers may be rotated. A screw and wing-nut or other clamping means is also provided upon the spindle at one end of each roller whereby the roller may be tightened in its bearings and prevented from rotation after the paper has been stretched upon the board. The outer edge of the side piece is formed perfectly true and square for use with the ordinary tee-square and is adapted to form the left-hand edge of the drawing-board. The hinges being formed flush with the face of the board no obstruction is offered to the tee-square and a perfectly true surface is obtained.

In order that my invention may be clearly understood I have hereunto appended explanatory drawings whereon I have shown my invention as applied to drawing boards and printing frames.

On the drawings:—Figure 1 is a side elevation of a drawing-board as made under my invention. Fig. 2 is an inverted plan view of Fig. 1. Figs. 3, 4 and 5 are detail views of one of the rollers, Fig. 3 being a side view of one of the interlocking parts of the roller and Fig. 4 being a side view of the other interlocking part. Fig. 5 is a cross-section on the line X—X of Fig. 3. Fig. 6 is a side elevation of a printing frame as made under my invention. Fig. 7 is an inverted plan view of Fig. 6. Fig. 8 is a side elevation of a modification of Fig. 1, and Fig. 9 is an inverted plan view of Fig. 8.

On the drawing the same reference letters wherever repeated indicate the same or similar parts.

The drawing-board *a* is provided at one end *a*¹ with clamping means which consists of a piece of wood or other material *b* adapted to fit close up to the edge of the board *a* and to have its top surface *b*¹ flush with the top surface *a*² of the board *a*. The edge *a*³ of the board *a* is beveled and the edge *b*² of the clamping piece *b* is correspondingly beveled these edges *a*³ and *b*² being covered with sand paper or otherwise roughened.

The clamping piece *b* is secured to the board *a* by means of metal or other strips *c* and *c*¹ upon the top and bottom edges respectively. These strips *c* and *c*¹ are hinged to strips *d* and *d*¹ secured to the top and bottom edges of the board and projecting strips *e* and *f* are provided on the underside of the

board and made with a screwed hole e^1 and a hole or slot f^1 the screwed hole e^1 being immediately underneath a correspondingly screwed hole g provided in a projecting part c^2 of the strip c^1 the slot f^1 being immediately underneath a screwed hole h provided in the underside of the clamping piece b , the arrangement being such that the edge b^2 of the clamping piece b can by means of screw studs i and j be pulled hard over against the edge a^3 of the board a and the paper or other material firmly and securely gripped therebetween. The screw studs i and j will retain the clamping piece b hard against the edge of the board until it is desired to release the paper or other material. When it is desired to do this the screw studs i and j are withdrawn and the clamping piece swung up on its hinges so that the edges a^3 and b^2 are moved apart and the paper or other material thereby released.

Beneath the board a and in proximity to the beveled edges a roller u may be fitted, this roller being carried in slotted bearings w^1 , and at the opposite side of the drawing-board a and carried in slotted bearings l in metal or other extension strips m is a roller n upon which the drawing paper or other material may be wound and from which it is unwound on to and stretched upon the board the paper being wound at the other side of the board upon the roller u . If desired there may be two or other number of rollers n so that in addition to carrying a roll of paper a roll of tracing cloth or tracing paper or both might also be provided for. One additional roller n is shown in Figs. 1 and 2. Each of the rollers n and u is split diametrically for the greater part of its length one half n^1 having quadrant-shaped projections n^3 adapted to fit into recesses n^4 in the other half n^2 as shown in Figs 3 and 4 and the paper or other material secured between the two halves. The two halves n^1 and n^2 of the roller n when fitted together are secured together by means of a slidable pin o in the half n^1 which is adapted to slide into a slot or groove p in the half n^2 . Each roller is provided with means whereby it may be rotated and while I have shown notched wheels q in the drawings for this purpose it is to be understood that I may employ other means. Screwed parts r^1 are provided at one or both ends of the roller spindle r and a wing nut s or other clamping means is provided by means of which the roller may be secured from turning.

In Figs. 6 and 7 I have shown my invention in one embodiment as adapted for printing frames. The means for carrying, stretching and securing the paper or other material are practically identical with the means provided for drawing-boards and it is not necessary to again describe the same.

The printing frame is preferably provided with a glass sheet t against which by means of the well known spring and bar arrangement the negative and the sensitized material to be printed on and which is being fed from the rollers n , is pressed so that it may be printed and then cut off or passed to another roller u which may be provided underneath the frame.

The arrangement for either drawing-boards or printing frames is a great improvement on the present methods of securing paper or other material on or in the same and besides, in the case of drawing-boards owing to the complete absence of pin holes the invention greatly increases the life of the board the further advantage being obtained of a great saving in the draftsman's time.

Having now fully described my invention what I claim and desire to secure by Letters Patent is:—

1. A drawing or printing board or frame comprising, in combination, a board or frame having a beveled edge at one end thereof, a strip having a correspondingly beveled edge and hinged at said end of the board or frame to the lateral edges thereof, a roller mounted at the other end of said board or frame, and means for bringing said beveled edges together, said means comprising two projections on the underside of said board or frame, a lug on said strip, a screwed stud passing through one of said projections and through said lug and a second screwed stud passing through the other of said projections and screwing into said strip.

2. A drawing or printing board or frame comprising, in combination, a board or frame having a beveled edge at one end thereof, a strip having a correspondingly beveled edge and hinged at said end of the board or frame to the lateral edges thereof, a roller mounted beneath the board or frame and in proximity to said beveled edges, rollers mounted at the other end of said board or frame, and means for bringing said beveled edges together, said means comprising two projections on the underside of said board or frame, a lug on said strip, a screwed stud passing through one of said projections and through said lug and a second screwed stud passing through the other of said projections and screwing into said strip.

3. A drawing or printing board or frame comprising, in combination, a board or frame having a beveled edge at one end thereof, a strip having a correspondingly beveled edge and hinged at said end of the board or frame to the lateral edges thereof, means for bringing said beveled edges together, slotted bearings at the other end of said board or frame, rollers removably fitted in the slotted bearings, said rollers being di-

ametricaly split, and one half of each roller having quadrant-shaped projections adapted to fit into corresponding recesses in the other half.

5 4. A drawing or printing board or frame comprising, in combination, a board or frame having a beveled edge at one end thereof, a strip having a correspondingly beveled edge and hinged at said end of the
10 board or frame to the lateral edges thereof, means for bringing said beveled edges together, slotted bearings at the other end of said board or frame, rollers removably fitted in the slotted bearings, screwed outer ends
15 on said rollers and nuts thereon for clamping said rollers in position, said rollers being diametrically split and one half of each roller having quadrant-shaped projections adapted to fit into corresponding recesses in
20 the other half.

5. The combination, with a drawing or printing board or frame having a central opening therein and a beveled edge at one end thereof, of a strip having a correspondingly beveled edge and hinged at said end of the board or frame to the lateral edges thereof, means for bringing said beveled edges together, a roller mounted beneath the board or frame and in proximity to said beveled edges, rollers mounted at the other end of
25 said board or frame, a sheet of glass over said central opening, and spring means removably secured to the board and adapted to press against the glass.
30

In testimony whereof I affix my signature
35 in presence of two witnesses.

THOMAS CURR, Jr.

Witnesses:

H. D. FITZPATRICK,
GEO. WOLFE BRUCE.

Copies of this patent may be obtained for five cents each, by addressing the "Commissioner of Patents, Washington, D. C."