

W. Reagan,

Caster.

NO. 104,201.

Patented June 14, 1870.

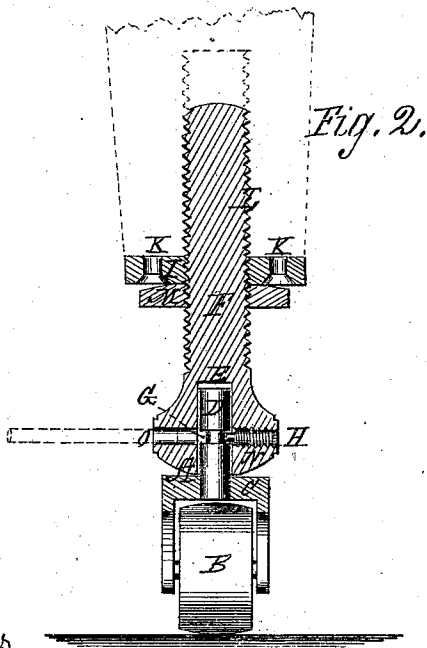
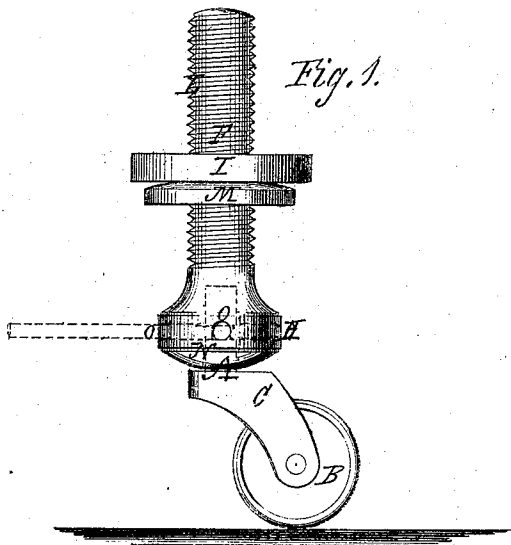

Witnesses
Arthur Child
Emile Moly.

Inventor
William Reagan

United States Patent Office.

WILLIAM REAGAN, OF NEW YORK, N. Y.

Letters Patent No. 104,201, dated June 14, 1870.

IMPROVEMENT IN CASTERS FOR BILLIARD-TABLES AND FURNITURE.

The Schedule referred to in these Letters Patent and making part of the same

I, WILLIAM REAGAN, of the city, county, and State of New York, have invented certain Improvements in Billiard-table and Furniture-Casters, of which the following is a specification.

The nature of my invention consists in constructing a caster for billiard-tables, piano-fortes, and other heavy pieces of furniture, in such manner that, after the billiard-table or other heavy piece of furniture is rolled on the casters to the desired location, the casters and their bearings can be detached from their sustaining-spindles, and said spindles used as the bearing-points of the feet of the billiard-table; and it further consists in not only using the said spindles as bearing-points for the billiard-table, but also in employing the said spindles as jack-screws for the purpose of setting the billiard-table or other heavy pieces of furniture level, with accuracy, by means of which I am enabled to roll off the piece of furniture to its location, set the same level, and readjust the level, in the event of sinkage of the floor in after time, whether the rollers are detached or not, as I will further explain by reference to the accompanying drawing, in which—

Figure 1 is a side elevation of the caster, and

Figure 2 a sectional elevation of same.

In the said drawing—

A indicates the caster, of which B is the roller, sustained in the frame C, and rotating within the same, in the usual manner.

D is a pivot, forming part of the frame C, and extending up into a vertical hole, E, in the spindle F.

This pivot has a recess, G, into which a set-screw,

H, extends, by means of which the roller is attached to the spindle F, and the pivot D, carrying the said roller, permitted to rotate within the spindle.

I is a face-plate, attached to the leg of the table by screws K K, and, with the said leg, forming a screw-socket for the threaded portion L of the spindle F, (see fig. 2,) and M is a jam-nut for holding the spindle in position.

The lower end N of the spindle F is globular, (see fig. 1,) and has holes O for inserting the end of a lever, when it may be desired to use the spindle F as a jack-screw for prying the table up or down, as the floor or circumstances may require, which can be done while the roller is attached to its spindle; but when it may be desired to detach the rollers from the spindles, to use said spindles as the bearing-points of the table, the set-screws are withdrawn, the rollers permitted to drop out, and the spindles employed as jack-screws to support and level the table, as explained.

What I claim is—

The roller B C, pivot D G, set-screw H, spindle F N O, face-plate I, and jam-nut M, all arranged and operating substantially as and for the purposes described and set forth.

In testimony whereof I have hereunto set my signature this 3d day of May, 1870.

WILLIAM REAGAN.

Witnesses:

ARTHUR NEILL,
EMILE MOLTZ.