

(No Model.)

F. L. von HIRSCH.
BOTTLE STOPPER.

No. 489,637.

Patented Jan. 10, 1893.

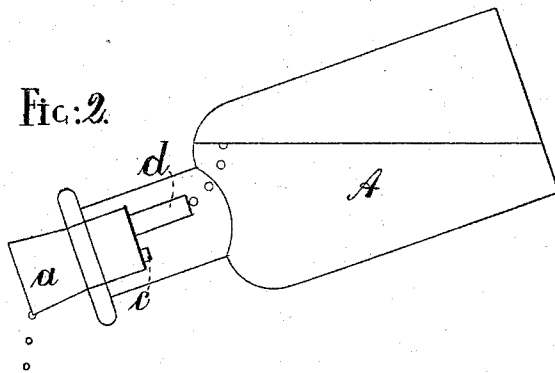
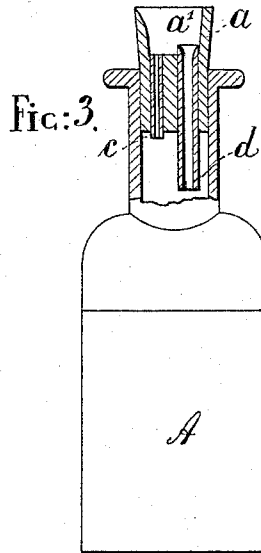
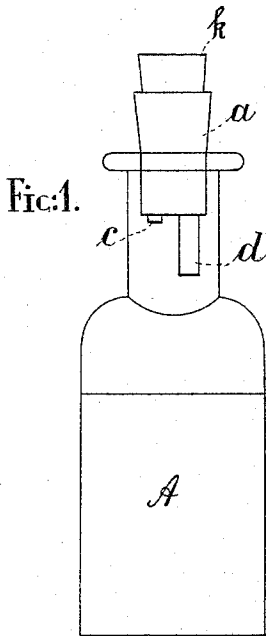

Witnesses:
Wm. Schulz.
A. Bonglmann

Inventor:
F. L. von Hirsch
by his attorneys
Roeder & Brisen

UNITED STATES PATENT OFFICE.

FRANZ LUDWIG VON HIRSCH, OF DUSSELDORF, GERMANY.

BOTTLE-STOPPER.

SPECIFICATION forming part of Letters Patent No. 489,637, dated January 10, 1893.

Application filed May 27, 1892. Serial No. 434,660. (No model.)

To all whom it may concern:

5 Be it known that I, FRANZ LUDWIG VON HIRSCH, a subject of the German Emperor, residing at Dusseldorf, in Germany, have invented certain new and useful Improvements in Bottle-Stoppers, of which the following is a specification.

10 This invention relates to a bottle-stopper which discharges the contents of the bottle in drops and is designed for medicinal, chemical or similar uses.

It consists in the various features of improvement more fully pointed out in the claim.

15 In the accompanying drawings: Figure 1 is an elevation of a bottle provided with my improved stopper. Fig. 2 a similar view showing the bottle inclined and Fig. 3 a vertical central section of Fig. 1, without the plug *k*.

20 The letter *a*, represents a bottle stopper adapted to fit into the neck of a bottle *A*, and provided on top with a mortise *a'*, for the reception of an additional stopper, cap or plug *k*. The stopper *a*, is provided with two vertical perforations through which extend two
25 tubes *c*, *d*, of unequal length, the tube *d*, pro-

jecting farther into the bottle than the tube *c*. The longer tube *d*, may also be somewhat wider than the shorter tube *c*. When the bottle is inclined (Fig. 2) a larger column of 30 liquid will press upon the shorter, than upon the longer tube. This will cause air to enter through the longer tube *d*, and liquid to be discharged through the shorter tube *c*. The diameter of this shorter tube is such, that it 35 gives off its charge in drops. The object of the stopper *k*, is to close the tubes *c*, *d*, when the bottle is put away.

What I claim is:

The combination of a bottle with a perforated stopper having mortise *a'*, a pair of 40 tubes of unequal length projecting through the stopper into the bottle and with a plug *k*, adapted to be received by the mortise, substantially as specified. 45

In testimony whereof I have signed this specification in the presence of two subscribing witnesses.

FRANZ LUDWIG VON HIRSCH.

Witnesses:

HANS FRIEDRICH,

W. OTTO.